



SPECIFICATION



HSD017GPW3-90000A-PX

1.72" - 300x344 - SPI

Version: 1.0

Date: 16.12.2022

Note: This specification is subject to change without prior notice

Document Title	HSD017GPW3-90000A-PX Preliminary specification	Page No.	1/25
Document No.		Revision	1.0

TO : Data Modul

Date :

HannStar Product Specification (Preliminary)

1.72” Transflective TFT-LCD Module **Model: HSD017GPW3-90000A-PX**

Note: (1) The information contained herein is tentative and may be changed without prior notices.

(2) Please contact HannStar Display Corp. before designing your product based on this module specification.

(3) The information contained herein is presented merely to indicate the characteristics and performance of our products. No responsibility is assumed by HannStar for any intellectual property claims or other problems that may result from application based on the module described herein.

Document Title	HSD017GPW3-90000A-PX Preliminary specification	Page No.	2/25
Document No.		Revision	1.0

Record of Revisions

Rev.	Date	Sub-Model	Description of change
1.0	2022/12/16	90000A-PX	Preliminary Product Specification was first released

Document Title	HSD017GPW3-90000A-PX Preliminary specification	Page No.	3/25
Document No.		Revision	1.0

Contents

1.0	GENERAL DESCRIPTION	4
2.0	ABSOLUTE MAXIMUM RATINGS	5
3.0	OPTICAL CHARACTERISTICS	6
4.0	BLOCK DIAGRAM	9
5.0	INTERFACE PIN CONNECTION	11
6.0	ELECTRICAL CHARACTERISTICS	13
7.0	RELIABILTY TEST ITEMS	20
8.0	OUTLINE DIMENSION	21
9.0	LOT MARK	18
10.0	PACKAGE SPECIFICATION	19
11.0	GENERAL PRECAUTION	24

Document Title	HSD017GPW3-90000A-PX Preliminary specification	Page No.	4/25
Document No.		Revision	1.0

1.0 GENERAL DESCRIPTION

1.1 Introduction

HannStar Display model HSD017NPW3-90000A-PX is a color active matrix thin film transistor (TFT) liquid crystal display (LCD) that uses amorphous silicon TFT as a switching device. This model is transfective type TFT LCD panel, a driving circuit and a back- light system. This TFT LCD has a 1.72 inch diagonally measured active display area with 300x344 (300 horizontal by 344 vertical pixel) resolution.

1.2 Features

- 1.72 inch configuration
- 16.7M signal input.
- ROHS / Halogen Free Compliance

1.3 General information

Item		Specification	Unit
Outline Dimension(LCM)		31.50(H) x 37.22(V) x1.87(D)	mm
Display area		29.10 (H) x 32.54 (V)	mm
Number of Pixel		300 RGB (H) x 344 (V)	pixels
Pixel pitch		0.09699 (H) x 0.09699(V)	mm
Pixel arrangement		RGB Vertical Stripe	--
Display mode		Normally White	--
Display Interface		SPI/DSPI/QSPI	--
NTSC		25 (Typ.)	%
Surface treatment		HCLR	--
Weight		TBD	g
Power Consumption	Logic System (Black Pattern)	(18) (typ.)	mW
	B/L System	0.198 (Max.)	W

Document Title	HSD017GPW3-90000A-PX Preliminary specification	Page No.	5/25
Document No.		Revision	1.0

2.0 ABSOLUTE MAXIMUM RATINGS

2.1 Electrical Absolute Rating

Item	Symbol	Min.	Max.	Unit	Note
Analog Supply voltage	VCI	-0.3	3.3	V	GND=0
Digital supply voltage	VDDIO	-0.3	3.3	V	GND=0
Logic Input voltage	Vin	-0.3	VDDIO+0.5	V	GND=0

Note (1):

Permanent damage may occur to the LCD module if beyond this specification.

Functional operation should be restricted to the conditions described under normal operating conditions.

Note (2):

Ta =25±2°C

2.2 Environment Absolute Rating

Item	Symbol	Min.	Max.	Unit	Note
Operating Temperature	T _{opa}	-20	70	°C	(3),(4)
Storage Temperature	T _{stg}	-30	80	°C	(3),(4)

Note (3):

If Ta below 50°C, the maximal humidity is 90%RH, if Ta over 50°C, absolute humidity should be less than 60%RH.

Note (4):

The response time will be extremely slow when the operating temperature is around -10°C, and the back ground will become darker at high temperature operating.

Document Title	HSD017GPW3-90000A-PX Preliminary specification	Page No.	6/25
Document No.		Revision	1.0

3.0 OPTICAL CHARACTERISTICS

3.1 Optical Specification (Light source : off, with D65 light)

Item	Symbol	Condition	Min.	Typ.	Max.	Unit	Note	
White Reflectance	Rw (%)	$\Theta=0$ Normal viewing angle	—	(10.84)	—	%	(4)	
Contrast Ratio	CR		—	(15)	—	—	(1)(2)	
Color Gamut	S(%)		—	(25)	—	%		
White chromaticity (CIE1931)	Wx		—	(0.305)	—			
	Wy		—	(0.374)	—			
Response Time	ms	—	(5)	—		(1)(3)		
Viewing Angle	Hor.	Θ_L	CR>2	—	(60)	—	—	(4)
		Θ_R		—	(60)	—		
	Ver.	Θ_U		—	(60)	—		
		Θ_D		—	(60)	—		

3.2 Optical Specification (Light source : on, with HSD BL)

Item	Symbol	Condition	Min.	Typ.	Max.	Unit	Note	
White luminance	Y_L	$\Theta=0$ Normal viewing angle	20	—	—	cd/m ²	(1)(4)	
Contrast Ratio	CR		—	(25)	—	—	(1)(2)	
Color Gamut	S(%)		—	(8.7)	—	%		
White chromaticity (CIE1931)	Wx		—	(0.322)				
	Wy		—	(0.358)				
Response Time	ms		6	8				
Viewing Angle	Hor.	Θ_L	CR>2	—	(60)	—	—	(1)(4)
		Θ_R		—	(60)	—		
	Ver.	Θ_U		—	(30)	—		
		Θ_D		—	(30)	—		
Brightness uniformity	BUNI	$\Theta=0$	(80)	—	—	%	(5)	
Optima View Direction			7H				(1)	

Document Title	HSD017GPW3-90000A-PX Preliminary specification	Page No.	7/25
Document No.		Revision	1.0

3.3 Measuring Condition

- Measuring surrounding : dark room
- Ambient temperature : $25 \pm 2^\circ\text{C}$
- 15min. warm-up time.

3.4 Measuring Equipment

- DMS (DMS = Display Measurement System) of AUTRONIC-MELCHERS GmbH, motorized goniometer system for comprehensive display characterization

Note (1) Definition of Viewing Angle:

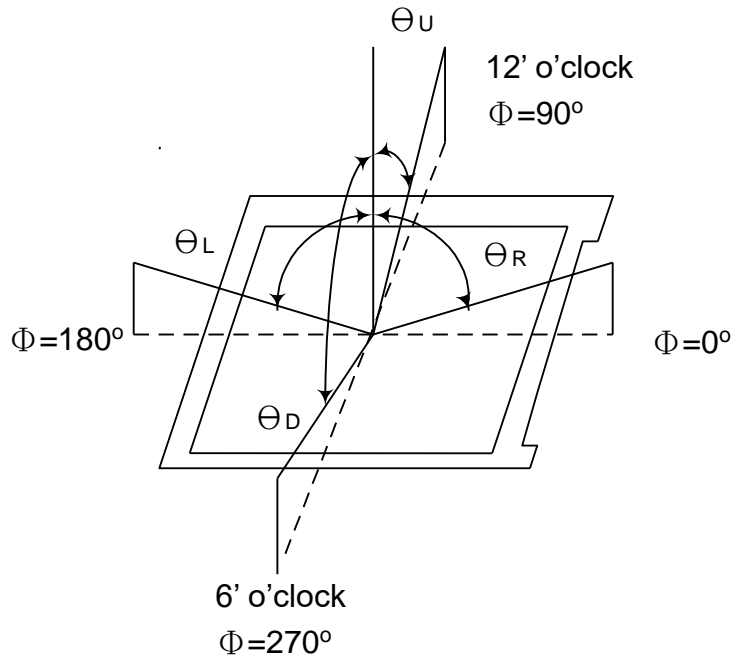

Note (2) Definition of Contrast Ratio (CR) :

measured at the center point of panel

$$\text{CR} = \frac{\text{Luminance with all pixels white}}{\text{Luminance with all pixels black}}$$

Document Title	HSD017GPW3-90000A-PX Preliminary specification	Page No.	8/25
Document No.		Revision	1.0

Note (3) Definition of Response Time : Sum of Tr and Tf

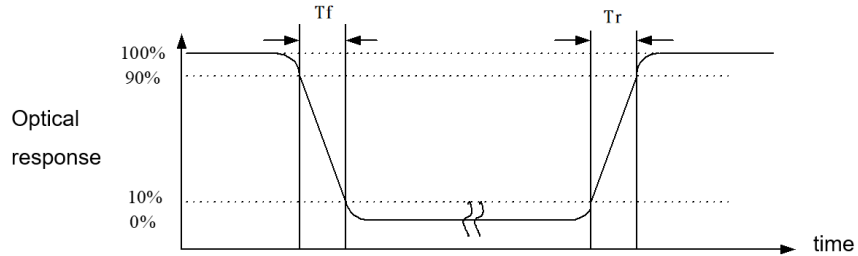

Note (4) Definition of optical measurement setup

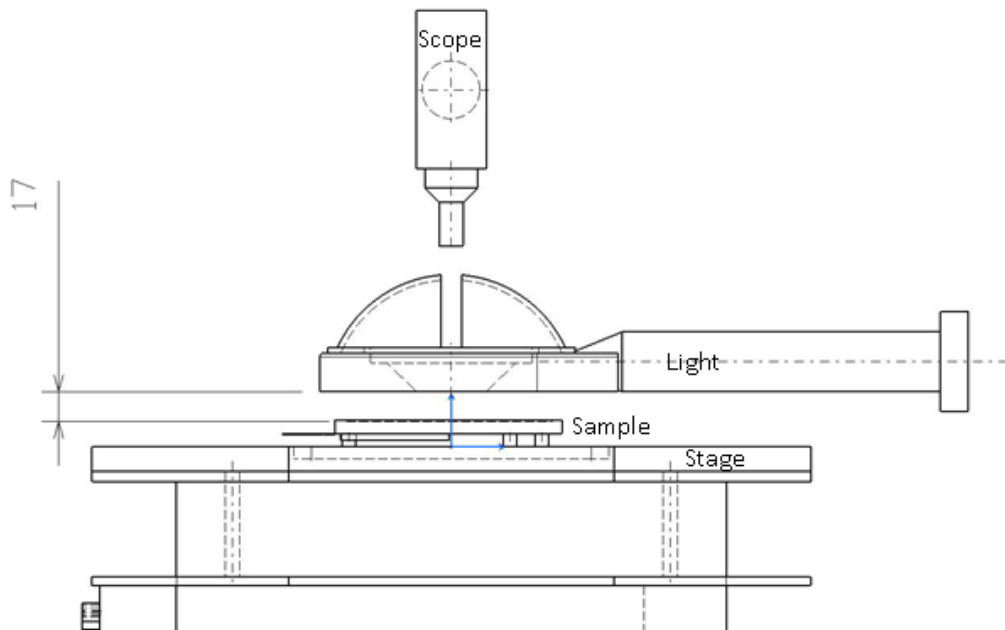

Document Title	HSD017GPW3-90000A-PX Preliminary specification	Page No.	9/25
Document No.		Revision	1.0

Note (5) Definition of brightness uniformity

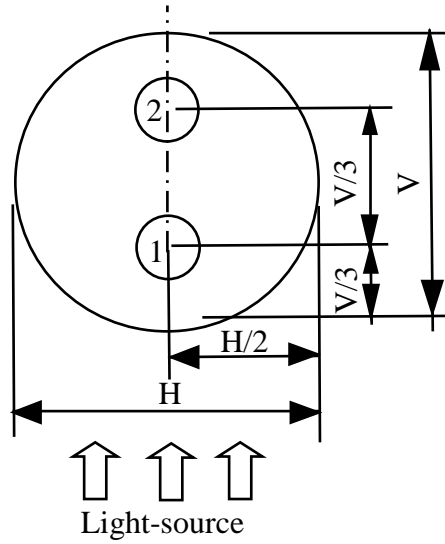

$$\text{Luminance uniformity} = \frac{(\text{Min Luminance of 2 points})}{(\text{Max Luminance of 2 points})} \times 100\%$$

4.0 BLOCK DIAGRAM

4.1 TFT LCD Module

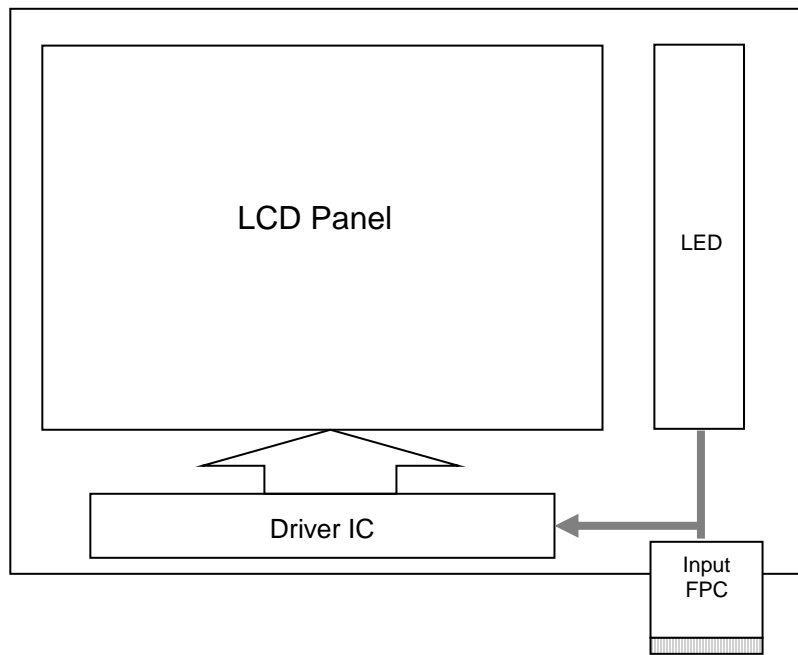

Document Title	HSD017GPW3-90000A-PX Preliminary specification	Page No.	10/25
Document No.		Revision	1.0

4.2 Pixel Format

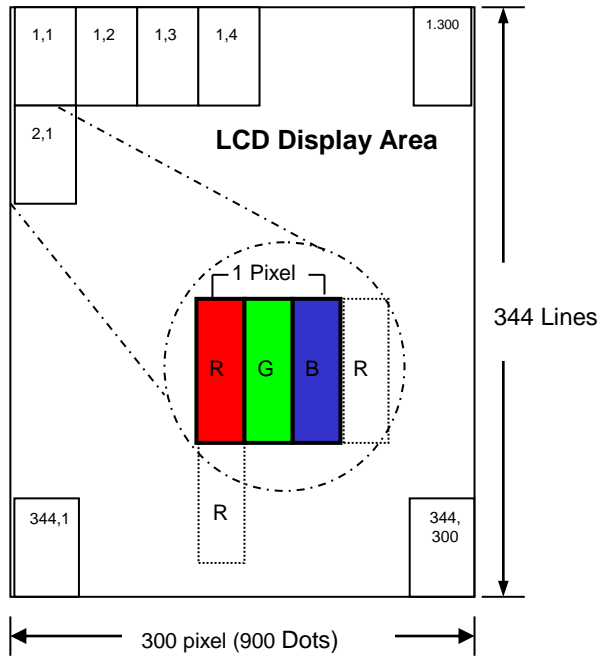

4.3 Display Direction



Display Scanning Direction

Document Title	HSD017GPW3-90000A-PX Preliminary specification	Page No.	11/25
Document No.		Revision	1.0

5.0 INTERFACE PIN CONNECTION

5.1 LCM Pin Assignment

NO.	Symbol	Description
1	GND	Ground
2	LEDK	LED Cathode
3	LEDA	LED Anode
4	VCI	Power Supply
5	VDDIO	Power Supply
6	RESET	System reset pin
7	IM1	Interface selection
8	TE	Frame head pulse signal. Utilize this signal when synchronizing RAM data write operations.
9	CSX	SPI chip selection pin
10	DCX	SPI Data/command Select(4wire SPI interface)
11	SCL	SPI clock signal
12	SDA	SPI data signal
13	D0	SPI data signal
14	D1	SPI data signal
15	D2	SPI data signal
16	GND	Ground

Note :

(1) Interface selection

IM1	Interface	Used pins
0	4-wire SPI (0xE4=0)	CSX, DCX, SCL, SDA
0	4-wire DSPI (0xE4=1)	CSX, DCX, SCL, SDA, D[0]
1	3-wire SPI	CSX, DCX=GND, SCL, SDA
1	QSPI	CSX, DCX=VDDIO, SCL, SDA, D[0:2]

Document Title	HSD017GPW3-90000A-PX Preliminary specification	Page No.	12/25
Document No.		Revision	1.0

5.2 Relationship Between Displayed Color and Input

	Display	MSB								LSB								Gray scale Level									
		R7	R6	R5	R4	R3	R2	R1	R0	G7	G6	G5	G4	G3	G2	G1	G0		B7	B6	B5	B4	B3	B2	B1	B0	
Basic color	Black	L	L	L	L	L	L	L	L	L	L	L	L	L	L	L	L	L	L	L	L	L	L	L	L	-	
	Blue	L	L	L	L	L	L	L	L	L	L	L	L	L	L	L	L	H	H	H	H	H	H	H	H	-	
	Green	L	L	L	L	L	L	L	L	H	H	H	H	H	H	H	H	L	L	L	L	L	L	L	L	-	
	Light Blue	L	L	L	L	L	L	L	L	H	H	H	H	H	H	H	H	H	H	H	H	H	H	H	H	-	
	Red	H	H	H	H	H	H	H	H	L	L	L	L	L	L	L	L	L	L	L	L	L	L	L	L	-	
	Purple	H	H	H	H	H	H	H	H	L	L	L	L	L	L	L	L	H	H	H	H	H	H	H	H	-	
	Yellow	H	H	H	H	H	H	H	H	H	H	H	H	H	H	H	H	L	L	L	L	L	L	L	L	-	
White	H	H	H	H	H	H	H	H	H	H	H	H	H	H	H	H	H	H	H	H	H	H	H	H	-		
Gray scale of Red	Black	L	L	L	L	L	L	L	L	L	L	L	L	L	L	L	L	L	L	L	L	L	L	L	L	L0	
	Dark ↑ ↓ Light	L	L	L	L	L	L	L	H	L	L	L	L	L	L	L	L	L	L	L	L	L	L	L	L	L1	
		L	L	L	L	L	L	H	L	L	L	L	L	L	L	L	L	L	L	L	L	L	L	L	L	L2	
		:	:	:	:	:	:	:	:	:	:	:	:	:	:	:	:	:	:	:	:	:	:	:	:	L3...L251	
		H	H	H	H	H	H	L	L	L	L	L	L	L	L	L	L	L	L	L	L	L	L	L	L	L252	
	H	H	H	H	H	H	L	H	L	L	L	L	L	L	L	L	L	L	L	L	L	L	L	L	L253		
	H	H	H	H	H	H	H	L	L	L	L	L	L	L	L	L	L	L	L	L	L	L	L	L	L254		
Red	H	H	H	H	H	H	H	L	L	L	L	L	L	L	L	L	L	L	L	L	L	L	L	Red L255			
Gray scale of Green	Black	L	L	L	L	L	L	L	L	L	L	L	L	L	L	L	L	L	L	L	L	L	L	L	L	L0	
	Dark ↑ ↓ Light	L	L	L	L	L	L	L	L	L	L	L	L	L	L	H	L	L	L	L	L	L	L	L	L1		
		L	L	L	L	L	L	L	L	L	L	L	L	L	L	H	L	L	L	L	L	L	L	L	L2		
		:	:	:	:	:	:	:	:	:	:	:	:	:	:	:	:	:	:	:	:	:	:	:	L3...L251		
		L	L	L	L	L	L	L	L	H	H	H	H	H	L	L	L	L	L	L	L	L	L	L	L252		
	L	L	L	L	L	L	L	L	H	H	H	H	H	L	H	L	L	L	L	L	L	L	L	L253			
	L	L	L	L	L	L	L	L	H	H	H	H	H	H	L	L	L	L	L	L	L	L	L	L254			
Green	L	L	L	L	L	L	L	H	H	H	H	H	H	H	L	L	L	L	L	L	L	L	Green L255				
Gray scale of Blue	Black	L	L	L	L	L	L	L	L	L	L	L	L	L	L	L	L	L	L	L	L	L	L	L	L	L0	
	Dark ↑ ↓ Light	L	L	L	L	L	L	L	L	L	L	L	L	L	L	L	H	L	L	L	L	L	L	L	H	L1	
		L	L	L	L	L	L	L	L	L	L	L	L	L	L	L	L	L	L	L	L	L	L	L	H	L2	
		:	:	:	:	:	:	:	:	:	:	:	:	:	:	:	:	:	:	:	:	:	:	:	L3...L251		
		L	L	L	L	L	L	L	L	L	L	L	L	L	L	L	H	H	H	H	H	L	L	L	L252		
	L	L	L	L	L	L	L	L	L	L	L	L	L	L	L	H	H	H	H	H	L	H	L	L253			
	L	L	L	L	L	L	L	L	L	L	L	L	L	L	L	H	H	H	H	H	H	L	L	L254			
Blue	L	L	L	L	L	L	L	L	L	L	L	L	L	L	H	H	H	H	H	H	H	H	Blue L255				
Gray scale of White & Black	Black	L	L	L	L	L	L	L	L	L	L	L	L	L	L	L	L	L	L	L	L	L	L	L	L	L0	
	Dark ↑ ↓ Light	L	L	L	L	L	L	H	L	L	L	L	L	H	L	L	L	L	L	H	L	L	L	L	L	H	L1
		L	L	L	L	L	H	L	L	L	L	L	H	L	L	L	L	L	H	L	L	L	L	L	H	L	L2
		:	:	:	:	:	:	:	:	:	:	:	:	:	:	:	:	:	:	:	:	:	:	:	:	:	L3...L251
		H	H	H	H	H	L	L	H	H	H	H	L	L	H	H	H	H	L	L	H	H	H	H	L	L	L252
	H	H	H	H	H	L	H	H	H	H	H	L	H	H	H	H	H	L	H	H	H	H	H	L	H	L253	
	H	H	H	H	H	H	L	H	H	H	H	H	L	H	H	H	H	H	L	H	H	H	H	H	L	L254	
White	H	H	H	H	H	H	H	H	H	H	H	H	H	H	H	H	H	H	H	H	H	H	H	H	H	White L255	

Document Title	HSD017GPW3-90000A-PX Preliminary specification	Page No.	13/25
Document No.		Revision	1.0

6.0 ELECTRICAL CHARACTERISTICS

6.1 TFT LCD Module

Item	Symbol	Min.	Typ.	Max.	Unit	Note
Analog Supply voltage	V _{CI}	2.5	-	3.3	V	
Analog supply current	I _{VCI}	-	TBD	-	mA	V _{CI} =2.8V
Logic supply voltage	V _{DDIO}	1.65	-	3.3	V	
Logic supply current	I _{VDDIO}	-	TBD	-	mA	V _{DDIO} =1.8V
Logic input voltage	V _{IH}	0.8*V _{DDIO}	-	V _{DDIO}	V	
	V _{IL}	GND	-	0.2*V _{DDIO}	V	

6.2 Backlight Unit

Parameter	Symbol	Min	Typ	Max	Units	Condition
LED Current	I _F	--	60	--	mA	Ta=25°C
LED Voltage	V _F	2.8	3.0	3.3	Volt	Ta=25°C
LED Life-Time	N/A	TBD	--	--	Hour	Ta=25°C Note (2)

Note (1) LED life time (Hr) can be defined as the time in which it continues to operate under the condition: Ta=25±3°C, typical IL value indicated in the above table until the brightness becomes less than 50%.

Note (2) The "LED life time" is defined as the module brightness decrease to 50% original brightness at Ta=25°C. and LED typical current. The LED lifetime could be decreased if operating I_F is larger than LED typical current. The constant current driving method is suggested.

Note (3) LED light bar circuit :

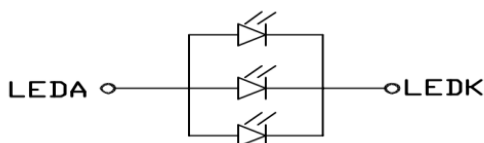

$$I_f = 60 \text{ mA}; \quad V_f = 2.8 \sim 3.3 \text{ V}$$

Document Title	HSD017GPW3-90000A-PX Preliminary specification	Page No.	14/25
Document No.		Revision	1.0

6.3 Interface Characteristics

6.3.1 4-wire SPI Timing

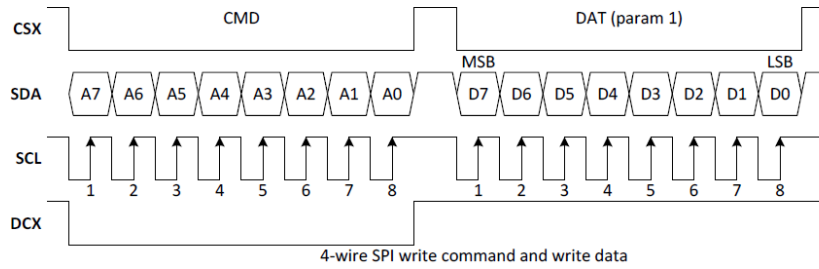

Figure 6-1: 4-wire SPI write command and write data

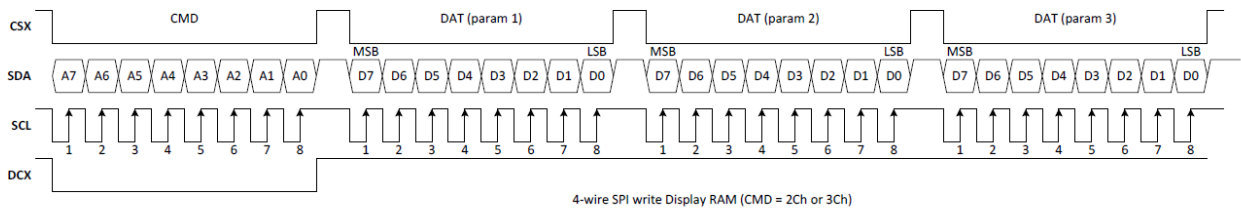

Figure 6-2: 4-wire SPI write RAM data

(Note: for each time using 0x2C or 0x3C cmd to write RAM data, please write 4 pixels data or more.)

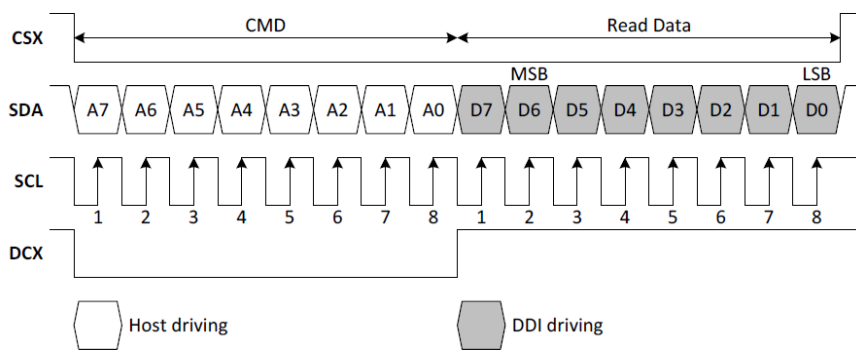

Figure 6-3: 4-wire SPI Read

Document Title	HSD017GPW3-90000A-PX Preliminary specification	Page No.	15/25
Document No.		Revision	1.0

6.3.2 4-wire DSPI Timing

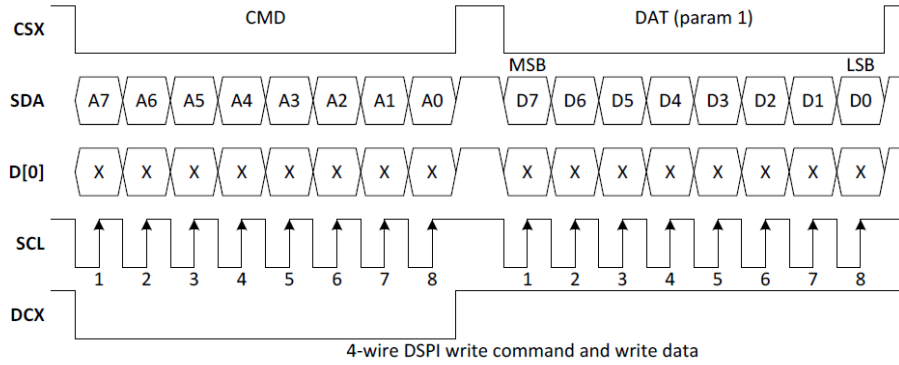

Figure 6-4: 4-wire DSPI write command and write data

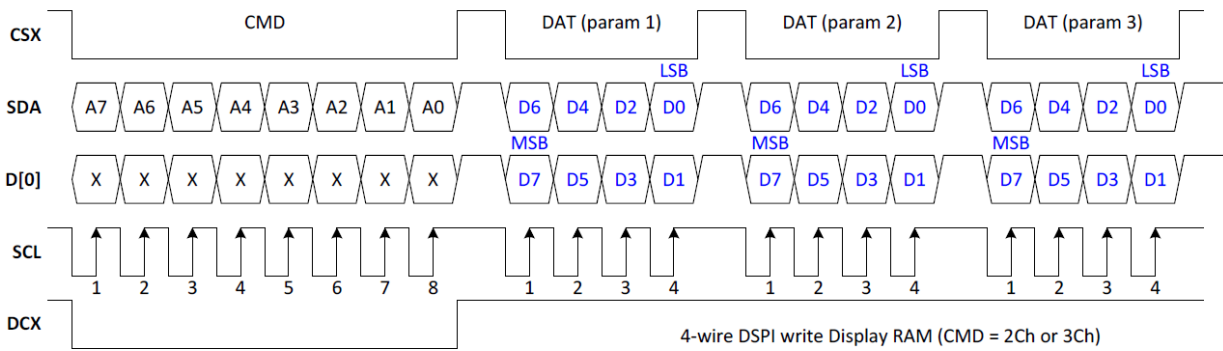

Figure 6-5: 4-wire DSPI write RAM data

(Note: for each time using 0x2C or 0x3C cmd to write RAM data, please write 4 pixels data or more.)

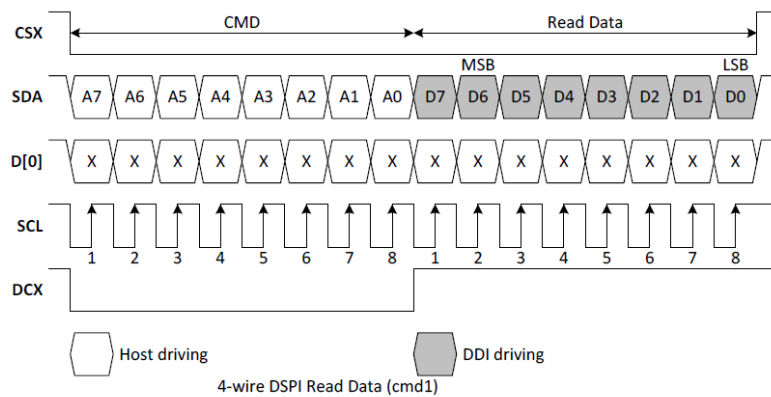

Figure 6-6: 4-wire DSPI Read

Document Title	HSD017GPW3-90000A-PX Preliminary specification	Page No.	16/25
Document No.		Revision	1.0

6.3.3 3-wire SPI Timing

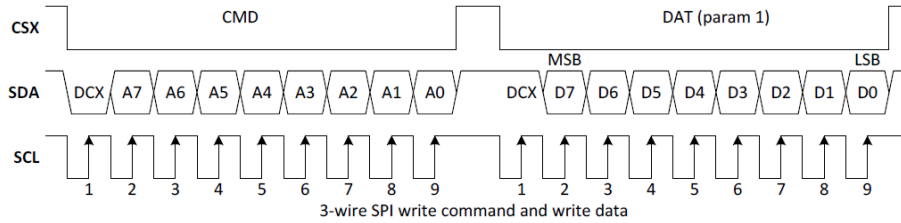

Figure 6-7: 3-wire SPI write command and write data

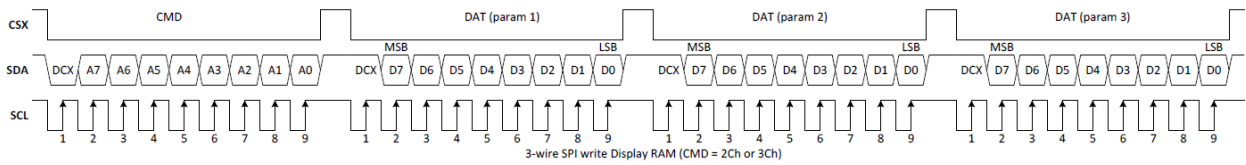

Figure 6-8: 3-wire SPI write RAM data

(Note: for each time using 0x2C or 0x3C cmd to write RAM data, please write 4 pixels data or more.)

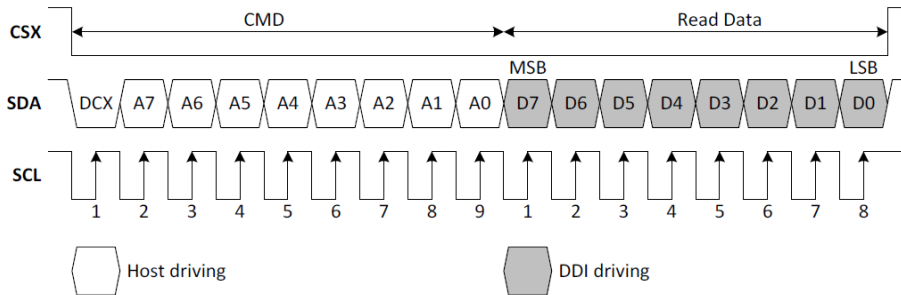

Figure 6-9: 3-wire SPI Read

Document Title	HSD017GPW3-90000A-PX Preliminary specification	Page No.	17/25
Document No.		Revision	1.0

6.3.4 3-wire QSPI Timing

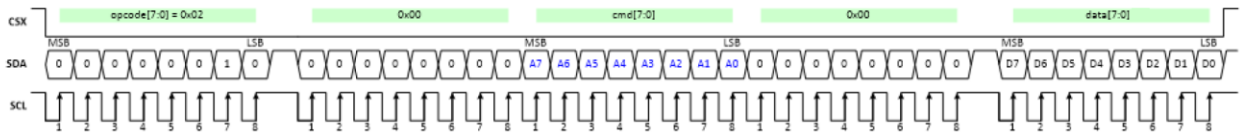

Figure 6-10: QSPI write command and write data (1 data lane)

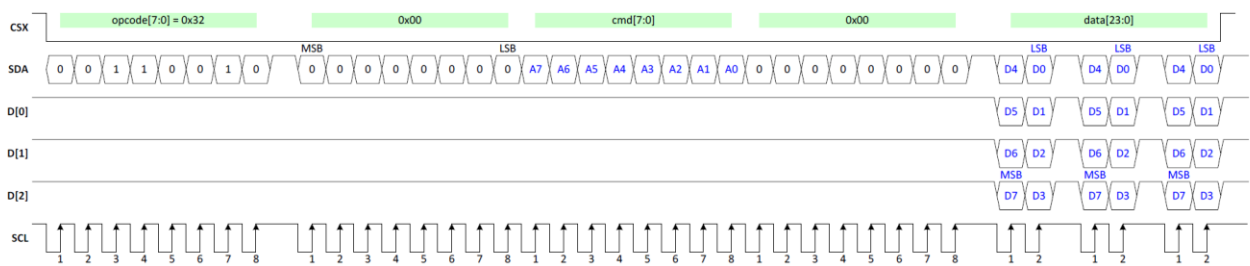

Figure 6-11: QSPI write command and write data (4 data lanes)
(Note: for each time using 0x2C or 0x3C cmd to write RAM data, please write 4 pixels data or more.)

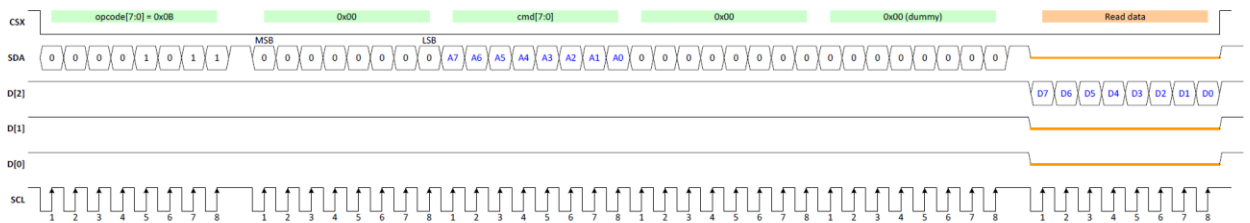
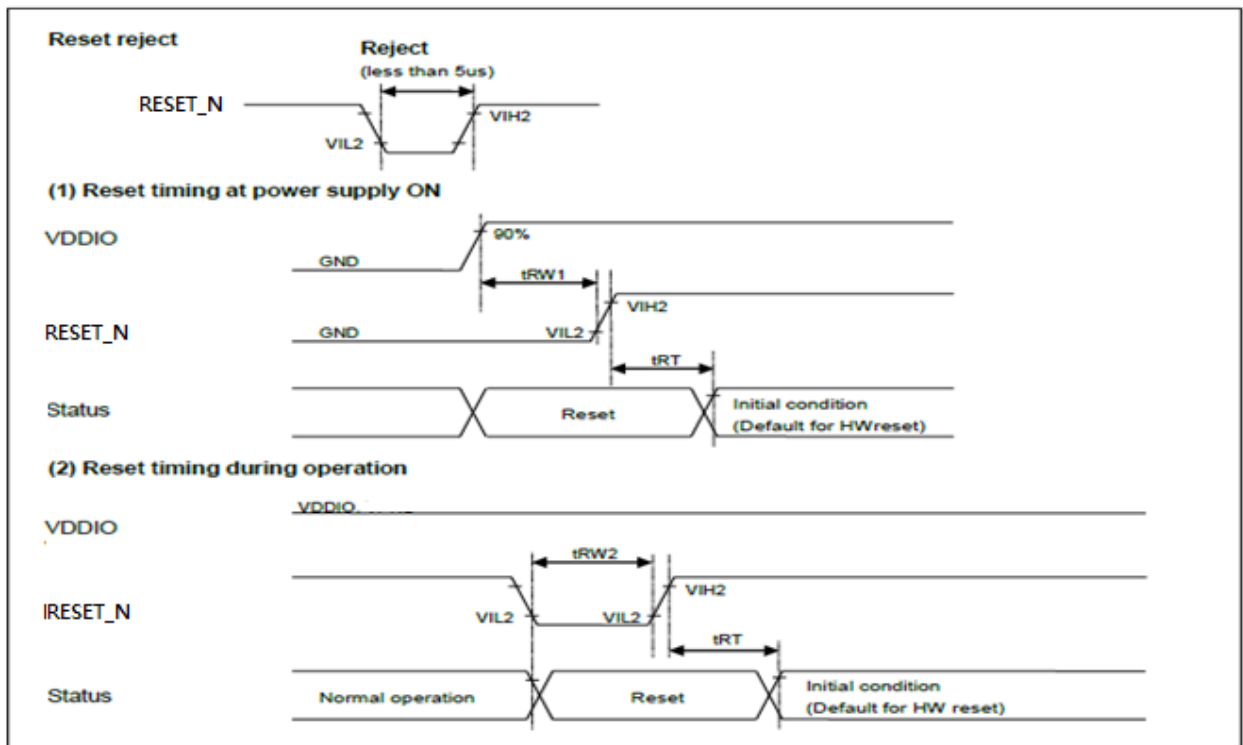

Figure 6-12: QSPI Read

Document Title	HSD017GPW3-90000A-PX Preliminary specification	Page No.	18/25
Document No.		Revision	1.0

6.4 RESET CHARACTERISTICS

Item	Symbol	Unit	Test Condition	Min.	Typ.	Max.
Reset "Low" level width 1	tRW1	ms	Power On	1	-	-
Reset "Low" level width 2	tRW2	ms	Operation	1	-	-
Reset time	tRT	ms	-	20	-	-



Document Title	HSD017GPW3-90000A-PX Preliminary specification	Page No.	19/25
Document No.		Revision	1.0

6.5 Power Sequence

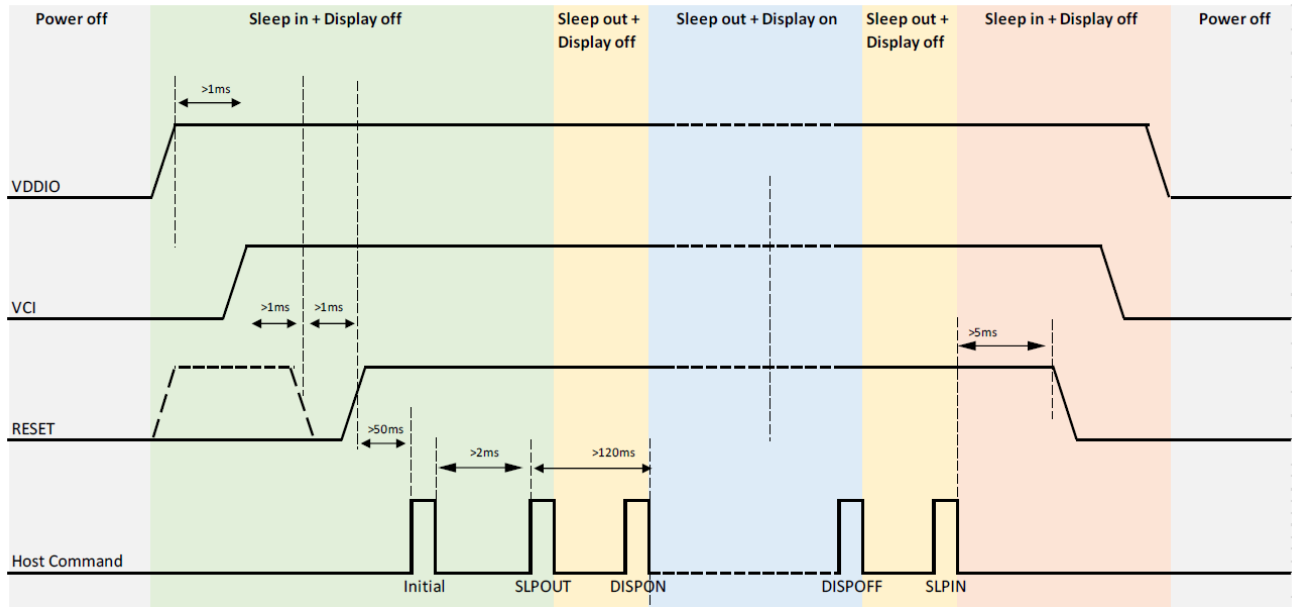

Document Title	HSD017GPW3-90000A-PX Preliminary specification	Page No.	20/25
Document No.		Revision	1.0

7.0 RELIABILITY TEST ITEMS

No.	Item	Conditions	Remark
1	High Temperature Storage	Ta=+80±2°C, 48hrs	1、2、3
2	Low Temperature Storage	Ta=-30±2°C, 48hrs	1、2、3
3	High Temperature Operation	Ta=70±2°C, 48hrs	1、2、3
4	Low Temperature Operation	Ta=-20±2°C, 48hrs	1、2、3
5	High Temperature and High Humidity (non operation)	Ta=+60oC, 90%RH, 48hrs	1、2、3
6	Thermal Cycling Test (non operation)	-20°C (30min)→+70°C (30min),20 cycles	1、2、3
7	Vibration (with carton)	Random: 0.015G ² /Hz, 5~200Hz -6dB/Octave, 200~400Hz XYZ 各方向 2hrs	
8	Drop (with carton)	Drop height condition, basis on the product weight and Follw QB100-0027 1 corner, 3 edges, 6 surfaces	

Note1: There is no display function NG issue occurred, all the cosmetic specification is judged before the reliability stress.

Note2: All of the function & cosmetic Judgment basis base on room temperature.
(The tested module must have enough recovery time at least 2 hours at room temperature.)

Note3: The test condition definition panel's surface temperature.

Document Title	HSD017GPW3-90000A-PX Preliminary specification	Page No.	21/25
Document No.		Revision	1.0

8.0 OUTLINE DIMENSION

Unit : mm

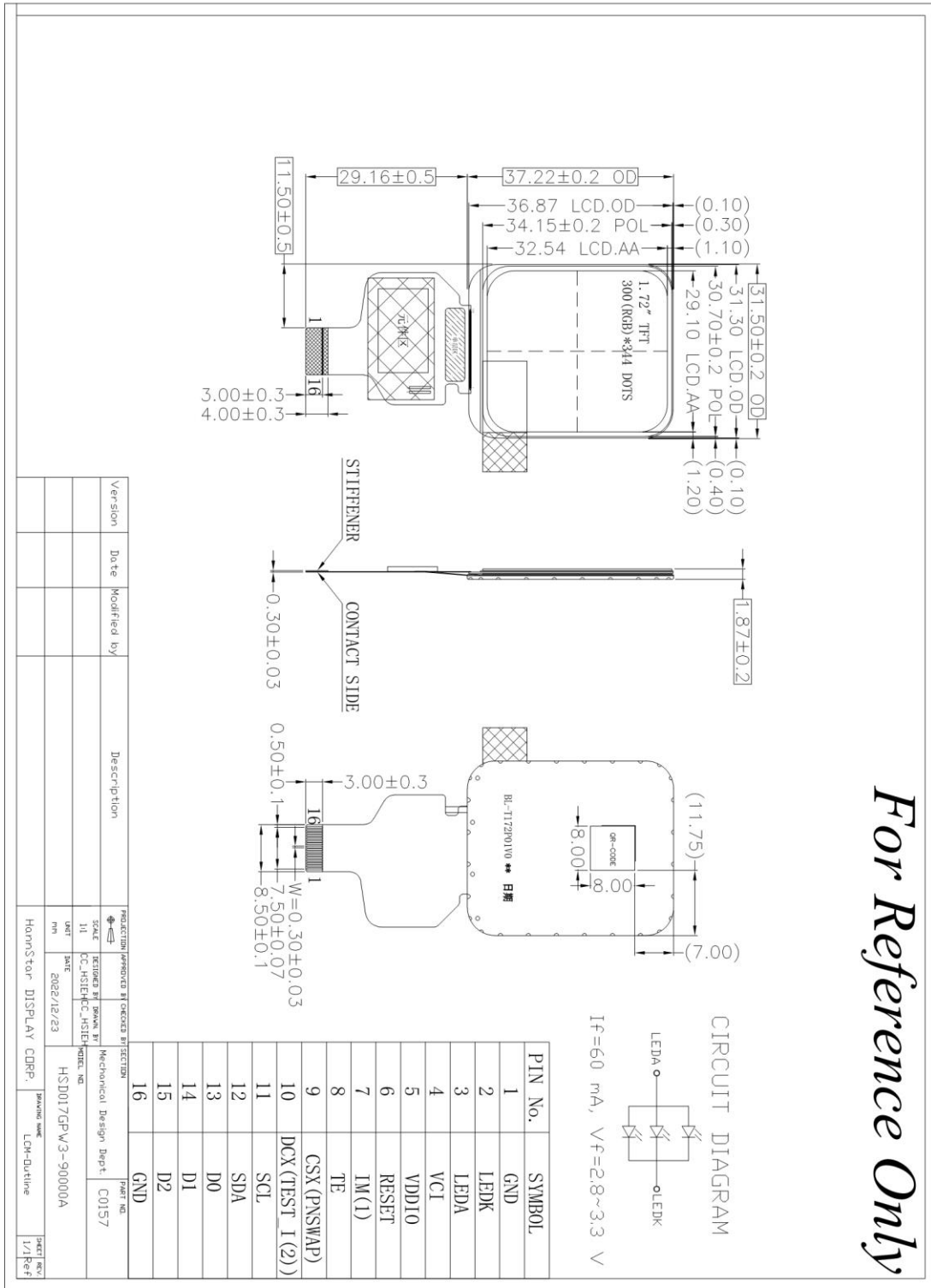

For Reference Only

Document Title	HSD017GPW3-90000A-PX Preliminary specification	Page No.	22/25
Document No.		Revision	1.0

9.0 LOT MARK

9.1 Lot Mark

1	2	3	4	5	6	7	8	9	10	11	12	13	14	15
---	---	---	---	---	---	---	---	---	----	----	----	----	----	----

Code 1,2,3,4,5,6: HannStar internal flow control code.

Code 7: production location.

Code 8: production year.

Code 9: production month.

Code 10,11,12,13,14,15: serial number.

Note (1) Production Year: Code 8 is defined by the last number of the year, for example

Year	2016	2017	2018	2019	2020	2021	2022	2023	2024	2025	2026
Mark	6	7	8	9	0	1	2	3	4	5	6

Note (2) Production Month

Month	Jan.	Feb.	Mar.	Apr.	May.	Jun.	Jul.	Aug.	Sep.	Oct	Nov.	Dec.
Mark	1	2	3	4	5	6	7	8	9	A	B	C

9.2 Detail of Lot Mark

- (1) Below label is attached on the backside of the LCD module. See Section 8.0: Outline Dimension.
- (2) The detail of Lot Mark is attached as below.
- (3) This is subject to change without prior notice.



Document Title	HSD017GPW3-90000A-PX Preliminary specification	Page No.	23/25
Document No.		Revision	1.0

10.0 PACKAGE SPECIFICATION

10.1 Packing form

TBD

10.2 Packing Drawing

TBD

Document Title	HSD017GPW3-90000A-PX Preliminary specification	Page No.	24/25
Document No.		Revision	1.0

11.0 GENERAL PRECAUTION

11.1 Use Restriction

This product is not authorized for use in life supporting systems, aircraft navigation control systems, military systems and any other application where performance failure could be life-threatening or otherwise catastrophic.

11.2 Disassembling or Modification

Do not disassemble or modify the module. It may damage sensitive parts inside LCD module, and may cause scratches or dust on the display. HannStar does not warrant the module, if customers disassemble or modify the module.

11.3 Breakage of LCD Panel

11.3.2. If LCD panel is broken and liquid crystal spills out, do not ingest or inhale liquid crystal, and do not contact liquid crystal with skin.

11.3.3. If liquid crystal contacts mouth or eyes, rinse out with water immediately.

11.3.4. If liquid crystal contacts skin or cloths, wash it off immediately with alcohol and rinse thoroughly with water.

11.3.5. Handle carefully with chips of glass that may cause injury, when the glass is broken.

11.4 Electric Shock

11.4.1. Disconnect power supply before handling LCD module.

11.4.2. Do not pull or fold the LED cable.

11.4.3. Do not touch the parts inside LCD modules and the fluorescent LED's connector or cables in order to prevent electric shock.

11.5 Absolute Maximum Ratings and Power Protection Circuit

11.5.1. Do not exceed the absolute maximum rating values, such as the supply voltage variation, input voltage variation, variation in parts' parameters, environmental temperature, etc., otherwise LCD module may be damaged.

11.5.2. Please do not leave LCD module in the environment of high humidity and high temperature for a long time.

11.5.3. It's recommended to employ protection circuit for power supply.

Document Title	HSD017GPW3-90000A-PX Preliminary specification	Page No.	25/25
Document No.		Revision	1.0

11.6 Operation

- 11.6.1 Do not touch, push or rub the polarizer with anything harder than HB pencil lead.
- 11.6.2 Use fingerstalls of soft gloves in order to keep clean display quality, when persons handle the LCD module for incoming inspection or assembly.
- 11.6.3 When the surface is dusty, please wipe gently with absorbent cotton or other soft material.
- 11.6.4 Wipe off saliva or water drops as soon as possible. If saliva or water drops contact with polarizer for a long time, they may causes deformation or color fading.
- 11.6.5 When cleaning the adhesives, please use absorbent cotton wetted with a little petroleum benzine or other adequate solvent.

11.7 Static Electricity

- 11.7.1 Protection film must remove very slowly from the surface of LCD module to prevent from electrostatic occurrence.
- 11.7.2 Because LCD module use CMOS-IC on circuit board and TFT-LCD panel, it is very weak to electrostatic discharge. Please be careful with electrostatic discharge. Persons who handle the module should be grounded through adequate methods.

11.8 Strong Light Exposure

The module shall not be exposed under strong light such as direct sunlight. Otherwise, display characteristics may be changed.

11.9 Disposal

When disposing LCD module, obey the local environmental regulations.



ALL TECHNOLOGIES. ALL COMPETENCIES. ONE SPECIALIST.



DATA MODUL AG
Landsberger Straße 322
DE-80687 Munich
Phone: +49-89-56017-0

DATA MODUL WEIKERSHEIM GMBH
Lindenstraße 8
DE-97990 Weikersheim
Phone: +49-7934-101-0



More information and worldwide locations can be found at

www.data-modul.com