



SPECIFICATION

AUO
AUO Display+

G185HAN01.4

18.5"–FHD–eDP

Version: 0.0
Date: 09.06.2022

Note: This specification is subject to change without prior notice

(V) Preliminary Specification
() Final Specification

Module	18.5" Color TFT-LCD
Model Name	G185HAN01.4

<p style="text-align: center;">Customer Date</p> <hr/> <p style="text-align: center;">Checked & Approved by</p> <hr/>	<p style="text-align: center;">Approved by Date</p> <p style="text-align: center;"><u>Flossie Chuang</u> <u>2022/06/09</u></p> <p style="text-align: center;">Prepared by</p> <p style="text-align: center;"><u>Athena Wu</u> <u>2022/06/09</u></p>
<p>General Display Business Unit/ AUO Display Plus corporation</p>	

Contents

1. Handling Precautions	4
2. General Description	5
2.1 Display Characteristics	5
2.2 Optical Characteristics.....	6
3. Functional Block Diagram	9
4. Absolute Maximum Ratings	10
4.1 TFT LCD Module.....	10
4.2 Absolute Ratings of Environment.....	10
5. Electrical characteristics.....	11
5.1 TFT LCD Module.....	11
5.1.1 Power Specification	11
5.1.2 Signal Electrical Characteristics	11
5.2 Backlight Unit	13
6. Signal Characteristic	15
6.1 Pixel Format Image.....	15
6.2 Scanning Direction	15
6.3 Signal Description.....	16
6.3.2 TFT LCD Module Pin Assignment.....	16
6.4 Interface Timing.....	19
6.4.1 Timing Characteristics	19
6.4.2 Input Timing Diagram	19
6.5 Power ON/OFF Sequence.....	20
7. Reliability Test	23
8. Shipping Label & Packaging.....	24
8.1 Shipping Label.....	24
8.2 Packaging	25
8.3 Palletizing.....	26
9. Mechanical Characteristics.....	27
10. Safety.....	29
10.1 Sharp Edge Requirements.....	29
10.2 Materials.....	29
10.2.1 Toxicity.....	29
10.2.2 Flammability.....	29
10.3 Capacitors.....	29
10.4 National Test Lab Requirement.....	29



Record of Revision

Version & Date	Page	Old description	New Description
0.0 2022/06/09			Preliminary Specification

AUO Display Plus Confidential For Data Modul Use Only

I. Handling Precautions

- 1) Since front polarizer is easily damaged, pay attention not to scratch it.
- 2) Be sure to turn off power supply when inserting or disconnecting from input connector.
- 3) Wipe off water drop immediately. Long contact with water may cause discoloration or spots.
- 4) When the panel surface is soiled, wipe it with absorbent cotton or other soft cloth.
- 5) Since the panel is made of glass, it may break or crack if dropped or bumped on hard surface.
- 6) Since CMOS LSI is used in this module, take care of static electricity and insure human earth when handling.
- 7) Do not open or modify the Module Assembly.
- 8) Do not press the reflector sheet at the back of the module to any directions.
- 9) In case if a Module has to be put back into the packing container slot after it was taken out from the container, do not press the center of LED lightbar edge. Instead, press at the far ends of the LED light bar edge softly. Otherwise the TFT Module may be damaged.
- 10) At the insertion or removal of the Signal Interface Connector, be sure not to rotate nor tilt the Interface Connector of the TFT Module.
- 11) After installation of the TFT Module into an enclosure, do not twist nor bend the TFT Module even momentarily. While designing the enclosure, it should be taken into consideration that no bending/twisting forces are applied to the TFT Module from outside. Otherwise the TFT Module may be damaged.
- 12) Small amount of materials having no flammability grade is used in the LCD module. The LCD module should be supplied by power complied with requirements of Limited Power Source (IEC60950-1 or UL60950-1), or be applied exemption.

2. General Description

This specification applies to the 18.5 inch-wide Color AHVA (IPS-like) TFT-LCD Module G185HAN01.4. The display supports the FHD [1920(H) x 1080(V)] screen format and 16.7M colors (True 8 bit). All input signals are eDP interface compatible.

2.1 Display Characteristics

The following items are characteristics summary on the table under 25°C condition:

ITEMS	Unit	SPECIFICATIONS
Screen Diagonal	[mm]	469.16(18.47")
Active Area	[mm]	408.96 (H) x 230.04 (V)
Pixels H x V		1920x1080
Pixel Pitch	[um]	213 (per one triad) x 213
Pixel Arrangement		R.G.B. Vertical Stripe
Display Mode		AHVA mode, Normally black
White Luminance (Center)	[cd/m ²]	1800 cd/m ² (Typ.)
Contrast Ratio		1000 (Typ.)
Optical Response Time	[msec]	20ms
Nominal Input Voltage VDD	[Volt]	5V (Typ)
Power Consumption (VDD line + LED line)	[Watt]	52.5W(Max)
Weight	[Grams]	1600(Typ)±10%
Physical Size	[mm]	434.9 x 259.6 x 15.17
Electrical Interface		EDP
Support Color		16.7M colors, True 8 bit
Surface Treatment		AGLR,3H
RoHS Compliance		RoHS Compliance
Temperature Range		
Operating	[°C]	-20~ 60
Storage (Shipping)	[°C]	-20~ 60

2.2 Optical Characteristics

The optical characteristics are measured under stable conditions at 25 °C:

Item	Unit	Conditions	Min.	Typ.	Max.	Note
Viewing Angle	[degree]	Horizontal (Right) CR > 10 (Left)		89 89	- -	2
		Vertical (Up) CR > 10 (Down)		89 89	- -	
Contrast ratio		Normal Direction	800	1000	-	3
Response Time	[msec]	Raising Time (T _{rR})		10	20	4
		Falling Time (T _{rF})		10	20	
		Raising + Falling		20	40	
Color / Chromaticity Coordinates (CIE)		Red x	0.596	0.646	0.696	5
		Red y	0.283	0.333	0.383	
		Green x	0.255	0.305	0.355	
		Green y	0.565	0.615	0.665	
		Blue x	0.105	0.155	0.205	
		Blue y	0.010	0.060	0.110	
Color Coordinates (CIE) White		White x	0.249	0.299	0.349	5
		White y	0.265	0.315	0.365	
Central Luminance	[cd/m ²]		1600	1800		6
Luminance Uniformity	[%]		80	85		7
Color Gamut	%					

Note 1: Measurement method

The LCD module should be stabilized at given temperature for 30 minutes to avoid abrupt temperature change during measuring (at surface 35°C). In order to stabilize the luminance, the measurement should be executed after lighting Backlight for 30 minutes in a stable, windless and dark room.

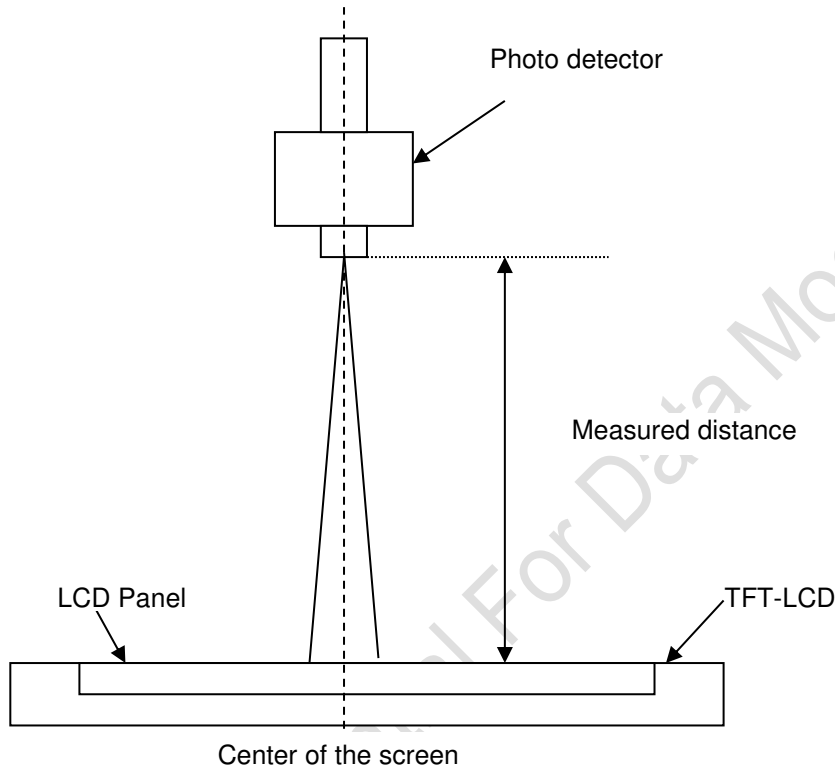

Note 2: Definition of viewing angle measured by ELDIM (EZContrast 88)

Viewing angle is the measurement of contrast ratio ≥ 10 , at the screen center, over a 180° horizontal and 180° vertical range (off-normal viewing angles). The 180° viewing angle range is broken down as follows; 90° (θ) horizontal left and right and 90° (ϕ) vertical, high (up) and low (down). The measurement direction is typically perpendicular to the display surface with the screen rotated about its center to develop the desired measurement viewing angle.

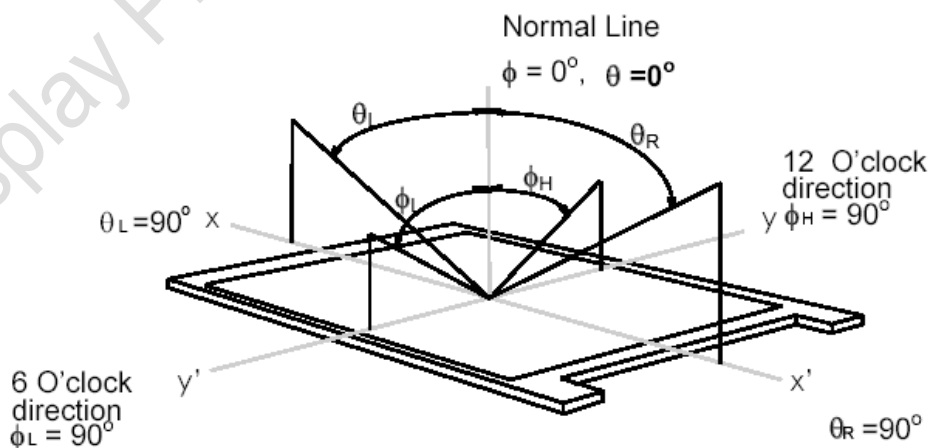

Note 3: Contrast ratio is measured by TOPCON SR-3

Note 4: Definition of Response time measured by Westar TRD-100A

The output signals of photo detector are measured when the input signals are changed from “Full Black” to “Full White” (rising time, T_{rR}), and from “Full White” to “Full Black” (falling time, T_{rF}), respectively. The response time is interval between the 10% and 90% (1 frame at 60 Hz) of amplitudes.
 $T_{rR} + T_{rF} = 20$ msec (typ.).

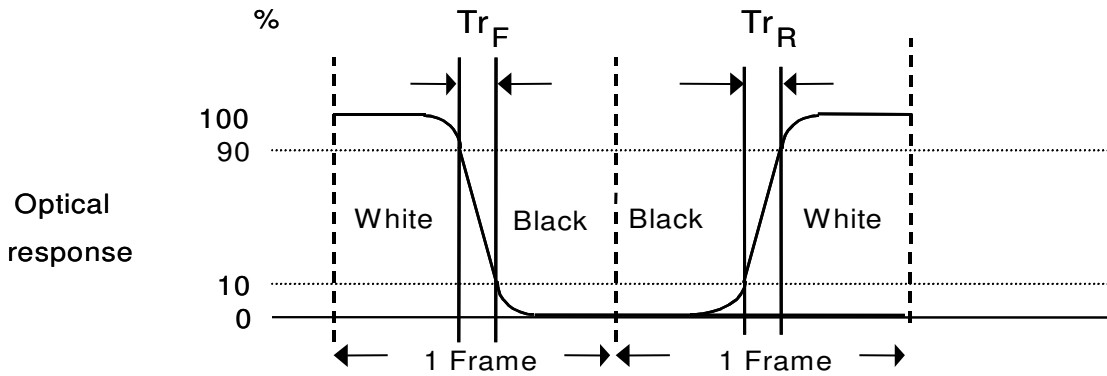

Note 5: Color chromaticity and coordinates (CIE) is measured by TOPCON SR-3

Note 6: Central luminance is measured by TOPCON SR-3

Note 7: Luminance uniformity of these 9 points is defined as below and measured by TOPCON SR-3

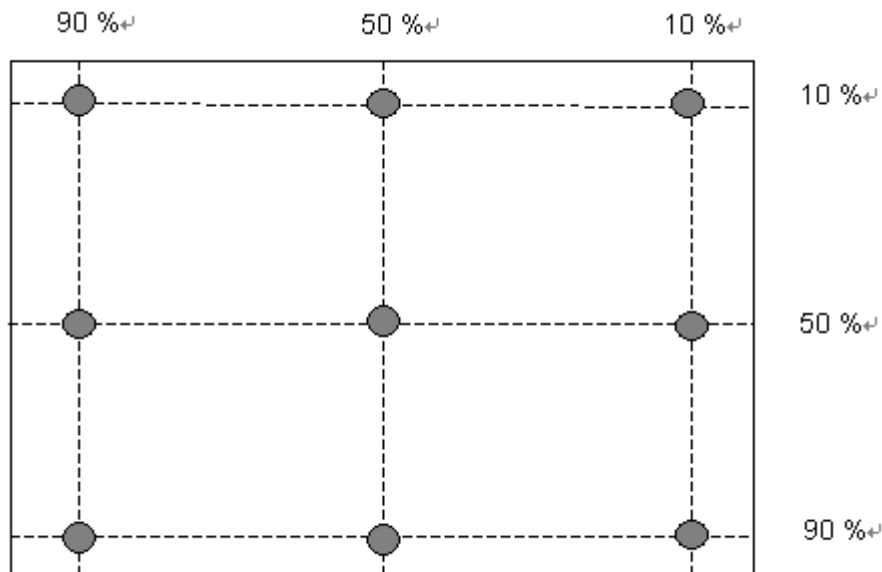

$$\text{Uniformity} = \frac{\text{Minimum Luminance in 9 points(1-9)}}{\text{Maximum Luminance in 9 Points(1-9)}}$$

3. Functional Block Diagram

The following diagram shows the functional block of the 18.5 inch Color TFT-LCD Module:

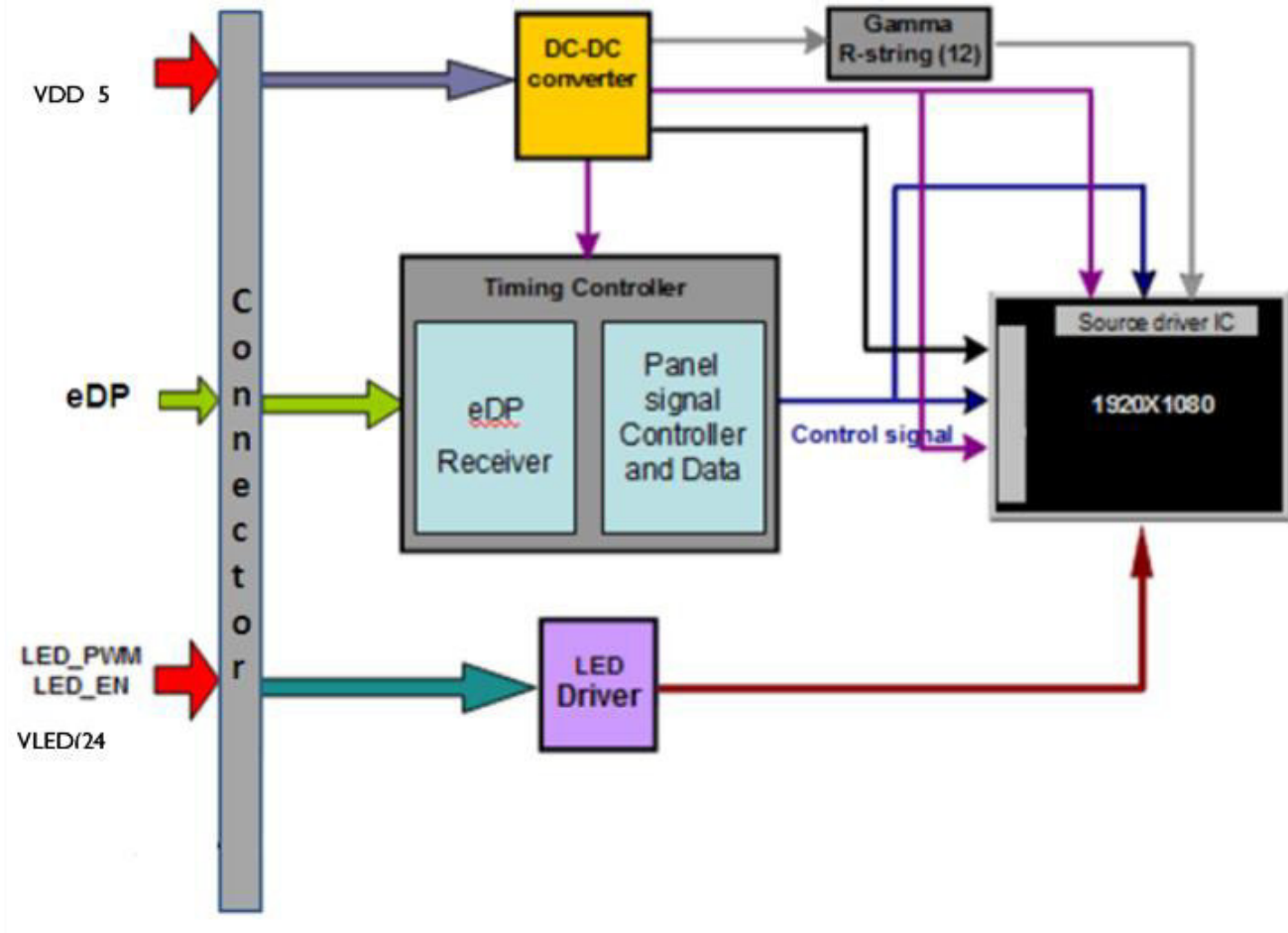

I/F PCB Interface:

I-PEX 20765-030E-11A

Mating Type:

20453-030T-01

4. Absolute Maximum Ratings

Absolute maximum ratings of the module are as following:

4.1 TFT LCD Module

Item	Symbol	Min	Max	Unit	Conditions
Logic/LCD Drive Voltage	VDD	-0.5	+5.5	[Volt]	<i>Note 1,2</i>

4.2 Absolute Ratings of Environment

Item	Symbol	Min.	Max.	Unit	Conditions
Operating Temperature	TOP	-20	60	[°C]	<i>Note 3 & 4</i>
Operation Humidity	HOP	5	95	[%RH]	
Storage Temperature	TST	-20	60	[°C]	
Storage Humidity	HST	5	95	[%RH]	

Note 1: With in Ta (25 °C)

Note 2: Permanent damage to the device may occur if exceeding maximum values

Note 3: For quality performance, please refer to AUO IIS(Incoming Inspection Standard).

Note 4: Operation Temperature +60°C is defined as ambient temperature.

5. Electrical characteristics

5.1 TFT LCD Module

5.1.1 Power Specification

Input power specifications are as follows:

Symbol	Parameter	Min	Typ	Max	Unit	Conditions
VDD	Logic/LCD Drive Voltage	4.5	5	5.5	[Volt]	+/- 10%
IDD	Input Current	-	0.6	0.9	[A]	VDD= 5V, All White Pattern At 60Hz,
PDD	VDD Power	-	3	4.5	[Watt]	VDD= 5V, All White Pattern At 60Hz
IRush	Inrush Current	-	-	3	[A]	Note 1
VDDrp	Allowable Logic/LCD Drive Ripple Voltage	-	-	150	[mV] p-p	VDD= 5V, All White Pattern At 60Hz

Note 1: Maximum Measurement Condition: VDD=5V ,ALL White Pattern

Note 2: Measure condition

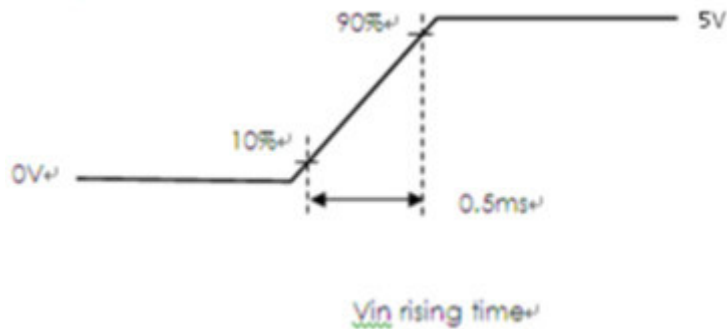
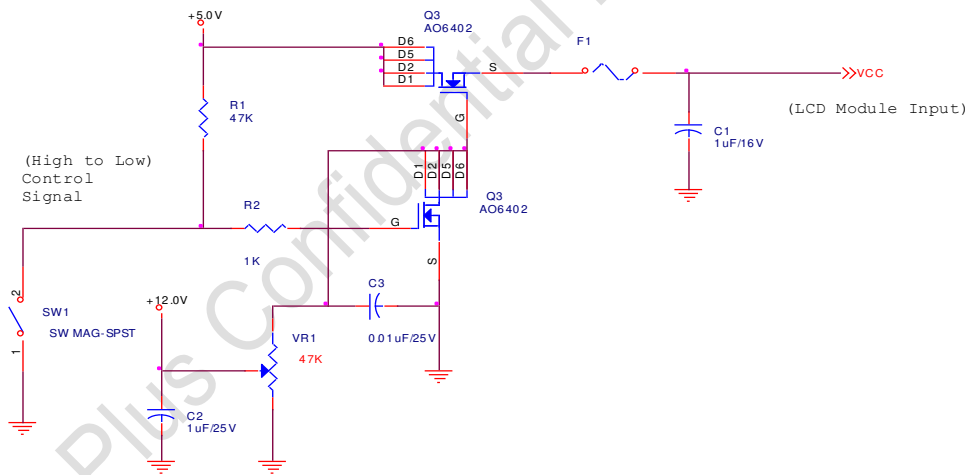

5.1.2 Signal Electrical Characteristics

Signal electrical characteristics are as follows;

Display Port main link signal:

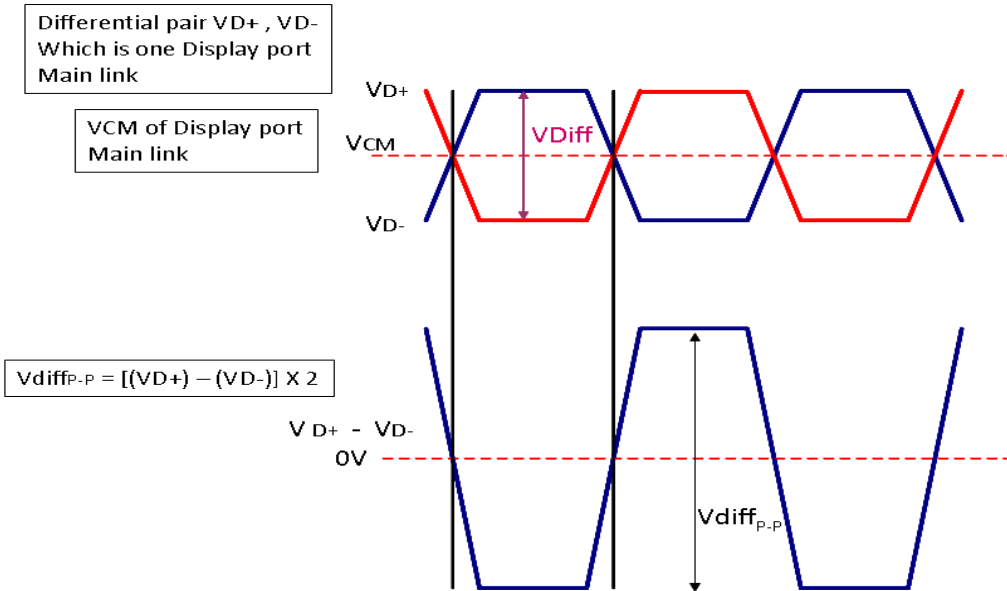

Display port main link		Min	Typ	Max	unit
VCM	RX input DC Common Mode Voltage		0		V
VDiff _{P-P}	Peak-to-peak Voltage at a receiving Device	150		1320	mV

Follow as VESA display port standard V1.2

Display Port AUX_CH signal:

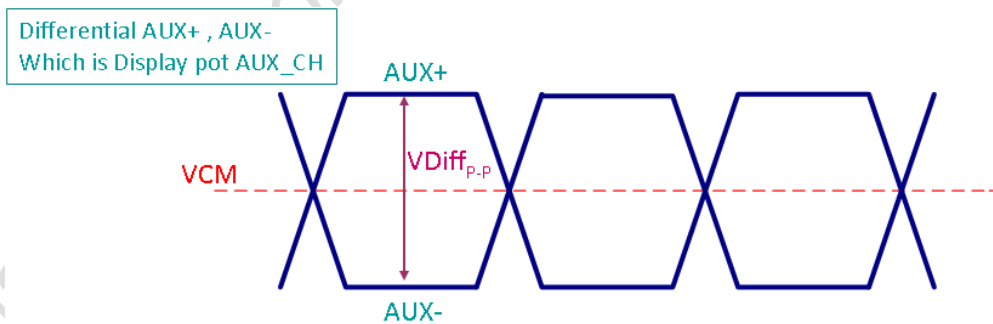

Display port AUX_CH		Min	Typ	Max	unit
VCM	AUX DC Common Mode Voltage		0		V
VDiff _{P-P}	AUX Peak-to-peak Voltage at a receiving Device	0.4	0.6	0.8	V

Follow as VESA display port standard V1.2

Display Port VHPD signal:

Display port VHPD					
		Min	Typ	Max	unit
VHPD	HPD Voltage	2.7	-	3.6	V

Follow as VESA display port standard V1.2

5.2 Backlight Unit

Following characteristics are measured under a stable condition at 25 °C (Room Temperature):

Symbol	Parameter	Min.	Typ.	Max.	Unit	Remark
VCC	Input Voltage	21.8	24	26.4	[Volt]	
I _{VCC}	Input Current		1.8	2	[A]	100% PWM Duty
P _{VCC}	Power Consumption		43.2	48	[Watt]	100% PWM Duty
I _{rush LED}	Inrush Current	-	-	3.5	[A]	
V _{LED on/off}	On Control Voltage	3	5	5.5	Volt	
	Off Control Voltage			0.8	Volt	
F _{PWM}	Dimming Frequency	200	-	15k	[Hz]	
	Swing Voltage	3	3.3	5	V	
	High Voltage	3	3.3	5	Volt	
	Low Voltage			0.8	Volt	
	Dimming Duty 200~5K	5	-	100	%	
	Dimming Duty 5K~15K	15		100	%	
I _F	LED Forward Current		94		mA	T _a = 25 °C
V _F	LED Forward Voltage	-	3.0	3.4	Volt	I _F = 94mA, T _a = 25°C
P _{LED}	LED Power Consumption	-	35.53	40.27	Watt	I _F = 94mA, T _a = 25°C
Operation Lifetime		50,000			Hrs	I _F = 94mA, T _a = 25°C

Note 1: T_a means ambient temperature of TFT-LCD module.

Note 2: V_{CC}, I_{VCC}, P_{VCC}, I_{rush LED} are defined for LED B/L.(100% duty of PWM dimming)

Note 3: I_F, V_F, P_{LED} are defined for single LED.

Note 4: If G185HAN01.4 module is driven by high current or at high ambient temperature & humidity condition. The operating



life will be reduced.

Note 5: Operation life means brightness goes down to 50% initial brightness. Minimum operating life time is estimated data.

Note 6: Each LED light bar consists of 63 pcs LED package (7 strings x 9 pcs / string); There are two Light bars.

AUO Display Plus Confidential For Data Modul Use Only

6. Signal Characteristic

6.1 Pixel Format Image

Following figure shows the relationship of the input signals and LCD pixel format.

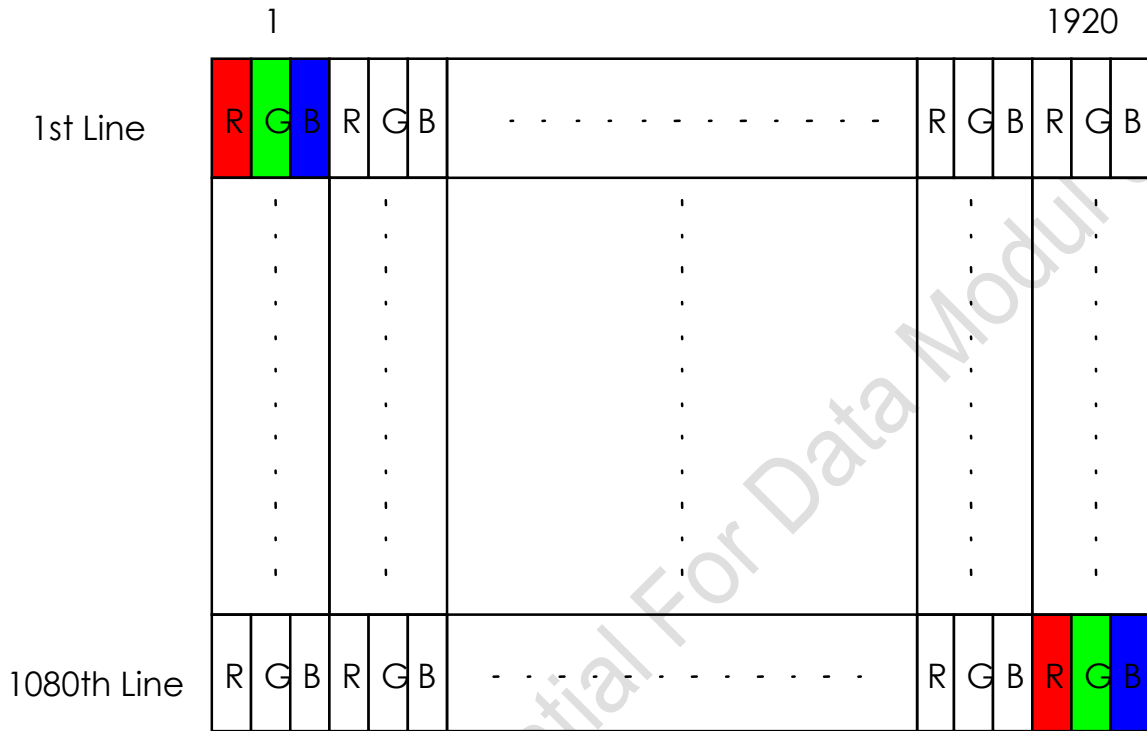

6.2 Scanning Direction

The following figures show the image seen from the front view. The arrow indicates the direction of scan.



6.3 Signal Description

The module uses a eDP receiver embedded in AUO’s ASIC. eDP is a differential signal technology for LCD interface and a high-speed data transfer device.

6.3.1 TFT LCD Module Connector Description

Physical interface is described as for the connector on module.

These connectors are capable of accommodating the following signals and will be following components.

Connector Name / Designation	For Signal Connector
Manufacturer	IPEX or compatible
Type / Part Number	IPEX 20765-030E-11A or compatible
Mating Housing/Part Number	IPEX 20453-030T-01 or Compatible

6.3.2 TFT LCD Module Pin Assignment

PIN NO	Symbol	Function
1	NC	No Connect (Reserved for CM)
2	NC	No Connect
3	NC	No Connect
4	NC	No Connect
5	NC	No Connect
6	NC	No connect (Reverse for AUO TEST only)
7	NC	No connect (Reverse for AUO TEST only)
8	NC	No Connect
9	NC	No Connect
10	NC	No Connect
11	LCD GND	LCD logic and driver ground
12	LCD GND	LCD logic and driver ground
13	LCD GND	LCD logic and driver ground
14	HPD	HPD signal pin
15	LCD GND	LCD logic and driver ground
16	LCD GND	LCD logic and driver ground
17	LCD_Self_Test	No connect(Reverse for LCD panel shelf test Enable)
18	LCD_VCC	LCD logic and driver power

19	LCD_VCC	LCD logic and driver power
20	H_GND	High Speed Ground
21	AUX_CH_N	Comp Signal Auxiliary Ch.
22	AUX_CH_P	True Signal Auxiliary Ch.
23	H_GND	High Speed Ground
24	Lane0_P	True Signal Link Lane 0
25	Lane0_N	Comp Signal Link Lane 0
26	H_GND	High Speed Ground
27	Lane1_P	True Signal Link Lane 1
28	Lane1_N	Comp Signal Link Lane 1
29	H_GND	High Speed Ground
30	NC	No Connect

Note1: Start from left side.

Note2: Input signals shall be low or High-impedance state when VDD is off.

Note3: Internal circuit of **eDP inputs** are as following.

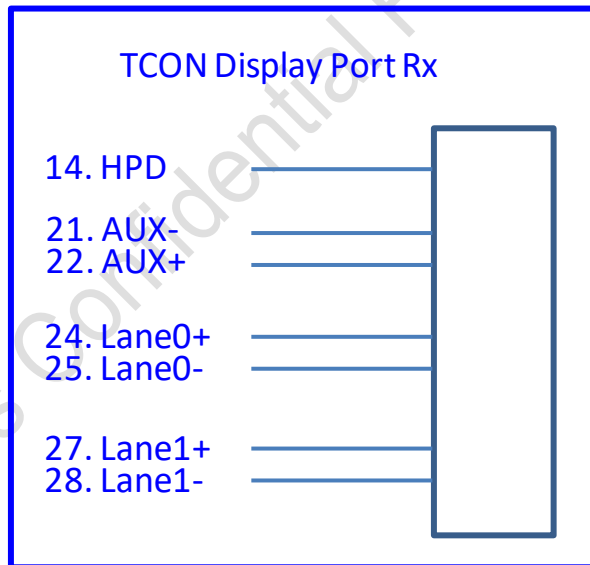

6.3.3 BLU Connector

Connector Name / Designation	Signal Connector
Manufacturer	J.S.T ELECTRONICE Co.,Ltd.
Connector Model Number	SM08B-GHH-TB(HF)

Pin	Symbol	Function	Remark
1	BL_PWR	Backlight power	
2	BL_PWR	Backlight power	
3	BL_PWR	Backlight power	
4	BL_GND	Backlight ground	
5	BL_GND	Backlight ground	
6	BL_GND	Backlight ground	
7	BL_EN	Backlight On / Off	
8	LED_PWM	PWM signal input	

6.4 Interface Timing

6.4.1 Timing Characteristics

Basically, interface timings should match the 1920x1080 /60Hz manufacturing guide line timing.

Parameter	Symbol	Min.	Typ.	Max.	Unit	
Frame Rate	-	-	60	-	Hz	
Clock frequency	$1 / T_{Clock}$		141		MHz	
Vertical Section	Period	T_V	1112	1116	1080+A	T_{Line}
	Active	T_{VD}	1080			
	Blanking	T_{VB}	32	36	A	
Horizontal Section	Period	T_H	2062	2104	1920+B	T_{Clock}
	Active	T_{HD}	1920			
	Blanking	T_{HB}	142	184	B	

Note1: DE mode only

Note2: The maximum clock frequency = $(1920+B) \cdot (1080+A) \cdot 60 < 143\text{MHz}$

Note3: Typical value refer to VESA STANDARD

6.4.2 Input Timing Diagram

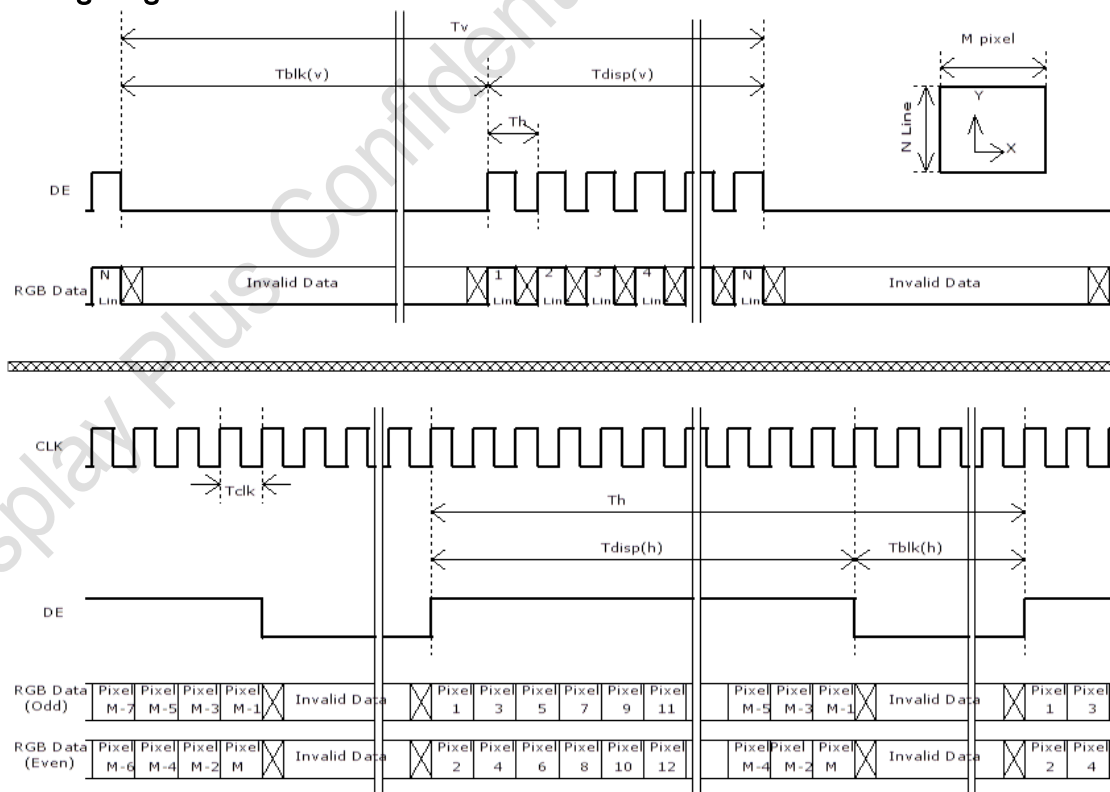

6.5 Power ON/OFF Sequence

Power on/off sequence is as follows. Interface signals and LED on/off sequence are also shown in the chart. Signals from any system shall be Hi-Z state or low level when VDD is off

Display Port panel power sequence:

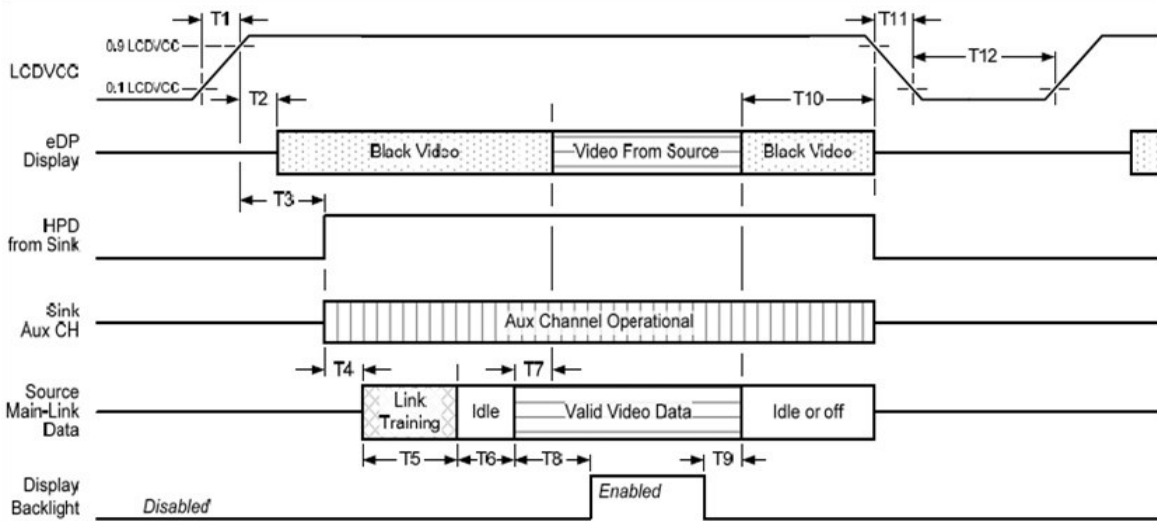

Display port interface power up/down sequence, normal system operation

Display Port AUX_CH transaction only:

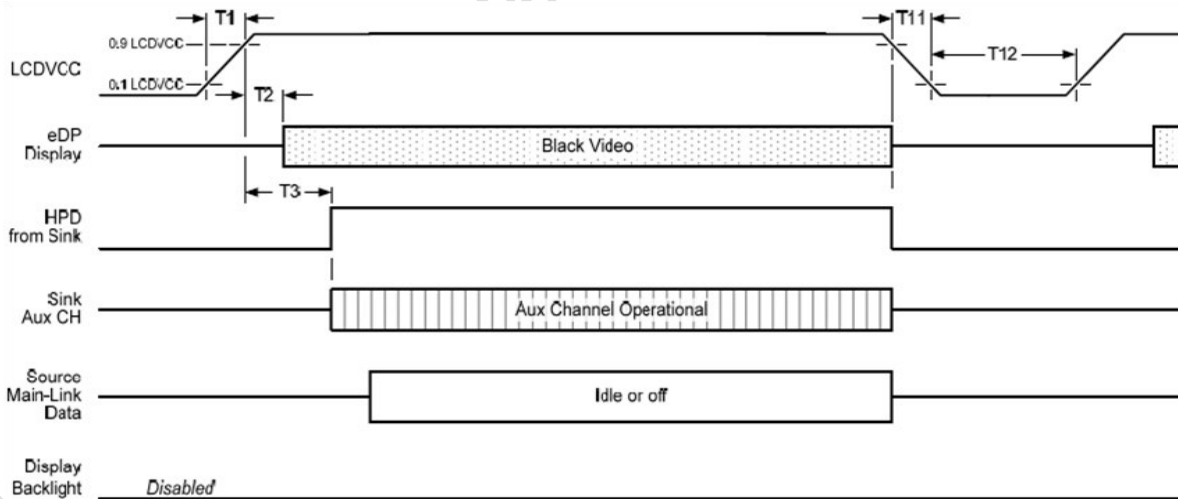

Display port interface power up/down sequence, AUX_CH transaction only

Display Port panel power sequence timing parameter:

Timing parameter	Description	Reqd. by	Limits			Notes
			Min.	Typ.	Max.	
T1	power rail rise time, 10% to 90%	source	0.5ms		10ms	
T2	delay from LCDVDD to black video generation	sink	0ms		200ms	prevents display noise until valid video data is received from the source
T3	delay from LCDVDD to HPD high	sink	0ms		200ms	sink AUX_CH must be operational upon HPD high.
T4	delay from HPD high to link training initialization	source				allows for source to read link capability and initialize.
T5	link training duration	source				dependant on source link to read training protocol.
T6	link idle	source				Min accounts for required BS-Idle pattern. Max allows for source frame synchronization.
T7	delay from valid video data from source to video on display	sink	0ms		50ms	max allows sink validate video data and timing.
T8	delay from valid video data from source to backlight enable	source				source must assure display video is stable.
T9	delay from backlight disable to end of valid video data	source				source must assure backlight is no longer illuminated.
T10	delay from end of valid video data from source to power off	source	0ms		500ms	
T11	power rail fall time, 90% to 10%	source			10ms	
T12	power off time	source	500ms			

Note 1: The sink must include the ability to generate black video autonomously. The sink must automatically enable black video under the following conditions:

- upon LCDVDD power on (with in T2 max)-when the "Novideostream_Flag" (VB-ID Bit 3) is received from the source (at the end of T9).

- when no main link data, or invalid video data, is received from the source. Black video must be displayed within 64ms (typ) from the start of either condition. Video data can be deemed invalid based on MSA and timing information, for example.

Note 2: The sink may implement the ability to disable the black video function, as described in Note 1, above, for system development and debugging purpose.

Note 3: The sink must support AUX_CH polling by the source immediately following LCDVDD power on without causing damage to the sink device (the source can re-try if the sink is not ready). The sink must be able to respond to an AUX_CH transaction with the time specified within T3 max.

Display Port panel B/L power sequence timing parameter:

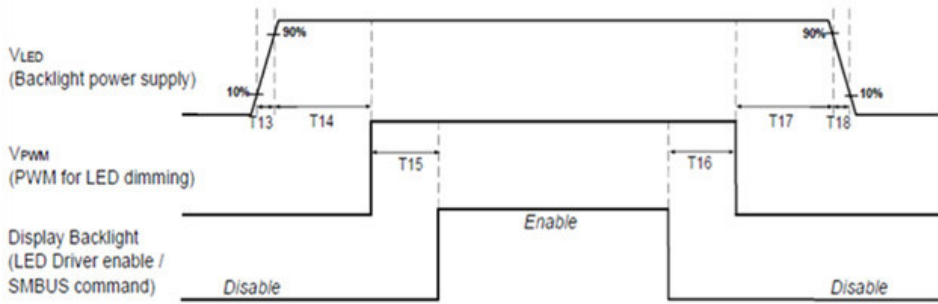

Note : When the adapter is hot plugged, the backlight power supply sequence is shown as below.

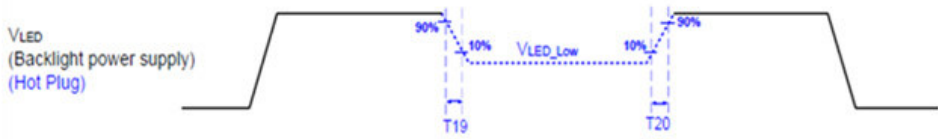

	Min (ms)	Max (ms)
T13	0.5	10
T14	10	-
T15	10	-
T16	10	-
T17	10	-
T18	0.5	10
T19	1 [*]	-
T20	1 [*]	-

Seamless change: $T19/T20 = 5 \times T_{PWM}^*$

* $T_{PWM} = 1/PWM$ Frequency

7. Reliability Test

Environment test conditions are listed as following table.

Items	Required Condition	Note
Temperature Humidity Bias (THB)	Ta= 50°C, 80%RH, 300hours	
High Temperature Operation (HTO)	Ta= 60°C, 300hours	3
Low Temperature Operation (LTO)	Ta= -20°C, 300hours	
High Temperature Storage (HTS)	Ta= 60°C, 300hours	
Low Temperature Storage (LTS)	Ta= -20°C, 300hours	
Vibration Test (Non-operation)	Acceleration: 1.5 G Wave: Random Frequency: 10 - 200 Hz Sweep: 30 Minutes each Axis (X, Y, Z)	
Shock Test (Non-operation)	Acceleration: 50 G Wave: Half-sine Active Time: 20 ms Direction: ±X, ±Y, ±Z (one time for each Axis)	
Thermal Shock Test (TST)	-20°C /30min, 60°C /30min, 100 cycles	1
On/Off Test	On/10sec, Off/10sec, 30,000 cycles	
ESD (Electro Static Discharge)	Contact Discharge: ± 8KV, 150pF(330Ω) 1sec, 8 points, 25 times/ point.	2
	Air Discharge: ± 15KV, 150pF(330Ω) 1sec 8 points, 25 times/ point.	

Note 1: The TFT-LCD module will not sustain damage after being subjected to 100 cycles of rapid temperature change. A cycle of rapid temperature change consists of varying the temperature from -20°C to 60°C, and back again. Power is not applied during the test. After temperature cycling, the unit is placed in normal room ambient for at least 4 hours before power on.

Note 2: According to EN61000-4-2 , ESD class B: Some performance degradation allowed. No data lost. Self-recoverable. No hardware failures.

Note 3: No function occurs Mura shall be ignored after high temperature reliability test.

8. Shipping Label & Packaging

8.1 Shipping Label

The label is on the panel as shown below:

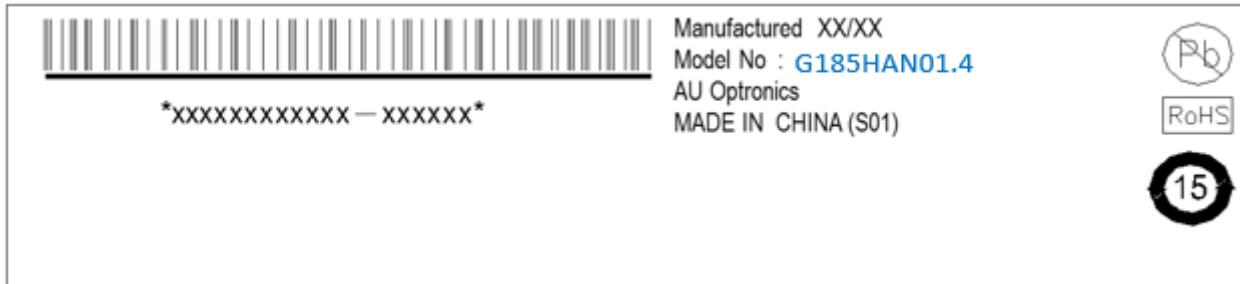

Note 1: For Pb Free products, AUO will add  for identification.

Note 2: For RoHS compatible products, AUO will add  for identification.

Note 3: For China RoHS compatible products, AUO will add  for identification.

Note 4: The Green Mark will be presented only when the green documents have been ready by AUO Internal Green Team.

8.2 Packaging

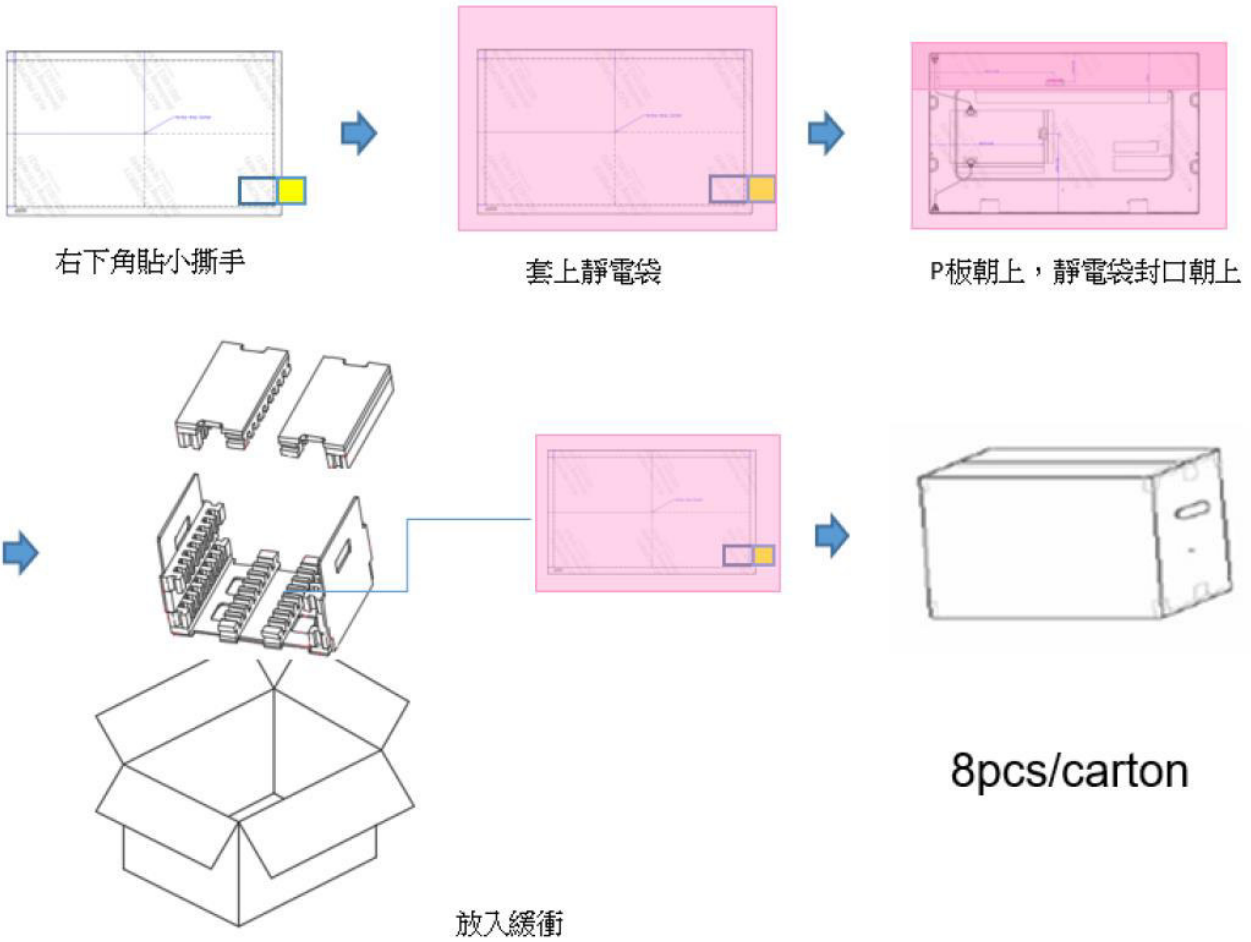

Max capacity : 8 TFT-LCD module per carton

Max weight: 12.3 kg per carton

Outside dimension of carton: 520mm(L)*365mm(W)*360mm (H)

Pallet size : 1150mm * 1070 mm * 132mm

8.3 Palletizing

Box stacked

Module by air : (2*3) *4 layers , one pallet put 24 boxes , total 192pcs module

Module by sea : One pallet (2*3) *4 layers + One pallet (2*3) *1layers , total 240pcs module

Module by sea_ HQ : One pallet (2*3) *4 layers + One pallet (2*3) *2 layers , total 288pcs module

AUO Display Plus Confidential For Data Modul Use Only



Product Specification

G185HAN01.4

AU OPTRONICS CORPORATION

9.Mechanical Characteristics

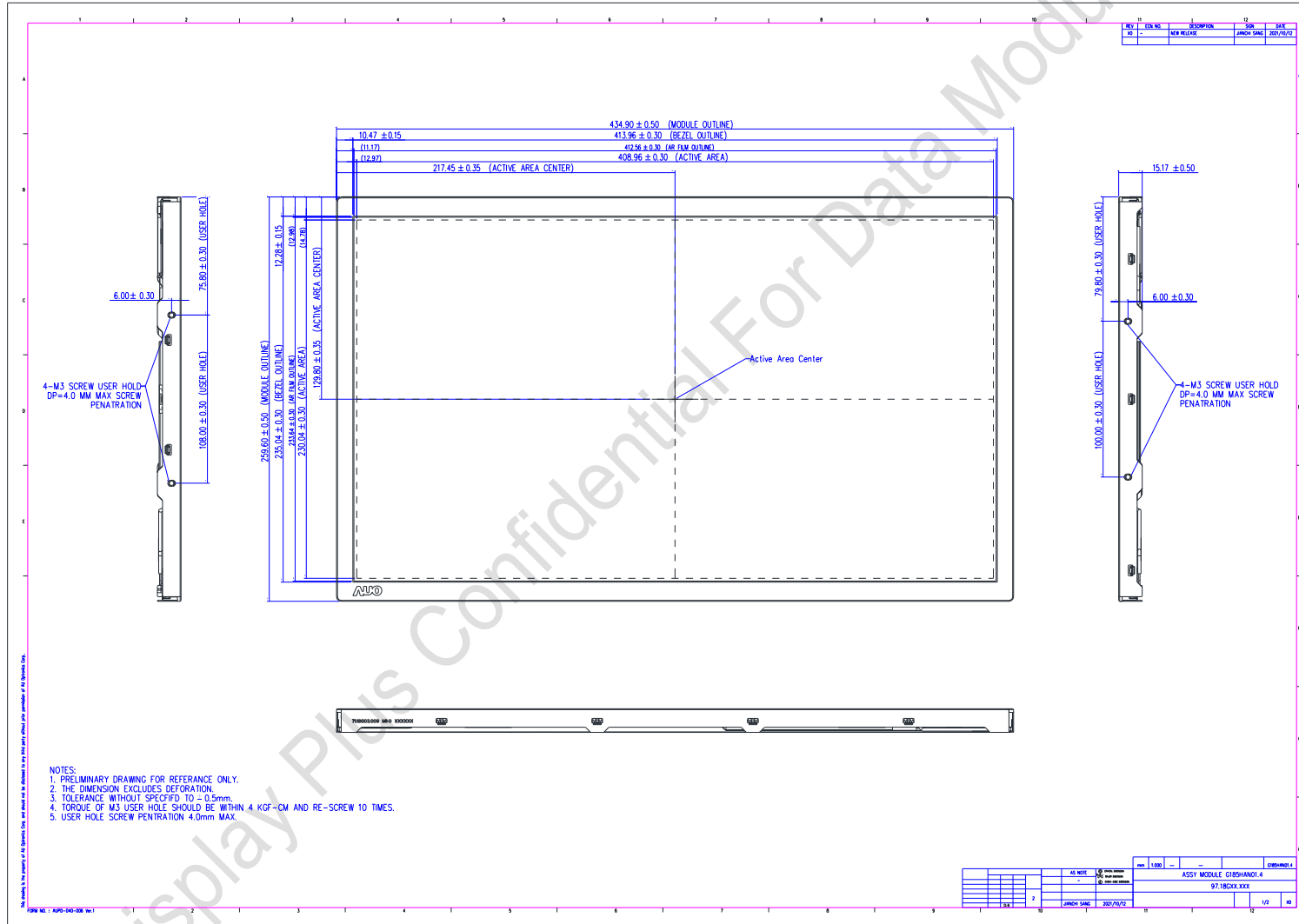



Product Specification

AU OPTRONICS CORPORATION

G185HAN01.4

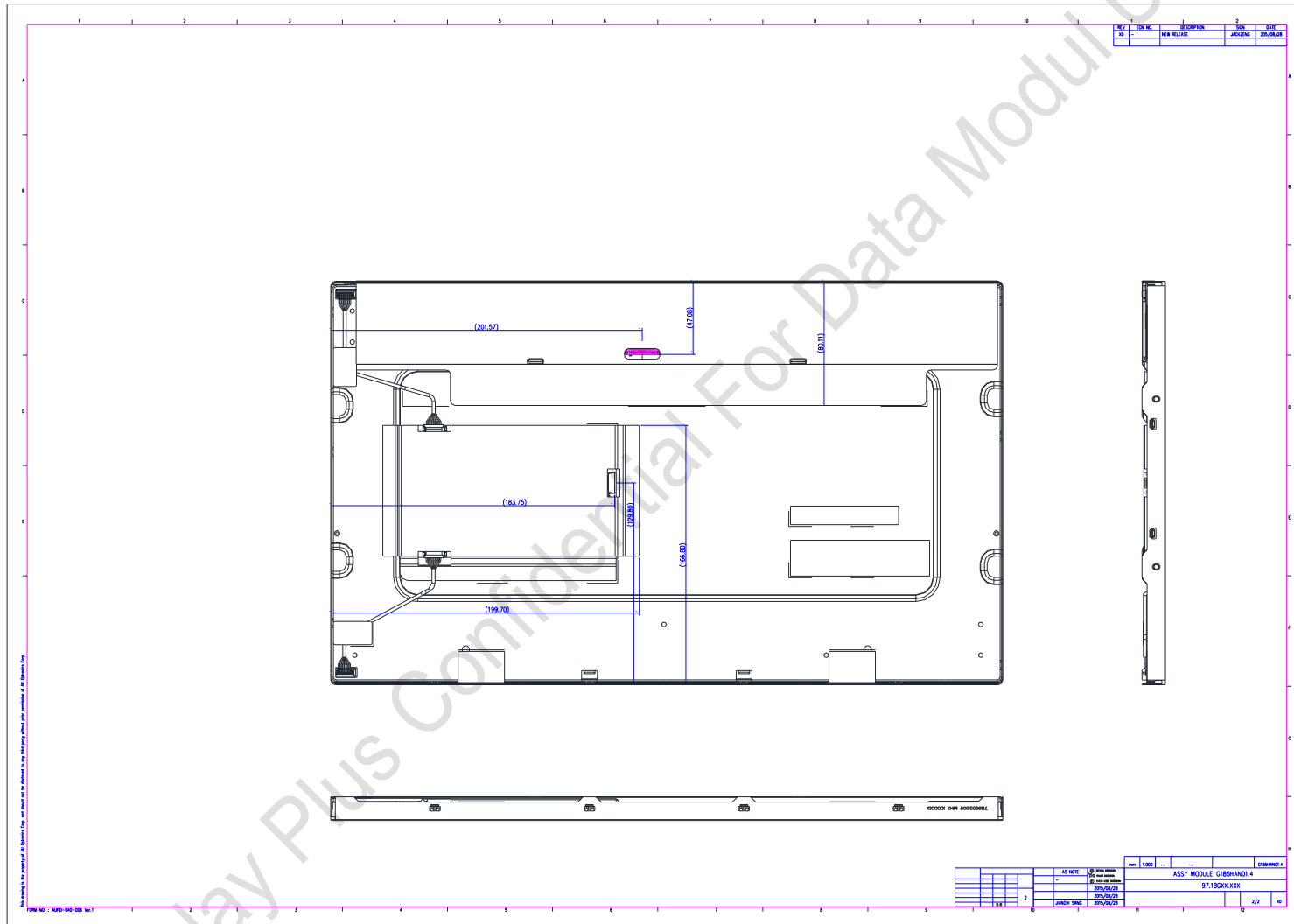

10. Safety

10.1 Sharp Edge Requirements

There will be no sharp edges or comers on the display assembly that could cause injury.

10.2 Materials

10.2.1 Toxicity

There will be no carcinogenic materials used anywhere in the display module. If toxic materials are used, they will be reviewed and approved by the responsible AUO toxicologist.

10.2.2 Flammability

All components including electrical components that do not meet the flammability grade UL94-V1 in the module will complete the flammability rating exception approval process.

The printed circuit board will be made from material rated 94-V1 or better. The actual UL flammability rating will be printed on the printed circuit board.

10.3 Capacitors

If any polarized capacitors are used in the display assembly, provisions will be made to keep them from being inserted backwards.

10.4 National Test Lab Requirement

The display module will satisfy all requirements for compliance to:

UL 60950-1, Second Edition

U.S.A. Information Technology Equipment



ALL TECHNOLOGIES. ALL COMPETENCIES. ONE SPECIALIST.

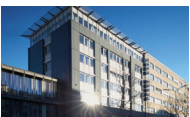

DATA MODUL AG
Landsberger Straße 322 DE-
80687 Munich
Phone: +49-89-56017-0

DATA MODUL WEIKERSHEIM GMBH
Lindenstraße 8
DE-97990 Weikersheim Phone:
+49-7934-101-0



More information and worldwide locations can be found at

www.data-modul.com