



SPECIFICATION

ORTUSTECH

COM121H9M21SSS

12.1" – 1024 x 768 – LVDS – Blanview

Version: 0.1

Date: 08.06.2023

Note: This specification is subject to change without prior notice

This product is under development and specifications are subject to change.

Specifications for Blanview TFT-LCD Monitor (TENTATIVE) (12.1" XGA 1024 x RGB x 768 Landscape)

Version 0.1

(Please be sure to check the specifications latest version.)

 MODEL COM121H9M21SSS

Customer's Approval

Signature :

Name :

Section :

Title :

Date :

ORTUSTECH

 TOPPAN INC.
Electronics Division
Technological Development Department III

Approved by

Checked by

Prepared by

Contents

1. Application	4
2. Outline Specifications		
2.1 Features of the Product	5
2.2 Display Method	5
3. Dimensions and Shape		
3.1 Dimensions	7
3.2 Outward Form	8
3.3 Serial Label (S-Label)	9
4. Pin Assignment	10
5. Absolute Maximum Rating	12
6. Electrical Characteristics		
6.1 DC Characteristics	13
6.2 LVDS Interface	14
6.3 Input Timing Specifications	17
6.4 Power ON/OFF Sequence	18
7. Characteristics		
7.1 Optical Characteristics	19
8. Criteria of Judgment		
8.1 Defective Display and Screen Quality	20
8.2 Screen and Other Appearance	21
9. Reliability Test	22
10. Packing Specifications	24
11. Handling Instruction		
11.1 Cautions for Handling LCD panels	25
11.2 Precautions for Handling	26
11.3 Precautions for Operation	26
11.4 Storage Condition for Shipping Cartons	27
11.5 Precautions for Peeling off the Protective film	28
11.6 Warranty	28
APPENDIX	29

1. Application

This Specification is applicable to 307.2 mm (12.1 inch) Blanview TFT-LCD monitor for non-military use.

- ◎ TOPPAN makes no warranty or assume no liability that use of this Product and/or any information including drawings in this Specification by Purchaser is not infringing any patent or other intellectual property rights owned by third parties, and TOPPAN shall not grant to Purchaser any right to use any patent or other intellectual property rights owned by third parties. Since this Specification contains TOPPAN's confidential information and copy right, Purchaser shall use them with high degree of care to prevent any unauthorized use, disclosure, duplication, publication or dissemination of TOPPAN's confidential information and copy right.
- ◎ If Purchaser intends to use this Products for an application which requires higher level of reliability and/or safety in functionality and/or accuracy such as transport equipment (aircraft, train, automobile, etc.), disaster-prevention/security equipment or various safety equipment, Purchaser shall consult TOPPAN on such use in advance.
- ◎ This Product shall not be used for application which requires extremely higher level of reliability and/or safety such as aerospace equipment, telecommunication equipment for trunk lines, control equipment for nuclear facilities or life-support medical equipment.
- ◎ It must be noted as an mechanical design manner, especial attention in housing design to prevent arcuation/flexure caused by stress to the LCD module shall be considered.
- ◎ TOPPAN assumes no liability for any damage resulting from misuse, abuse, and/or miss-operation of the Product deviating from the operating conditions and precautions described in the Specification.
- ◎ It shall be mutually conferred if nonconforming defect which result from unspecified cause in this specification arises.
- ◎ If any issue arises as to information provided in this Specification or any other information, TOPPAN and Purchaser shall discuss them in good faith and seek solution.
- ◎ TOPPAN assumes no liability for defects such as electrostatic discharge failure occurred during peeling off the protective film or Purchaser's assembly process.
- ◎ This Product is compatible for RoHS(2.0) directive.

Object substance	Maximum content [ppm]
Cadmium and its compound	100
Hexavalent Chromium Compound	1000
Lead & Lead compound	1000
Mercury & Mercury compound	1000
Polybrominated biphenyl series (PBB series)	1000
Polybrominated biphenyl ether series (PBDE series)	1000
Bis(2-ethylhexyl)phthalate series(DEHP series)	1000
Butyl benzyl phthalate series(BBP series)	1000
Dibutyl phthalate series(DBP series)	1000
Diisobutyl phthalate series(DIBP series)	1000

2. Outline Specifications

2.1 Features of the Product

12.1 inch diagonal display, 1024 x RGB [H] x 768 [V] dots.

16.7 Million colors / 262 thousand colors.

Timing generator [TG], Counter-electrode driving circuitry, Built-in power supply circuit.

High bright white LED back-light, Built-in backlight drive circuit.

2.2 Display Method

Items	Specifications	Remarks
Display type	FFS 16.7 Million colors / 262 thousand colors. Normally black.	
Driving method	a-Si TFT Active matrix. Line-scanning, Non-interlace.	
Dot arrangement	RGB stripe arrangement.	Refer to "Dot arrangement"
Signal input method	VESA/JEIDA LVDS Interface.	
Backlight type	High bright white LED.	
NTSC ratio	(50%)	

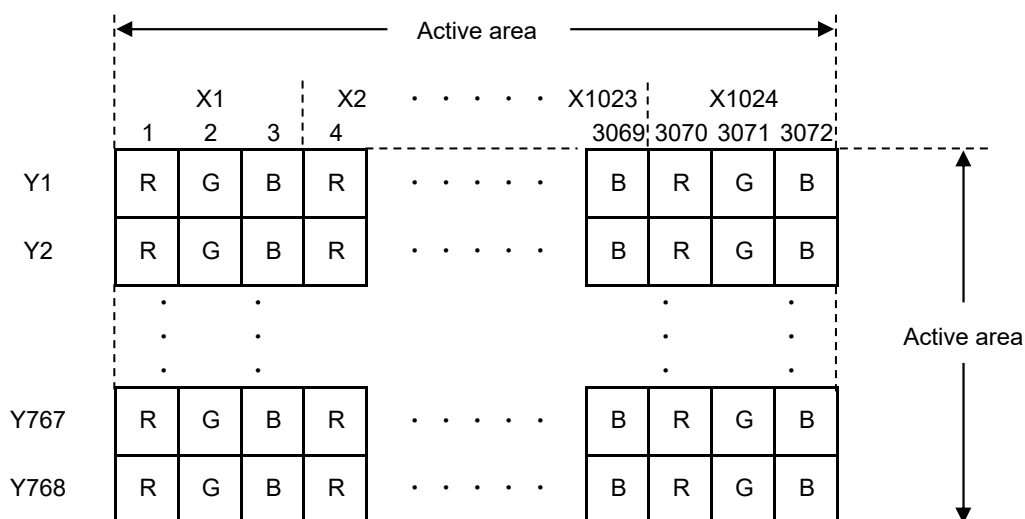
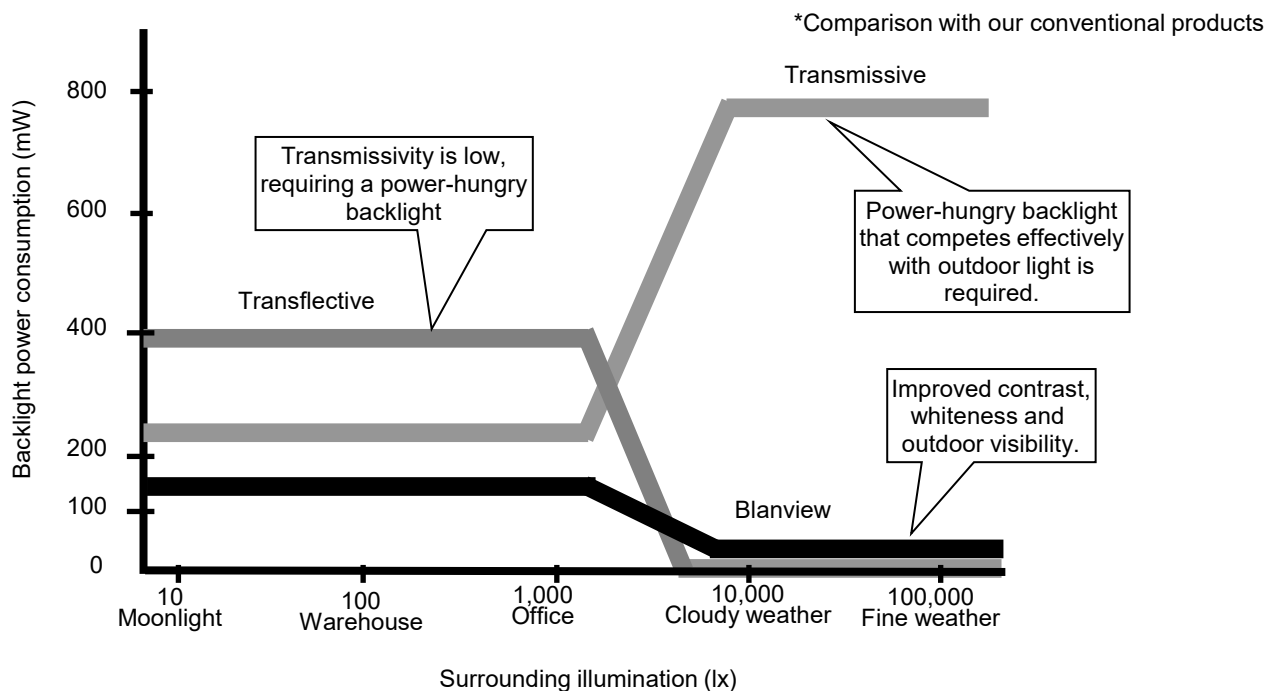

Fig.1 Dot arrangement

<Features of Blanview>

- Backlight power consumption required to assure visibility. (equivalent to 3.5"QVGA)



- Contrast characteristics under 100,000lx. (same condition as direct sunlight.)

With better contrast (higher contrast ratio), Blanview TFT-LCD has the best outdoor readability in three different types of TFT-LCD.

Below chart shows contrast value against panel surface brightness. (Horizontal: Panel surface brightness/ Vertical: Contrast value) LCD panel has enough outdoor readability above our Standard line. (TOPPAN criteria)

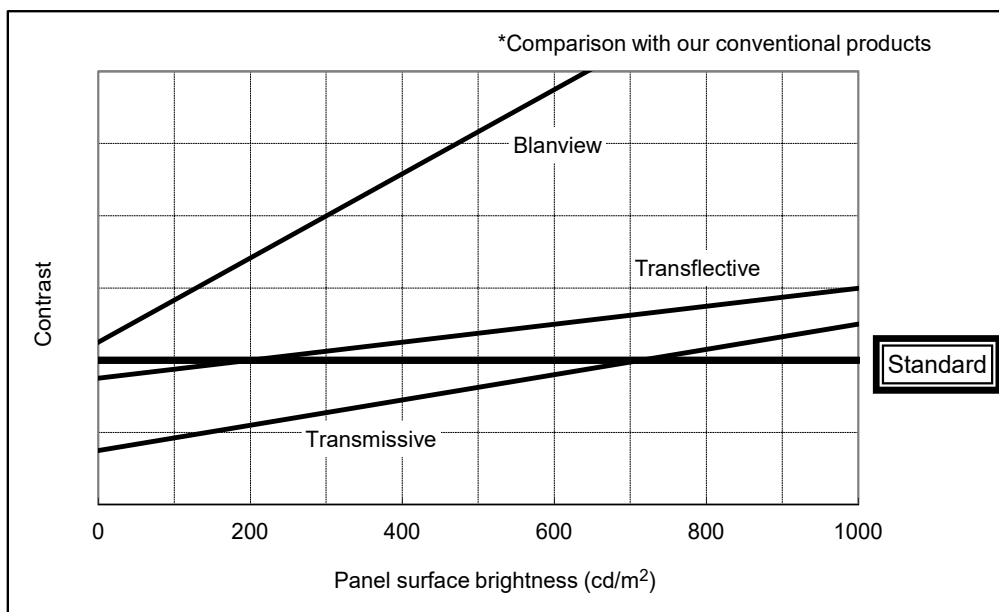

3. Dimensions and Shape

3.1 Dimensions

Items	Specifications	Unit	Remarks
Outline dimensions	260.5 [H] × 203.0 [V] × 9.5 [D]	mm	
Active area	245.76 [H] × 184.32 [V]	mm	Diagonal 307.20 mm
Number of dots	3072 [H]×768 [V]	dot	
Dot pitch	80 [H]×240 [V]	um	
Weight	(510)	g	

3.2 Outward Form

EC No.	REV. No.	REVISE	DATE (Y:M:D)	APPROVED	CHECKED	PREPARED
###			##:##:##	##	##	

(8/30)
22TLM115
Issue: Jun.8,2023

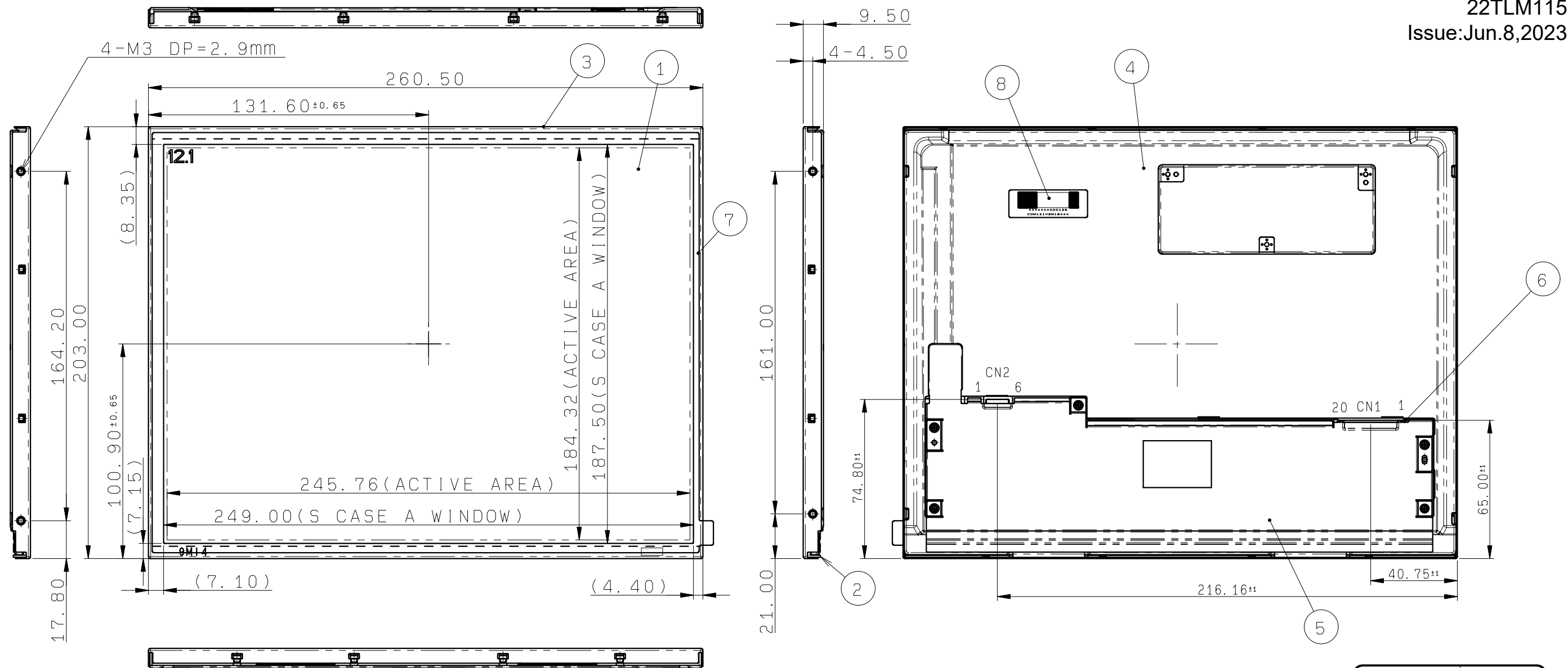

参考図 2022.07.04
本図は参考図面です。

Note: 1. Connector:

CN1:FI-SEB20P-HFE(JAE)
CN2:FI-S6P-HFE(JAE)

注 1. コネクタ:

CN1:FI-SEB20P-HFE(JAE)
CN2:FI-S6P-HFE(JAE)

Note: 2. Internal thread:

The internal thread part is 0.65 mm inside from the surface.
So the screw length of insert part is longer than 2.2mm
The tightening torque shall be 0.5 Nm or less.

注 2. ねじ部:

めねじ部のねじ山は表面より0.65mm内側になります。表面から2.2mm以上挿入する設計を推奨します。
締め付けトルクは0.5Nm以下としてください。

S LABEL	8		
Protective Film	7		
PCB A	6		
S CASE D	5		t=0.3
S CASE C	4		AL t=0.8
S CASE A	3		t=0.5
FRAME	2		PC
TFT PANEL	1		Glass substrate thickness 0.5t+0.5t
PART NAME	ITEM	PART CODE	MODEL NUMBER

APPROVED 木下	GENERAL TOLERANCE ±0.5	SCALE 1/2	UNIT mm
CHECKED 加藤	ISSUE (Y:M:D) 22:07:04	MODEL COM121H9M21***	
CHECKED	NAME		
DESIGN 増田剛			
DRAW 増田剛			
OUTLINE-D9M21			
DO NOT DUPLICATE, CONFIDENTIAL AND PROPRIETARY			
DRAWING No. SJD603090D301		REV. #	SHEET /

3.3 Serial Label (S-label)

3.3.1 Display Items

A section : Bar code

B section : Combination of a character

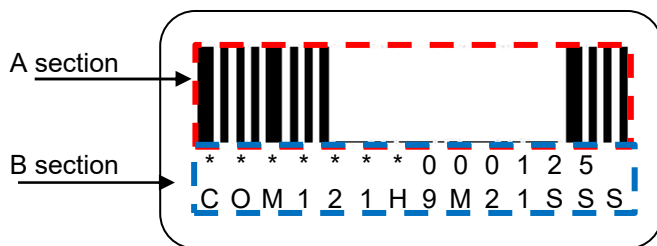

Details of B section

Upper column: It indicates The least significant digit of manufacture year (1 digit), manufacture month with below alphabet (1letter), model code (5characters), serial number (6digits).

*	*	*****	*****
—	—	—	—
a	b	c	d

Contents of display							
a	The least significant digit of manufacture year						
b	Manufacture month	Jan-A	Mar-C	May-E	Jul-G	Sep-I	Nov-K
		Feb-B	Apr-D	Jun-F	Aug-H	Oct-J	Dec-L
c	Model code	121JS (Made in Japan) 121KS (Made in Malaysia)					
d	Serial number						

* Example of indication of Serial label (S-label)

•Made in Japan

3L121JS000125

means "manufactured in December 2023, 12.1 inch, J type S specifications, serial number 000125"

•Made in Malaysia

3L121KS000125

means "manufactured in December 2023, 12.1 inch, K type S specifications, serial number 000125"

Lower column: Model (14characters)

3.3.2 Location of Serial Label (S-label)

Refer to 3.2 "Outward Form".

3.3.3 Others

Bar code readability is excluded from quality assurance coverage.

4. Pin Assignment

LCD_CN

№	Symbol	Details
1	VCC	Power supply (3.3V)
2	VCC	Power supply (3.3V)
3	GND	Ground
4	GND	Ground
5	Rx0-	LVDS DATA0(-)
6	Rx0+	LVDS DATA0(+)
7	GND	Ground
8	Rx1-	LVDS DATA1(-)
9	Rx1+	LVDS DATA1(+)
10	GND	Ground
11	Rx2-	LVDS DATA2(-)
12	Rx2+	LVDS DATA2(+)
13	GND	Ground
14	CLK-	LVDS CLK(-)
15	CLK+	LVDS CLK(+)
16	GND	Ground
17	Rx3-	LVDS DATA3(-) *Note
18	Rx3+	LVDS DATA3(+) *Note
19	MODE	VESA/JEIDA switching terminal (Low: 8bit_JEIDA or 6bit_JEIDA / High: 8bit_VESA)
20	SC	Display direction switching (Low: Normal display, High: Reverse display)

- Used connector: FI-SEB20P-HFE (JAE)
- Corresponding connector: FI-S20S[for discrete Wire], FI-SE20ME[for FPC] (JAE)
- Please connect using twisted pair cables for stable LVDS signal.

Note) For 6-bits input, set MODE = 0 (JEIDA) and set pin numbers 17, 18 as the following recommended inputs.

- Enter the Low data of the LVDS transmitter in 17 and 18.
- or
- Connect pin 17 to VCC via 680Ω and pin 18 to GND via 620Ω.

BL_CN

No.	Symbol	Details	Remark
1	VL	Power supply (12V)	
2	VL	Power supply (12V)	
3	GNDL	Ground	
4	GNDL	Ground	
5	BLEN	Backlight ON-OFF	High: ON Low: OFF
6	VPDIM	Light Dimmer Control (PWM) input	High active

- Used connector: FI-S6P-HFE (JAE)
- Corresponding connector: FI-S6S (JAE)

- Please make sure to check a consistency between pin assignment in "3.2 Outward Form" and your connector pin assignment when designing your circuit.
Inconsistency in input signal assignment may cause a malfunction.

5. Absolute Maximum Rating

Item	Symbol	Rating		Unit
		MIN	MAX	
LCD Supply Voltage	VCC	-0.3	4.0	V
Input Voltage for Logic	VI	-0.3	VCC+0.3	V
Backlight Power Supply Input Voltage	VL	-0.3	14.0	V
Backlight ON-OFF	BLEN	-0.3	VL	V
Light Dimmer Control (PWM) input Voltage	VPDIM	-0.3	VL	V
Operational temperature range Note1	Top	-30	70	°C
Storage temperature range	Tstg	-30	80	°C

Note1: Panel surface temperature

6. Electrical Characteristics

6.1 DC Characteristics

6.1.1 LCD Display Module

(Unless otherwise noted, Ta=25 °C,VCC=3.3V,GND=0V)

Item	Symbol	Condition	Rating			Unit	Applicable terminal
			MIN	TYP	MAX		
LCD Supply Voltage	VCC		3.0	3.3	3.6	V	VCC
LCD operating current	ICC	Color bars	-	(410)	(820)	mA	VCC
Input Voltage for Logic	VIH		0.8×VCC	-	VCC	V	MODE, SC
	VIL		0	-	0.2×VCC	V	MODE, SC

6.1.2 Backlight

(Unless otherwise noted, Ta=25 °C,VL=12V,GNDL=0V)

Item	Symbol	Condition	Rating			Unit	Applicable terminal
			MIN	TYP	MAX		
Supply Input Voltage	VL		10.8	12.0	13.2	V	VL
Supply Input Current	IL	PWM duty=100%	--	(450)	(900)	mA	VL
Backlight ON-OFF	High_BLEN	ON	2.0	--	VL	V	BLEN
	Low_BLEN	OFF	0	--	0.8	V	
Light Dimmer Control PWM Input Voltage	High_VPDIM	ON	1.3	--	VL	V	VPDIM
	Low_VPDIM	OFF	0	--	0.8	V	
Pull-down resistor	Rpd		100	300	500	kΩ	BLEN,VPDIM
PWM frequency	fPDIM		100	500	1000	Hz	VPDIM
Dimming Rate (PWM Duty)	DR	VL=12.0V	5	--	100	%	VPDIM
Estimated Life of LED Note	LL	PWM duty=100%	--	(70,000)	--	hrs	

- Note:
- The lifetime of the LED is defined as a period till the brightness of the LED decreases to the half of its initial value.
 - This figure is given as a reference purpose only, and not as a guarantee.
 - This figure is estimated for an LED operating alone.
As the performance of an LED may differ when assembled as a monitor.
 - Estimated lifetime could vary on a different temperature and usually higher temperature could reduce the life significantly.

6.2 LVDS Interface

6.2.1 LVDS DC Characteristics

(Unless otherwise noted, $T_a=25\text{ }^\circ\text{C}$, $V_{CC}=3.3\text{V}$, $GND=0\text{V}$)

Item	Symbol	Condition	Rating			Unit	Applicable terminal
			MIN	TYP	MAX		
Differential input high threshold	Rxvth	$R_{xvcm}=1.2\text{V}$	-	-	0.1	V	CLK+, CLK-, Rx0+, Rx0-, Rx1+, Rx1-, Rx2+, Rx2-, Rx3+, Rx3-
Differential input low threshold	Rxvtl		-0.1	-	-	V	
Differential input Common-mode voltage	Rxvcm		0.6	1.2	$2.4- V_{ID} /2$	V	
Differential input voltage	$ V_{ID} $		0.2	0.4	0.6	V	
Differential input leakage current	R_{VXliz}		-10	-	+10	μA	

Single end signals

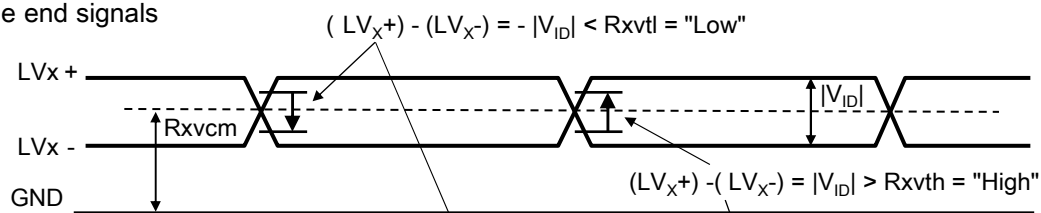

Differential signals

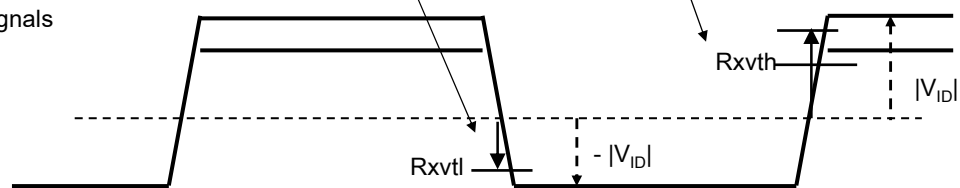

6.2.2 LVDS AC Characteristics

(Unless otherwise noted, Ta=25 °C,VCC=3.3V,GND=0V)

Item	Symbol	Rating			Unit
		MIN	TYP	MAX	
CLK Frequency	f clk	(48.4)	-	(61.5)	MHz
Clock period	Tc	(16.3)	-	(20.7)	ns
1 data bit time	UI	-	1/7	-	Tc
CLK High level Width	T chw	-	4	-	UI
CLK Low level Width	T clw	-	3	-	UI
Position 1	Tpos_1	-0.25	0	0.25	UI
Position 0	Tpos_0	0.75	1	1.25	UI
Position 6	Tpos_6	1.75	2	2.25	UI
Position 5	Tpos_5	2.75	3	3.25	UI
Position 4	Tpos_4	3.75	4	4.25	UI
Position 3	Tpos_3	4.75	5	5.25	UI
Position 2	Tpos_2	5.75	6	6.25	UI
PLL wake-up time	TenPLL	-	-	150	us

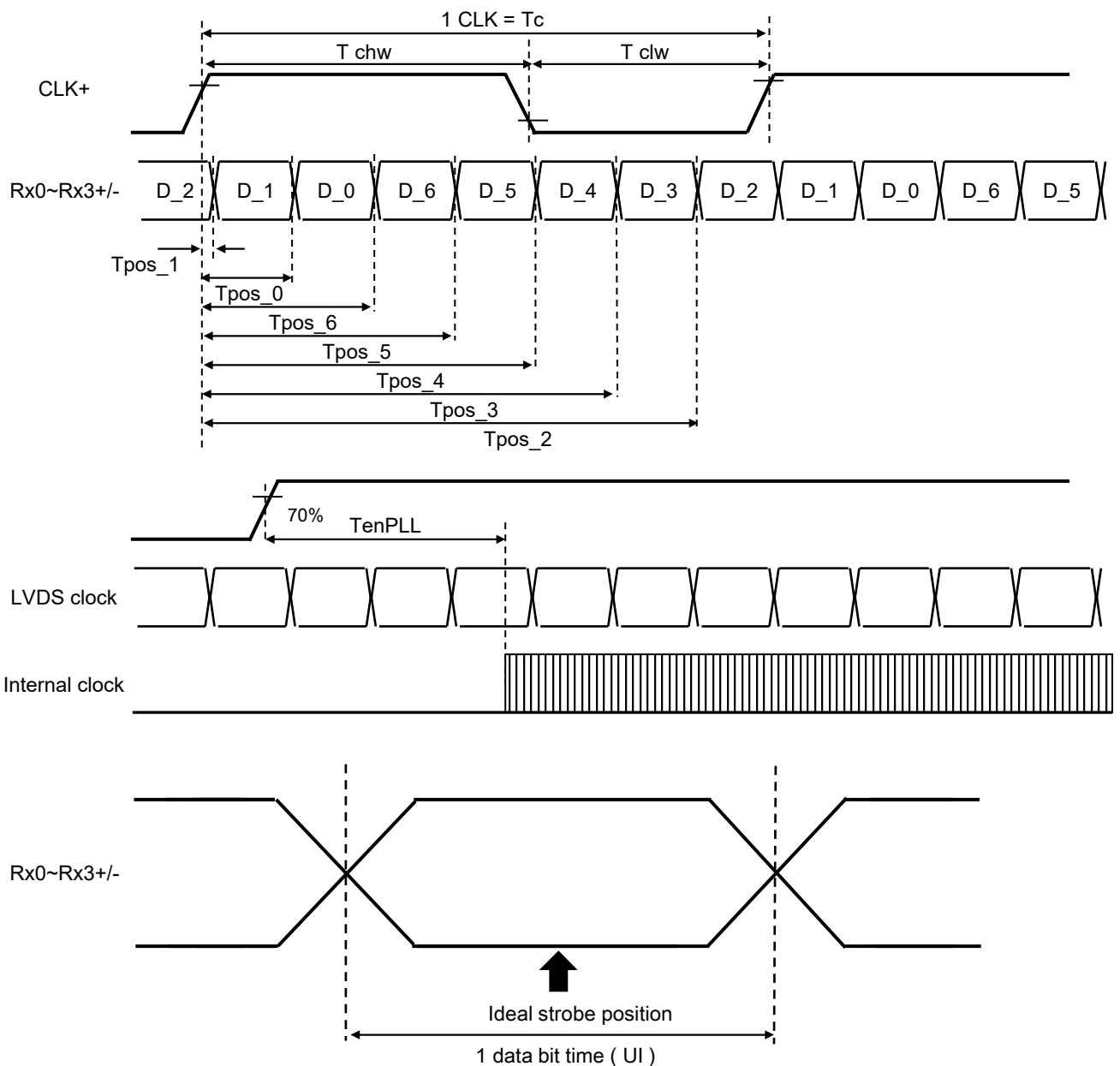

6.2.3 Input Data Format

VESA Format 8bit (MODE = High)

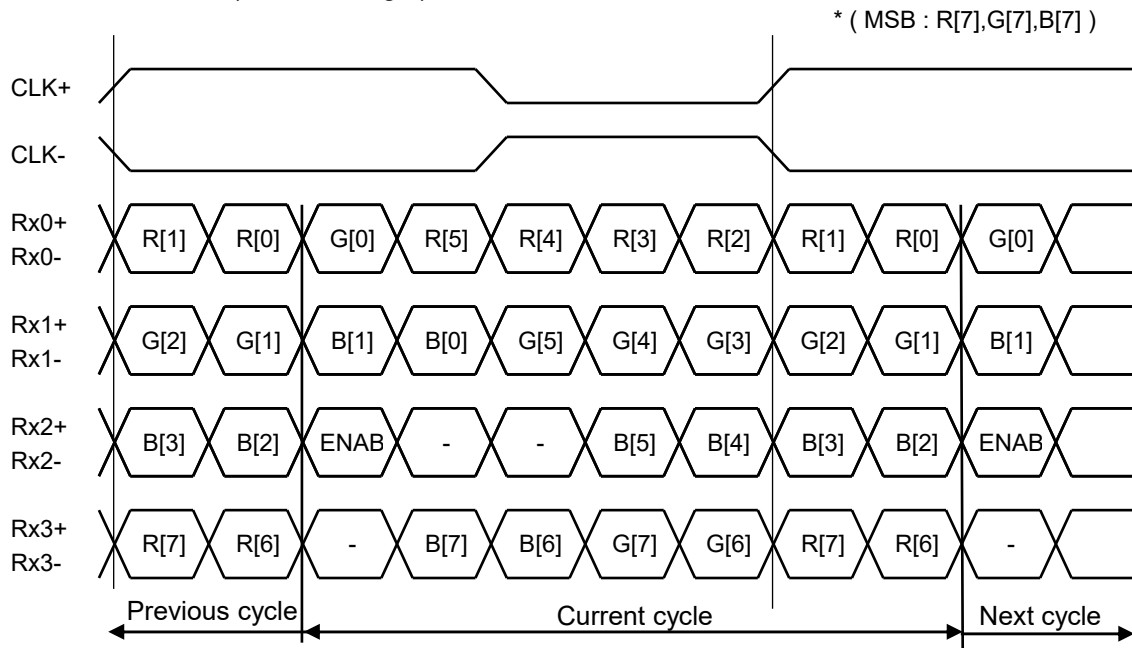

JEIDA Format 8bit (MODE = Low)

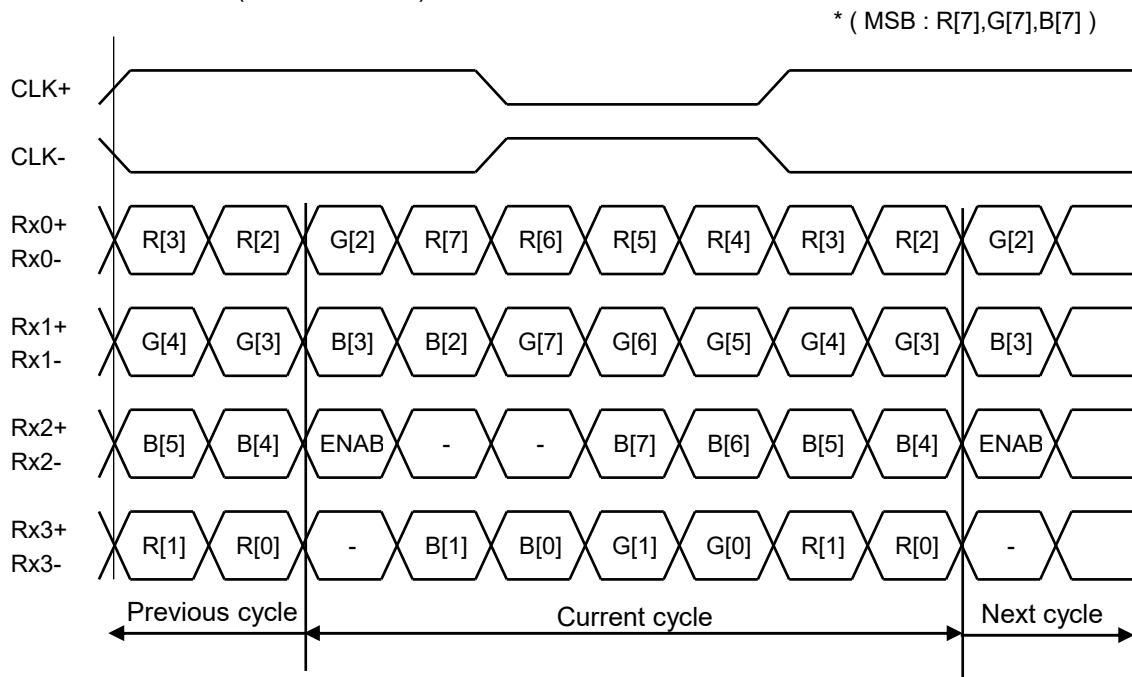

Note) For 6-bits input, MSB : R[7],G[7],B[7] and LSB : R[2],G[2],B[2].

6.3 Input Timing Specifications

Item	Symbol	Rating			Unit	Signal (*)	
		MIN	TYP	MAX			
CLK frequency	fCLK	(48.4)	(52.4)	(61.5)	MHz	CLK	
Vertical	Frequency	fVD	60			Hz	ENAB
	Period	t _v	(773)	(808)	(851)	H	R[7:0],G[7:0],B[7:0]
	Blanking Time	t _{vb}	(5)	(40)	(83)	H	
	Active Time	t _{vdp}	768			H	
Horizontal	Frequency	fHD	(48.5)			kHz	CLK,ENAB
	Period	t _h	(1044)	(1080)	(1204)	CLK	R[7:0],G[7:0],B[7:0]
	Blanking Time	t _{hb}	(20)	(56)	(180)	CLK	
	ENAB pulse width	t _{enp}	1024			CLK	
	Active Time	t _{hdp}	1024			CLK	

(*) Input terminals are (Rx0 +/-, Rx1 +/-, Rx2 +/-, Rx3 +/-, CLK +/-).

<Vertical timing>

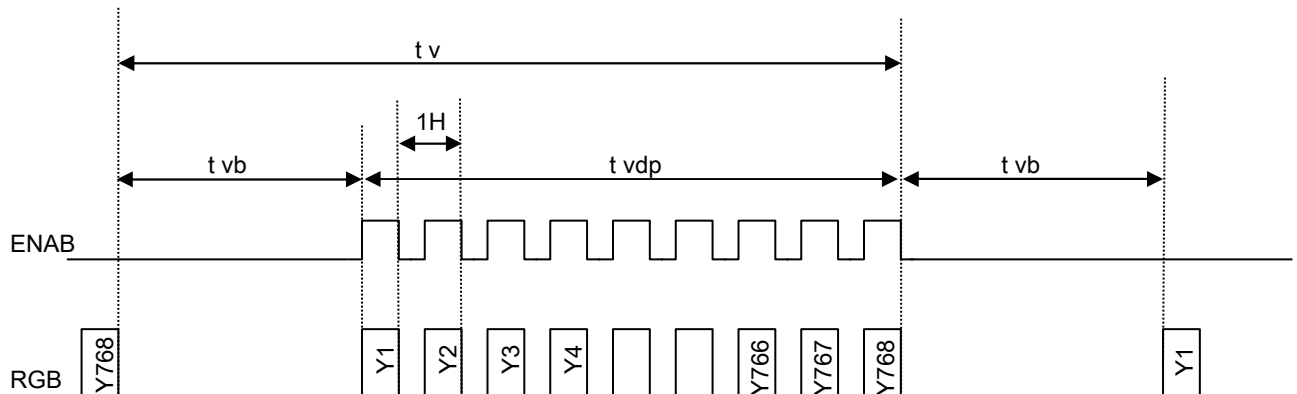

<Horizontal timing>

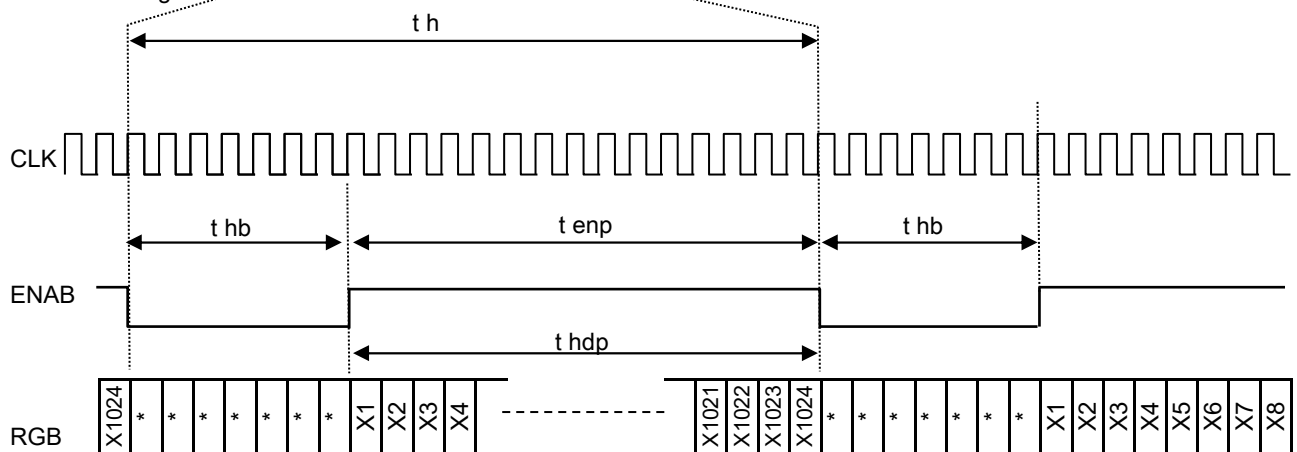

6.4 Power ON/OFF Sequence

[LCD]

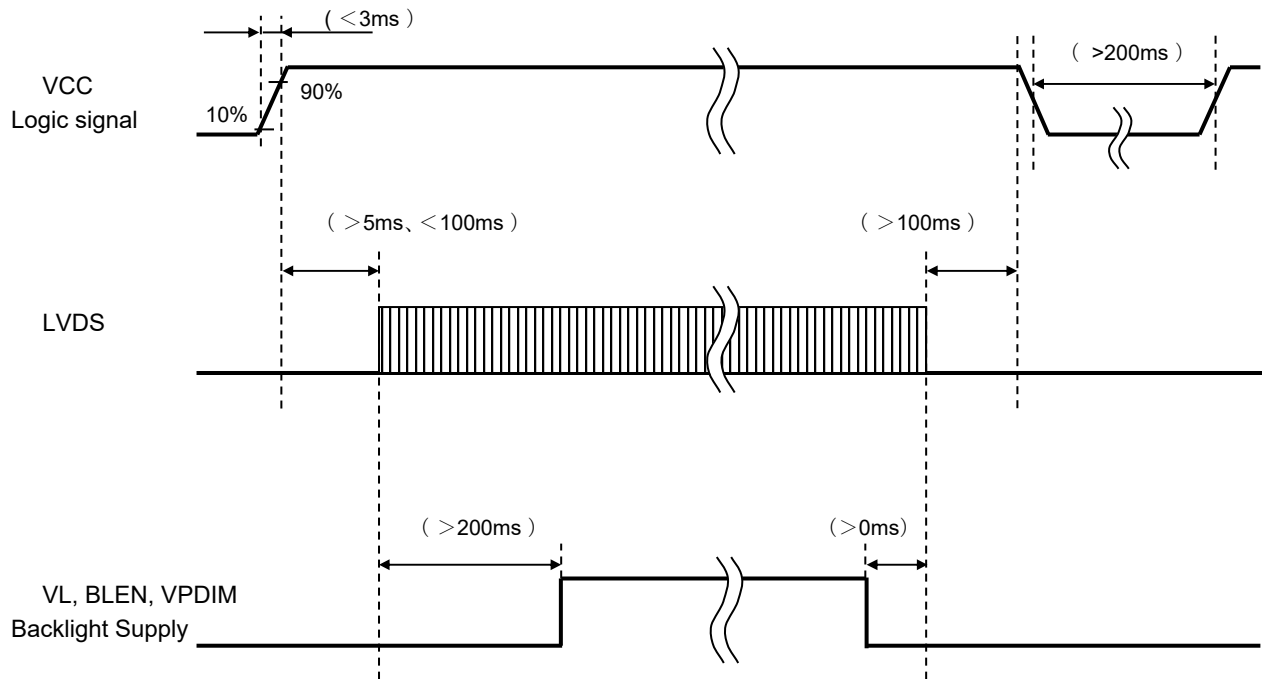

7. Characteristics

7.1 Optical Characteristics

(Measurement Condition)

Measuring instruments: CS2000 (KONICA MINOLTA), LCD7200 (OTSUKA ELECTRONICS), EZcontrastXL88 (ELDIM)

Driving condition: VCC=3.3V, GND=0V, Optimized VCOMDC

Backlight: ILPWM duty=100%

Measured temperature: Ta = 25°C

Item		Symbol	Condition	MIN	TYP	MAX	Unit	Note №	Remark
Response time	Rise time	TON	[Data]= 00h← → FFh	-	-	(40)	ms	1	
	+ Fall time	TOFF							
Contrast ratio		CR	[Data]= FFh / 00h	(650)	(1200)	-		2	
Viewing angle	Left	θL	[Data]= FFh / 00h CR ≥ (10)	-	(88)	-	deg	3	
	Right	θR		-	(88)	-	deg		
	Up	φU		-	(88)	-	deg		
	Down	φD		-	(88)	-	deg		
White Chromaticity		x y	[Data]= FFh	White chromaticity range				4	
Center Brightness			[Data]= FFh	(630)	(900)	-	cd/m ²	5	
Brightness distribution			[Data]= FFh	(70)	-	-	%	6	

* Note number 1 to 6: Refer to the APPENDIX of "Reference Method for Measuring Optical Characteristics and Performance".

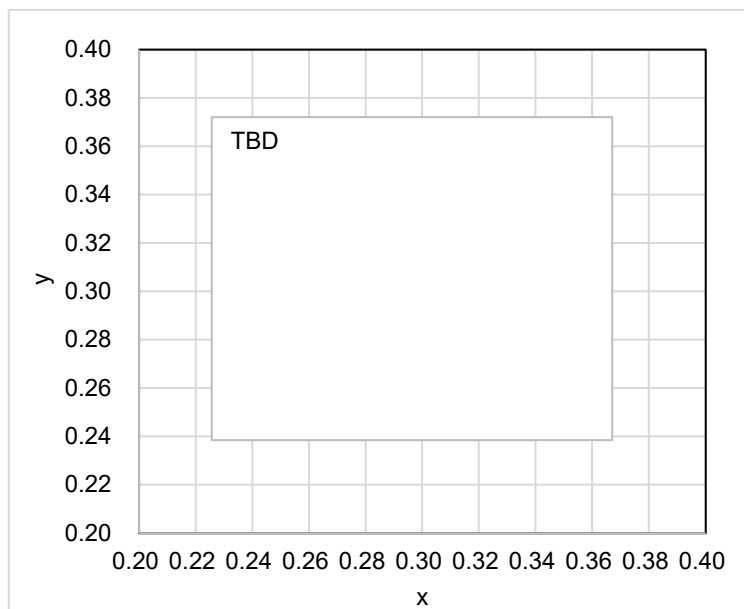

White Chromaticity Range

(White Chromaticity Range)

x	y
(TBD)	(TBD)
(TBD)	(TBD)
(TBD)	(TBD)
(TBD)	(TBD)
(TBD)	(TBD)
(TBD)	(TBD)
(TBD)	(TBD)
(TBD)	(TBD)
(TBD)	(TBD)

8. Criteria of Judgment

8.1 Defective Display and Screen Quality

Test Condition: Observed TFT-LCD monitor from front during operation with the following conditions

Driving Signal: Raster Patter (RGB, white, black)

Signal condition: [Data]:00h, (A8)h, FFh (3steps)

Observation distance: 30 cm

Illuminance: 200 to 350 lx

Backlight: PWM duty=100%

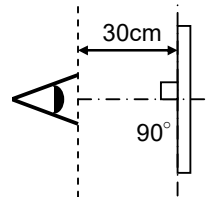

Defect item	Defect content	Criteria	
Display Quality	Line defect	Black, white or color line, 3 or more neighboring defective dots	Not exists
	Dot defect	Uneven brightness on dot-by-dot base due to defective TFT or CF, or dust is counted as dot defect (brighter dot, darker dot) Bright dot: Visible through 1% ND filter at [Data]=00h Dark dot: Appear dark through white display at [Data]=(A8)h	Refer to table 1
		Invisible through 1% ND filter at [Data]=00h	Acceptable
Screen Quality	Stain	Uneven brightness (white stain, black stain etc)	Invisible through 1% ND filter.
	Foreign particle	TBD	
	Others		Use boundary sample for judgment when necessary

φ(mm): Average diameter = (major axis + minor axis)/2
Permissible number: N

Table1

Area	bright dot	Dark dot	Total
A	0	2	2
B	0	3	3
Total	0	4	4

<Landscape model>

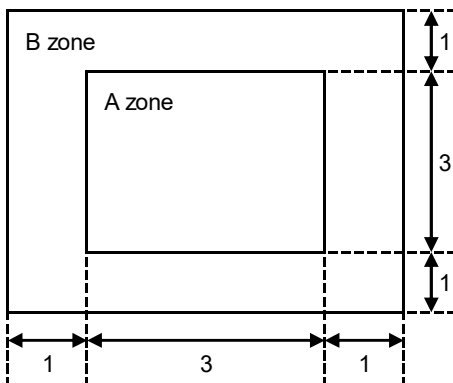

Division of A and B areas

B area: Active area

Dimensional ratio between A and B areas: 1: 3: 1

(Refer to the left figure)

8.2 Screen and Other Appearance

Testing conditions

Observation distance: 30 cm

Illuminance: 1200 ~ 2000 lx

Item		Criteria	Remark
Polarizer	Flaw	Ignore invisible defect when the backlight is on.	Applicable area: Active area only (Refer to the section 3.2 Outward Form)
	Stain		
	Dirt		
	Bubble		
	Dust		
	Dent		
S case		No functional defect occurs	
Connector		No functional defect occurs	

9. Reliability Test

Test item		Test condition	number of failures / number of examinations
Durability test	High temperature storage	Ta = 80°C 240hrs	TBD
	Low temperature storage	Ta = -30°C 240hrs	TBD
	High temperature & high humidity storage	Ta = 60°C, RH = 90%, non condensing ※	TBD
	High temperature operation	Tp = 70°C 240hrs	TBD
	Low temperature operation	Tp = -30°C 240hrs	TBD
	High temperature & high humidity operation	Tp = 40°C, RH = 90%, non condensing ※	TBD
	Thermal shock storage	-30°C ↔ 80°C (30min / 30min) 100cycles	TBD
Mechanical environmental test	Electrostatic discharge test (Non operation)	Confirms to EIAJ ED-4701/300, C=200pF,R=0Ω,V=±200V Each 3 times of discharge on and power supply and other terminals.	TBD
	Surface discharge test (Non operation)	C=250pF, R=100Ω, V=±(TBD)kV Each 5 times of discharge in both polarities on the center of screen with the case grounded.	TBD
	Vibration test	Total amplitude 1.5mm, f=10~55Hz, X,Y,Z directions for each 2 hours	TBD
	Impact test	Use TOPPAN original jig (see next page) and make an impact with peak acceleration of 1000m/s ² for 6 msec with half sine-curve at 3 times to each X, Y, Z directions in conformance with JIS C 60068-2-27-2011.	TBD
Packing test	Packing vibration-proof test	Acceleration of 19.6m/s ² with frequency of 10→55→10Hz, X,Y, Zdirection for each 30 minutes.	TBD
	Packing drop test	Drop from 75cm high. 1 time to each 6 surfaces, 3 edges, 1 corner	TBD

Note: Ta=ambient temperature Tp=Panel temperature

※ The profile of high temperature/humidity storage and High Temperature/humidity operation
(Pure water of over 10MΩ·cm shall be used.)

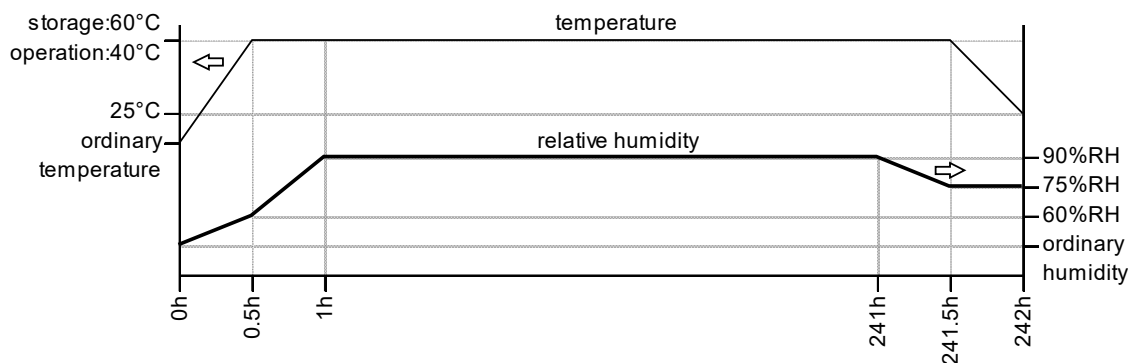
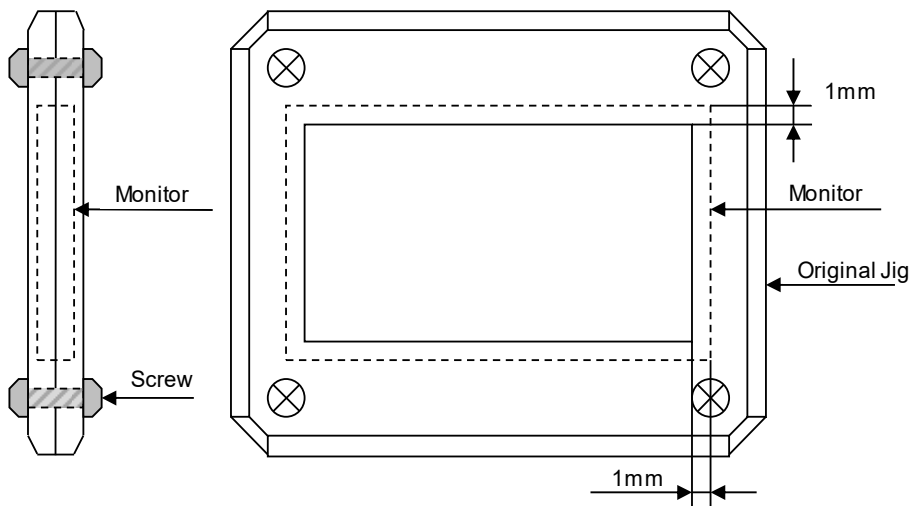

Table2. Reliability Criteria

The parameters should be measured after leaving the monitor at the ordinary temperature for 24 hours
or more after the test completion.

Item	Standard	Remark
Display quality	No visible abnormality shall be seen. (Except for unevenness by Pol deterioration.)	
Contrast ratio	200 or more	Backlight ON

TOPPAN Original Jig



10. Packing Specifications

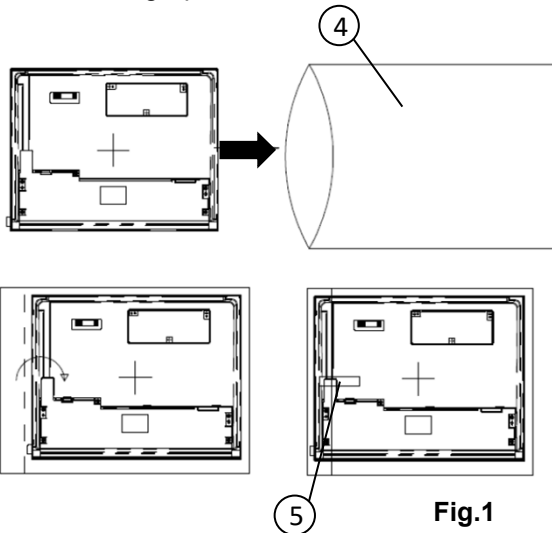

【Step1】 · Each product is to be inserted into the bag.
(Fig.1)

【Step2】 · Two cushions are to be insert into outer carton.
(Fig.2)

【Step3】 · Each product is to be inserted into slit of the cushion.
· 20pcs
(Fig.3)

【Step4】 · Cushion T is to be inserted into outer carton.
(Fig.4)

【Step5】 · The outer carton is to be sealed in H-shape with packing tape.
(Fig.5)

【Step6】 · The model number, quantity of products,
and shipping date are to be printed on the outer carton.
· If necessary, shipping labels or impression markings
are to be put on the outer carton.

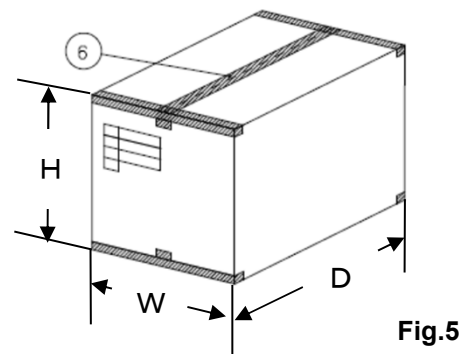
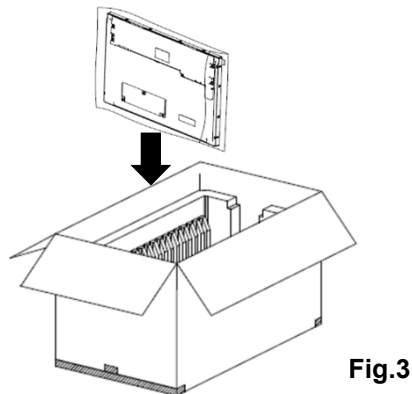
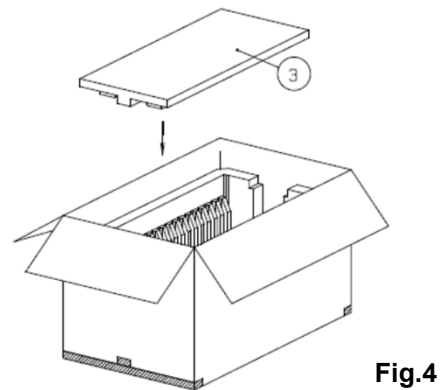
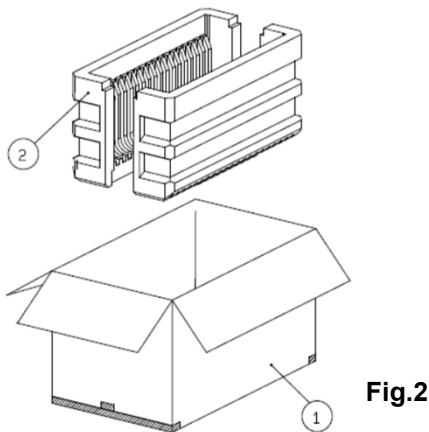

Remark: The return of packing materials is not required.

	Packing item name	Specs, Material
①	Outer carton	Corrugated cardboard
②	Cushion S	Polypropylene
③	Cushion T	Polypropylene
④	Product's bag	
⑤	Tape	
⑥	Tape	

Dimension of outer carton	
D : Approx.	(645 mm)
W : Approx.	(358 mm)
H : Approx.	(344 mm)
Quality of products packed in one carton :	20 pcs
Gross weight : Approx.	12.7 kg

11. Handling Instruction

11.1 Cautions for Handling LCD panels



Caution

- (1) Do not make an impact on the LCD panel glass because it may break and you may get injured from it.
- (2) If the glass breaks, do not touch it with bare hands.
(Fragment of broken glass may stick you or you cut yourself on it.)
- (3) If you get injured, receive adequate first aid and consult a medial doctor.
- (4) Do not let liquid crystal get into your mouth.
(If the LCD panel glass breaks, try not let liquid crystal get into your mouth even toxic property of liquid crystal has not been confirmed.)
- (5) If liquid crystal adheres, rinse it out thoroughly.
(If liquid crystal adheres to your cloth or skin, wipe it off with rubbing alcohol or wash it thoroughly with soap. If liquid crystal gets into eyes, rinse it with clean water for at least 15 minutes and consult an eye doctor.

If you scrap this products, follow a disposal standard of industrial waste

- (6) that is legally valid in the community, country or territory where you reside.
- (7) Do not connect or disconnect this product while its application products is powered on.
- (8) Do not attempt to disassemble or modify this product as it is precision component.
- (9) If a part of soldering part has been exposed, and avoid contact (short-circuit) with a metallic part of the case etc. about Circuit board of this model, please.
Please insulate it with the insulating tape etc. if necessary.
The defective operation is caused, and there is a possibility to generation of heat and the ignition.
- (10) For protection your circuit, we recommend you to add excess current protection circuit to power supply.

Caution



This mark is used to indicate a precaution or an instruction which, if not correctly observed, may result in bodily injury, or material damages alone.

11.2 Precautions for Handling

- 1) Wear finger tips at incoming inspection and for handling the TFT monitors to keep display quality and keep the working area clean.
Do not touch the surface of the monitor as it is easily scratched.
- 2) Wear grounded wrist-straps and use electrostatic neutralization blowers to prevent static charge and discharge when handling the TFT monitors as the LED in this TFT monitors is damageable to electrostatic discharge.
Designate an appropriate operating area, and set equipment, tools, and machines properly when handling this product.
- 3) Avoid strong mechanical shock including knocking, hitting or dropping to the TFT monitors for protecting their glass parts.
Do not use the TFT monitors that have been experienced dropping or strong mechanical shock.
- 4) Do not use or storage the TFT monitors at high temperature and high humidity environment.
Particularly, never use or storage the TFT monitors at a location where condensation builds up.
- 5) Avoid using and storing TFT monitors at a location where they are exposed to direct sunlight or ultraviolet rays to prevent the LCD panels from deterioration by ultraviolet rays.
- 6) Do not stain or damage the contacts of the Connector
Corresponding connector needs to be inserted until it can reach to the end of connector slot.
During insertion, make sure to keep the cable in a horizontal position to avoid an oblique insertion.
Otherwise, it may cause poor contact or deteriorate reliability of the Connector.
- 7) Peel off the protective film on the TFT monitors during mounting process.
Refer to the section 11.5 on how to peel off the protective film.
We are not responsible for electrostatic discharge failures or other defects occur when peeling off the protective film.

11.3 Precautions for Operation

- 1) Since this TFT monitors are not equipped with light shielding for the driver IC,
do not expose the driver IC to strong lights during operation as it may cause functional failures.
- 2) In case of powering up or powering off this LCD module,
be sure to comply the sequence as instructed in this specification.
- 3) Do not plug in or out the Connector while power supply is switch on.
Plug the Connector in and out while power supply is switched off.
- 4) Do not operate the TFT monitors in the strong magnetic field. It may break the TFT monitors.
- 5) Do not display a fixed image on the screen for a long time.
Use a screen-saver or other measures to avoid a fixed image displayed on the screen for a long time.
Otherwise, it may cause burn-in image on the screen due the characteristics of liquid crystal.

11.4 Storage Condition for Shipping Cartons

(Storage environment)

- Temperature 0 to 40° C
- Humidity 60%RH or less
No-condensing occurs under low temperature with high humidity condition.
- Atmosphere No poisonous gas that can erode electronic components and/or wiring materials should be detected.
- Time period 1 year
- Unpacking To prevent damages caused by static electricity, anti-static precautionary measures (e.g. earthing, anti-static mat) should be implemented.
After unpack, keep product in the appropriate condition, otherwise bubble seal of Protective film may be printed on Polarizer.
- Maximum piling up 4 cartons (excluding the bottom)

*Conditions to storage after unpacking

(Storage environment)

- Temperature 0 to 40° C
- Humidity 60%RH or less
No-condensing occurs under low temperature with high humidity condition.
- Atmosphere No poisonous gas that can erode electronic components and/or wiring materials should be detected.
- Time period 1 year (Shelf life)
- Others Keep/ store away from direct sunlight
Storage goods on original tray made by TOPPAN.

11.5 Precautions for Peeling off the Protective film

The followings work environment and work method are recommended to prevent the TFT monitors from static damage or adhesion of dust when peeling off the protective films.

A) Work Environment

- a) Humidity: 50 to 70 %RH, Temperature 15 to 27° C
- b) Operators should wear conductive shoes, conductive clothes, conductive finger tips and grounded wrist-straps.
Use an electrostatic neutralization blower.
- c) Anti-static treatment should be implemented to work area's floor.
Use a room shielded against outside dust with sticky floor mat laid at the entrance to eliminate dirt.

B) Work Method

The following procedures should taken to prevent the driver ICs from charging and discharging.

- a) Use an electrostatic neutralization blower to blow air on the TFT monitors to its lower right when Tab of Protection Film is placed at the lower right.
Optimize direction of the blowing air and the distance between the TFT monitors and the electrostatic neutralization blower.
- b) Peel off the Tab slowly (spending more than 2 secs to complete)
by pulling it to opposite direction.

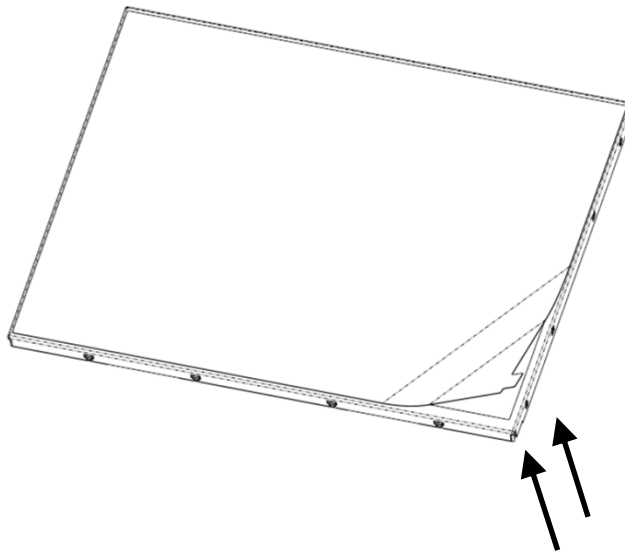

Blower wind direction
(Set an ion blower with its adequate conditions.)

11.6 Warranty

TOPPAN is only liable to defective goods which is stored and used under the condition complying with this specifications and returned within 1 (one) year.

Warranty caused by manufacturing defect shall be conducted by replacement of goods or refundment at unit price.

APPENDIX

Reference Method for Measuring Optical Characteristics and Performance

1. Measurement Condition (Backlight ON)

Measuring instruments: CS2000 (KONICA MINOLTA), LCD7200 (OTSUKA ELECTRONICS), EZcontrastXL88 (ELDIM)

Driving condition: Refer to the section "Optical Characteristics"

Measured temperature: 25°C unless specified

Measurement system: See the chart below. The luminance meter is placed on the normal line of measurement system.

Measurement point: At the center of the screen unless otherwise specified

Dark box at constant temperature

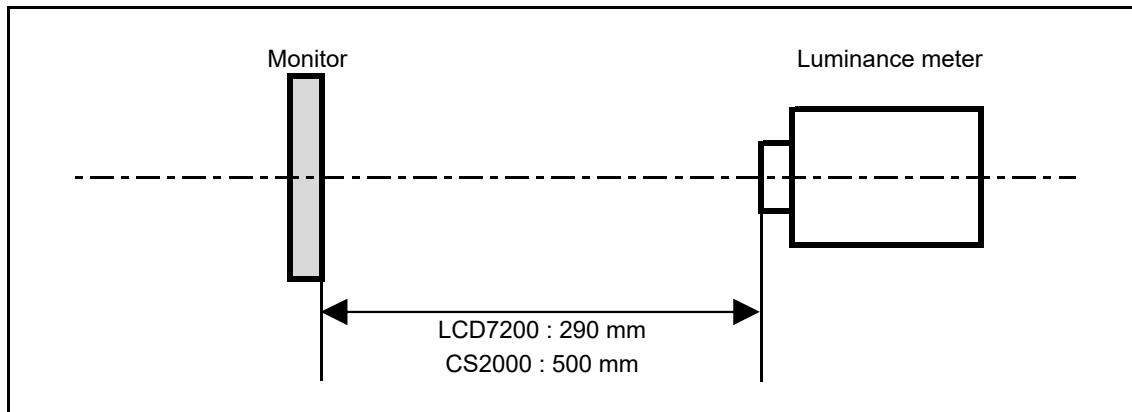

*Measurement is made after 30 minutes of lighting of the backlight.

Measurement point: At the center point of the screen

Brightness distribution: 9 points shown in the following drawing.

<Landscape model>

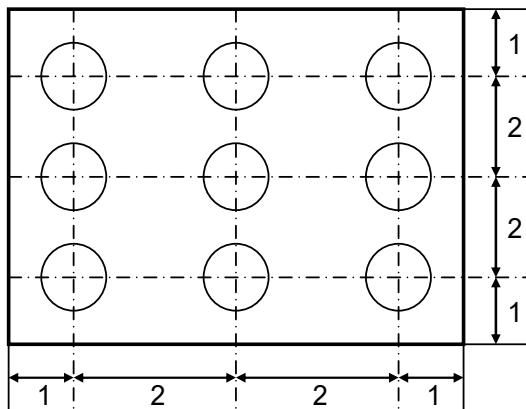

Dimensional ratio of active area

Backlight PWM duty=100%

2. Test Method

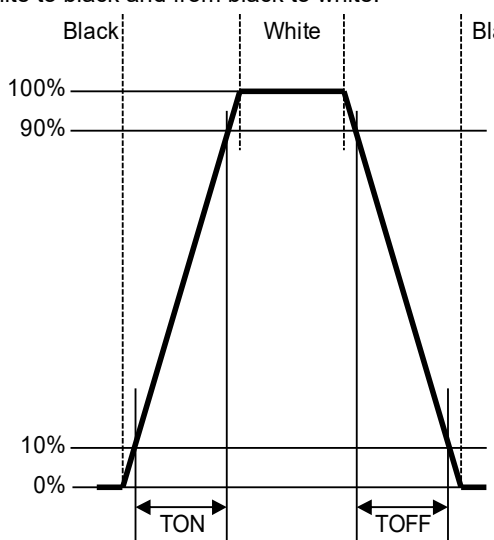
Notice	Item	Test method	Measuring instrument	Remark
1	Response time	Measure output signal waveform by the luminance meter when raster of window pattern is changed from white to black and from black to white. 	LCD7200	Black display [Data]=00h White display [Data]=FFh TON Rise time TOFF Fall time
2	Contrast ratio	Measure maximum luminance Y1([Data]=FFh) and minimum luminance Y2([Data]=00h) at the center of the screen by displaying raster or window pattern. Then calculate the ratio between these two values. $\text{Contrast ratio} = Y1/Y2$ Diameter of measuring point: 7.8mmφ(CS2000)	CS2000	
3	Viewing angle Horizontalθ Verticalφ	Move the luminance meter from right to left and up and down and determine the angles where contrast ratio is (10).	EZcontrastXL88	
4	White chromaticity	Measure chromaticity coordinates x and y of CIE1931 colorimetric system at [Data] = FFh Color matching function: 2°view measurement angle: 1°	CS2000	
5	Center brightness	Measure the brightness at the center of the screen.	CS2000	
6	Brightness distribution	$(\text{Brightness distribution}) = 100 \times B/A \%$ A : max. brightness of the 9 points B : min. brightness of the 9 points	CS2000	

DATA MODUL



ALL TECHNOLOGIES. ALL COMPETENCIES. ONE SPECIALIST.

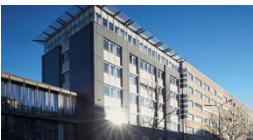

DATA MODUL AG
Landsberger Straße 322
DE-80687 Munich
Phone: +49 89 56017 0

DATA MODUL WEIKERSHEIM GMBH
Lindenstraße 8
DE-97990 Weikersheim
Phone: +49 7934 101 0

