



SPECIFICATION

ORTUSTECH

COM43H4N66ULC

4.3" – 480x800 – Blanview

Version: 2.0

Date: 16.12.2020

Note: This specification is subject to change without prior notice

www.data-modul.com

Specifications for

Blanview TFT-LCD Monitor (4.3" WVGA 480 x RGB x 800 Portrait)

Version 2.0

(Please be sure to check the specifications latest version.)

MODEL COM43H4N66ULC

Customer's Approval

Signature:

Name:

Section:

Title:

Date:

ORTUSTECH

TOPPAN PRINTING CO.,LTD.

Electronics Division

Ortus Subdivision

Approved by

Y. Nakajima

Checked by

S. Kawayama

Prepared by

M. Jojo

Version History

Ver.	Date	Page	Description
1.0	Jul.31,2020	-	- First issue
2.0	Dec.16,2020	P.22	Change 9.1 Power-ON Sequence Command / Parameter
		 P.27	Change 9.6 Refresh Sequence Command / Parameter
	x2		

Contents

1. Application	4
2. Outline Specifications		
2.1 Features of the Product	5
2.2 Display Method	5
3. Dimensions and Shape		
3.1 Dimensions	7
3.2 Outward Form	8
3.3 Serial No. print (S-print)	9
4. Pin Assignment	10
5. Absolute Maximum Rating	11
6. Recommended Operating Conditions	11
7. Characteristics		
7.1 DC Characteristics		
7.1.1 Display Module	12
7.1.2 MIPI DSI Interface	12
7.1.3 Backlight	13
7.2 AC Characteristics		
7.2.1 HS-RX Specifications	14
7.2.2 LP-TX Specifications	14
7.2.3 RX/TX Specifications	15
7.2.4 Reset input timing	17
7.3 Input Timing Characteristics	17
7.4 Input Signal Timing Chart	18
8. About MIPI Interface		
8.1 Version	19
8.2 DSI protocol	19
8.3 Packet data types	20
8.4 Packet Footer on the long packet	20
9. Sequence		
9.1 Power-ON Sequence	21
9.2 Power-OFF Sequence	24
9.3 Sleep Sequence	24
9.4 Sleep Release Sequence	24
9.5 Power ON/OFF timing	25
9.6 Refresh Sequence	26
10. LED Circuit	28
11. Characteristics		
11.1 Optical Characteristics	29
11.2 Temperature Characteristics	30
12. Criteria of Judgment		
12.1 Defective Display and Screen Quality	31
12.2 Screen and Other Appearance	32
13. Reliability Test	33
14. Packing Specifications	35
15. Handling Instruction		
15.1 Cautions for Handling LCD panels	36
15.2 Precautions for Handling	37
15.3 Precautions for Operation	37
15.4 Storage Condition for Shipping Cartons	38
15.5 Precautions for Peeling off the Protective film	39
15.6 Warranty	39
APPENDIX	40

1. Application

This Specification is applicable to 108.5mm (4.3 inch) Blanview TFT-LCD monitor for non-military use.

- ◎ TOPPAN PRINTING makes no warranty or assume no liability that use of this Product and/or any information including drawings in this Specification by Purchaser is not infringing any patent or other intellectual property rights owned by third parties, and TOPPAN PRINTING shall not grant to Purchaser any right to use any patent or other intellectual property rights owned by third parties. Since this Specification contains TOPPAN PRINTING's confidential information and copy right, Purchaser shall use them with high degree of care to prevent any unauthorized use, disclosure, duplication, publication or dissemination of TOPPAN PRINTING's confidential information and copy right.
- ◎ If Purchaser intends to use this Products for an application which requires higher level of reliability and/or safety in functionality and/or accuracy such as transport equipment (aircraft, train, automobile, etc.), disaster-prevention/security equipment or various safety equipment, Purchaser shall consult TOPPAN PRINTING on such use in advance.
- ◎ This Product shall not be used for application which requires extremely higher level of reliability and/or safety such as aerospace equipment, telecommunication equipment for trunk lines, control equipment for nuclear facilities or life-support medical equipment.
- ◎ It must be noted as an mechanical design manner, especial attention in housing design to prevent arcuation/flexure or caused by stress to the LCD module shall be considered.
- ◎ TOPPAN PRINTING assumes no liability for any damage resulting from misuse, abuse, and/or miss-operation of the Product deviating from the operating conditions and precautions described in the Specification.
- ◎ It shall be mutually conferred if nonconforming defect which result from unspecified cause in this specification arises.
- ◎ If any issue arises as to information provided in this Specification or any other information, TOPPAN PRINTING and Purchaser shall discuss them in good faith and seek solution.
- ◎ TOPPAN PRINTING assumes no liability for defects such as electrostatic discharge failure occurred during peeling off the protective film or Purchaser's assembly process.
- ◎ This Product is compatible for RoHS(2.0) directive.

Object substance	Maximum content [ppm]
Cadmium and its compound	100
Hexavalent Chromium Compound	1000
Lead & Lead compound	1000
Mercury & Mercury compound	1000
Polybrominated biphenyl series (PBB series)	1000
Polybrominated biphenyl ether series (PBDE series)	1000
Bis(2-ethylhexyl)phthalate series(DEHP series)	1000
Butyl benzyl phthalate series(BBP series)	1000
Dibutyl phthalate series(DBP series)	1000
Diisobutyl phthalate series(DIBP series)	1000

2. Outline Specifications

2.1 Features of the Product

- 4.3 inch diagonal display, 480 x RGB [H] x 800 [V] dots.
- 24bitRGB (8-8-8 Format) / 16.7 Million colors.
- MIPI DSI as high-speed interface. Video mode only.
- Timing generator [TG], Counter-electrode driving circuitry, Built-in power supply circuit.
- Various display controls and functional selection.
- Long life & High bright white LED back-light.
- Blanview TFT-LCD, improved outdoor readability.

* MIPI : Mobile Industrial Processor Interface , DSI : Display Serial Interface

	Indoor		Outdoor	
	Readability	Power Efficiency (Battery Life)	Readability	Power Efficiency (Battery Life)
Transmissive	Good	Good	Fair	Poor
Transflective	Fair	Poor	Good	Good
Blanview	Good	Good	Good	Good

2.2 Display Method

Items	Specifications	Remarks
Display type	VA 16.7 Million colors. Blanview, Normally black.	
Driving method	a-Si TFT Active matrix. Line-scanning, Non-interlace.	
Dot arrangement	RGB stripe arrangement.	Refer to "Dot arrangement"
Signal input method	MIPI DSI 2-lanes : 2 data lanes and 1 clock lane	
Backlight type	Long life & High bright white LED.	
NTSC ratio	50%	

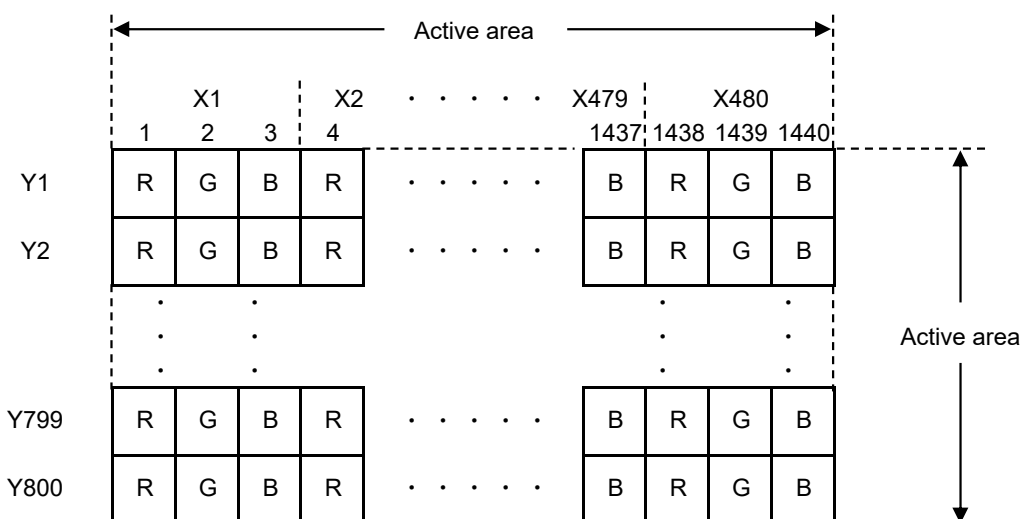

<Features of Blanview>

- Backlight power consumption required to assure visibility. (equivalent to 3.5"QVGA)

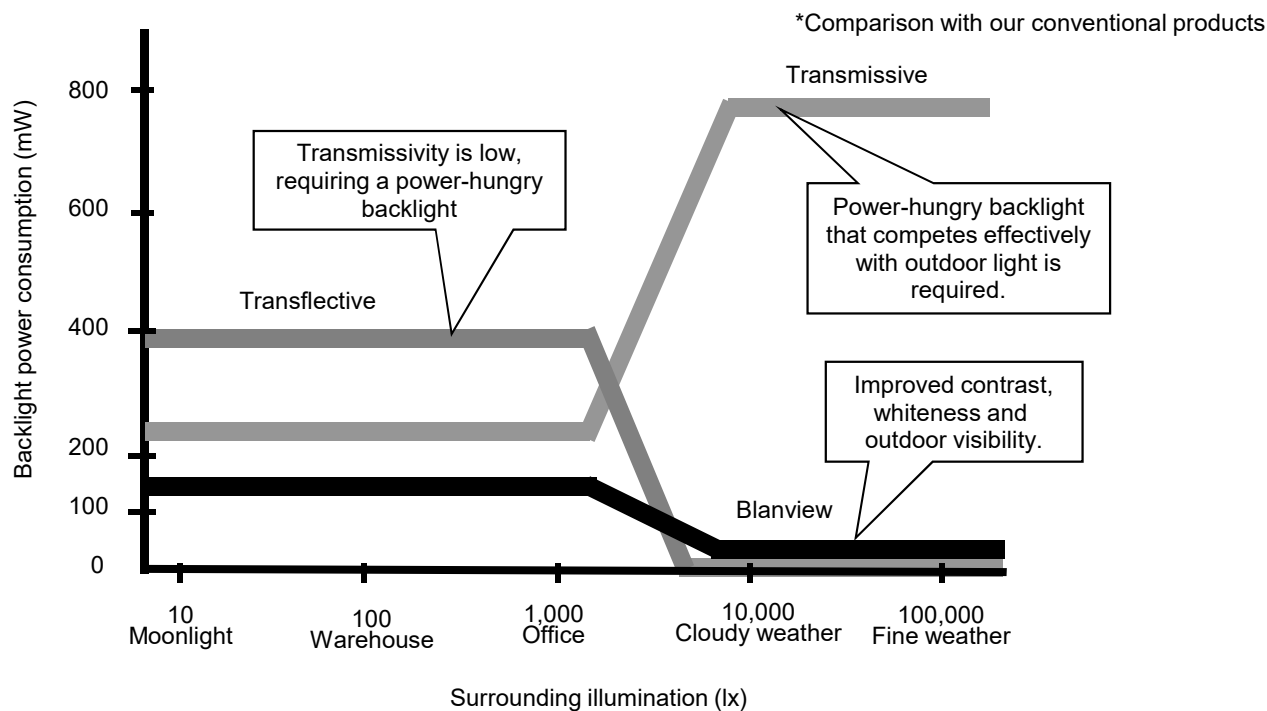

- Contrast characteristics under 100,000lx. (same condition as direct sunlight.)

With better contrast (higher contrast ratio), Blanview TFT-LCD has the best outdoor readability in three different types of TFT-LCD.

Below chart shows contrast value against panel surface brightness. (Horizontal: Panel surface brightness/ Vertical: Contrast value) LCD panel has enough outdoor readability above our Standard line. (TOPPAN PRINTING criteria)

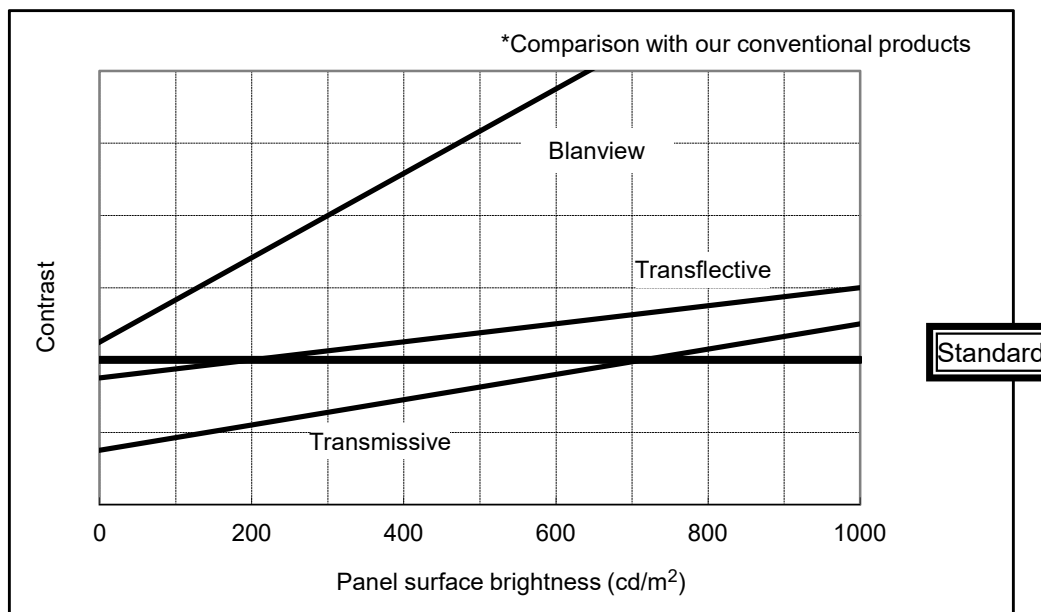

3. Dimensions and Shape

3.1 Dimensions

Items	Specifications	Unit	Remarks
Outline dimensions	61.2 [H] × 103.0 [V] × 1.8 [D]	mm	Exclude FPC cable
Active area	55.8[H] × 93.0[V]	mm	108.5mm diagonal
Number of dots	1440[H] × 800[V]	dot	
Dot pitch	38.75[H] × 116.25[V]	um	
Surface hardness of the polarizer	2	H	Load: 2.94N
Weight	25.2	g	Include FPC cable

3.2 Outward Form

EC No.	REV. No.	REVISE	DATE (Y:M:D)	APPROVED	CHECKED	PREPARED
--------	----------	--------	--------------	----------	---------	----------

(8/42)

20TLM033

Issue: Dec.16,2020

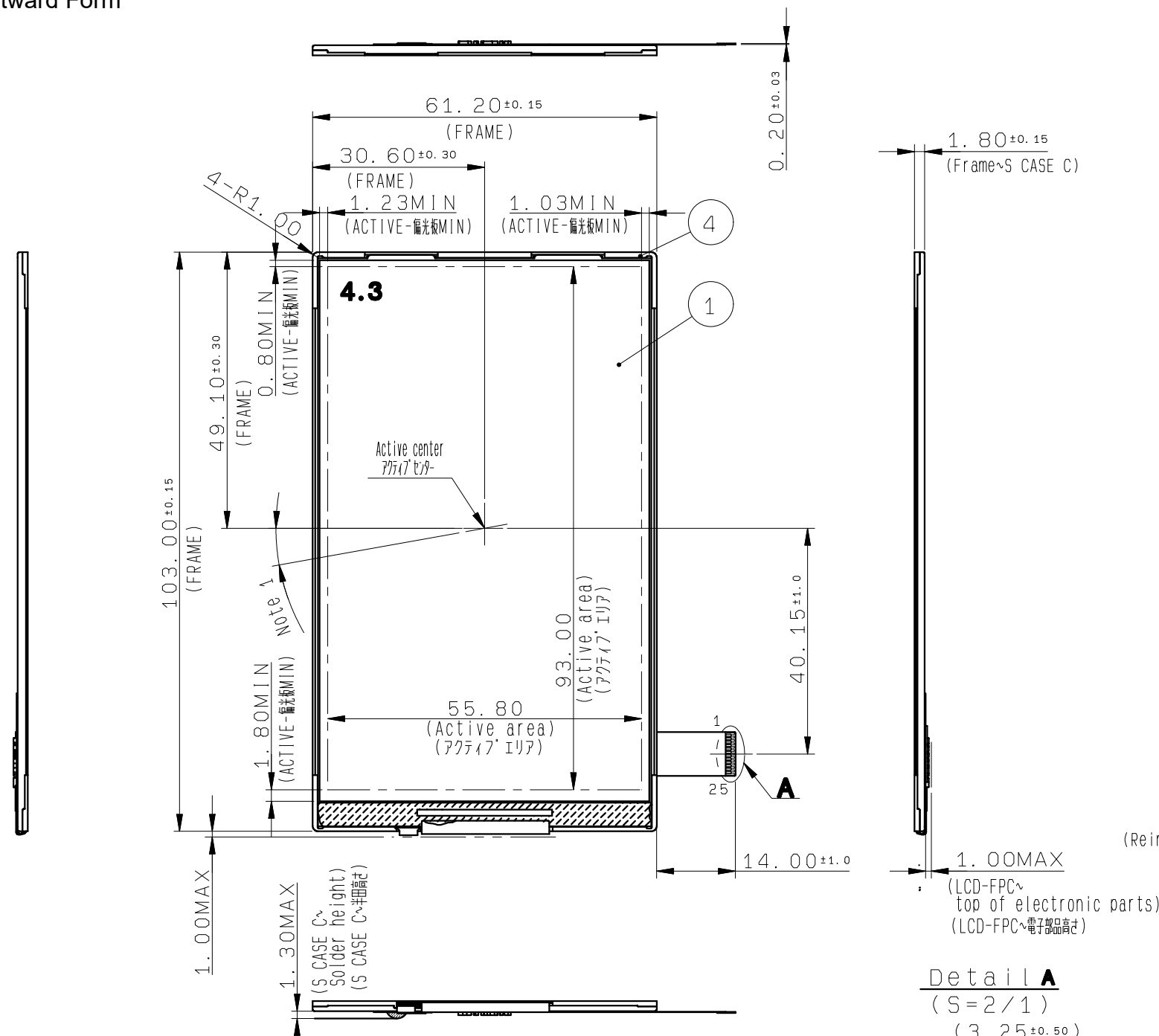

Serial code
(inkjet)
シリアルコード
(インクジェット)

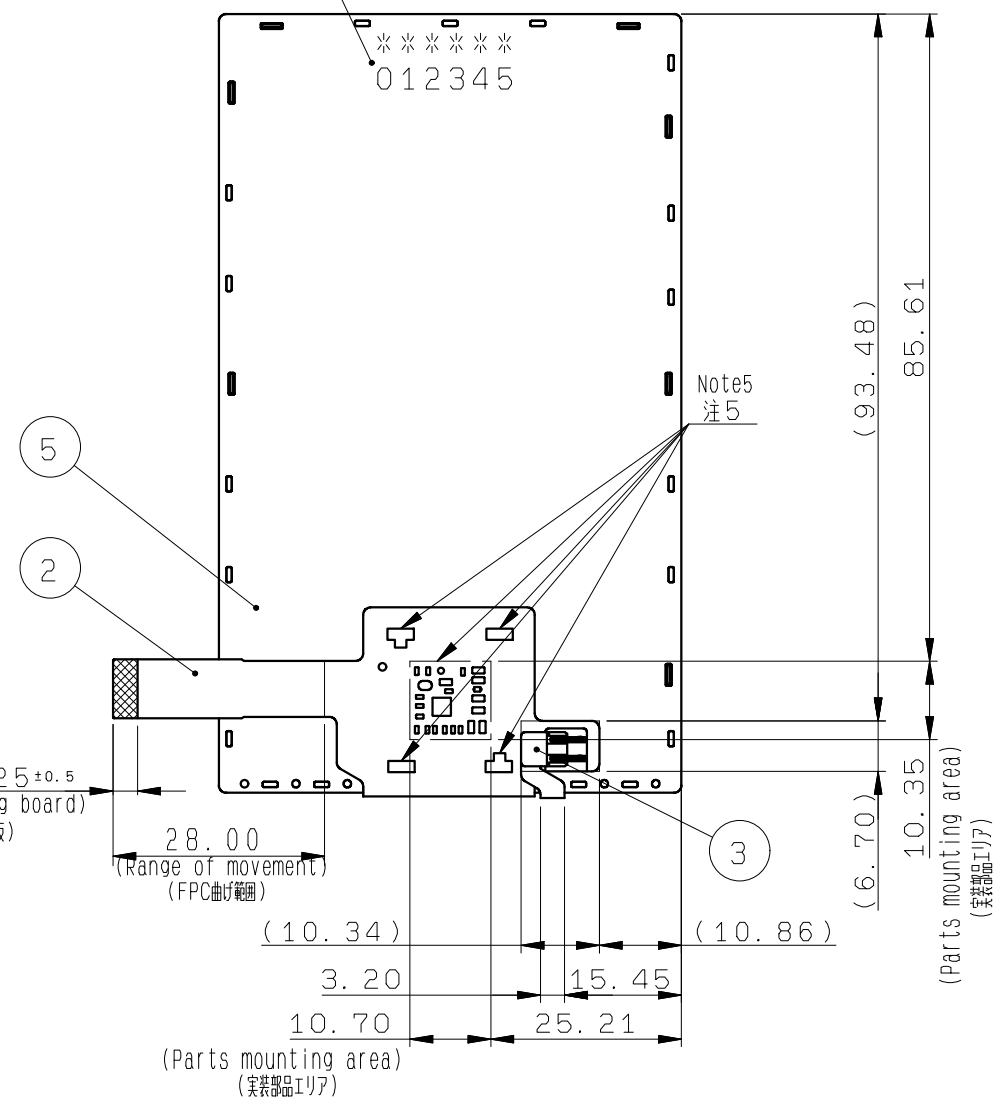

Detail A
(S=2/1)

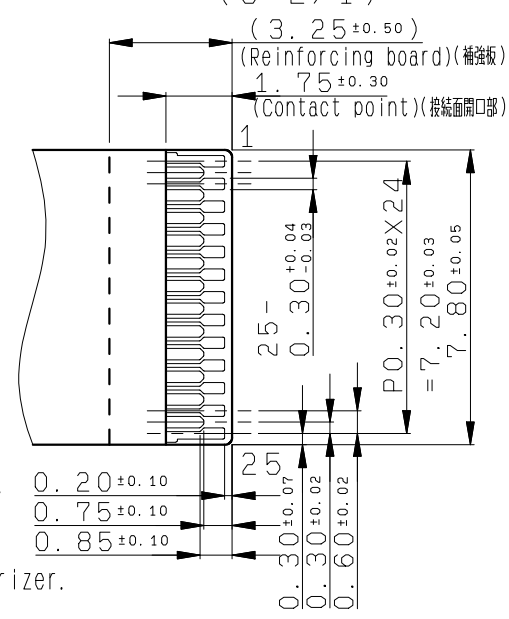

- 注1. LCD PANELの角度スレは、モニター基準軸に対し【±40'】以下とする。
- 2. 保護膜が表面側に貼られます。
表面側保護膜貼付け位置は偏光板に対して【±1.5】とする。
- 3. FPCの推奨コネクタの規格(単品)を下記に示す。
HRS
規格名: FH35C-25S-0.3SHW(50)
- 4. 偏光板の外観仕様につきましては"12. 判定基準"を参照願います。
- 5. 導体開口部は導体部品との接触を避けてください。

- Note 1. Angular deviation of LCD cell from the TFT-LCD monitor's reference axis shall be less than [±40'].
- Note 2. Protective film is affixed on front surface of the screen.
Location tolerance of the protective film shall be ±1.5 mm to the polarizing film.
- Note 3. Recommended FPC connector.
For LCD : HRS, Part number: FH35C-25S-0.3SHW(50)
- Note 4. Refer to "12. CRITERIA OF JUDGMENT" about the appearance specification of a polarizer.
- Note 5. Don't touch any conductive material to conductive area.

	7			
	6			
S CASE C	5		SUS	
FRAME	4		PC	
FPC B	3			used of LED
FPC A	2			used of LCD
TFT-LCD PANEL	1			Glass substrate thickness=0.2t±0.2t
PART NAME	ITEM	PART CODE	MODEL NUMBER	REMARK

APPROVED 尾木	GENERAL TOLERANCE ±0.5	SCALE 1/1	UNIT mm
CHECKED 木下	ISSUE (Y:M:D) 20:07:14	MODEL COM43H4N66U**	
CHECKED	NAME		
DESIGN 梅野聖也			
DRAW 梅野聖也			

TOPPAN TOPPAN PRINTING CO., LTD. DO NOT DUPLICATE, CONFIDENTIAL AND PROPRIETARY			
DRAWING No.	REV.	SHEET	DIV.
RJD600627D301	#	/	

OUTLINE-D4N66

3.3 Serial No. print (S-print)

1) Display Items

S-print indicates the least significant digit of manufacture year (1digit), manufacture month with below alphabet (1letter), model code (5characters), serial number (6digits).

* Contents of Display

*	*	*****	*****
-	-	-----	-----
a	b	c	d

Contents of display				
a	The least significant digit of manufacture year			
b	Manufacture month	Jan-A Feb-B Mar-C Apr-D	May-E Jun-F Jul-G Aug-H	Sep-I Oct-J Nov-K Dec-L
c	Model code	43FTC (Made in Japan) 43FVC (Made in Malaysia)		
d	Serial number			

* Example of indication of Serial No. print (S-print)

•Made in Japan

0L43FTC500125

means "manufactured in December 2020, 4.3" FT type, C specifications, serial number 500125"

•Made in Malaysia

0L43FVC500125

means "manufactured in December 2020, 4.3" FV type, C specifications, serial number 500125"

2) Location of Serial No. print (S-print)

Refer to 3.2 "Outward Form".

3)Others

Please note that it is likely to disappear with an organic solvent about the Serial print.

4. Pin Assignment

No	Symbol	Details	Remark
1	GND	Ground	
2	LED-	Backlight LED Cathode	
3	LED+	Backlight LED Anode	
4	VDD	VDD Power Supply	VDD = 3.3V (TYP)
5	VDD	VDD Power Supply	VDD = 3.3V (TYP)
6	GND	Ground(PVSS)	
7	VCCIO	DSI and I/O Power Supply	VCCIO = 1.8V (TYP)
8	TEST 4	TEST Pim	Please connect to GND.
9	TEST 3	TEST Pim	Please connect to GND.
10	ID1	ID check	Output level is GND.
11	ID2	ID check	Output level is GND.
12	TEST 1	TEST Pim	Please connect to VCCIO(1.8V).
13	TEST 2	TEST Pim	Please connect to VCCIO(1.8V).
14	GND	Ground	
15	RESETB	LCD Reset	L:Initialize Power_ON Reset is Required when Turning on the Power
16	GND	Ground	
17	DSI_D0P	MIPI-DSI Data differential signal input pin	
18	DSI_D0N	MIPI-DSI Data differential signal input pin	
19	GND	Ground	
20	DSI_CN	MIPI-DSI Clock differential signal input pin	
21	DSI_CP	MIPI-DSI Clock differential signal input pin	
22	GND	Ground	
23	DSI_D1P	MIPI-DSI Data differential signal input pin	
24	DSI_D1N	MIPI-DSI Data differential signal input pin	
25	GND	Ground	

-

- Recommended connector: HIROSE : FH35C-25S-0.3SHW(50)

Please make sure to check a consistency between pin assignment in "3.2 Outward Form" and your connector pin assignment when designing your circuit.

- Inconsistency in input signal assignment may cause a malfunction.

Since FPC cable has gold plated terminals, gilt finish contact shoe connector is recommended.

5. Absolute Maximum Rating

GND=0V

Item	Symbol	Condition	Rating		Unit	Applicable terminal
			MIN	MAX		
Supply voltage	VDD	Ta=25 °C	-0.3	4.6	V	VDD
DSI and I/O Power Supply voltage	VCCIO		-0.3	4.6	V	VCCIO
Input voltage for logic	VI		-0.3	VCCIO+0.3	V	RESETB TEST1-4
DSI Input voltage	VDSIIN		-0.15	1.45	V	DSI_D0P/N , DSI_D1P/N DSI_CP/N
LED forward current	IL	Ta=25 °C	-	35	mA	LED+ - LED-
		Ta=70 °C	-	15		
Storage temperature range	Tstg		-30	80	°C	
Storage humidity range	Hstg	Non condensing in an environmental moisture at or less than 40 °C 90%RH.				

6. Recommended Operating Conditions

GND=0V

Item	Symbol	Condition	Rating			Unit	Applicable terminal
			MIN	TYP	MAX		
Supply voltage	VDD		2.7	3.3	3.6	V	VDD
DSI and I/O Power Supply voltage	VCCIO		1.7	1.8	1.9	V	VCCIO
Input voltage for logic	VI		0	-	VCCIO	V	RESETB TEST1-4
DSI Input voltage	VI		-0.05	-	1.35	V	DSI_D0P/N DSI_D1P/N DSI_CP/N
Operational temperature range	Top	Note1,2	-20	25	70	°C	Panel surface temperature
Operating humidity range	Hop	Ta ≤ 40 °C	20	-	85	%	
		Ta > 40 °C	Non condensing in an environmental moisture at or less than 40 °C 85%RH.				

Note1: This monitor is operatable in this temperature range. With regard to optical characteristics, refer to Item 11."CHARACTERISTICS".

Note 2: Acceptable Forward Current to LED is up to 15 mA, when Ta=+70 °C.
Do not exceed Allowable Forward Current shown on the chart below.

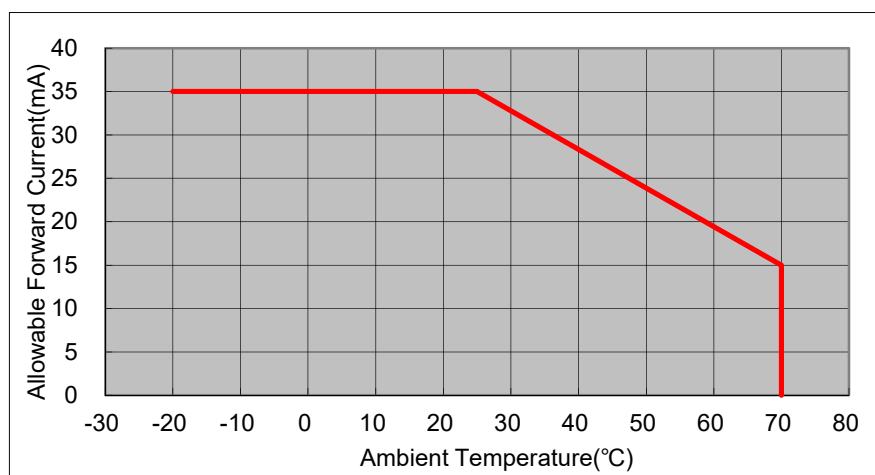

7. Characteristics

7.1 DC Characteristics

7.1.1 Display Module

(Unless otherwise noted, Ta=25 °C, VDD=3.3V, VCCIO=1.8V, GND=0V)

Item	Symbol	Condition	Rating			Unit	Applicable terminal
			MIN	TYP	MAX		
Input Signal Voltage	VIH	VCCIO=1.7-1.9V	0.7×VCCIO	-	VCCIO	V	RESETB
	VIL		0	-	0.3×VCCIO	V	TEST1-4
Operating Current	IDD	fDSICLK=150 MHz	-	12.5	25.0	mA	VDD
	ICCIO	Color bar display	-	3.3	6.6	mA	VCCIO
Sleep_mode Current	IDDS	Clock/Data=LP11	-	43	100	uA	VDD
	ICCIOS	Sleep_mode	-	10	100	uA	VCCIO

7.1.2 MIPI DSI Interface

Item	Symbol	Condition	Rating			Unit	Note
			MIN	TYP	MAX		
HS-RX	Differential input high threshold	VIDTH	-	-	110	mV	
	Differential input low threshold	VIDTL	-110	-	-	mV	
	Single-ended input high voltage	VIHHS	-	-	460	mV	
	Single-ended input low voltage	VILHS	-40	-	-	mV	
	Common-mode voltage HS receive mode	VCMRXD C	70	-	330	mV	
	Differential input impedance	ZID	80	100	125	Ohm	
LP-RX	Logic 1 input voltage	VIH	880	-	-	mV	
	Logic 0 input voltage	VIL	-	-	550	mV	
LP-TX	Thevenin output low level	VOL	-50	-	50	mV	
	Thevenin output high level	VOH	1.1	1.2	1.3	V	
	Output impedance of LP transmitter	ZOLP	110	-	-	Ohm	
CD-RX	Logic 1 contention threshold	VIHCD	450	-	-	mV	
	Logic 0 contention threshold	VILCD	-	-	220	mV	

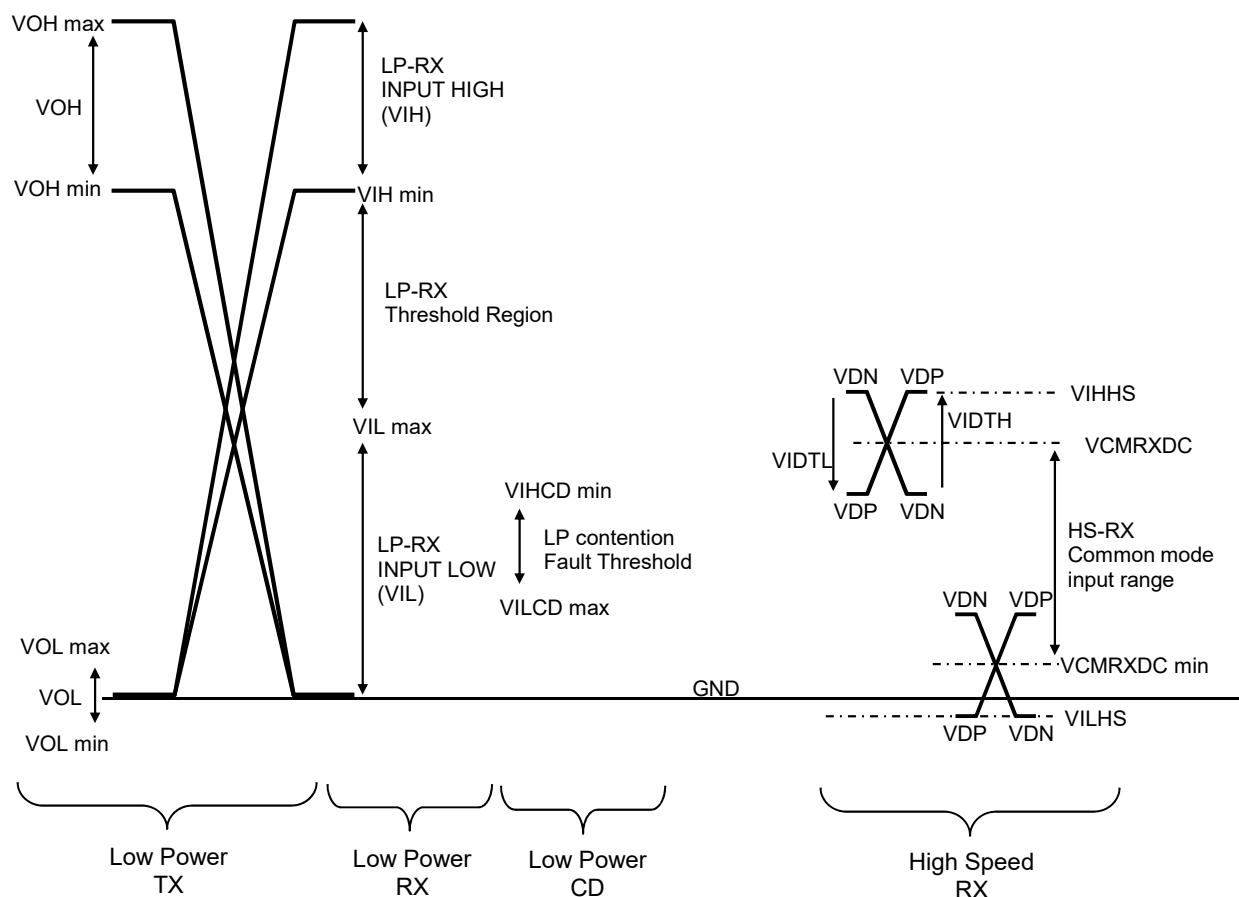

The signal levels for the LP and HS .

7.1.3 Backlight

Item	Symbol	Condition	Rating			Unit	Applicable terminal
			MIN	TYP	MAX		
Forward current	IL25	Ta=25 °C	--	7.0	35	mA	LED+ - LED-
	IL70	Ta=70 °C	--	--	15	mA	
Forward voltage	VL	Ta=25 °C IL=7.0mA	--	18.9	21.0	V	
Estimated Life of LED	LL	Ta=25 °C IL=7.0mA Note	--	20000	--	hrs	

- Note: - The lifetime of the LED is defined as a period till the brightness of the LED decreases to the half of its initial value.
- This figure is given as a reference purpose only, and not as a guarantee.
 - This figure is estimated for an LED operating alone.
- As the performance of an LED may differ when assembled as a monitor together with a TFT panel due to different environmental temperature.
- Estimated lifetime could vary on a different temperature and usually higher temperature could reduce the life significantly.

7.2 AC Characteristics

7.2.1 HS-RX Specifications

(Unless otherwise noted, Ta=25 °C, VDD=3.3V, VCCIO=1.8V, GND=0V)

Item	Symbol	Rating			Unit	Applicable terminal
		MIN	TYP	MAX		
DSICLK Frequency	f DSICLK	40	-	200	MHz	DSI_CP/N
DSICLK Cycle time	TCLKP	5.0	-	25.0	ns	
DSI Data Transfer Rate	UI	2.5	-	12.5	ns	DSI_D0P/N , DSI_D1P/N
	t DSIR	80	-	400	Mbps	
Data to Clock Setup Time	Tsetup	0.35	-	-	UI	DSI_D0P/N , DSI_D1P/N
Clock to Data Hold Time	Thold	0.25	-	-	UI	DSI_CP/N

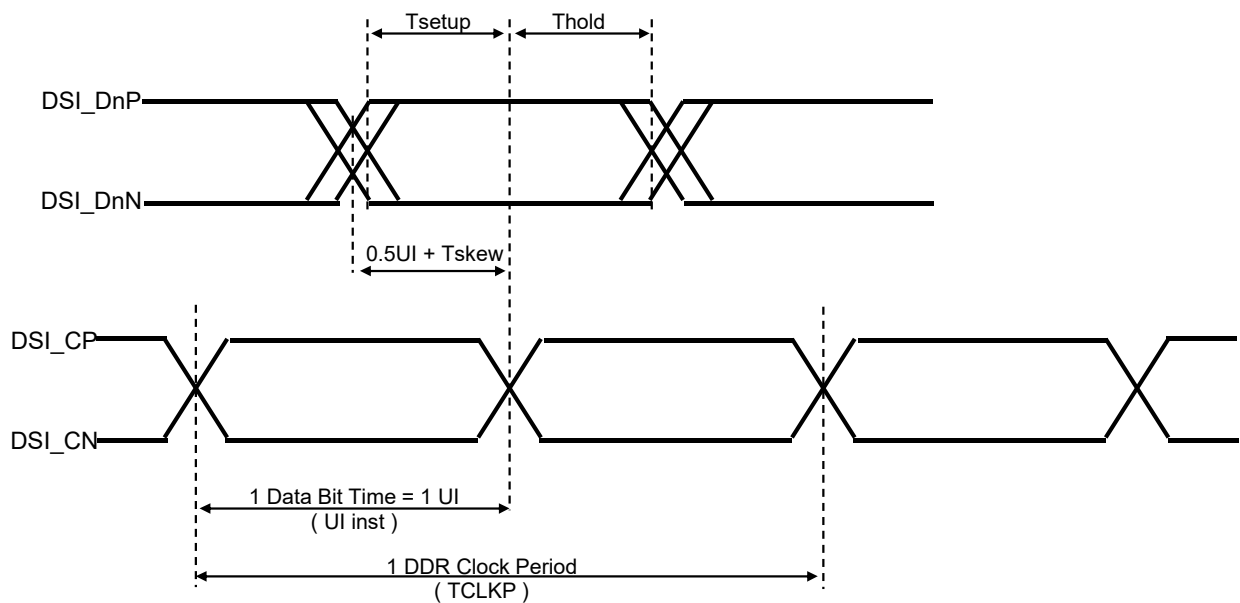

Data to Clock Timing Definitions

7.2.2 LP-TX Specifications

(Unless otherwise noted, Ta=25 °C, VDD=3.3V, VCCIO=1.8V, GND=0V)

Item	Symbol	Condition	Rating			Unit	Applicable terminal
			MIN	TYP	MAX		
15% - 85% rise time	TRLP		-	-	25	ns	DSI_D0P/N
85% - 15% fall time	TFLP		-	-	25	ns	DSI_D0P/N
Slew rate	$\Delta v / \Delta tSR$	Clload = 70pF	30	-	500	mV/ns	DSI_D0P/N

7.2.3 RX/TX Specifications

(Unless otherwise noted, $T_a=25\text{ }^\circ\text{C}$, $V_{DD}=3.3\text{V}$, $V_{CCIO}=1.8\text{V}$, $GND=0\text{V}$)

Item	Description	Rating			Unit
		MIN	TYP	MAX	
$T_{HS-PREPARE}$	Time to drive LP00 to prepare for HS transmission	40 ns + 4UI	-	85 ns + 6UI, $\leq 100\text{ ns}$	
$T_{HS-PREPARE} + T_{HS-ZERO}$	$T_{HS-PREPARE}$ + Time to drive HS0 before the SYNC sequence	145 ns + 10UI	-	-	
$T_{HS-TRAIL}$	Time to drive flipped differential state after last payload data bit of a HS transmission burst	$\max(n*8\text{UI}, 60\text{ ns} + n*4\text{UI})$	-	-	
$T_{HS-EXIT}$	Time to drive LP11 after HS burst	100	-	-	ns
T_{TA-GO}	Time to drive LP00 after turnaround Request	$4*T_{LPTX}$			
$T_{TA-SURE}$	Time out before new TX side starts driving	T_{LPTX}	-	$2*T_{LPTX}$	
T_{TA-GET}	Time to drive LP00 by new TX	$5*T_{LPTX}$			
T_{LPX}	Length of any Low Power state period	50	-	-	ns
Ratio T_{LPX}	Ratio of $T_{LPX}(\text{MASTER})/T_{LPX}(\text{SLAVE})$ between Master and Slave side	2/3	-	3/2	
$T_{CLK-POST}$	Time that the transmitter shall continue sending HS clock after the last associated Data Lane has transitioned to LP mode	60 ns + 52UI	-	-	
$T_{CLK-PREPARE} + T_{CLK-ZERO}$	$T_{CLK-PREPARE}$ + time for lead HS-0 drive period before starting Clock	300	-	-	ns
$T_{CLK-PRE}$	Time that the HS clock shall be driven prior to any associated Data Lane beginning the transition from LP to HS mode	8	-	-	UI
$T_{CLK-PREPARE}$	Time to drive LP-00 to prepare for HS clock transmission	38	-	95	ns
$T_{CLK-TRAIL}$	Time to drive HS differential state after last payload clock bit of a HS transmission burst	60	-	-	ns
T_{EOT}	Time from start of $T_{HS-TRAIL}$ period to start of LP-11 state	-	-	105 ns + $n*12\text{UI}$	
T_{LPTX1}	Length of Low-Power TX state period in case of using DSI clock	-	$n*DSITX$	-	UI
T_{LPTX2}	Length of Low-Power TX state period in case of using internal OSC clock	-	1/fosc	-	ns

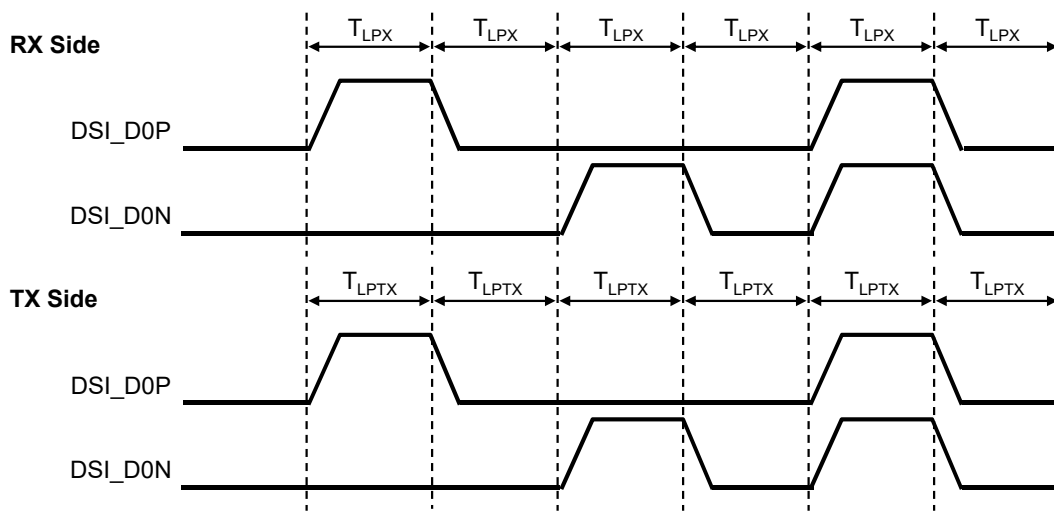
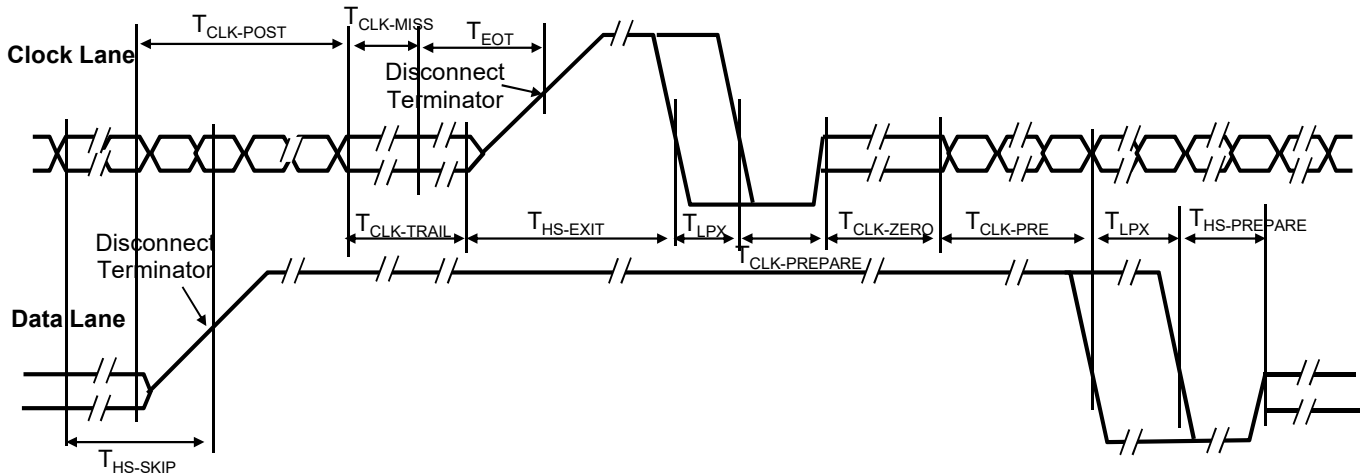
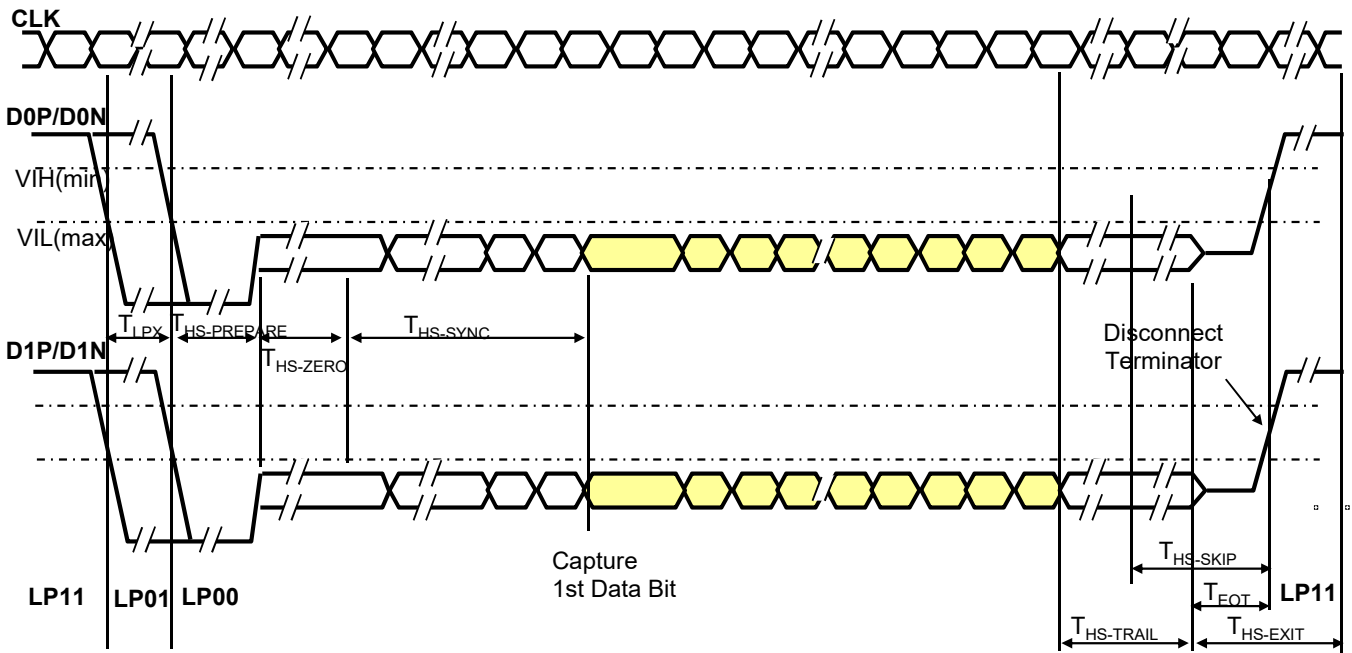

7.2.4 Reset input timing

Item	Symbol	Condition	Rating			Unit	Remark
			MIN	TYP	MAX		
Reset Low Pulse width	tRESW		10	-	-	us	
Reset Complete time	tREST	during Sleep In	-	-	5	ms	
		during Sleep Out	-	-	120	ms	

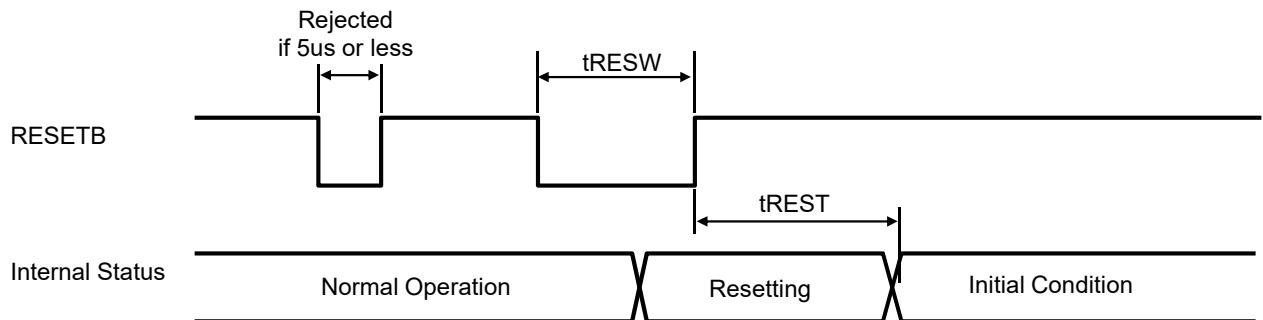

RESETB input timing

7.3 Input Timing Characteristics

Item	Symbol	Rating			Unit	Remark
		MIN	TYP	MAX		
CLK Frequency	fPCLK	--	25.0	--	MHz	PCLK
VSYNC Frequency	fVSYNC	54.0	57.5	63.2	Hz	VSYNC
VSYNC Cycle	tv	809	824	850	H	
VSYNC Pulse Width	tw4H	3	8	--	H	
Vertical Back Porch	tvb	6	8	--	H	
Vertical Front Porch	tvf	6	8	--	H	
Vertical Display Period	tvdp	800			H	
HSYNC frequency	fHSYNC	47.3			kHz	HSYNC
HSYNC Cycle	th	504	528	568	CLK	
HSYNC Pulse Width	tw5H	5	16	78	CLK	
Horizontal Back Porch	thb	5	16	78	CLK	
Horizontal Front Porch	thf	6	16	78	CLK	
Horizontal data start Point	tw5H+thb	19	32	83	CLK	
Horizontal Blanking Period	tw5H+thb+thf	24	48	88	CLK	
Horizontal Display Period	thdp	480			CLK	

Note: This is recommended spec to get high quality picture on display. It is customer's risk to use out of this frequency.

7.4 Input Signal Timing Chart

-Vertical Timing

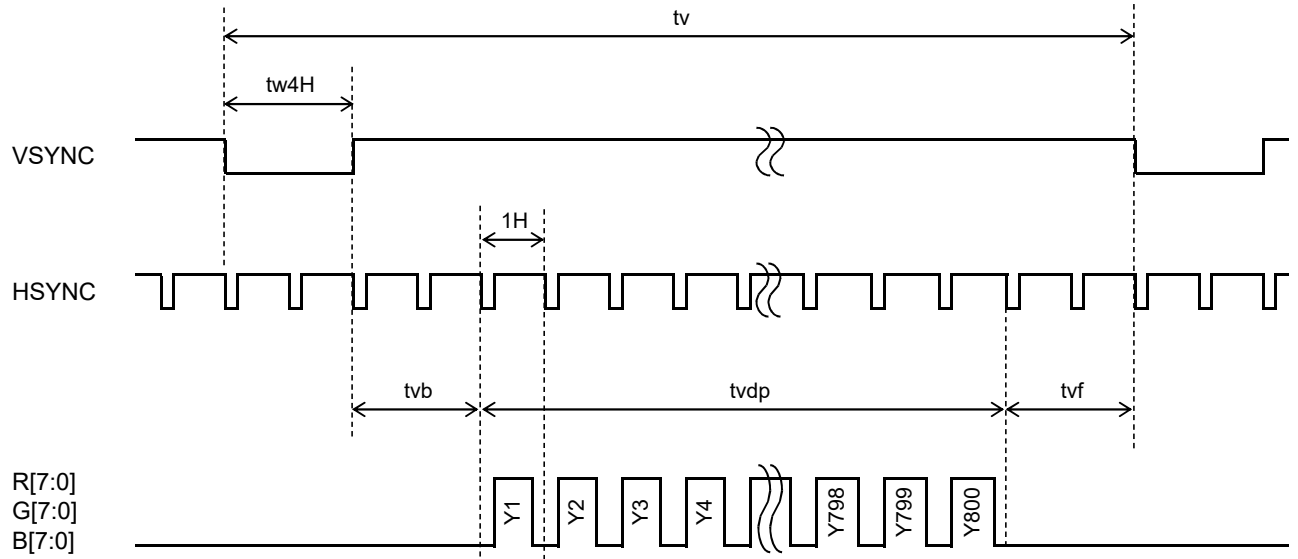

-Horizontal Timing

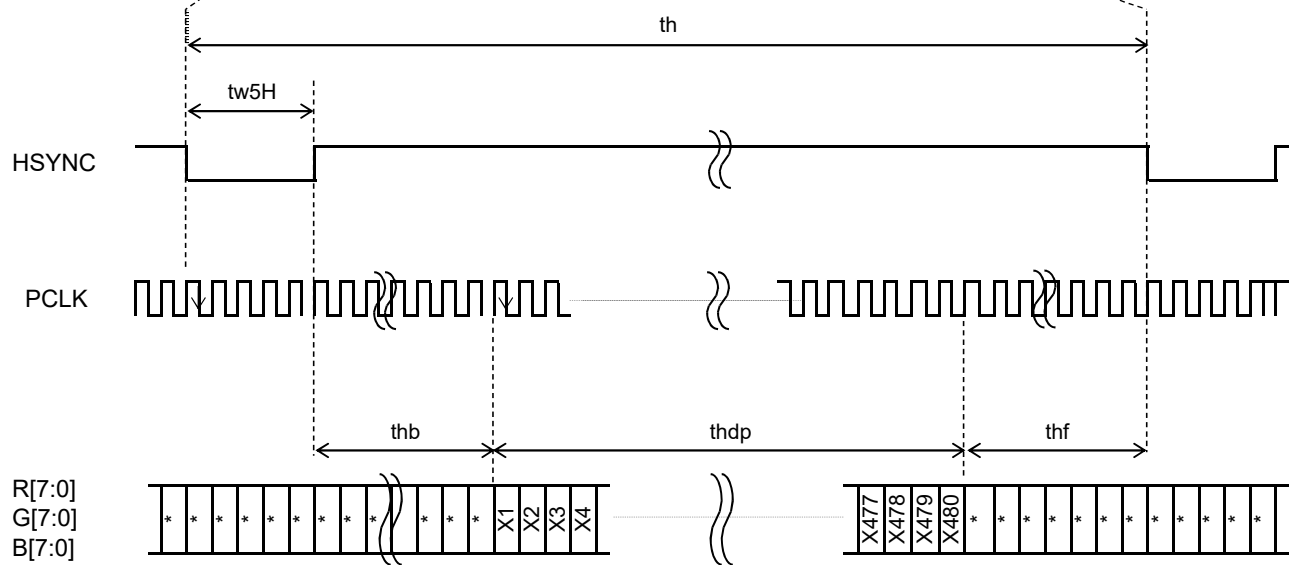

Timing Characteristics of input signals

8. About MIPI Interface

8.1 Version

The DSI incorporated in the LCD-Driver complies with the following standards.

MIPI DSI : Version 1.01

MIPI D-PHY : Version 1.00

Data transfer mode : Video mode only.

If the DSI_CLK lane becomes unintentionally at the LP (Low Power) level due to the influence of noise such as ESD, it may malfunction.

As a countermeasure for this, we recommend turning DSI_CLK OFF (LP) during the blanking period.

Virtual Channel : Set to VC[1:0]=00.

8.2 DSI protocol

- Short packets specify the payload length using the Data Type field and are from 2 to 9 bytes in length. Short packets is used for most Command Mode commands and associated parameters.

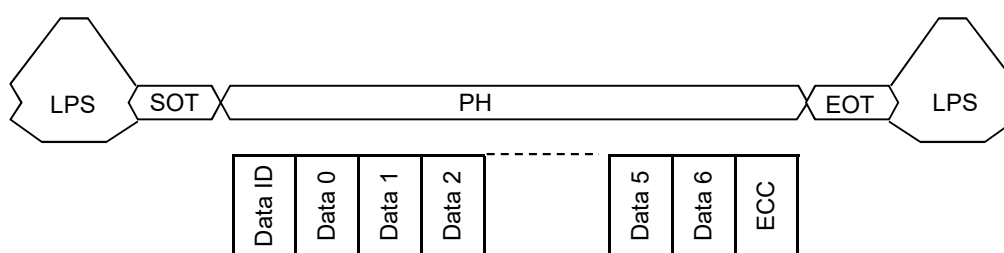

LPS : Low power state

SOT : Start of Transmission

PH : Packet Header

DI(Data ID) : Contain Virtual Channel Identifier and Data Type

ECC : Error Correction Code

- Long packets specify the payload length using a two-byte Word Count field and then the payload maybe 0 to 65,541 bytes in length. Long packets permit transmission of large blocks of pixel or other data.

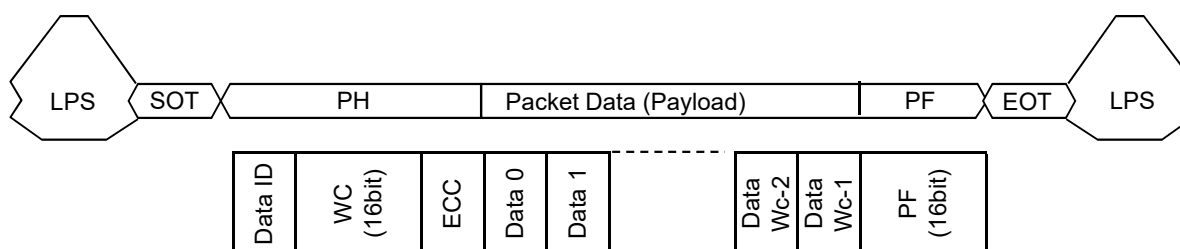

LPS : Low power state

SOT : Start of Transmission

PH : Packet Header

DI(Data ID) : Contain Virtual Channel Identifier and Data Type

WC(Word Count) : The receiver use WC to define packet end.

ECC : Error Correction Code

PF(Packet Footer) : Mean 16-bit Checksum.

8.3 Packet data types

LCD-Driver has the following restriction.

Generic short / Long Write Cmd is not supported.

It is only DCS Short / Long Write Cmd.

Processor to peripheral direction

Data Type Hex	Description	Size
01 h	Sync Event , V Sync Start (01,00,00,07)	Short
11 h	Sync Event , V Sync End (11,00,00,14)	Short
21 h	Sync Event , H Sync Start (21,00,00,12)	Short
31 h	Sync Event , H Sync End (31,00,00,01)	Short
22 h	Shut Down Peripheral Command (22,00,00,1E)	Short
32 h	Turn On Peripheral Command (32,00,00,0D)	Short
05 h	DCS WRITE , no parameters	Short
15 h	DCS WRITE , one parameters	Short
06 h	DCS READ , no parameters	Short
37 h	Set Maximum Return Packet Size	Short
08 h	End of Transmission Packet (08,0F,0F,01)	Short
09 h	Null Packet , no data	Long
19 h	Blanking Packet , no data	Long
39 h	DCS Long Write Command Packet	Long
0E h	Packed Pixel Stream , 16-bit RGB , 5-6-5 Format	Long
1E h	Packed Pixel Stream , 18-bit RGB , 6-6-6 Format	Long
2E h	Loosely Packed Pixel Stream , 18-bit RGB ,6-6-6 Format	Long
3E h	Packed Pixel Stream , 24-bit RGB , 8-8-8 Format	Long

Peripheral to processor direction

Data Type Hex	Description	Size
02 h	Acknowledge with Error Report	Short
1C h	DCS Long READ Response	Long

8.4 Packet Footer on the long packet

After Packet Data, Packet Footer is added in Long packet. Packet Footer adds CRC calculated from Packet Data as Checksum.

Checksum(2byte) = CRC(Packet Data)

$CRC = X^{16} + X^{12} + X^5 + X^0$

9. Sequence

9.1 Power-ON Sequence

PH :Packet Header

PD :Packet Data

PF:Packet Footer (=Checksum)

No.		Function	DNC	Command /Parameter	Type	Command/Parameter
		RESETB=0				
	Power on	VDD, VCCIO on				
	Wait	wait 10 msec or more				
		RESETB=1				
	MIPI signal state	keep CLKN, CLKP, D0N, D0P, D1N, D1P in STOP state (LP-11)				
	Wait	wait 10 msec or more				
1	Sleep out	Sleep out	0	11h	PH	[05 11 00 36]
	Wait	wait 100 msec or more				
2	Enable extended commands	Enable extended commands	0	B9h	PH	[39 04 00 2C]
		Parameter 1	1	FFh	PD	[B9 FF 83 63]
		Parameter 2	1	83h	PF	[XX XX]
		Parameter 3	1	63h		
3	Set lane number/ operation mode	Two data lane, Sync Pulses mode *1	0	BAh	PH	[39, 0E, 00, 15]
		Parameter 1	1	80h	PD	[BA 80 00 10 08 08 10 7E 6E 6D 0A 01 80 43]
		Parameter 2	1	00h	PF	[XX XX]
		Parameter 3	1	10h		
		Parameter 4	1	08h		
		Parameter 5	1	08h		
		Parameter 6	1	10h		
		Parameter 7	1	7Eh		
		Parameter 8	1	6Eh		
		Parameter 9	1	6Dh		
		Parameter 10	1	0Ah		
		Parameter 11	1	01h		
		Parameter 12	1	80h		
		Parameter 13	1	43h		
4	Memory access control	Memory access control	0	36h	PH	[15 36 00 29]
		Parameter 1	1	00h		
5	Interface pixel format	Interface pixel format	0	3Ah	PH	[15 3A 70 28]
		Parameter 1(24bit/pixel)	1	70h		
	Wait	wait 5 msec or more				
6	Set power	Set power	0	B1h	PH	[39 0D 00 13]
		Parameter 1	1	78h	PD	[B1 78 24 06 02 02 03 10 10 34 3C 3F 3F]
		Parameter 2	1	24h	PF	[XX XX]
		Parameter 3	1	06h		
		Parameter 4	1	02h		
		Parameter 5	1	02h		
		Parameter 6	1	03h		
		Parameter 7	1	10h		
		Parameter 8	1	10h		
		Parameter 9	1	34h		
		Parameter 10	1	3Ch		
		Parameter 11	1	3Fh		
		Parameter 12	1	3Fh		



PH :Packet Header

PD :Packet Data

PF:Packet Footer (=Checksum)

No.		Function	DNC	Command /Parameter	Type	Command/Parameter
7	Set display waveform cycle	Set display waveform cycle	0	B4h	PH	[39 0A 00 36]
		Parameter 1	1	00h	PD	[B4 00 08 6E 07 01 01 5E 01 57]
		Parameter 2	1	08h	PF	[XX XX]
		Parameter 3	1	6Eh		
		Parameter 4	1	07h		
		Parameter 5	1	01h		
		Parameter 6	1	01h		
		Parameter 7	1	5Eh		
		Parameter 8	1	01h		
		Parameter 9	1	57h		
8	Set panel	Set panel	0	CCh	PH	[15 CC 0B 22]
		Parameter 1	1	0Bh		
9	Set gamma curve related setting	Set gamma curve related setting	0	E0h	PH	[39 1F 00 29]
		Parameter 1	1	01h	PD	[E0 01 48 50 4E 58 F6 0B 4E 52 D5 15 95 55 CE 11 01 88 50 55 5F FD 0A 4E 91 D3 17 95 96 8E 11]
		Parameter 2	1	48h		
		Parameter 3	1	50h	PF	[XX XX]
		Parameter 4	1	4Eh		
		Parameter 5	1	58h		
		Parameter 6	1	F6h		
		Parameter 7	1	0Bh		
		Parameter 8	1	4Eh		
		Parameter 9	1	52h		
		Parameter 10	1	D5h		
		Parameter 11	1	15h		
		Parameter 12	1	95h		
		Parameter 13	1	55h		
		Parameter 14	1	CEh		
		Parameter 15	1	11h		
		Parameter 16	1	01h		
		Parameter 17	1	88h		
		Parameter 18	1	50h		
		Parameter 19	1	55h		
		Parameter 20	1	5Fh		
		Parameter 21	1	FDh		
		Parameter 22	1	0Ah		
		Parameter 23	1	4Eh		
		Parameter 24	1	91h		
		Parameter 25	1	D3h		
		Parameter 26	1	17h		
		Parameter 27	1	95h		
		Parameter 28	1	96h		
		Parameter 29	1	8Eh		
		Parameter 30	1	11h		
	Wait	wait 5 msec or more				
10	Display on	Display on	1	29h	PH	[05 29 00 1C]
11	Video stream					...
						...
						...

*1 The described value is Sync Pulses mode in DSI interface.

If you want to changes the lane number/ operation mode. Please follow the under packet to change it.

Two data lane, Sync Pulses mode :

Packet header [39, 0E, 00, 15],

Packet data [BA 80 00 10 08 08 10 7E 6E 6D 0A 01 80 43],

Packet footer[XX XX]

Two data lane, Sync Events mode/Burst mode :

Packet header [39, 0E, 00, 15],

Packet data [BA 80 00 10 08 08 10 7E 6E 6D 0A 01 84 43],

Packet footer[XX XX]

One data lane, Sync Pulses mode :

Packet header [39, 0E, 00, 15],

Packet data [BA 80 00 10 08 08 10 7E 6E 6D 0A 00 80 43],

Packet footer[XX XX]

One data lane, Sync Events mode/Burst mode :

Packet header [39, 0E, 00, 15],

Packet data [BA 80 00 10 08 08 10 7E 6E 6D 0A 00 84 43],

Packet footer[XX XX]

9.2 Power-OFF Sequence

PH :Packet Header

PD :Packet Data

PF:Packet Footer (=Checksum)

No.		Function	DNC	Command /Parameter	Type	Command/Parameter
1	Display off	Display off	0	28h	PH	[05 28 00 06]
	Wait	wait 5 msec or more				
2	Sleep in	Sleep in	0	10h	PH	[05 10 00 2C]
	Wait	wait 2 frames or more				
3	Video signals	Video signals stop				

↓
Power off

9.3 Sleep Sequence

No.		Function	DNC	Command /Parameter	Type	Command/Parameter
1	Sleep in	Sleep in	0	10h	PH	[05 10 00 2C]
	Wait	wait 2 frames or more				
2	Video signals	Video signals stop				

9.4 Sleep Release Sequence

No.		Function	DNC	Command /Parameter	Type	Command/Parameter
1	Video signals	Video signals start				
	Wait	wait 2 frames or more				
2	Sleep out	Sleep out	0	11h	PH	[05 11 00 36]

9.5 Power ON/OFF timing

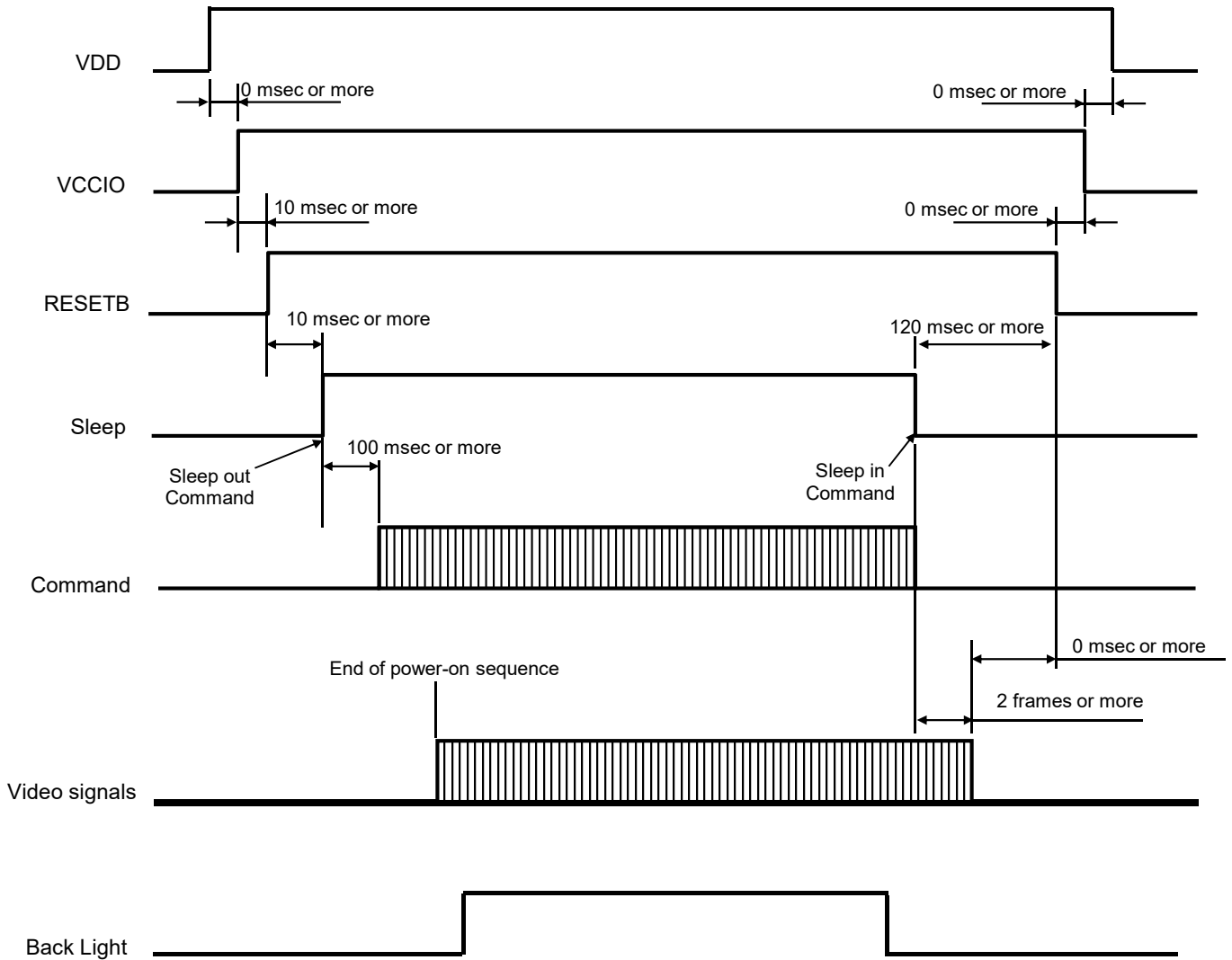

* It is recommended that backlight is turned ON after display-on and turned OFF before entering sleep-in.

9.6 Refresh Sequence

PH :Packet Header

PD :Packet Data

PF:Packet Footer (=Checksum)

No.		Function	DNC	Command /Parameter	Type	Command/Parameter
1	Sleep out	Sleep out	0	11h	PH	[05 11 00 36]
	Wait	wait 100 msec or more				
2	Enable extended commands	Enable extended commands	0	B9h	PH	[39 04 00 2C]
		Parameter 1	1	FFh	PD	[B9 FF 83 63]
		Parameter 2	1	83h	PF	[XX XX]
		Parameter 3	1	63h		
3	Set lane number/ operation mode	Two data lane, Sync Pulses mode *1	0	BAh	PH	[39, 0E, 00, 15]
		Parameter 1	1	80h	PD	[BA 80 00 10 08 08 10 7E 6E 6D 0A 01 80 43]
		Parameter 2	1	00h	PF	[XX XX]
		Parameter 3	1	10h		
		Parameter 4	1	08h		
		Parameter 5	1	08h		
		Parameter 6	1	10h		
		Parameter 7	1	7Eh		
		Parameter 8	1	6Eh		
		Parameter 9	1	6Dh		
		Parameter 10	1	0Ah		
		Parameter 11	1	01h		
		Parameter 12	1	80h		
		Parameter 13	1	43h		
4	Memory access control	Memory access control	0	36h	PH	[15 36 00 29]
		Parameter 1	1	00h		
5	Interface pixel format	Interface pixel format	0	3Ah	PH	[15 3A 70 28]
		Parameter 1(24bit/pixel)	1	70h		
	Wait	wait 5 msec or more				
6	Set power	Set power	0	B1h	PH	[39 0D 00 13]
		Parameter 1	1	78h	PD	[B1 78 24 06 02 02 03 10 10 34 3C 3F 3F]
		Parameter 2	1	24h	PF	[XX XX]
		Parameter 3	1	06h		
		Parameter 4	1	02h		
		Parameter 5	1	02h		
		Parameter 6	1	03h		
		Parameter 7	1	10h		
		Parameter 8	1	10h		
		Parameter 9	1	34h		
		Parameter 10	1	3Ch		
		Parameter 11	1	3Fh		
		Parameter 12	1	3Fh		



PH :Packet Header

PD :Packet Data

PF:Packet Footer (=Checksum)

No.		Function	DNC	Command /Parameter	Type	Command/Parameter
7	Set display waveform cycle	Set display waveform cycle	0	B4h	PH	[39 0A 00 36]
		Parameter 1	1	00h	PD	[B4 00 08 6E 07 01 01 5E 01 57]
		Parameter 2	1	08h	PF	[XX XX]
		Parameter 3	1	6Eh		
		Parameter 4	1	07h		
		Parameter 5	1	01h		
		Parameter 6	1	01h		
		Parameter 7	1	5Eh		
		Parameter 8	1	01h		
		Parameter 9	1	57h		
8	Set panel	Set panel	0	CCh	PH	[15 CC 0B 22]
		Parameter 1	1	0Bh		
9	Set gamma curve related setting	Set gamma curve related setting	0	E0h	PH	[39 1F 00 29]
		Parameter 1	1	01h	PD	[E0 01 48 50 4E 58 F6 0B 4E 52 D5 15 95 55 CE 11 01 88 50 55 5F FD 0A 4E 91 D3 17 95 96 8E 11]
		Parameter 2	1	48h		
		Parameter 3	1	50h	PF	[XX XX]
		Parameter 4	1	4Eh		
		Parameter 5	1	58h		
		Parameter 6	1	F6h		
		Parameter 7	1	0Bh		
		Parameter 8	1	4Eh		
		Parameter 9	1	52h		
		Parameter 10	1	D5h		
		Parameter 11	1	15h		
		Parameter 12	1	95h		
		Parameter 13	1	55h		
		Parameter 14	1	CEh		
		Parameter 15	1	11h		
		Parameter 16	1	01h		
		Parameter 17	1	88h		
		Parameter 18	1	50h		
		Parameter 19	1	55h		
		Parameter 20	1	5Fh		
		Parameter 21	1	FDh		
		Parameter 22	1	0Ah		
		Parameter 23	1	4Eh		
		Parameter 24	1	91h		
		Parameter 25	1	D3h		
		Parameter 26	1	17h		
		Parameter 27	1	95h		
		Parameter 28	1	96h		
		Parameter 29	1	8Eh		
Parameter 30	1	11h				
	Wait	wait 5 msec or more				
10	Display on	Display on	1	29h	PH	[05 29 00 1C]

10. LED Circuit

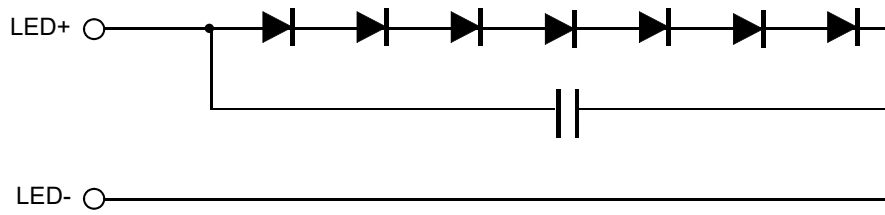

11. Characteristics

11.1 Optical Characteristics

< Measurement Condition >

Measuring instruments: CS2000 (KONICA MINOLTA), LCD7200(OTSUKA ELECTRONICS),
EZcontrastXL88 (ELDIM)

Driving condition: VDD = 3.3V, VCCIO = 1.8V, GND=0V
Optimized VCOMDC

Backlight: IL=7.0mA

Measured temperature: Ta=25° C

Item		Symbol	Condition	MIN	TYP	MAX	Unit	Note No.	Remark
Response time	Rise time	TON	[Data]= 00h→FFh	—	—	40	ms	1	
	Fall time	TOFF	[Data]= FFh→00h	—	—	60	ms		
Contrast ratio	Backlight ON	CR	[Data]= FFh / 00h	—	600	—		2	
	Backlight OFF			—	3	—			
Viewing angle	Left	θL	[Data]= FFh / 00h CR ≥ 10	—	80	—	deg	3	
	Right	θR		—	80	—	deg		
	Up	φU		—	80	—	deg		
	Down	φD		—	80	—	deg		
White Chromaticity		x	[Data]=FFh	White chromaticity range				4	
		y							
Burn-in				No noticeable burn-in image should be observed after 2 hours of window pattern display.				5	
Center brightness			[Data]=FFh	210	300	—	cd/m ²	6	
Brightness distribution			[Data]=FFh	70	—	—	%	7	

* Note number 1 to 7: Refer to the APPENDIX of "Reference Method for Measuring Optical Characteristics".

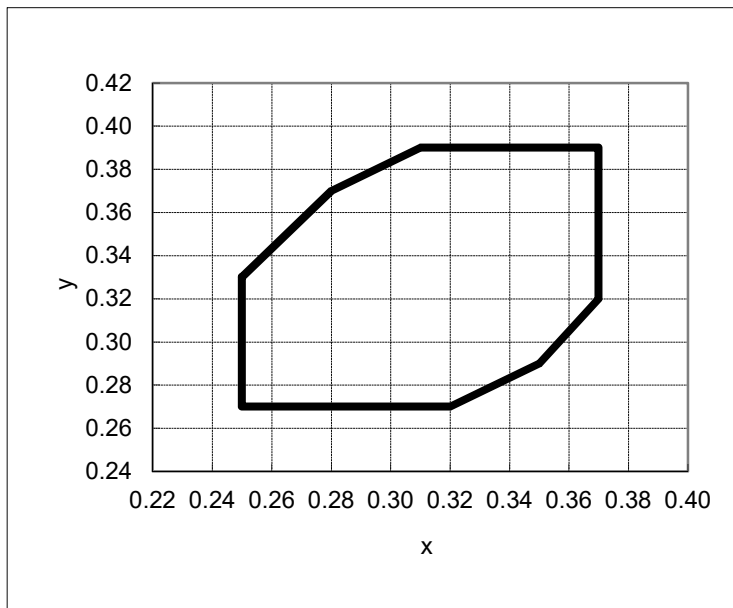

【White Chromaticity Range】

x	y
0.25	0.33
0.25	0.27
0.32	0.27
0.35	0.29
0.37	0.32
0.37	0.39
0.31	0.39
0.28	0.37

White Chromaticity Range

11.2 Temperature Characteristics

< Measurement Condition >

Measuring instruments: CS2000 (KONICA MINOLTA), LCD7200(OTSUKA ELECTRONICS)

Driving condition: VDD = 3.3V, VCCIO = 1.8V, GND=0V

Optimized VCOMDC

Backlight: IL=7.0mA

Item		Specification		Remark	
		Ta=-10° C	Ta=70° C		
Contrast ratio	CR	200 or more	200 or more	Backlight ON	
Response time	Rise time	TON	200 msec or less	30 msec or less	
	Fall time	TOFF	300 msec or less	50 msec or less	
Display Quality		No noticeable display defect or nonuniformity should be observed.			

12. Criteria of Judgment

12.1 Defective Display and Screen Quality

Test Condition: Observed TFT-LCD monitor from front during operation with the following conditions

Driving Signal Raster Patter (RGB, white, black)

Signal condition [Data]: FFh, 98h, 00h (3steps)

Observation distance 30 cm

Illuminance 200 to 350 lx

Backlight IL=7.0mA

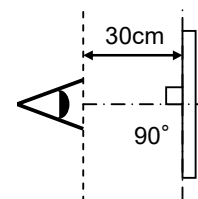

Defect item	Defect content		Criteria	
Display Quality	Line defect	Black, white or color line, 3 or more neighboring defective dots	Not exists	
	Dot defect	Uneven brightness on dot-by-dot base due to defective TFT or CF, or dust is counted as dot defect (brighter dot, darker dot)	Refer to table 1	
		High bright dot: Visible through 2% ND filter at [Data]=00h	Acceptable	
		Low bright dot: Visible through 5% ND filter at [Data]=00h Dark dot: Appear dark through white display at [Data]=98h Invisible through 5% ND filter at [Data]=00h		
Screen Quality	Dirt	Uneven brightness (white stain, black stain etc)	Invisible through 5% ND filter at Black screen. Invisible through 1% ND filter at other screen.	
	Foreign particle	Point-like	$0.25\text{mm} < \phi$	N=0
			$0.20\text{mm} < \phi \leq 0.25\text{mm}$	$N \leq 2$
			$\phi \leq 0.20\text{mm}$	Acceptable
		Liner	$3.0\text{mm} < \text{length and } 0.08\text{mm} < \text{width}$ $\text{length} \leq 3.0\text{mm or width} \leq 0.08\text{mm}$	N=0 Acceptable
	Others		Use boundary sample for judgment when necessary	

Permissible number: N

Table 1

Area	High bright dot	Low bright dot	Dark dot	Total	Criteria
A	0	2	2	3	Permissible distance between same color bright dots (includes neighboring dots): 3 mm or more Permissible distance between same color high bright dots (includes neighboring dots): 5 mm or more
B	2	4	4	6	
Total	2	4	4	7	

<Portrait model>

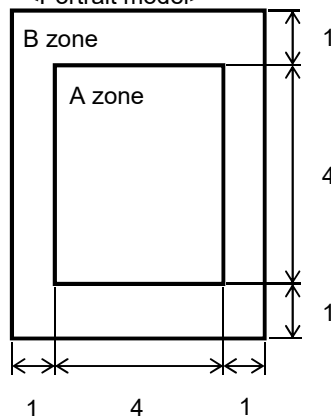

Division of A and B areas

B area: Active area

Dimensional ratio between A and B areas: 1: 4: 1 (Refer to the left figure)

12.2 Screen and Other Appearance

Testing conditions

Observation distance	30cm
Illuminance	1200~2000 lx

Item	Criteria	Remark
Polarizer Flaw Stain Bubble Dust Dent	Ignore invisible defect when the backlight is on.	Applicable area: Active area only (Refer to the section 3.2 "Outward form")
S-case	No functional defect occurs	
FPC cable	No functional defect occurs	

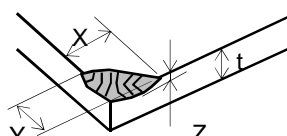
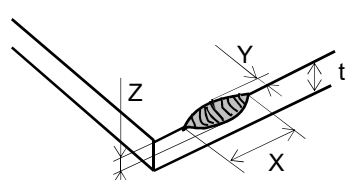
Item	Appearance	Criteria
Glass Chipping	Corner area 	Unit: mm $X \leq 3$ $Y \leq 3$ $Z \leq t$ (t:glass thickness) In case that either X or Y is less than 0.5mm, the other can be ignored.
	Others 	Unit: mm $X \leq 5$ $Y \leq 1$ $Z \leq t$ (t:glass thickness) In case that either X or Y is less than 0.5mm, the other can be ignored.
	Progressive crack	None

13. Reliability Test

Test item		Test condition		number of failures /number of examinations
Durability test	High temperature storage	Ta=80° C	240hrs	0 / 3
	Low temperature storage	Ta=-30° C	240hrs	0 / 3
	High temperature & high humidity storage	Ta=60° C, RH=90% non condensing	240hrs	0 / 3
	High temperature operation	Tp=70° C	240hrs	0 / 3
	Low temperature operation	Tp=-20° C	240hrs	0 / 3
	High temp & humid operation	Tp=40° C, RH=90% non condensing	240hrs	0 / 3
	Thermal shock storage	-30←→80° C(30min/30min)	100 cycles	0 / 3
	Lightfastness	Xenon Blackpanel 63±3°C non-shower 450W/m ² (300~700nm) non-operating Integral dose 800MJ/m ²		0 / 3
Mechanical environmental test	Electrostatic discharge test (Non operation)	Confirms to EIAJ ED-4701/300 C=200pF,R=0Ω,V=±200V Each 3 times of discharge on and power supply and other terminals.		0 / 3
	Vibration test	Total amplitude 1.5mm, f=10~55Hz, X,Y,Z directions for each 2 hours		0 / 3
	Impact test	Use TOPPAN PRINTING original jig (see next page)and make an impact with peak acceleration of 1000m/s ² for 6 msec with half sine-curve at 3 times to each X, Y, Z directions in conformance with JIS C 60068-2-27-2011.		0 / 3
Packing test	Packing vibration-proof test	Acceleration of 19.6m/s ² with frequency of 10→55→10Hz, X,Y, Zdirection for each 30 minutes		0 / 1 packing
	Packing drop test	Drop from 75cm high. 1 time to each 6 surfaces, 3 edges, 1 corner		0 / 1 packing

Note:Ta=ambient temperature Tp=Panel temperature

※ The profile of high temperature/humidity storage and High Temperature/humidity operation (Pure water of over 10MΩ·cm shall be used.)

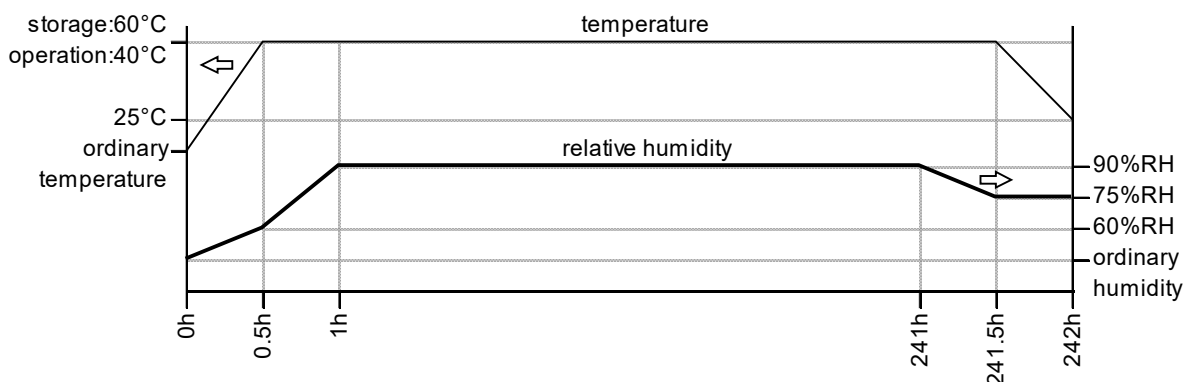
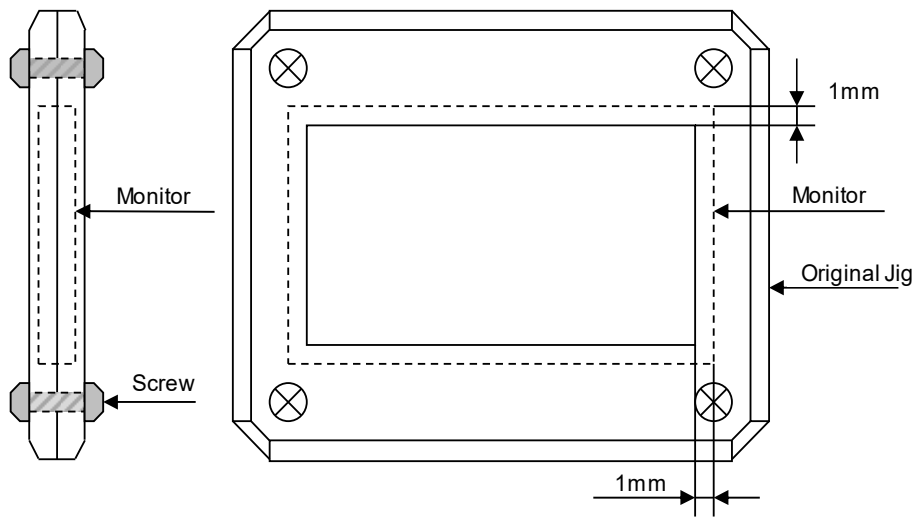

Table2 .Reliability Criteria

Measure the parameters after leaving the monitor at the ordinary temperature for 24 hours or more after the test completion.

item	Standard	Remarks
Display quality	No visible abnormality shall be seen.	
Contrast ratio	200 or more	Backlight ON

TOPPAN PRINTING Original Jig



14. Packing Specifications

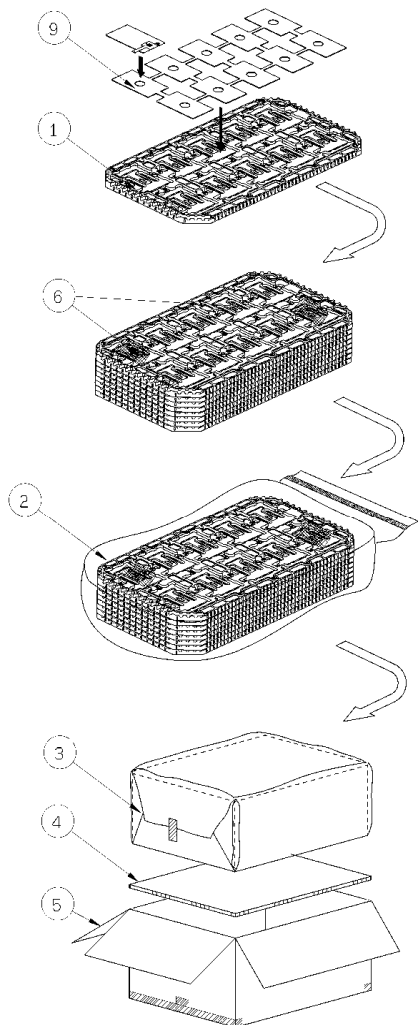

Step1. Foam sheet is put on the tray.

Each product is to be placed in one of the cut-outs of the tray with the display surface facing downward. (10 products per tray)

Step 2. Each tray needs to be same orientation respect to the tray below or above it and the trays be in a stack of 7.

One empty tray is to be put on the top of stack of 7 trays.

Step 3. 2 packs of moisture absorbers are to be placed on the top tray as shown in the drawing. Put piled trays into a sealing bag.

Vacuum and seal the sealing bag with the vacuum sealing machine.

Step 4. The piled trays are to be wrapped with a bubble cushioning sheet, and to be fixed with adhesive tape.

Step 5. The inner board is put in the outer carton.

The wrapped trays are to be put in the outer carton.

Step 6. The outer carton needs to sealed with packing tape as shown in the drawing. The model number, quantity of products, and shipping date are to be printed on the outer carton.

If necessary, shipping labels or impression markings are to be put on the outer carton.

Step 7. The outer carton is to be inserted into a extra outer carton with same direction. The extra outer carton needs to sealed with packing tape as shown in the drawing.

Step 8. The model number, quantity of products, and shipping date are to be printed on the extra outer carton. If necessary, shipping labels or impression markings are to be put on the extra outer carton.

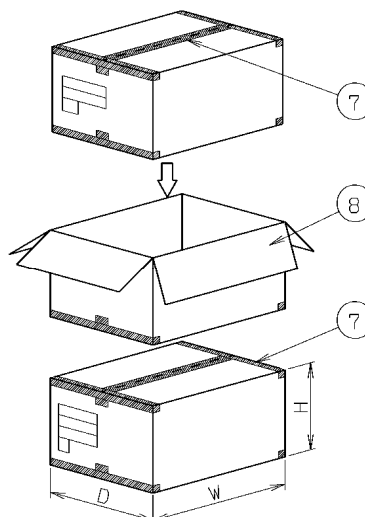

Remark: The return of packing materials is not required.

Packing item name	Specs., Material
① Tray	A-PET
② Sealing bag	
③ B sheet A	Anti-static air bubble sheet
④ Inner board	Corrugated cardboard
⑤ Outer carton	Corrugated cardboard
⑥ Drier	Moisture absorber
⑦ Packing tape	
⑧ Extra outer carton	Corrugated cardboard
⑨ Foam sheet	PE Anti-static

Dimension of extra outer carton	
D : Approx.	(337mm)
W : Approx.	(618mm)
H : Approx.	(179mm)
Quantity of products packed in one carton:	10 pcs × 7 = 70 pcs
Gross weight : Approx.	4.8 kg

15. Handling Instruction

15.1 Cautions for Handling LCD panels

**Caution**

- (1) Do not make an impact on the LCD panel glass because it may break and you may get injured from it.
- (2) If the glass breaks, do not touch it with bare hands.
(Fragment of broken glass may stick you or you cut yourself on it.)
- (3) If you get injured, receive adequate first aid and consult a medial doctor.
- (4) Do not let liquid crystal get into your mouth.
(If the LCD panel glass breaks, try not let liquid crystal get into your mouth even toxic property of liquid crystal has not been confirmed.)
- (5) If liquid crystal adheres, rinse it out thoroughly.
(If liquid crystal adheres to your cloth or skin, wipe it off with rubbing alcohol or wash it thoroughly with soap. If liquid crystal gets into eyes, rinse it with clean water for at least 15 minutes and consult an eye doctor.)
- (6) If you scrap this products, follow a disposal standard of industrial waste that is legally valid in the community, country or territory where you reside.
- (7) Do not connect or disconnect this product while its application products is powered on.
- (8) Do not attempt to disassemble or modify this product as it is precision component.
- (9) If a part of soldering part has been exposed, and avoid contact (short-circuit) with a metallic part of the case etc. about FPC of this model, please.
Please insulate it with the insulating tape etc. if necessary.
The defective operation is caused, and there is a possibility to generation of heat and the ignition.
- (10) Since excess current protection circuit is not built in this TFT module, there is the possibility that LCD module or peripheral circuit become feverish and burned in case abnormal operation is generated.
We recommend you to add excess current protection circuit to power supply.
- (11) The devices on the FPC are damageable to electrostatic discharge, because the terminals of the devices are exposed.
Wear grounded wrist-straps and use electrostatic neutralization blowers to prevent static charge and discharge when handling the TFT monitors.
Designate an appropriate operating area, and set equipment, tools, and machines properly when handling this product.

**Caution**

This mark is used to indicate a precaution or an instruction which, if not correctly observed, may result in bodily injury, or material damages alone.

15.2 Precautions for Handling

- 1) Wear finger tips at incoming inspection and for handling the TFT monitors to keep display quality and keep the working area clean.
Do not touch the surface of the monitor as it is easily scratched.
- 2) Wear grounded wrist-straps and use electrostatic neutralization blowers to prevent static charge and discharge when handling the TFT monitors as the LED in this TFT monitors is damageable to electrostatic discharge.
Designate an appropriate operating area, and set equipment, tools, and machines properly when handling this product.
- 3) Avoid strong mechanical shock including knocking, hitting or dropping to the TFT monitors for protecting their glass parts. Do not use the TFT monitors that have been experienced dropping or strong mechanical shock.
- 4) Do not use or storage the TFT monitors at high temperature and high humidity environment. Particularly, never use or storage the TFT monitors at a location where condensation builds up.
- 5) Avoid using and storing TFT monitors at a location where they are exposed to direct sunlight or ultraviolet rays to prevent the LCD panels from deterioration by ultraviolet rays.
- 6) Do not stain or damage the contacts of the FPC cable .
FPC cable needs to be inserted until it can reach to the end of connector slot.
During insertion, make sure to keep the cable in a horizontal position to avoid an oblique insertion.
Otherwise, it may cause poor contact or deteriorate reliability of the FPC cable.
- 7) The FPC cable is a design very weak to the bend and the pull as it is fixed with the tape
Do not bend or pull the FPC cable or carry the TFT monitor by holding the FPC cable.
- 8) Peel off the protective film on the TFT monitors during mounting process.
Refer to the section 15.5 on how to peel off the protective film.
We are not responsible for electrostatic discharge failures or other defects occur when peeling off the protective film.
- 9) Please make it to the structure to suppress surroundings of the front polarizer for the display irregularity prevention.
- 10) By reason of this model is made by thin glass, this model LCD is breakable.
Please apply fitting of protection LCD surface. (ex. Covered acrylic board on LCD surface)

15.3 Precautions for Operation

- 1) Since this TFT monitors are not equipped with light shielding for the driver IC, do not expose the driver IC to strong lights during operation as it may cause functional failures.
- 2) When turning off the power, turn off the input signal before or at the same timing of switching off the power.
- 3) Do not plug in or out the FPC cable while power supply is switch on.
Plug the FPC cable in and out while power supply is switched off.
- 4) Do not operate the TFT monitors in the strong magnetic field. It may break the TFT monitors.
- 5) Do not display a fixed image on the screen for a long time.
Use a screen-saver or other measures to avoid a fixed image displayed on the screen for a long time.
Otherwise, it may cause burn-in image on the screen due the characteristics of liquid crystal.

15.4 Storage Condition for Shipping Cartons

Storage environment

- Temperature 0 to 40° C
- Humidity 60%RH or less
No-condensing occurs under low temperature with high humidity condition.
- Atmosphere No poisonous gas that can erode electronic components and/or wiring materials should be detected.
- Time period 1 year
- Unpacking To prevent damages caused by static electricity, anti-static precautionary measures (e.g. earthing, anti-static mat) should be implemented.
After unpack, keep product in the appropriate condition, otherwise bubble seal of Protective film may be printed on Polarizer.

*Conditions to storage after unpacking

Storage environment

- Temperature 0 to 40° C
- Humidity 60%RH or less
No-condensing occurs under low temperature with high humidity condition.
- Atmosphere No poisonous gas that can erode electronic components and/or wiring materials should be detected.
- Time period 1 year (Shelf life)
- Others Keep/ store away from direct sunlight
Storage goods on original tray made by TOPPAN PRINTING.

15.5 Precautions for Peeling off the Protective film

The followings work environment and work method are recommended to prevent the TFT monitors from static damage or adhesion of dust when peeling off the protective films.

A) Work Environment

- a) Humidity: 50 to 70 %RH, Temperature 15 to 27° C
- b) Operators should wear conductive shoes, conductive clothes, conductive finger tips and grounded wrist-straps. Anti-static treatment should be implemented to work area's floor.
- c) Use a room shielded against outside dust with sticky floor mat laid at the entrance to eliminate dirt.

B) Work Method

The following procedures should taken to prevent the driver ICs from charging and discharging.

- a) Use an electrostatic neutralization blower to blow air on the TFT monitors to its lower left when FPC is placed at the lower right.
Optimize direction of the blowing air and the distance between the TFT monitors and the electrostatic neutralization blower.
- b) Put an adhesive tape (Scotch tape, etc) at the lower right corner area of the protective film to prevent scratch on surface of TFT monitors.
- c) Peel off the adhesive tape slowly (spending more than 2 secs to complete) by pulling it to opposite direction.

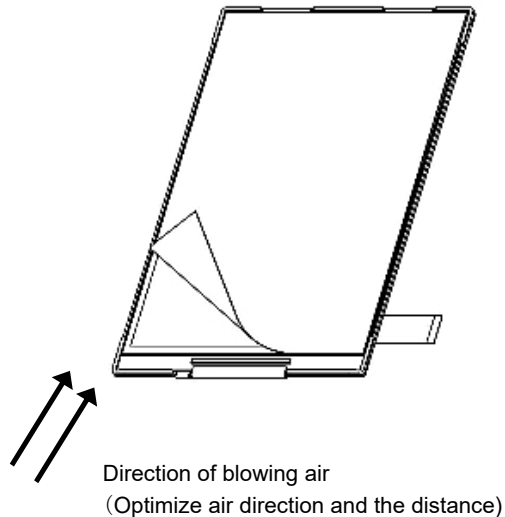

15.6 Warranty

TOPPAN PRINTING is only liable to defective goods which is stored and used under the condition complying with this specifications and returned within 1 (one) year.

Warranty caused by manufacturing defect shall be conducted by replacement of goods or refundment at unit price.

APPENDIX

Reference Method for Measuring Optical Characteristics and Performance

1. Measurement Condition (Backlight ON)

Measuring instruments: CS2000 (KONICA MINOLTA), LCD7200(OTSUKA ELECTRONICS),EZcontrastXL88 (ELDIM)

Driving condition: Refer to the section "Optical Characteristics"

Measured temperature: 25°C unless specified

Measurement system: See the chart below. The luminance meter is placed on the normal line of measurement system.

Measurement point: At the center of the screen unless otherwise specified

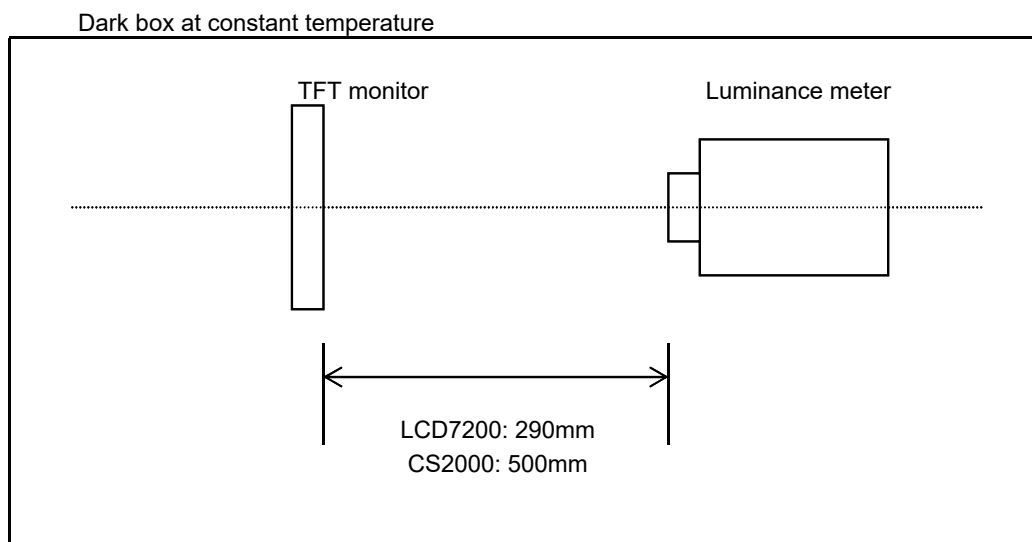

Measurement is made after 30 minutes of lighting of the backlight.

Measurement point: At the center point of the screen
Brightness distribution: 9 points shown in the following drawing.

<Portrait model>

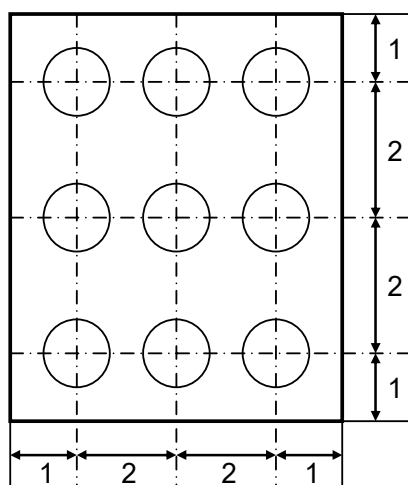

Dimensional ratio of active area

Backlight IL=7.0mA

Measurement Condition (Contrast ratio Backlight OFF only)

- Measuring instruments: LCD7200(OTSUKA ELECTRONICS),Ring Light(40,000 lx,φ58)
- Driving condition: Refer to the section "Optical Characteristics"
- Measured temperature: 25° C unless specified
- Measurement system: See the chart below.
- Measurement point: At the center of the screen.

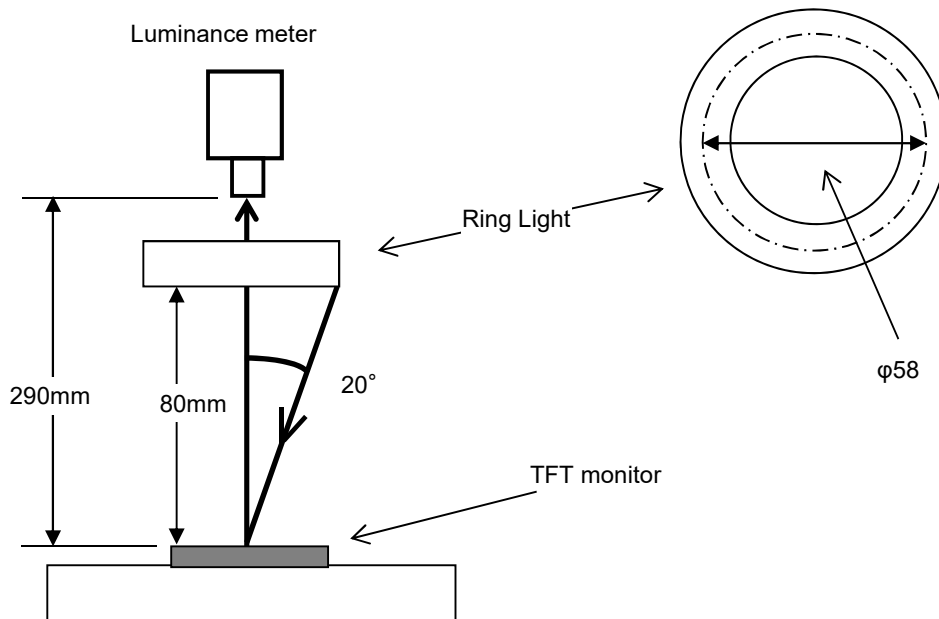

2. Test Method

Notice	Item	Test method	Measuring instrument	Remark
1	Response time	<p>Measure output signal waveform by the luminance meter when raster of window pattern is changed from white to black and from black to white.</p> <p style="text-align: center;">Black White Black</p> <p>White brightness</p> <p>100%</p> <p>90%</p> <p>10%</p> <p>0%</p> <p>Black brightness</p> <p>TON</p> <p>TOFF</p>	LCD7200	<p>Black display [Data]=00h</p> <p>White display [Data]=FFh</p> <p>TON</p> <p>Rise time</p> <p>TOFF</p> <p>Fall time</p>
2	Contrast ratio	<p>Measure maximum luminance Y1([Data]=FFh) and minimum luminance Y2([Data]=00h) at the center of the screen by displaying raster or window pattern. Then calculate the ratio between these two values.</p> <p style="text-align: center;">Contrast ratio = Y1/Y2</p> <p style="text-align: center;">Diameter of measuring point: 7.8mmφ(CS2000)</p> <p style="text-align: center;">Diameter of measuring point: 3mmφ(LCD7200)</p>	CS2000 LCD7200	Backlight ON Backlight OFF
3	Viewing angle Horizontalθ Verticalφ	Move the luminance meter from right to left and up and down and determine the angles where contrast ratio is 10.	EZcontrastXL88	
4	White chromaticity	<p>Measure chromaticity coordinates x and y of CIE1931 colorimetric system at [Data] = FFh</p> <p style="text-align: center;">Color matching faction: 2°view</p> <p style="text-align: center;">Measurement angle: 1°</p>	CS2000	
5	Burn-in	Visually check burn-in image on the screen after 2 hours of "window display" ([Data]=FFh/00h).		Optimized VCOMDC
6	Center brightness	Measure the brightness at the center of the screen.	CS2000	
7	Brightness distribution	<p>(Brightness distribution) = 100 x B/A %</p> <p>A : max. brightness of the 9 points</p> <p>B : min. brightness of the 9 points</p>	CS2000	



ALL TECHNOLOGIES. ALL COMPETENCIES. ONE SPECIALIST.



DATA MODUL AG
Landsberger Straße 322
DE-80687 Munich
Phone: +49-89-56017-0

DATA MODUL WEIKERSHEIM GMBH
Lindenstraße 8
DE-97990 Weikersheim
Phone: +49-7934-101-0



More information and worldwide locations can be found at

www.data-modul.com