



# SPECIFICATION

---

**ORTUSTECH**

**COM43H4N98UTC**

4.3" – 480 x 800 – MIPI – Blanview – Pcap-Touchpanel

Version: 1.0

Date: 15.06.2023

Note: This specification is subject to change without prior notice



**Specifications for**  
**Blanview TFT-LCD Monitor**  
**( 4.3" WVGA 480 x RGB x 800 Portrait )**

Version 1.0

(Please be sure to check the specifications latest version. )

MODEL COM43H4N98UTC

Customer's Approval

Signature :

Name :

Section :

Title :

Date :

# ORTUSTECH

TOPPAN INC.  
 Electronics Division  
 Technological Development Department III



Approved by

\_\_\_\_\_ *S. Epuchi*

Checked by

\_\_\_\_\_ *J. Matsuzaki*

Prepared by

\_\_\_\_\_ *M. Tojo*

Version History

Ver.	Date	Page	Description
0.0	Apr.7,2021	-	- Tentative issue
1.0  △ x9	Jun.15,2023	-	- First issue
		All	All
		P.1	Change Company name
		P.1	Change Cover
		P.9	Change Department name
		P.9	3.3 Serial Label (S-label)
		P.12	Correct Error correct
		P.12	6. Recommended Operating Conditions
		P.12	Correct Error correct
		P.32	Add 12.1 Optical Characteristics
		P.32	Add White Chromaticity Range
		P.35	Add 13.2 Screen and Other Appearance
P.35	Correct Error correct		
P.36	Add 14. Reliability Test		
P.36	Add number of failures /number of examinations		
P.38	Add 15. Packing Specifications		
P.38	Add Packing Specifications		
P.41	Add 16.4 Storage Condition for Shipping Cartons		
P.41	Add Maximum piling up		

## Contents

1. Application	.....	4
2. Outline Specifications		
2.1 Features of the Product	.....	5
2.2 Display Method	.....	5
3. Dimensions and Shape		
3.1 Dimensions	.....	7
3.2 Outward Form	.....	8
3.3 Serial Label (S-Label)	.....	9
4. Pin Assignment	.....	10
5. Absolute Maximum Rating	.....	12
6. Recommended Operating Conditions	.....	12
7. Electrical Characteristics		
7.1 DC Characteristics	.....	13
7.2 AC Characteristics	.....	15
7.3 LCD Input Timing Characteristics	.....	18
7.4 LCD Input Signal Timing Chart	.....	19
7.5 Touch Panel Characteristics	.....	20
8. About MIPI Interface		
8.1 Version	.....	21
8.2 DSI protocol	.....	21
8.3 Packet data types	.....	22
8.4 Packet Footer on the long packet	.....	22
9. Sequence		
9.1 LCD Power-ON Sequence	.....	23
9.2 LCD Power-OFF Sequence	.....	26
9.3 LCD Sleep Sequence	.....	26
9.4 LCD Sleep Release Sequence	.....	26
9.5 LCD Refresh Sequence	.....	27
9.6 Power ON/OFF timing	.....	29
10. TP Interface - I2C AC Characteristics	.....	30
11. LED Circuit	.....	31
12. Characteristics		
12.1 Optical Characteristics	.....	32
12.2 Temperature Characteristics	.....	33
13. Criteria of Judgment		
13.1 Defective Display and Screen Quality	.....	34
13.2 Screen and Other Appearance	.....	35
14. Reliability Test	.....	36
15. Packing Specifications	.....	38
16. Handling Instruction		
16.1 Cautions for Handling LCD panels	.....	39
16.2 Precautions for Handling	.....	40
16.3 Precautions for Operation	.....	40
16.4 Storage Condition for Shipping Cartons	.....	41
16.5 Precautions for Peeling off the Protective film	.....	42
16.6 Warranty	.....	42
APPENDIX	.....	43

## 1. Application

This Specification is applicable to 108.5mm (4.3 inch) Blanview TFT-LCD monitor with Touch Panel for non-military use.

- ◎ TOPPAN makes no warranty or assume no liability that use of this Product and/or any information including drawings in this Specification by Purchaser is not infringing any patent or other intellectual property rights owned by third parties, and TOPPAN shall not grant to Purchaser any right to use any patent or other intellectual property rights owned by third parties. Since this Specification contains TOPPAN's confidential information and copy right, Purchaser shall use them with high degree of care to prevent any unauthorized use, disclosure, duplication, publication or dissemination of TOPPAN's confidential information and copy right.
- ◎ If Purchaser intends to use this Products for an application which requires higher level of reliability and/or safety in functionality and/or accuracy such as transport equipment (aircraft, train, automobile, etc.), disaster-prevention/security equipment or various safety equipment, Purchaser shall consult TOPPAN on such use in advance.
- ◎ This Product shall not be used for application which requires extremely higher level of reliability and/or safety such as aerospace equipment, telecommunication equipment for trunk lines, control equipment for nuclear facilities or life-support medical equipment.
- ◎ It must be noted as an mechanical design manner, especial attention in housing design to prevent arcuation/flexure caused by stress to the LCD module shall be considered.
- ◎ TOPPAN assumes no liability for any damage resulting from misuse, abuse, and/or miss-operation of the Product deviating from the operating conditions and precautions described in the Specification.
- ◎ It shall be mutually conferred if nonconforming defect which result from unspecified cause in this specification arises.
- ◎ If any issue arises as to information provided in this Specification or any other information, TOPPAN and Purchaser shall discuss them in good faith and seek solution.
- ◎ TOPPAN assumes no liability for defects such as electrostatic discharge failure occurred during peeling off the protective film or Purchaser's assembly process.
- ◎ This Product is compatible for RoHS(2.0) directive.

Object substance	Maximum content [ppm]
Cadmium and its compound	100
Hexavalent Chromium Compound	1000
Lead & Lead compound	1000
Mercury & Mercury compound	1000
Polybrominated biphenyl series (PBB series)	1000
Polybrominated biphenyl ether series (PBDE series)	1000
Bis(2-ethylhexyl)phthalate series(DEHP series)	1000
Butyl benzyl phthalate series(BBP series)	1000
Dibutyl phthalate series(DBP series)	1000
Diisobutyl phthalate series(DIBP series)	1000

2. Outline Specifications

2.1 Features of the Product

- 4.3 inch diagonal display, 480 x RGB [H] x 800 [V] dots.
- 24bitRGB ( 8-8-8 Format ) / 16.7 Million colors.
- MIPI DSI as high-speed interface. Video mode only.
- Timing generator [TG], Counter-electrode driving circuitry, Built-in power supply circuit.
- Long life & High bright white LED back-light.
- Blanview TFT-LCD, improved outdoor readability.
- Monitor with capacitive touch panel.
- Moisture/Water Compensation. Glove Support.

\* MIPI : Mobile Industrial Processor Interface , DSI : Display Serial Interface

	Indoor		Outdoor	
	Readability	Power Efficiency (Battery Life)	Readability	Power Efficiency (Battery Life)
Transmissive	Good	Good	Fair	Poor
Transflective	Fair	Poor	Good	Good
Blanview	Good	Good	Good	Good

2.2 Display Method

Items	Specifications	Remarks
Display type	VA 16.7 Million colors. Blanview, Normally black.	
Driving method	a-Si TFT Active matrix. Line-scanning, Non-interlace.	
Dot arrangement	RGB stripe arrangement.	Refer to "Dot arrangement"
Signal input method	MIPI DSI 2-lanes : 2 data lanes and 1 clock lane	
Backlight type	Long life & High bright white LED.	
Touch panel	capacitive touch panel.	

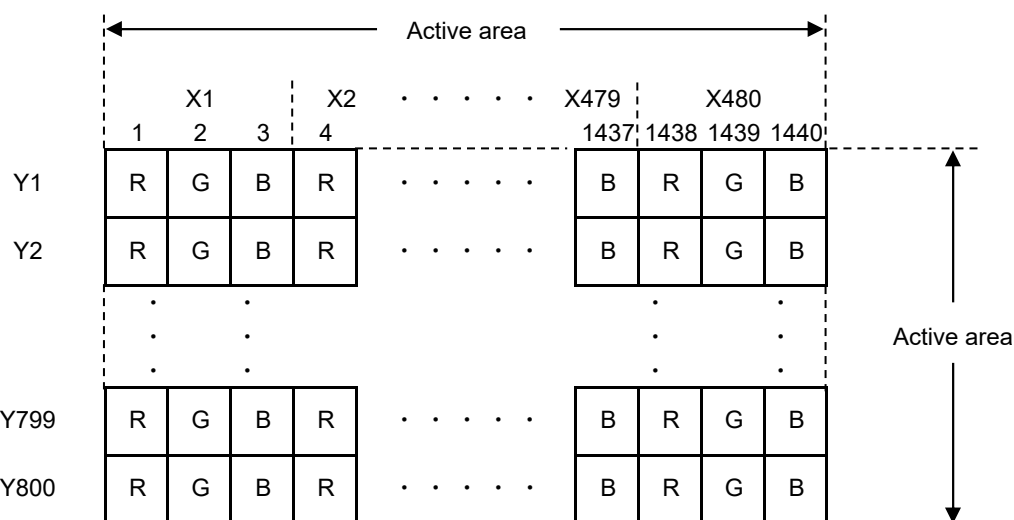

Dot arrangement(FPC is rightside.)



<Features of Blanview>

- Backlight power consumption required to assure visibility. (equivalent to 3.5"QVGA )

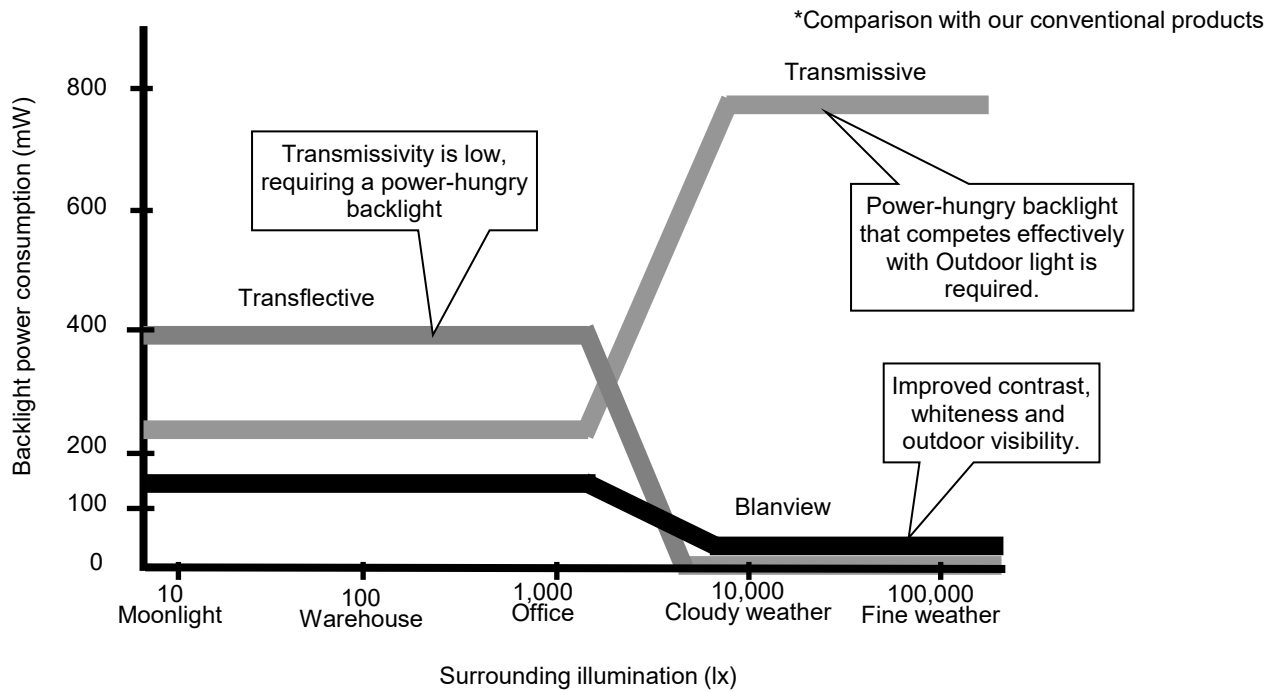

- Contrast characteristics under 100,000lx. (same condition as direct sunlight.)

With better contrast (higher contrast ratio), Blanview TFT-LCD has the best outdoor readability in three different types of TFT-LCD.

Below chart shows contrast value against panel surface brightness. (Horizontal: Panel surface brightness/ Vertical: Contrast value) LCD panel has enough outdoor readability above our Standard line. (TOPPAN criteria)

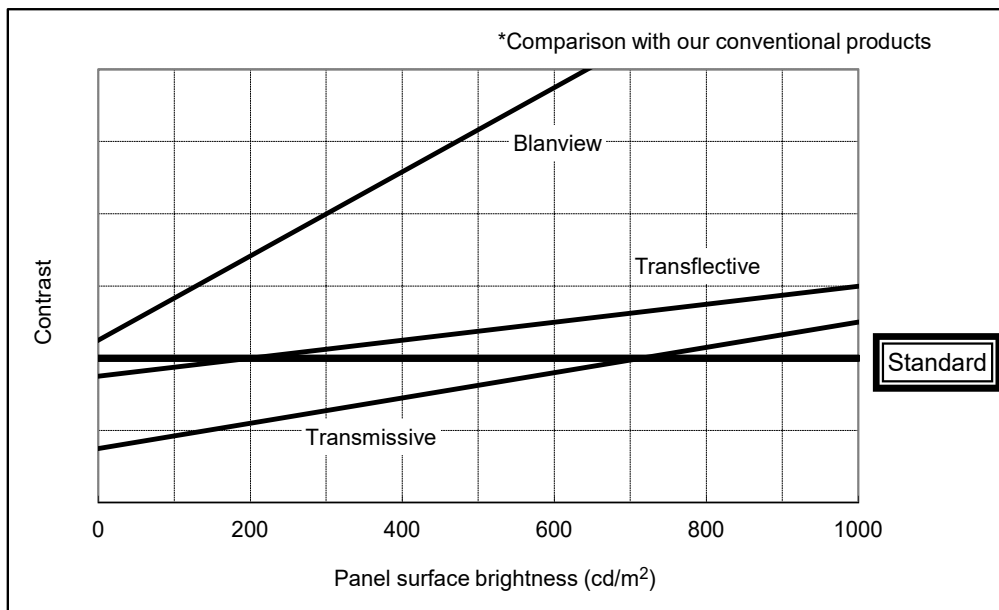

## 3. Dimensions and Shape

## 3.1 Dimensions

Items	Specifications	Unit	Remarks
Outline dimensions	71.20 [H]×117.64 [V]×3.50 [D]	mm	Exclude FPC and parts on FPC
Active area	55.8[H]×93.0[V]	mm	
Number of dots	1440[H]×800[V]	dot	
Dot pitch	38.75[H]×116.25 [V]	um	
Surface hardness of the cover glass	9	H	
Weight	53	g	Include FPC cable



3.2 Outward form

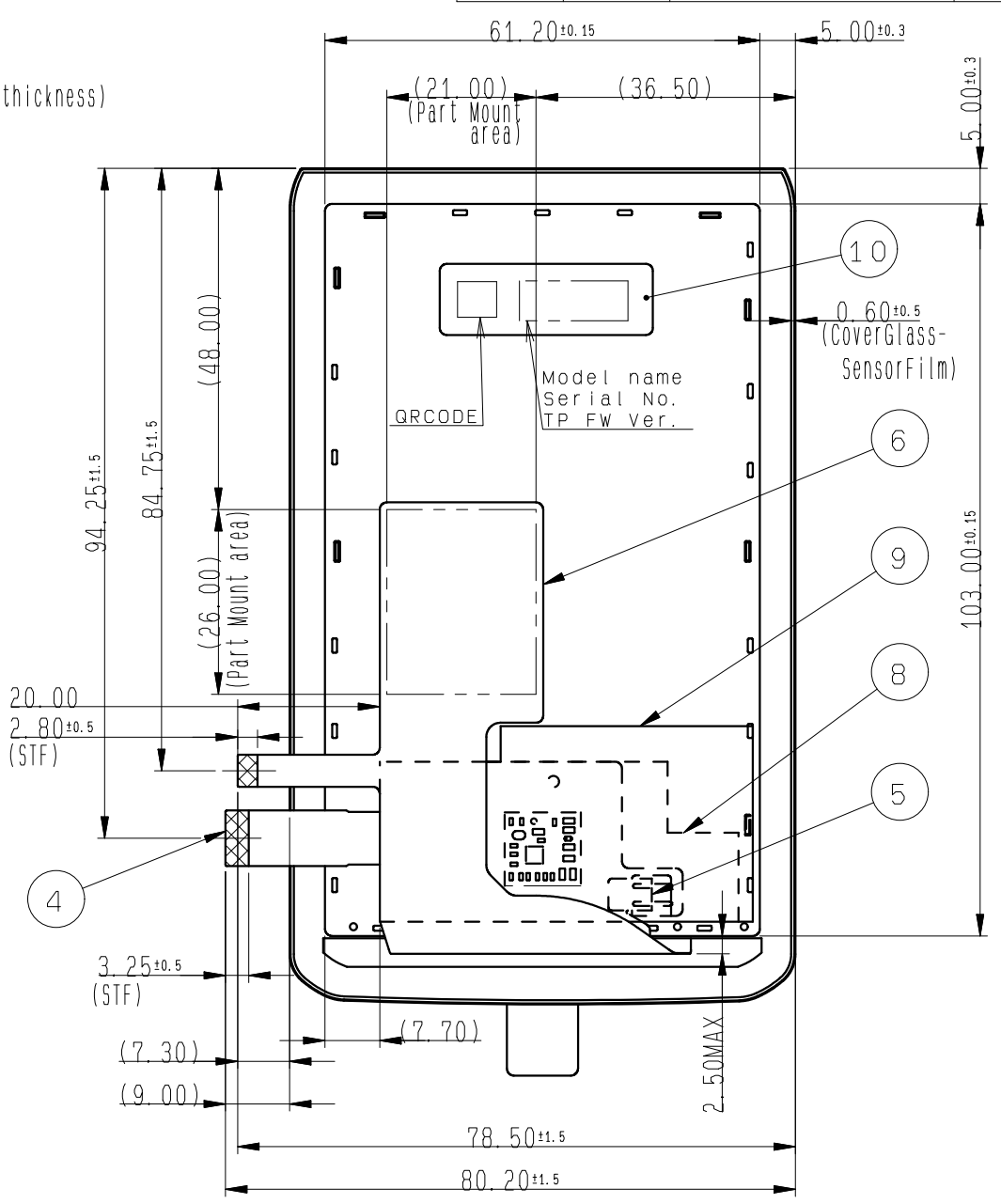
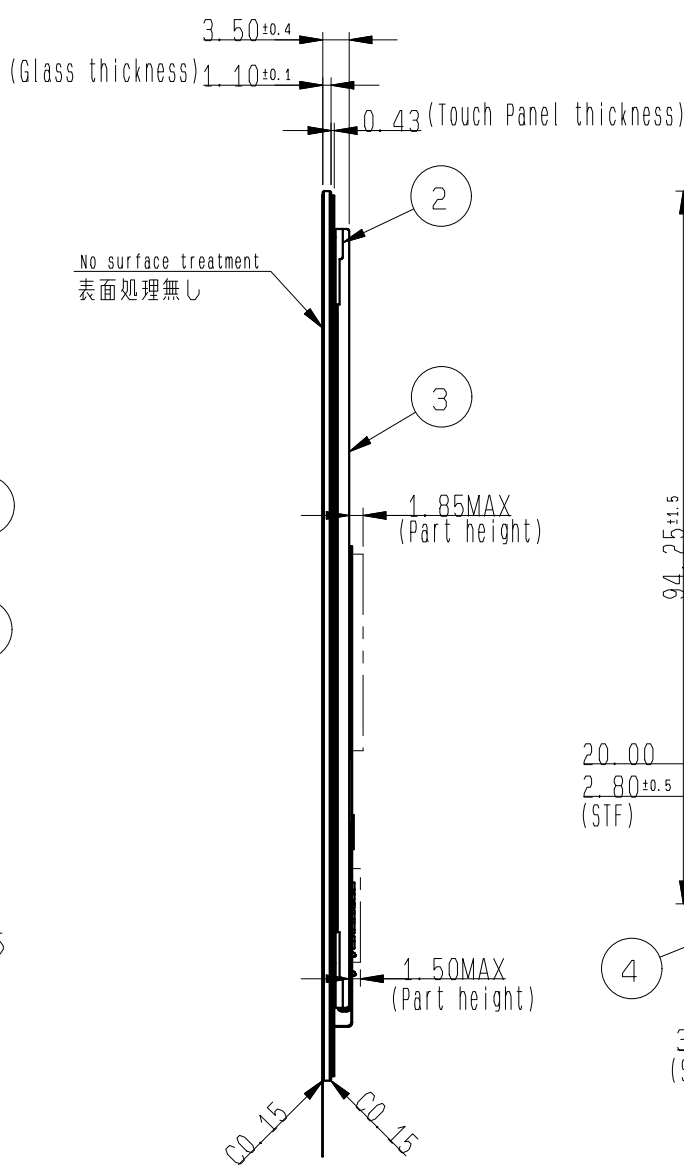
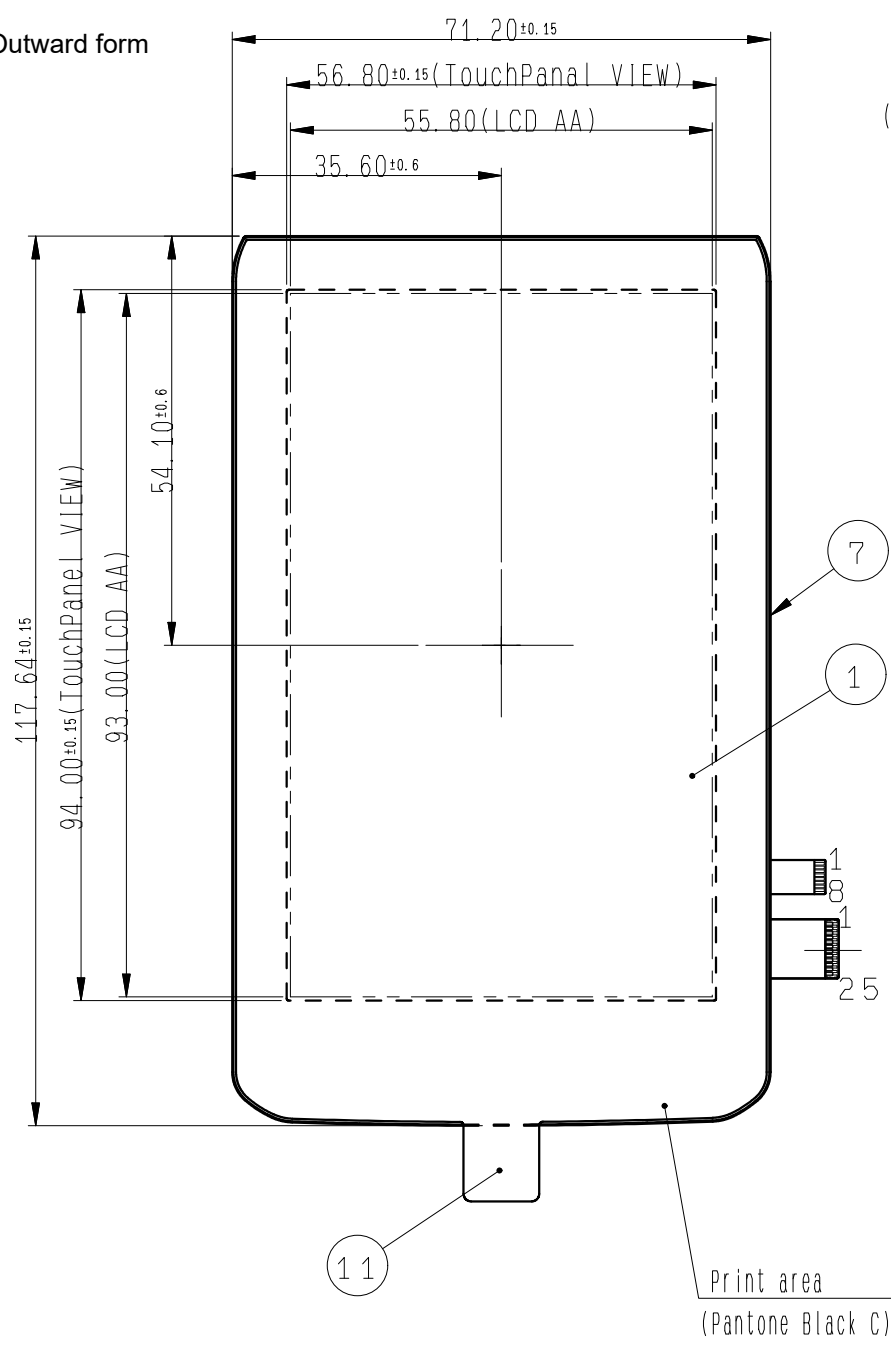

(8/45)  
21TLM016  
Issue: Jun.15,2023

PROTECTIVE FILM	11			
SERIAL LABEL	10			(10x30x0.075t)
TAPE	9			Conductive type
TAPE	8			Isolation type
TOUCH PANEL	7			GFF type(CoverGlass:Soda Glass)
FPC C	6			For TP
FPC B	5			For LED
FPC A	4			For LCD
S CASE C	3			SUS
FRAME	2			PC
TFT-LCD PANEL	1			Glass thickness=0.2t±0.2t

Note 1. Recommended FPC connector.

For LCD : HIROSE, part number:FH35C-25S-0.3SHW(50)  
For TP : HIROSE, part number:FH34SRJ-8S-0.5SH

Note 2. FPC pin assignment differs from a position of Datum Pin of recommended FPC connector.

Note 3. A SERIAL LABEL is affixed the area as shown in the drawing.  
The thickness of SERIAL LABEL will be added to that of S CASE C's surface.

注 1. 推奨FPCコネクタ。  
LCD用 : HIROSE, 型番:FH35C-25S-0.3SHW(50)  
TP用 : HIROSE, 型番:FH34SRJ-8S-0.5SH

注 2. FPCのピン番号とコネクタのピン番号は異なります。

注 3. SERIAL LABELは図の位置に貼り付けられます。  
SERIAL LABELはS CASE C表面よりラベル厚み分、凸形状になります。

APPROVED 尾木幹生	GENERAL TOLERANCE ±0.5	SCALE 1/1	UNIT mm	<b>TOPPAN</b> TOPPAN INC. DO NOT DUPLICATE, CONFIDENTIAL AND PROPRIETARY
CHECKED 木下大輔	ISSUE (Y:M:D) 21:01:05	MODEL COM43H4N98U**		
CHECKED	NAME			DRAWING No.
DESIGN 伊藤宗樹	OUTLINE-D4N98			REV.
DRAW 伊藤宗樹				SHEET
				DIV.
				RJD601236D301 # /



### 3.3 Serial Label (S-label)

#### 3.3.1 Display Items

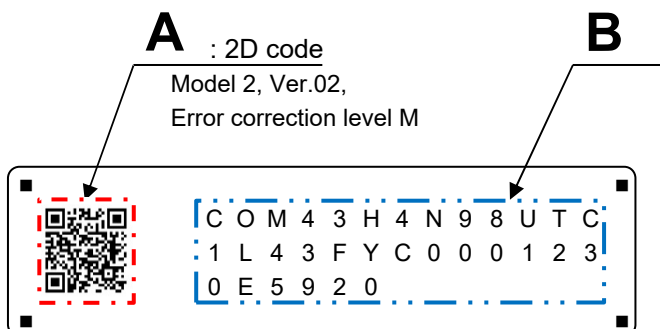

#### 1) Detail "A" Data code explanation

1	~	13	14	15	~	27	28	29	~	34
B: Upper			B: Middle				B: Lower			

14, 28 : Blank

#### 2) Detail "B" character code explanation

Upper content                    COM43H4N98UTC

Middle content Example       1 L 43FYC 000123  
    | |     |     |  
    a b    c     Serial number

Lower content Example        0E5920  
    |  
    TP IC FW Ver. (6 digits)

	Content	Remarks
a	Last number at "A.D." Example) A.D. 2020 → 0	
b	The month that manufactures products	Jan. - A
		Feb. - B
		Mar. - C
		Apr. - D
		May - E
		Jun. - F
		Jul. - G
		Aug. - H
		Sep. - I
		Oct. - J
		Nov. - K
		Dec. - L
c	Model code (5 digits)	43FYC
	Serial number (6 digits)	000001~

#### 3.3.2 Location of Serial Label (S-label)

Refer to 3.2 "Outward Form".

#### 3.3.3 Others

2D code readability is excluded from quality assurance coverage.

## 4. Pin Assignment

## LCD FPC

No.	Symbol	Details	Remark
1	GND	Ground	
2	LED-	Backlight LED Cathode	
3	LED+	Backlight LED Anode	
4	VDD	VDD Power Supply	VDD = 3.3V (TYP)
5	VDD	VDD Power Supply	VDD = 3.3V (TYP)
6	GND	Ground(PVSS)	
7	VCCIO	DSI and I/O Power Supply	VCCIO = 1.8V (TYP)
8	TEST 4	TEST Pim	Please connect to GND.
9	TEST 3	TEST Pim	Please connect to GND.
10	ID1	ID check	Output level is GND.
11	ID2	ID check	Output level is GND.
12	TEST 1	TEST Pim	Please connect to VCCIO(1.8V).
13	TEST 2	TEST Pim	Please connect to VCCIO(1.8V).
14	GND	Ground	
15	RESETB	LCD Reset	L:Initialize Power_ON Reset is Required when Turning on the Power
16	GND	Ground	
17	DSI_D0P	MIPI-DSI Data differential signal input pin	
18	DSI_D0N	MIPI-DSI Data differential signal input pin	
19	GND	Ground	
20	DSI_CN	MIPI-DSI Clock differential signal input pin	
21	DSI_CP	MIPI-DSI Clock differential signal input pin	
22	GND	Ground	
23	DSI_D1P	MIPI-DSI Data differential signal input pin	
24	DSI_D1N	MIPI-DSI Data differential signal input pin	
25	GND	Ground	

- Recommended connector: HIROSE : FH35C-25S-0.3SHW(50)
- Please make sure to check a consistency between pin assignment in "3.2 Outward Form" and your connector pin assignment when designing your circuit.  
Inconsistency in input signal assignment may cause a malfunction.
- Since FPC cable has gold plated terminals, gilt finish contact shoe connector is recommended.

## TP\_FPC

No.	Symbol	Details	Remark
1	GND	Ground	
2	RSTN (1.8V)	External hardware reset input	I/O Signal Voltage = 1.8V (TYP)
3	I2C_INT (1.8V)	Interrupt output	I/O Signal Voltage = 1.8V (TYP)
4	GND	Ground	
5	I2C_SCL (1.8V)	I2C interface, clock input	I/O Signal Voltage = 1.8V (TYP)
6	I2C_SDA (1.8V)	I2C interface, data input	I/O Signal Voltage = 1.8V (TYP)
7	GND	Ground	
8	I2C_VDD	3.3V input power supply	I2C_VDD = 3.3V (TYP)

- Recommended connector: HIROSE : FH34SRJ-8S-0.5SH
- Please make sure to check a consistency between pin assignment in "3.2 Outward Form" and your connector pin assignment when designing your circuit.  
Inconsistency in input signal assignment may cause a malfunction.
- Since FPC cable has gold plated terminals, gilt finish contact shoe connector is recommended.

## 5. Absolute Maximum Rating

GND=0V

Item	Symbol	Condition	Rating		Unit	Applicable terminal
			MIN	MAX		
LCD Supply voltage	VDD	Ta=25 °C	-0.3	4.6	V	VDD
LCD DSI and I/O Supply voltage	VCCIO		-0.3	4.6	V	VCCIO
LCD Input voltage for logic	LCD_VI		-0.3	VCCIO+0.3	V	RESETB, TEST1-4
LCD DSI Input voltage	VDSIIN		-0.15	1.45	V	DSI_D0P/N , DSI_D1P/N DSI_CP/N
TP Supply voltage	I2C_VDD	Ta=25 °C	-0.3	3.6	V	I2C_VDD
LED forward current	IL	Ta=25 °C	-	35	mA	LED+ - LED-
		Ta=70 °C	-	15		
Storage temperature range	Tstg		-30	80	°C	
Storage humidity range	Hstg	Non condensing in an environmental moisture at or less than 40 °C 90%RH.				



## 6. Recommended Operating Conditions

GND=0V

Item	Symbol	Condition	Rating			Unit	Applicable terminal
			MIN	TYP	MAX		
LCD Supply voltage	VDD		2.7	3.3	3.6	V	VDD
LCD DSI and I/O Supply voltage	VCCIO		1.7	1.8	1.9	V	VCCIO
LCD Input voltage for logic	LCD_VI		0	-	VCCIO	V	RESETB, TEST1-4
LCD DSI Input voltage	VDSIIN		-0.05	-	1.35	V	DSI_D0P/N DSI_D1P/N DSI_CP/N
TP Supply voltage	I2C_VDD		3.0	3.3	3.46	V	I2C_VDD
(IC internal power supply)	VIO18		1.7	1.8	1.9	V	
TP Input voltage for logic	TP_VI		0	-	VIO18	V	RSTN, I2C_INT, I2C_SCL, I2C_SDA
Operational temperature range	Top	Note1,2	-20	25	70	°C	Panel surface temperature
Operating humidity range	Hop	Ta<=40 °C	20	-	85	%	
		Ta>40 °C	Non condensing in an environmental moisture at or less than 40 °C 85%RH.				

Note1: This monitor is operatable in this temperature range. With regard to optical characteristics, refer to Item 12."CHARACTERISTICS".

Note 2: Acceptable Forward Current to LED is up to 15 mA, when Ta=+70 °C.  
Do not exceed Allowable Forward Current shown on the chart below.

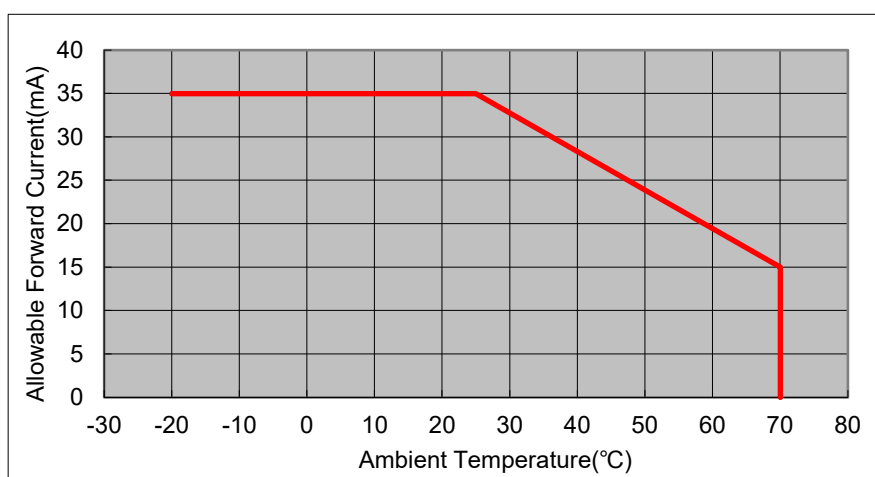

## 7. Electrical Characteristics

## 7.1 DC Characteristics

## 7.1.1 LCD Display Module

(Unless otherwise noted, Ta=25 °C,VDD=I2C\_VDD=3.3V,VCCIO=1.8V,GND=0V)

Item	Symbol	Condition	Rating			Unit	Applicable terminal
			MIN	TYP	MAX		
Input Signal Voltage	LCD_VIH	VCCIO=1.7-1.9V	0.7×VCCIO	-	VCCIO	V	RESETB
	LCD_VIL		0	-	0.3×VCCIO	V	TEST1-4
Operating Current	IDD	fDSICLK=150 MHz	-	12.4	24.8	mA	VDD
	ICCIO	Color bar display	-	3.2	6.4	mA	VCCIO
Sleep_mode Current	IDDS	Clock/Data=LP11	-	42	100	uA	VDD
	ICCIOS	Sleep_mode	-	10	100	uA	VCCIO

## 7.1.2 TP Module

(Unless otherwise noted, Ta=25 °C,VDD=I2C\_VDD=3.3V,VCCIO=1.8V,GND=0V)

Item	Symbol	Condition	Rating			Unit	Applicable terminal
			MIN	TYP	MAX		
Input Signal Voltage	TP_VIH	VIO18=1.8V	0.6×VIO18	-	VIO18	V	RSTN,
	TP_VIL		0	-	0.3×VIO18	V	I2C_SCL, I2C_SDA
Output Signal Voltage	TP_VOH	Io=8mA	0.7×VIO18	-	VIO18	mA	I2C_INT,
	TP_VOL	Io=-10mA	0	-	0.3×VIO18	mA	I2C_SCL, I2C_SDA
Operating Current	I2C_IDD	1 touch at center. *for reference	-	70	-	mA	I2C_VDD

(VIO18=1.8V ; IC internal power supply)

## 7.1.3 MIPI DSI Interface

Item	Symbol	Condition	Rating			Unit	Note
			MIN	TYP	MAX		
HS-RX	Differential input high threshold	VIDTH	-	-	110	mV	
	Differential input low threshold	VIDTL	-110	-	-	mV	
	Single-ended input high voltage	VIHHS	-	-	460	mV	
	Single-ended input low voltage	VILHS	-40	-	-	mV	
	Common-mode voltage HS receive mode	VCMRXDC	70	-	330	mV	
	Differential input impedance	ZID	80	100	125	Ohm	
LP-RX	Logic 1 input voltage	VIH	880	-	-	mV	
	Logic 0 input voltage	VIL	-	-	550	mV	
LP-TX	Thevenin output low level	VOL	-50	-	50	mV	
	Thevenin output high level	VOH	1.1	1.2	1.3	V	
	Output impedance of LP transmitter	ZOLP	110	-	-	Ohm	
CD-RX	Logic 1 contention threshold	VIHCD	450	-	-	mV	
	Logic 0 contention threshold	VILCD	-	-	220	mV	

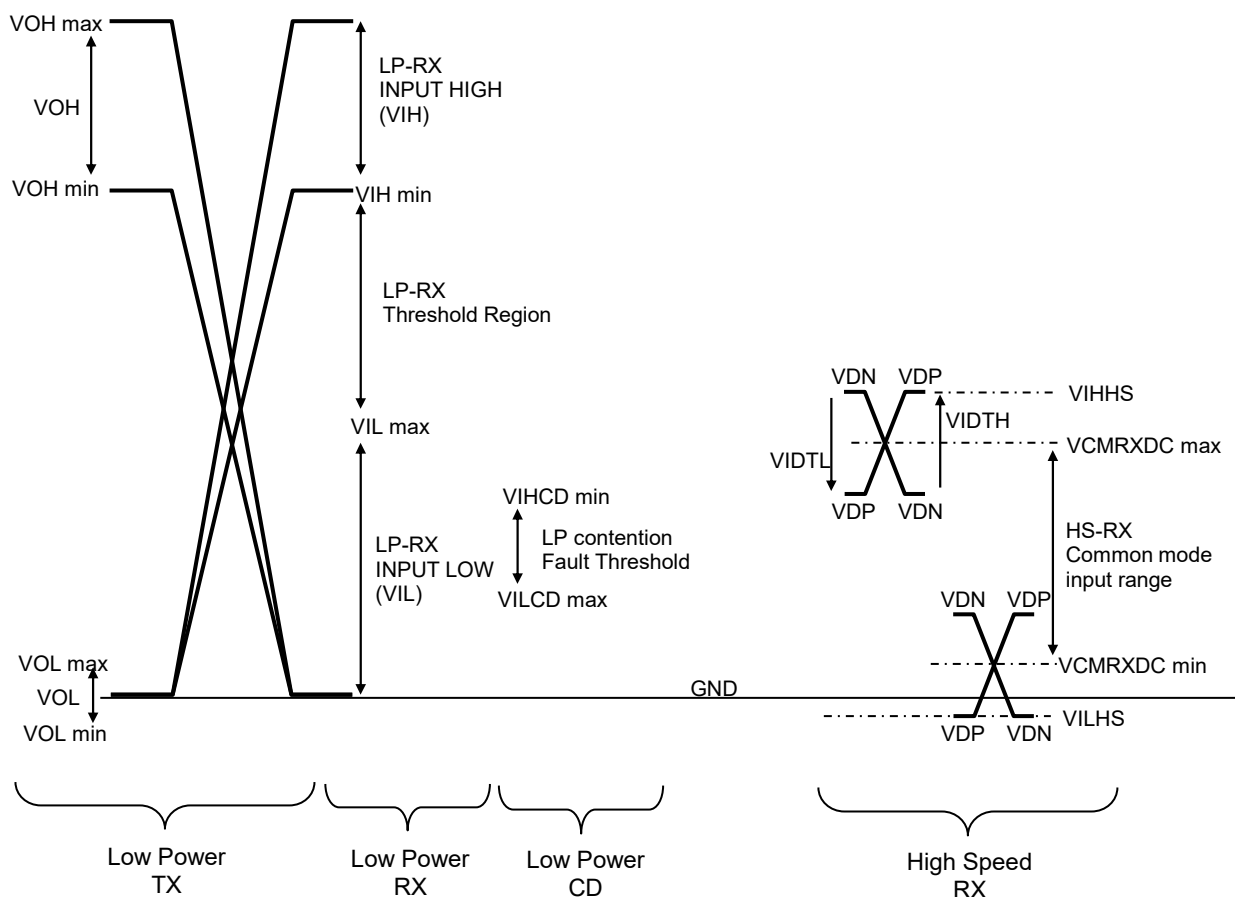

The signal levels for the LP and HS .

#### 7.1.4 Backlight

Item	Symbol	Condition	Rating			Unit	Applicable terminal
			MIN	TYP	MAX		
Forward current	IL25	Ta=25 °C	--	7.0	35	mA	LED+ - LED-
	IL70	Ta=70 °C	--	--	15	mA	
Forward voltage	VL	Ta=25 °C IL=7 mA	--	18.9	21.0	V	*Reference only
Estimated Life of LED	LL	Ta=25 °C, IL=7.0mA Note	--	20,000	--	hrs	

Note: - The lifetime of the LED is defined as a period till the brightness of the LED decreases to the half of its initial value.

- This figure is given as a reference purpose only, and not as a guarantee.

- This figure is estimated for an LED operating alone.

As the performance of an LED may differ when assembled as a monitor together with a TFT panel due to different environmental temperature.

- Estimated lifetime could vary on a different temperature and usually higher temperature could reduce the life significantly.



## 7.2 AC Characteristics

## 7.2.1 HS-RX Specifications

(Unless otherwise noted,  $T_a=25\text{ }^\circ\text{C}$ ,  $V_{DD}=I2C\_VDD=3.3\text{V}$ ,  $V_{CCIO}=1.8\text{V}$ ,  $GND=0\text{V}$ )

Item	Symbol	Rating			Unit	Applicable terminal
		MIN	TYP	MAX		
DSICLK Frequency	$f_{\text{DSICLK}}$	40	-	200	MHz	DSI_CP/N
DSICLK Cycle time	TCLKP	5.0	-	25.0	ns	
DSI Data Transfer Rate	UI	2.5	-	12.5	ns	DSI_D0P/N , DSI_D1P/N
	$t_{\text{DSIR}}$	80	-	400	Mbps	
Data to Clock Setup Time	Tsetup	0.35	-	-	UI	DSI_D0P/N , DSI_D1P/N
Clock to Data Hold Time	Thold	0.25	-	-	UI	DSI_CP/N

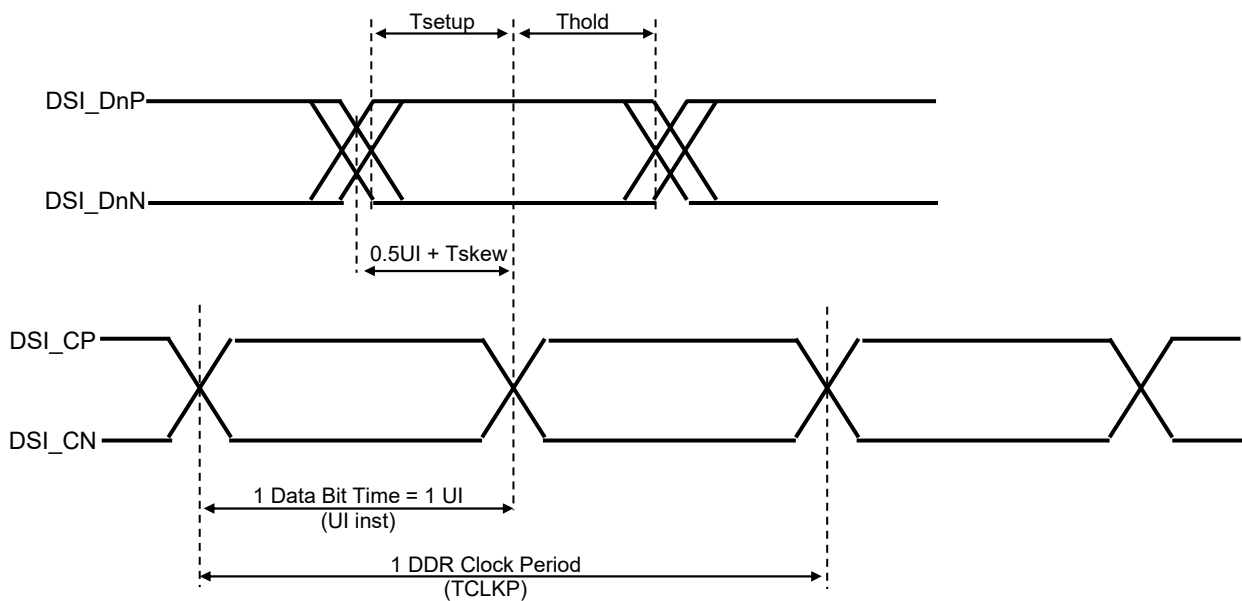

Data to Clock Timing Definitions

## 7.2.2 LP-TX Specifications

(Unless otherwise noted,  $T_a=25\text{ }^\circ\text{C}$ ,  $V_{DD}=I2C\_VDD=3.3\text{V}$ ,  $V_{CCIO}=1.8\text{V}$ ,  $GND=0\text{V}$ )

Item	Symbol	Condition	Rating			Unit	Applicable terminal
			MIN	TYP	MAX		
15% - 85% rise time	TRLP		-	-	25	ns	DSI_D0P/N
85% - 15% fall time	TFLP		-	-	25	ns	DSI_D0P/N
Slew rate	$\Delta v / \Delta t_{\text{SR}}$	Cl <sub>load</sub> = 70pF	30	-	500	mV/ns	DSI_D0P/N

## 7.2.3 RX/TX Specifications

(Unless otherwise noted,  $T_a=25\text{ }^\circ\text{C}$ ,  $V_{DD}=I2C\_VDD=3.3\text{V}$ ,  $V_{CCIO}=1.8\text{V}$ ,  $GND=0\text{V}$ )

Item	Description	Rating			Unit
		MIN	TYP	MAX	
$T_{HS-PREPARE}$	Time to drive LP00 to prepare for HS transmission	40 ns + 4UI	-	85 ns + 6UI, $\leq 100$ ns	
$T_{HS-PREPARE} + T_{HS-ZERO}$	$T_{HS-PREPARE}$ + Time to drive HS0 before the SYNC sequence	145 ns + 10UI	-	-	
$T_{HS-TRAIL}$	Time to drive flipped differential state after last payload data bit of a HS transmission burst	$\max(n*8\text{UI}, 60\text{ ns} + n*4\text{UI})$	-	-	
$T_{HS-EXIT}$	Time to drive LP11 after HS burst	100	-	-	ns
$T_{TA-GO}$	Time to drive LP00 after Turnaround Request	$4*T_{LPTX}$			
$T_{TA-SURE}$	Time out before new TX side starts driving	$T_{LPTX}$	-	$2*T_{LPTX}$	
$T_{TA-GET}$	Time to drive LP00 by new TX	$5*T_{LPTX}$			
$T_{LPX}$	Length of any Low Power state period	50	-	-	ns
Ratio $T_{LPX}$	Ratio of $T_{LPX}(\text{MASTER})/T_{LPX}(\text{SLAVE})$ between Master and Slave side	2/3	-	3/2	
$T_{CLK-POST}$	Time that the transmitter shall continue sending HS clock after the last associated Data Lane has transitioned to LP mode	60 ns + 52UI	-	-	
$T_{CLK-PREPARE} + T_{CLK-ZERO}$	$T_{CLK-PREPARE}$ + time for lead HS-0 drive period before starting Clock	300	-	-	ns
$T_{CLK-PRE}$	Time that the HS clock shall be driven prior to any associated Data Lane beginning the transition from LP to HS mode	8	-	-	UI
$T_{CLK-PREPARE}$	Time to drive LP-00 to prepare for HS clock transmission	38	-	95	ns
$T_{CLK-TRAIL}$	Time to drive HS differential state after last payload clock bit of a HS transmission burst	60	-	-	ns
$T_{EOT}$	Time from start of $T_{HS-TRAIL}$ period to start of LP-11 state	-	-	105 ns + $n*12\text{UI}$	
$T_{LPTX1}$	Length of Low-Power TX state period in case of using DSI clock	-	$n*DSITX$	-	UI
$T_{LPTX2}$	Length of Low-Power TX state period in case of using internal OSC clock	-	1/fosc	-	ns

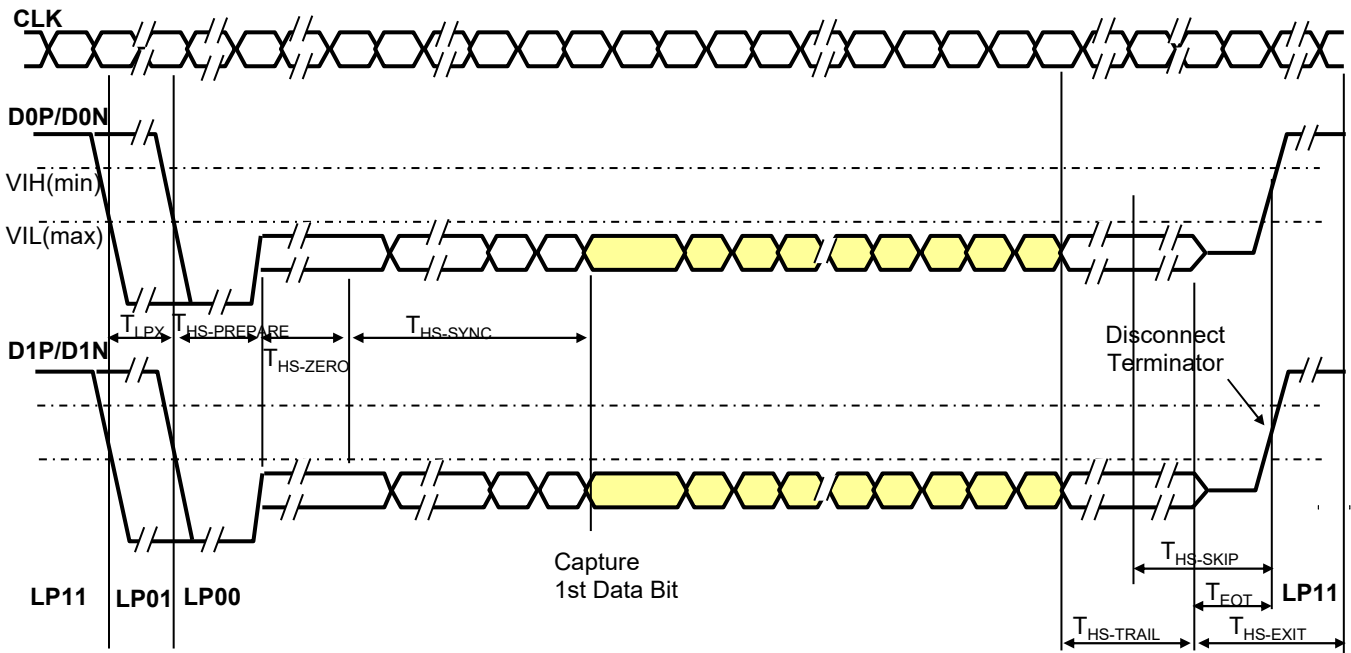

HS Data Transmission in Bursts

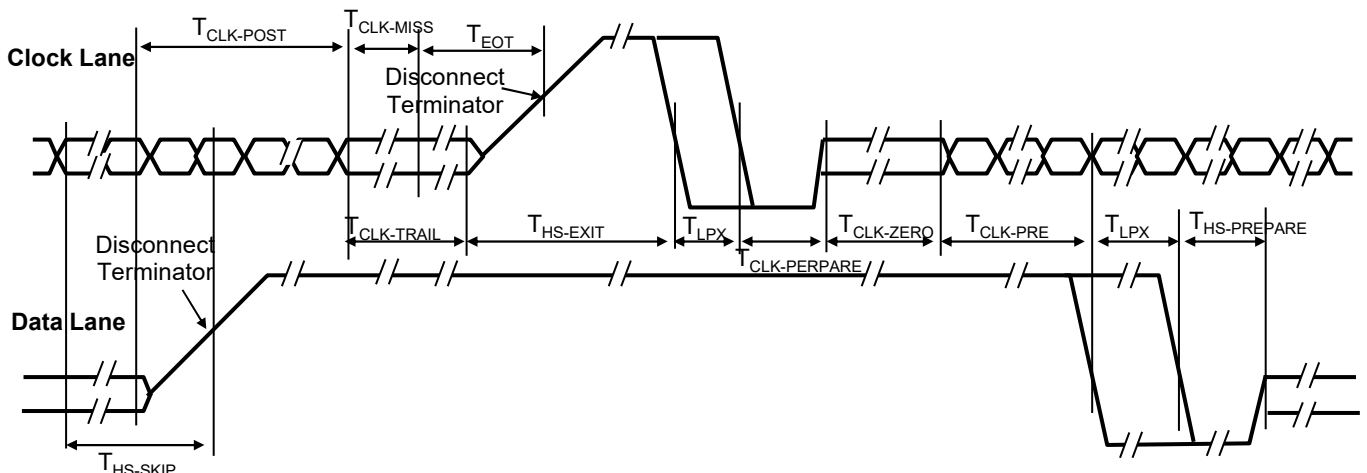

Switching the Clock Lane between Clock Transmission and LP mode

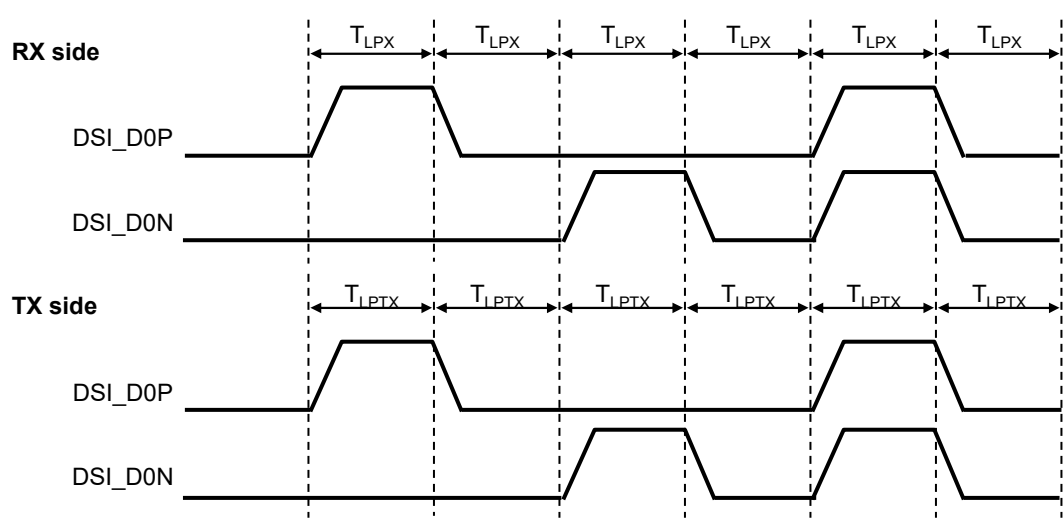

DSI LP Mode

## 7.2.4 LCD Reset input timing

Item	Symbol	Condition	Rating			Unit	Remark
			MIN	TYP	MAX		
Reset Low Pulse width	tRESW		10	-	-	us	
Reset Complete time	tREST	during Sleep In	-	-	5	ms	
		during Sleep Out	-	-	120	ms	

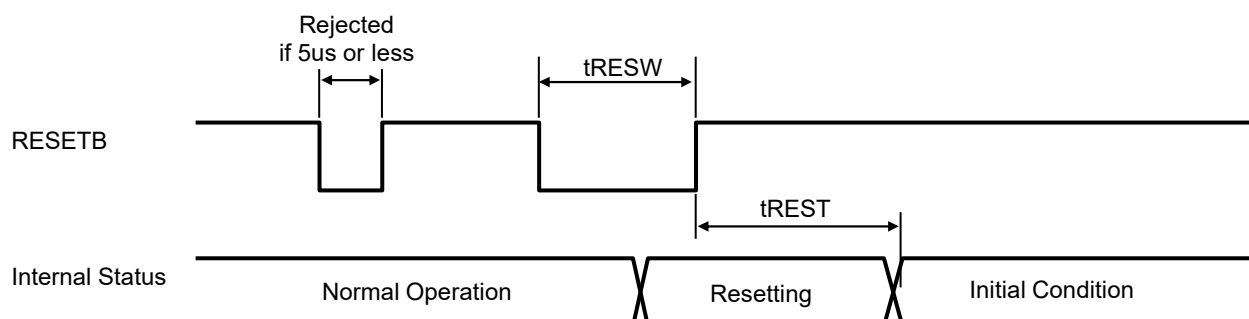

RESETB input timing

## 7.3 LCD Input Timing Characteristics

Item	Symbol	Rating			Unit	Remark
		MIN	TYP	MAX		
CLK Frequency	fPCLK	--	25.0	--	MHz	PCLK
VSYNC Frequency	Note fVSYNC	54.0	57.5	63.2	Hz	VSYNC
VSYNC Cycle	tv	809	824	850	H	
VSYNC Pulse Width	tw4H	3	8	--	H	
Vertical Back Porch	tvb	3	8	--	H	
Vertical Front Porch	tvf	3	8	--	H	
Vertical Display Period	tvdP	800			H	
HSYNC frequency	fHSYNC	47.3			kHz	HSYNC
HSYNC Cycle	th	504	528	568	CLK	
HSYNC Pulse Width	tw5H	5	16	78	CLK	
Horizontal Back Porch	thb	5	16	78	CLK	
Horizontal Front Porch	thf	5	16	78	CLK	
Horizontal data start Point	tw5H+thb	19	32	83	CLK	
Horizontal Blanking Period	tw5H+thb+thf	24	48	88	CLK	
Horizontal Display Period	thdp	480			CLK	

Note: This is recommended spec to get high quality picture on display. It is customer's risk to use out of this frequency.

### 7.4 LCD Input Signal Timing Chart

#### -Vertical Timing

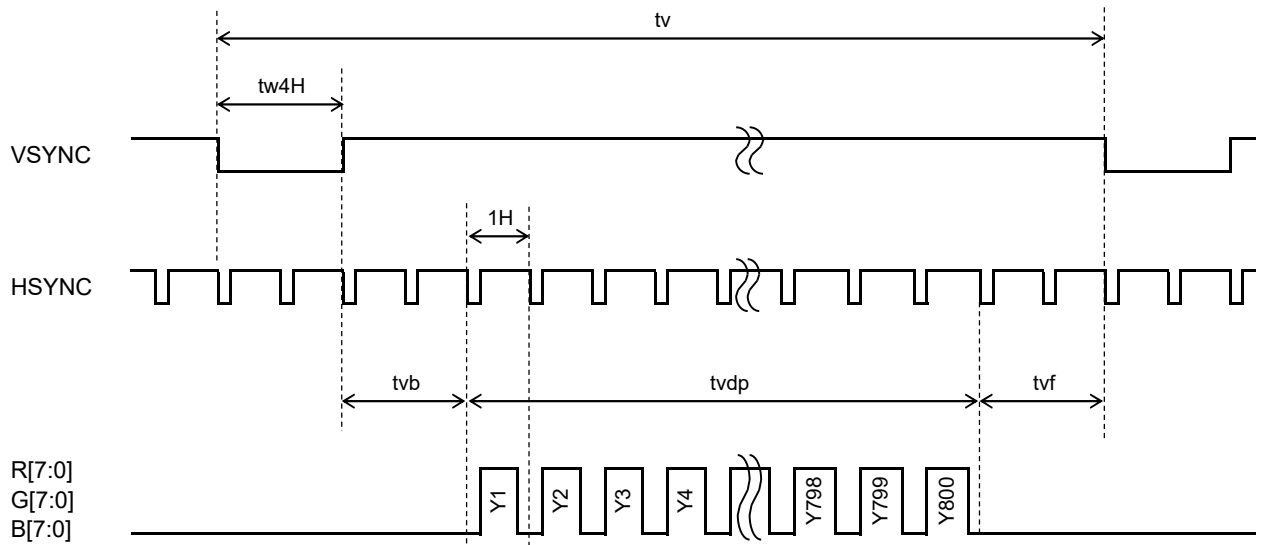

#### -Horizontal Timing

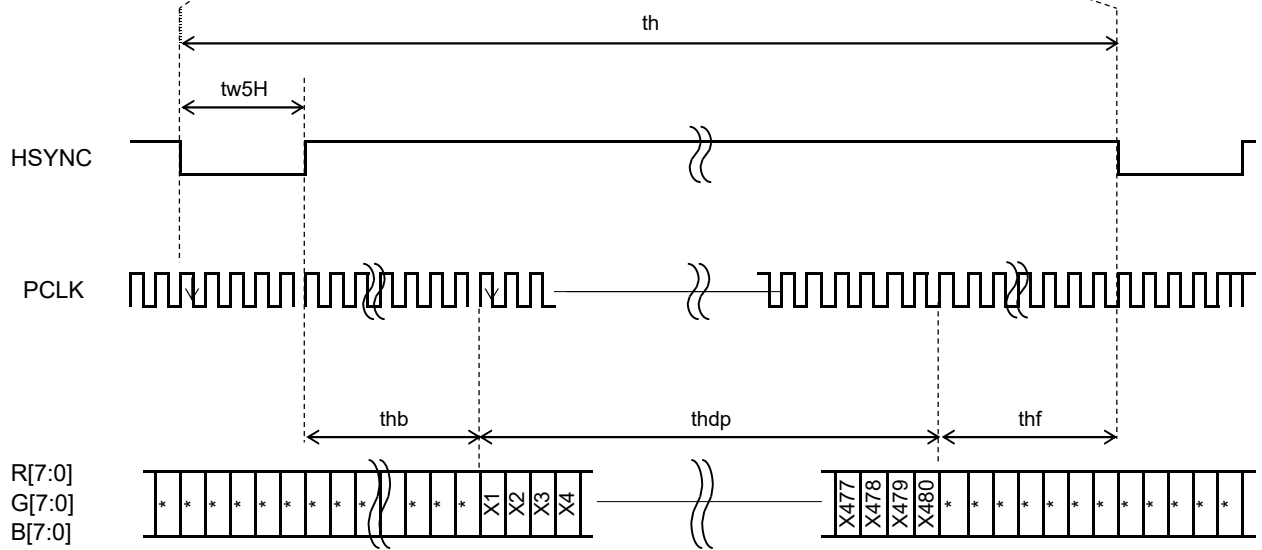

Timing Characteristics of input signals

## 7.5 Touch Panel Characteristics

(Unless otherwise noted, Ta=25 °C, VDD=I2C\_VDD=3.3V, VCCIO=1.8V, GND=0V)

Item	Condition	Rating			Unit	Note
		MIN	TYP	MAX		
Multi-touch points	Fingers	-	6	6	points	Design guarantee
Accuracy		-3.0	-	+3.0	mm	Design guarantee
Accuracy at edge(*)		-4.5	-	+4.5	mm	
Linearity		-2.0	-	+2.0	mm	
Linearity at edge(*)		-3.0	-	+3.0	mm	Design guarantee
Glove Support		-	3	5	mm	Design guarantee
Water Rejection(**)	Liquid size	-	-	10	cc	Design guarantee
Water Touch Operation(**)		-	1	2	points	Design guarantee

(VIO18=1.8V ; IC internal power supply)

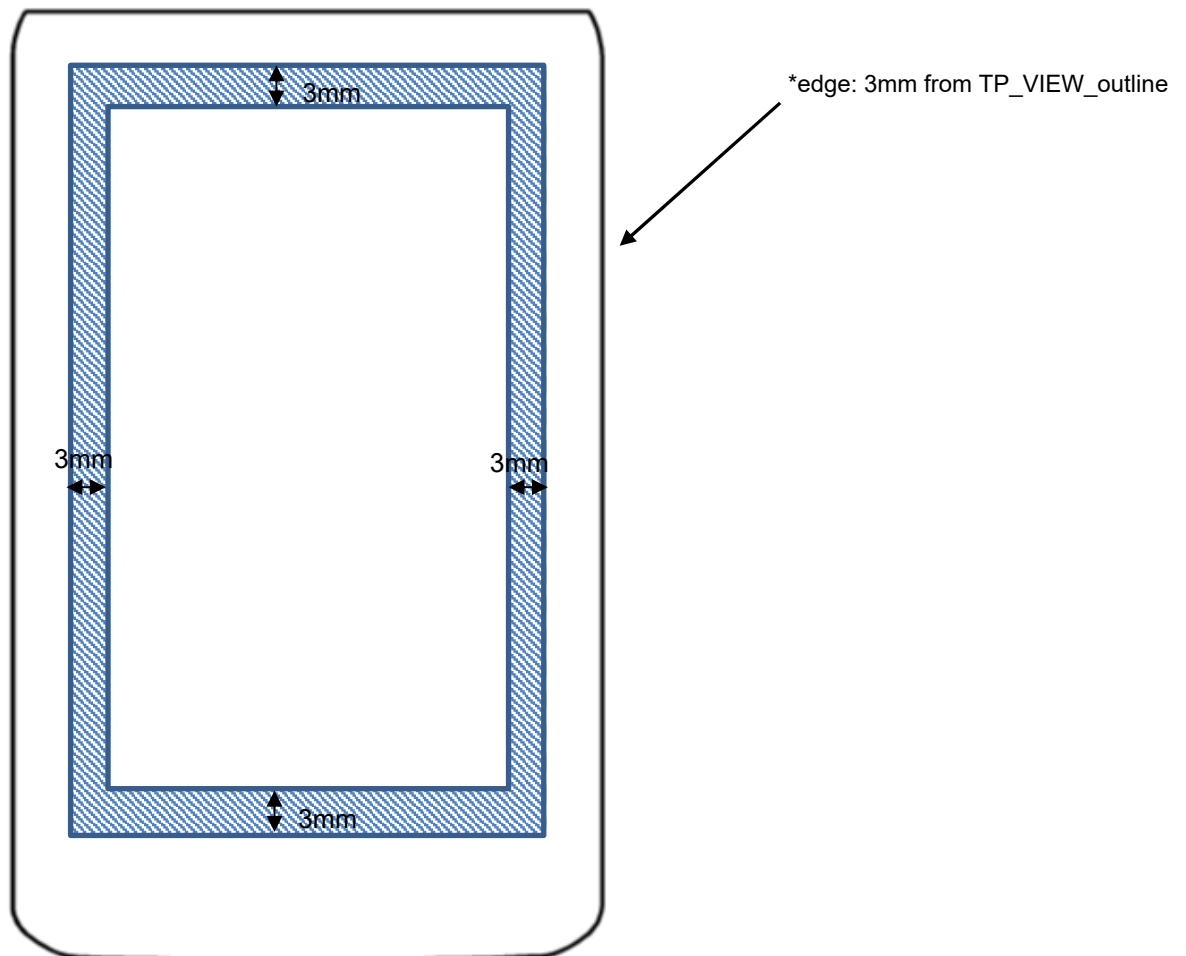

\*\* Moisture/Water Compensation

Liquid	Example	Criteria	Pure Water
Water Mist Or Wet Finger		Water Rejection 30*30mm	O
		2 Finger Touch water area non water area	O O
Water Drops (1cc ~ 2cc)		Water Rejection 30*30mm	O
		1 Finger Touch water area non water area	O O
Water Puddle (10cc)		Water Rejection 30*30mm	O
		1 Finger Touch water area non water area	X O

## 8. About MIPI Interface

### 8.1 Version

The DSI incorporated in the LCD-Driver complies with the following standards.

MIPI DSI : Version 1.01

MIPI D-PHY : Version 1.00

Data transfer mode : Video mode only.

If the DSI\_CLK lane becomes unintentionally at the LP (Low Power) level due to the influence of noise such as ESD, it may malfunction.

As a countermeasure for this, we recommend turning DSI\_CLK OFF (LP) during the blanking period.

Virtual Channel : Set to VC[1:0]=00.

### 8.2 DSI protocol

- Short packets specify the payload length using the Data Type field and are from 2 to 9 bytes in length. Short packets is used for most Command Mode commands and associated parameters.

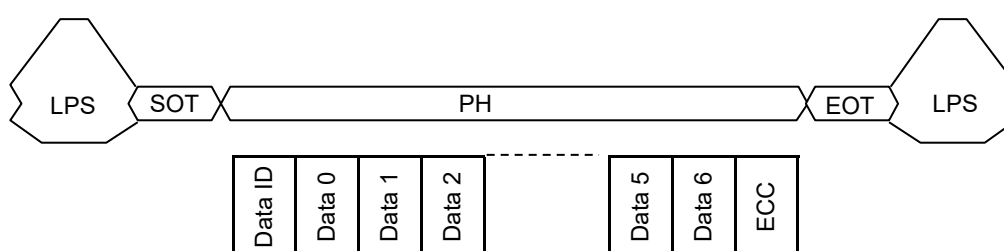

LPS : Low power state

SOT : Start of Transmission

PH : Packet Header

DI(Data ID) : Contain Virtual Channel Identifier and Data Type

ECC : Error Correction Code

- Long packets specify the payload length using a two-byte Word Count field and then the payload maybe 0 to 65,541 bytes in length. Long packets permit transmission of large blocks of pixel or other data.

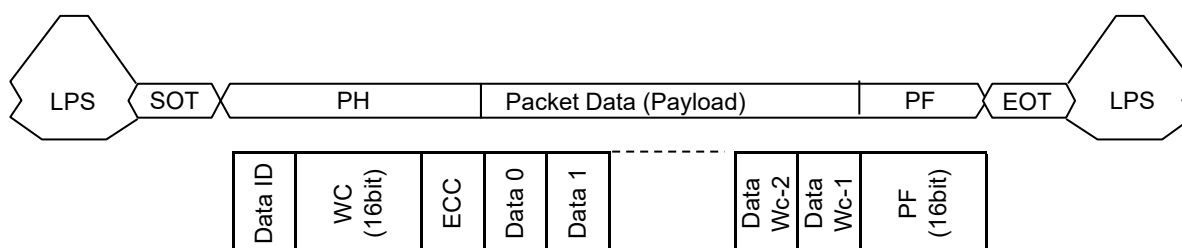

LPS : Low power state

SOT : Start of Transmission

PH : Packet Header

DI(Data ID) : Contain Virtual Channel Identifier and Data Type

WC(Word Count) : The receiver use WC to define packet end.

ECC : Error Correction Code

PF(Packet Footer) : Mean 16-bit Checksum.



### 8.3 Packet data types

LCD-Driver has the following restriction.

Generic short / Long Write Cmd is not supported.

It is only DCS Short / Long Write Cmd.

#### Processor to peripheral direction

Data Type Hex	Description	Size
01 h	Sync Event , V Sync Start (01,00,00,07)	Short
11 h	Sync Event , V Sync End (11,00,00,14)	Short
21 h	Sync Event , H Sync Start (21,00,00,12)	Short
31 h	Sync Event , H Sync End (31,00,00,01)	Short
22 h	Shut Down Peripheral Command (22,00,00,1E)	Short
32 h	Turn On Peripheral Command (32,00,00,0D)	Short
05 h	DCS WRITE , no parameters	Short
15 h	DCS WRITE , one parameters	Short
06 h	DCS READ , no parameters	Short
37 h	Set Maximum Return Packet Size	Short
08 h	End of Transmission Packet (08,0F,0F,01)	Short
09 h	Null Packet , no data	Long
19 h	Blanking Packet , no data	Long
39 h	DCS Long Write Command Packet	Long
0E h	Packed Pixel Stream , 16-bit RGB , 5-6-5 Format	Long
1E h	Packed Pixel Stream , 18-bit RGB , 6-6-6 Format	Long
2E h	Loosely Packed Pixel Stream , 18-bit RGB ,6-6-6 Format	Long
3E h	Packed Pixel Stream , 24-bit RGB , 8-8-8 Format	Long

#### Peripheral to processor direction

Data Type Hex	Description	Size
02 h	Acknowledge with Error Report	Short
1C h	DCS Long READ Response	Long

### 8.4 Packet Footer on the long packet

After Packet Data, Packet Footer is added in Long packet. Packet Footer adds CRC calculated from Packet Data as Checksum.

Checksum(2byte) = CRC(Packet Data)

$CRC = X^{16} + X^{12} + X^5 + X^0$

## 9. Sequence

## 9.1 LCD Power-ON Sequence

PH :Packet Header

PD :Packet Data

PF:Packet Footer (=Checksum)

No.		Function	DNC	Command /Parameter	Type	Command/Parameter
		RESETB=0				
	Power on	VDD, VCCIO on				
	Wait	wait 10 msec or more				
		RESETB=1				
	MIPI signal state	keep CLKN, CLKP, D0N, D0P, D1N, D1P in STOP state (LP-11)				
	Wait	wait 10 msec or more				
1	Sleep out	Sleep out	0	11h	PH	[05 11 00 36]
	Wait	wait 100 msec or more				
2	Enable extended commands	Enable extended commands	0	B9h	PH	[39 04 00 2C]
		Parameter 1	1	FFh	PD	[B9 FF 83 63]
		Parameter 2	1	83h	PF	[XX XX]
		Parameter 3	1	63h		
3	Set lane number/ operation mode	Two data lane, Sync Pulses mode *1	0	BAh	PH	[39, 0E, 00, 15]
		Parameter 1	1	80h	PD	[BA 80 00 10 08 08 10 7E 6E 6D 0A 01 80 43]
		Parameter 2	1	00h	PF	[XX XX]
		Parameter 3	1	10h		
		Parameter 4	1	08h		
		Parameter 5	1	08h		
		Parameter 6	1	10h		
		Parameter 7	1	7Eh		
		Parameter 8	1	6Eh		
		Parameter 9	1	6Dh		
		Parameter 10	1	0Ah		
		Parameter 11	1	01h		
		Parameter 12	1	80h		
		Parameter 13	1	43h		
4	Memory access control	Memory access control	0	36h	PH	[15 36 00 29]
		Parameter 1	1	00h		
5	Interface pixel format	Interface pixel format	0	3Ah	PH	[15 3A 70 28]
		Parameter 1( 24bit/pixel)	1	70h		
	Wait	wait 5 msec or more				
6	Set power	Set power	0	B1h	PH	[39 0D 00 13]
		Parameter 1	1	78h	PD	[B1 78 24 06 02 02 03 10 10 34 3C 3F 3F]
		Parameter 2	1	24h	PF	[XX XX]
		Parameter 3	1	06h		
		Parameter 4	1	02h		
		Parameter 5	1	02h		
		Parameter 6	1	03h		
		Parameter 7	1	10h		
		Parameter 8	1	10h		
		Parameter 9	1	34h		
		Parameter 10	1	3Ch		
		Parameter 11	1	3Fh		
		Parameter 12	1	3Fh		

PH :Packet Header

PD :Packet Data

PF:Packet Footer (=Checksum)

No.		Function	DNC	Command /Parameter	Type	Command/Parameter
7	Set display waveform cycle	Set display waveform cycle	0	B4h	PH	[39 0A 00 36]
		Parameter 1	1	00h	PD	[B4 00 08 6E 07 01 01 5E 01 57]
		Parameter 2	1	08h	PF	[XX XX]
		Parameter 3	1	6Eh		
		Parameter 4	1	07h		
		Parameter 5	1	01h		
		Parameter 6	1	01h		
		Parameter 7	1	5Eh		
		Parameter 8	1	01h		
		Parameter 9	1	57h		
8	Set panel	Set panel	0	CCh	PH	[15 CC 0B 22]
		Parameter 1	1	0Bh		
9	Set gamma curve related setting	Set gamma curve related setting	0	E0h	PH	[39 1F 00 29]
		Parameter 1	1	01h	PD	[E0 01 48 50 4E 58 F6 0B 4E 52 D5 15 95 55 CE 11 01 88 50 55 5F FD 0A 4E 91 D3 17 95 96 8E 11]
		Parameter 2	1	48h		
		Parameter 3	1	50h	PF	[XX XX]
		Parameter 4	1	4Eh		
		Parameter 5	1	58h		
		Parameter 6	1	F6h		
		Parameter 7	1	0Bh		
		Parameter 8	1	4Eh		
		Parameter 9	1	52h		
		Parameter 10	1	D5h		
		Parameter 11	1	15h		
		Parameter 12	1	95h		
		Parameter 13	1	55h		
		Parameter 14	1	CEh		
		Parameter 15	1	11h		
		Parameter 16	1	01h		
		Parameter 17	1	88h		
		Parameter 18	1	50h		
		Parameter 19	1	55h		
		Parameter 20	1	5Fh		
		Parameter 21	1	FDh		
		Parameter 22	1	0Ah		
		Parameter 23	1	4Eh		
		Parameter 24	1	91h		
		Parameter 25	1	D3h		
		Parameter 26	1	17h		
		Parameter 27	1	95h		
		Parameter 28	1	96h		
		Parameter 29	1	8Eh		
		Parameter 30	1	11h		
	Wait	wait 5 msec or more				
10	Display on	Display on	1	29h	PH	[05 29 00 1C]
11	Video stream					...
						...
						...

\*1 The described value is Sync Pulses mode in DSI interface.

If you want to changes the lane number/ operation mode. Please follow the under packet to change it.

Two data lane, Sync Pulses mode :

Packet header [39, 0E, 00, 15],

Packet data [BA 80 00 10 08 08 10 7E 6E 6D 0A 01 80 43],

Packet footer[XX XX]

Two data lane, Sync Events mode/Burst mode :

Packet header [39, 0E, 00, 15],

Packet data [BA 80 00 10 08 08 10 7E 6E 6D 0A 01 84 43],

Packet footer[XX XX]

One data lane, Sync Pulses mode :

Packet header [39, 0E, 00, 15],

Packet data [BA 80 00 10 08 08 10 7E 6E 6D 0A 00 80 43],

Packet footer[XX XX]

One data lane, Sync Events mode/Burst mode :

Packet header [39, 0E, 00, 15],

Packet data [BA 80 00 10 08 08 10 7E 6E 6D 0A 00 84 43],

Packet footer[XX XX]

## 9.2 LCD Power-OFF Sequence

PH :Packet Header

PD :Packet Data

PF:Packet Footer (=Checksum)

No.		Function	DNC	Command /Parameter	Type	Command/Parameter
1	Display off	Display off	0	28h	PH	[05 28 00 06]
	Wait	wait 5 msec or more				
2	Sleep in	Sleep in	0	10h	PH	[05 10 00 2C]
	Wait	wait 2 frames or more				
3	Video signals	Video signals stop				

↓  
Power off

## 9.3 LCD Sleep Sequence

No.		Function	DNC	Command /Parameter	Type	Command/Parameter
1	Sleep in	Sleep in	0	10h	PH	[05 10 00 2C]
	Wait	wait 2 frames or more				
2	Video signals	Video signals stop				

## 9.4 LCD Sleep Release Sequence

No.		Function	DNC	Command /Parameter	Type	Command/Parameter
1	Video signals	Video signals start				
	Wait	wait 2 frames or more				
2	Sleep out	Sleep out	0	11h	PH	[05 11 00 36]

## 9.5 LCD Refresh Sequence

PH :Packet Header

PD :Packet Data

PF:Packet Footer (=Checksum)

No.		Function	DNC	Command /Parameter	Type	Command/Parameter
1	Sleep out	Sleep out	0	11h	PH	[05 11 00 36]
	Wait	wait 100 msec or more				
2	Enable extended commands	Enable extended commands	0	B9h	PH	[39 04 00 2C]
		Parameter 1	1	FFh	PD	[B9 FF 83 63]
		Parameter 2	1	83h	PF	[XX XX]
		Parameter 3	1	63h		
3	Set lane number/ operation mode	Two data lane, Sync Pulses mode *1	0	BAh	PH	[39, 0E, 00, 15]
		Parameter 1	1	80h	PD	[BA 80 00 10 08 08 10 7E 6E 6D 0A 01 80 43]
		Parameter 2	1	00h	PF	[XX XX]
		Parameter 3	1	10h		
		Parameter 4	1	08h		
		Parameter 5	1	08h		
		Parameter 6	1	10h		
		Parameter 7	1	7Eh		
		Parameter 8	1	6Eh		
		Parameter 9	1	6Dh		
		Parameter 10	1	0Ah		
		Parameter 11	1	01h		
		Parameter 12	1	80h		
		Parameter 13	1	43h		
4	Memory access control	Memory access control	0	36h	PH	[15 36 00 29]
		Parameter 1	1	00h		
5	Interface pixel format	Interface pixel format	0	3Ah	PH	[15 3A 70 28]
		Parameter 1( 24bit/pixel)	1	70h		
	Wait	wait 5 msec or more				
6	Set power	Set power	0	B1h	PH	[39 0D 00 13]
		Parameter 1	1	78h	PD	[B1 78 24 06 02 02 03 10 10 34 3C 3F 3F]
		Parameter 2	1	24h	PF	[XX XX]
		Parameter 3	1	06h		
		Parameter 4	1	02h		
		Parameter 5	1	02h		
		Parameter 6	1	03h		
		Parameter 7	1	10h		
		Parameter 8	1	10h		
		Parameter 9	1	34h		
		Parameter 10	1	3Ch		
		Parameter 11	1	3Fh		
		Parameter 12	1	3Fh		

PH :Packet Header

PD :Packet Data

PF:Packet Footer (=Checksum)

No.		Function	DNC	Command /Parameter	Type	Command/Parameter
7	Set display waveform cycle	Set display waveform cycle	0	B4h	PH	[39 0A 00 36]
		Parameter 1	1	00h	PD	[B4 00 08 6E 07 01 01 5E 01 57]
		Parameter 2	1	08h	PF	[XX XX]
		Parameter 3	1	6Eh		
		Parameter 4	1	07h		
		Parameter 5	1	01h		
		Parameter 6	1	01h		
		Parameter 7	1	5Eh		
		Parameter 8	1	01h		
		Parameter 9	1	57h		
8	Set panel	Set panel	0	CCh	PH	[15 CC 0B 22]
		Parameter 1	1	0Bh		
9	Set gamma curve related setting	Set gamma curve related setting	0	E0h	PH	[39 1F 00 29]
		Parameter 1	1	01h	PD	[E0 01 48 50 4E 58 F6 0B 4E 52 D5 15 95 55 CE 11 01 88 50 55 5F FD 0A 4E 91 D3 17 95 96 8E 11]
		Parameter 2	1	48h		
		Parameter 3	1	50h	PF	[XX XX]
		Parameter 4	1	4Eh		
		Parameter 5	1	58h		
		Parameter 6	1	F6h		
		Parameter 7	1	0Bh		
		Parameter 8	1	4Eh		
		Parameter 9	1	52h		
		Parameter 10	1	D5h		
		Parameter 11	1	15h		
		Parameter 12	1	95h		
		Parameter 13	1	55h		
		Parameter 14	1	CEh		
		Parameter 15	1	11h		
		Parameter 16	1	01h		
		Parameter 17	1	88h		
		Parameter 18	1	50h		
		Parameter 19	1	55h		
		Parameter 20	1	5Fh		
		Parameter 21	1	FDh		
		Parameter 22	1	0Ah		
		Parameter 23	1	4Eh		
		Parameter 24	1	91h		
		Parameter 25	1	D3h		
		Parameter 26	1	17h		
		Parameter 27	1	95h		
		Parameter 28	1	96h		
		Parameter 29	1	8Eh		
		Parameter 30	1	11h		
	Wait	wait 5 msec or more				
10	Display on	Display on	1	29h	PH	[05 29 00 1C]



### 9.6 Power ON/OFF timing

#### 9.6.1 LCD Power ON/OFF timing

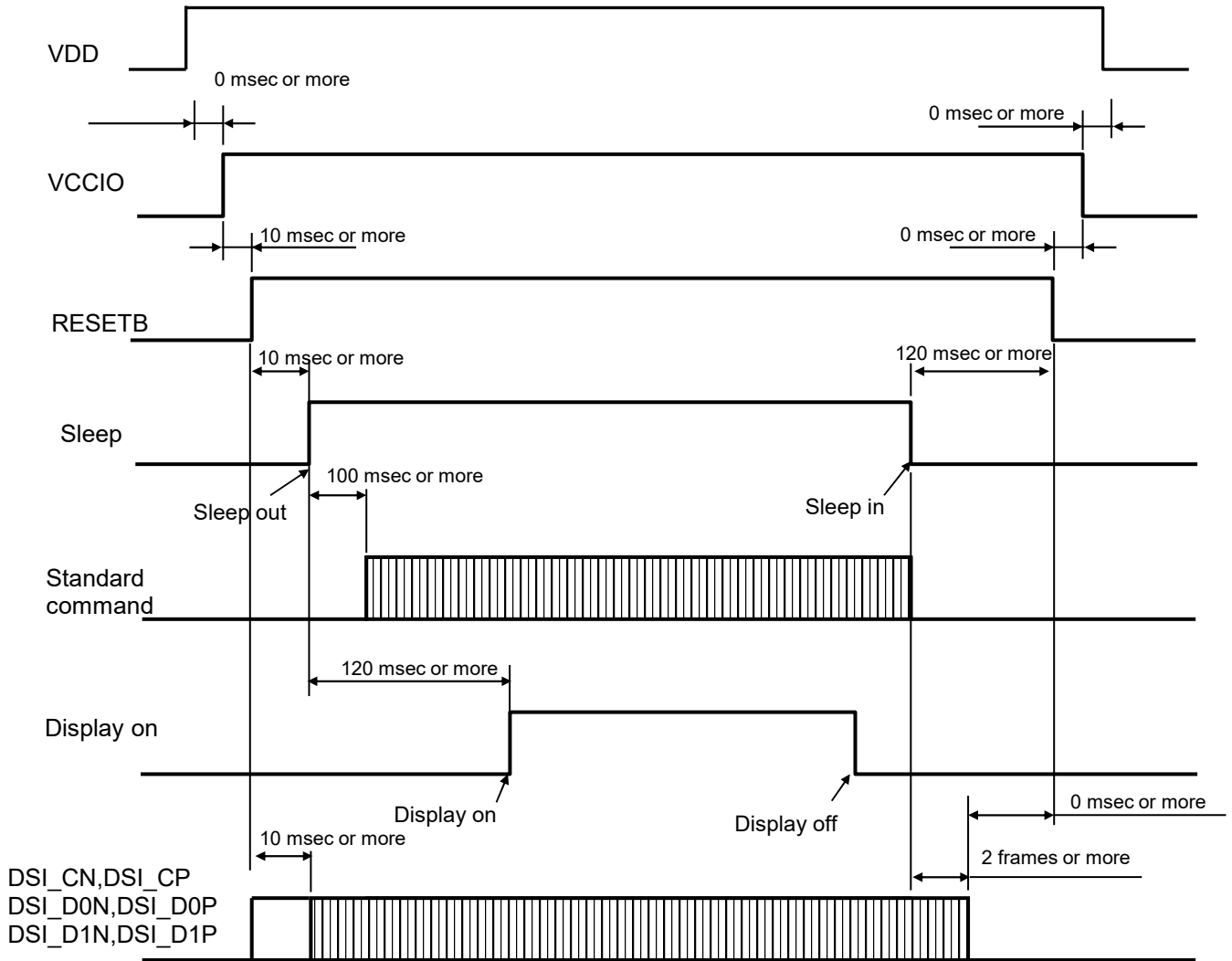

#### 9.6.2 TP Power ON timing

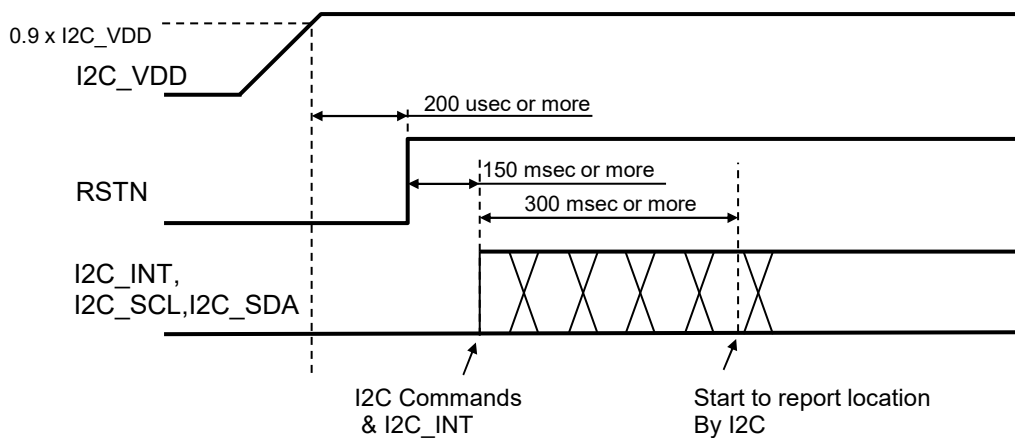

Note : There's reset while power-on and power-off to power-on

## 9.6.3 TP Power-off to Power-on timing

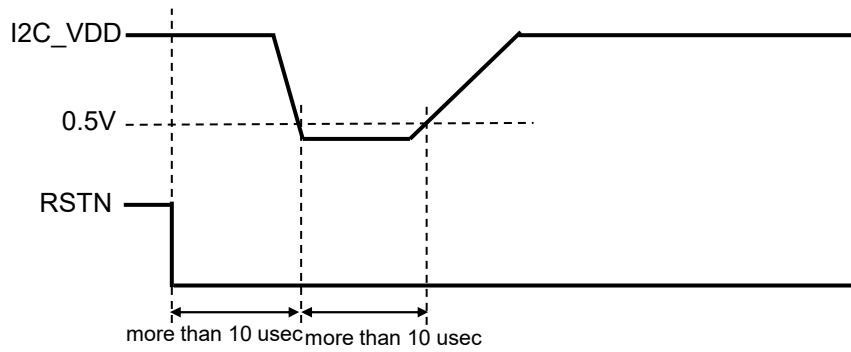

- Note.** 1. During the power off time, the I2C\_VDD must be lower than 0.5V that make sure the touch controller have been correctly reset.  
2. I2C\_VDD/I2C\_SCL/I2C\_SDA/I2C\_INT power-off sequence free.

## 10. TP Interface - I2C AC Characteristics

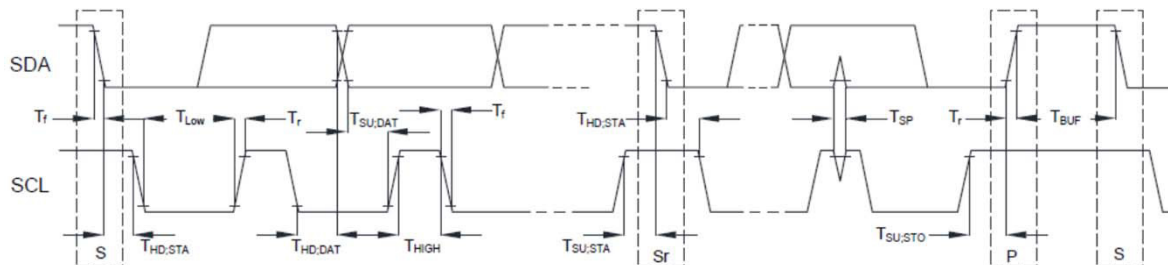

(Unless otherwise noted,  $T_a=25\text{ }^\circ\text{C}$ ,  $V_{DD}=I2C\_VDD=3.3\text{V}$ ,  $V_{CCIO}=1.8\text{V}$ ,  $GND=0\text{V}$ )

Symbol	Parameter	100kHz			400kHz		
		MIN	MAX	Unit	MIN	MAX	Unit
$F_{SCL}$	SCL clock frequency	0	100	kHz	0	400	kHz
$T_{HD:STA}$	Hold time (repeated) START condition. After this period, the first clock pulse is generated	4.0	-	us	0.6	-	us
$T_{LOW}$	LOW period of the SCL clock	4.7	-	us	1.3	-	us
$T_{HIGH}$	HIGH period of the SCL clock	4.0	-	us	0.6	-	us
$T_{SU:STA}$	Set-up time for a repeated START condition	4.7	-	us	0.6	-	us
$T_{HD:DAT}$	Data hold time	0	3.45	us	0	0.9	us
$T_{SU:DAT}$	Data set-up time	250	-	ns	100	-	ns
$T_r$	Rise time of both SDA and SCL signals	-	1000	ns	-	300	ns
$T_f$	Fall time of both SDA and SCL signals	-	300	ns	-	300	ns
$T_{SU:STO}$	Set-up time for STOP condition	4.0	-	us	0.6	-	us
$T_{BUF}$	Bus free time between a STOP and START condition	4.7	-	us	1.3	-	us
$T_{SP}$	Pulse width of spikes which must be suppressed by the input filter	-	-	ns	0	50	ns

11. LED Circuit

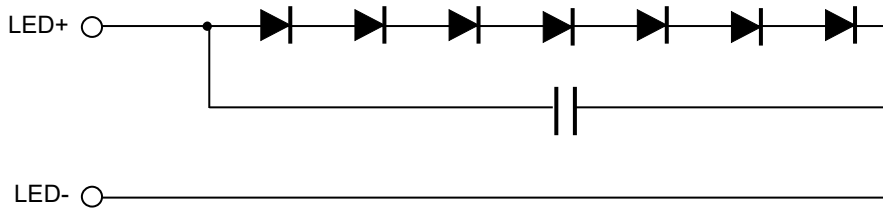

## 12. Characteristics

## 12.1 Optical Characteristics

(Measurement Condition)

Measuring instruments: CS2000 (KONICA MINOLTA), LCD7200 (OTSUKA ELECTRONICS), EZcontrastXL88 (ELDIM)

Driving condition: VDD=3.3V, VCCIO=1.8V, Optimized VCOMDC

Backlight: IL= 7.0 mA

Measured temperature: Ta = 25°C

Item		Symbol	Condition	MIN	TYP	MAX	Unit	Note №	Remark
Response time	Rise time	TON	[Data]= 00h → FFh	-	-	40	ms	1	
	Fall time	TON +	[Data]= FFh → 00h	-	-	60			
Contrast ratio	Backlight ON	CR	[Data]= FFh / 00h	-	600	-		2	
	Backlight OFF			-	1.6	-			
Viewing angle	Left	θL	[Data]= FFh / 00h CR ≥ 10	-	80	-	deg	3	
	Right	θR		-	80	-			
	Up	φU		-	80	-			
	Down	φD		-	80	-			
White Chromaticity		x y	[Data]= FFh	White chromaticity range				4	
Center Brightness			[Data]= FFh	200	280	-	cd/m <sup>2</sup>	5	
Brightness distribution			[Data]= FFh	70	-	-	%	6	
Burn-in				No noticeable burn-in image shall be observed after 2 hours of window pattern display.				7	

\* Note number 1 to 7: Refer to the APPENDIX of "Reference Method for Measuring Optical Characteristics".

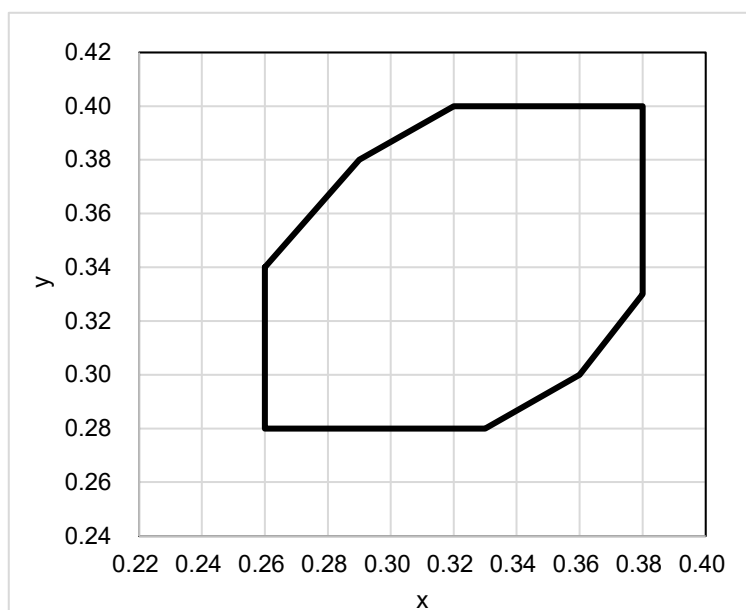

White Chromaticity Range

(White Chromaticity Range)

x	y
0.26	0.34
0.26	0.28
0.33	0.28
0.36	0.30
0.38	0.33
0.38	0.40
0.32	0.40
0.29	0.38

## 12.2 Temperature Characteristics

(Measurement Condition)

Measuring instruments: CS2000 (KONICA MINOLTA), LCD7200 (OTSUKA ELECTRONICS)

Driving condition: VDD=3.3V, VCCIO=1.8V, Optimized VCOMDC

Backlight: IL= 7.0 mA

Item		Symbol	Specification		Remark
			Ta = -10 °C	Ta = 70 °C	
Response time	Rise time	TON +	200 ms or less	30 ms or less	
	Fall time	TOFF	300 ms or less	50 ms or less	
Contrast ratio		CR	200 or more	200 or more	Backlight ON
Display Quality			No noticeable display defect or ununiformity should be observed.		

## 13. Criteria of Judgment

## 13.1 Defective Display and Screen Quality

Test Condition: Observed TFT-LCD monitor from front during operation with the following conditions

Driving Signal: Raster Patter (RGB, white, black)

Signal condition: [Data]:00h, 98h, FFh (3steps)

Observation distance: 30 cm

Illuminance: 200 to 350 lx

Backlight: IL=7.0mA

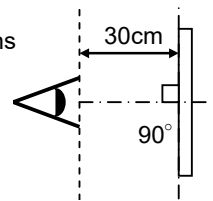

Defect item	Defect content	Criteria		
Display Quality	Line defect	Black, white or color line, 3 or more neighboring defective dots	Not exists	
	Dot defect	Uneven brightness on dot-by-dot base due to defective TFT or CF, or dust is counted as dot defect (brighter dot, darker dot)	Refer to table 1	
		High bright dot: Visible through 2% ND filter at [Data]=00h	Acceptable	
		Low bright dot: Visible through 5% ND filter at [Data]=00h Dark dot: Appear dark through white display at [Data]=98h Invisible through 5% ND filter at [Data]=00h		
Screen Quality	Stain	Uneven brightness (white stain, black stain etc)	Invisible through 5% ND filter at Black screen. Invisible through 1% ND filter at other screen.	
	Foreign particle	Point-like	$0.35\text{mm} < \varphi$	N=0
			$0.20\text{mm} < \varphi \leq 0.35\text{mm}$	$N \leq 5$
			$\varphi \leq 0.20\text{mm}$	Acceptable
		Liner	$0.10\text{mm} < \text{width or } 5.0\text{mm} < \text{length}$	N=0
	$0.05\text{mm} < \text{width} \leq 0.10\text{mm}, \text{ length} \leq 5.0\text{mm}$		$N \leq 5$	
$\text{width} \leq 0.05\text{mm}$	Acceptable			
Others		Use boundary sample for judgment when necessary		

$\varphi(\text{mm})$ : Average diameter = (major axis + minor axis)/2  
Permissible number: N

Table1

Area	High bright dot	Low bright dot	Dark dot	Total	Criteria
A	0	2	2	3	Permissible distance between same color bright dots (includes neighboring dots): 3 mm or more Permissible distance between same color high bright dots (includes neighboring dots): 5 mm or more
B	2	4	4	6	
Total	2	4	4	7	

<Portrait model>

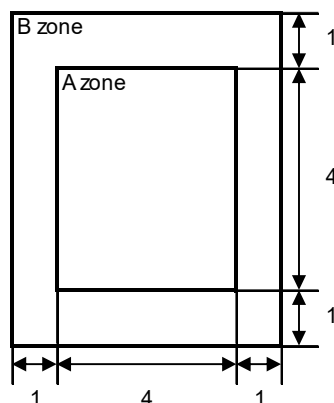

Division of A and B areas

B area: Active area

Dimensional ratio between A and B areas: 1: 4: 1

(Refer to the left figure)



## 13.2 Screen and Other Appearance

Testing conditions

Observation distance: 30 cm

Illuminance: 1200 ~ 2000 lx

Item	Criteria	Remark
Polarizer Flaw Stain Dirt Bubble Dust Dent	Ignore invisible defect when the backlight is on.	Applicable area: Active area only (Refer to the section 3.2 Outward Form)
S case	No functional defect occurs	
FPC	No functional defect occurs	

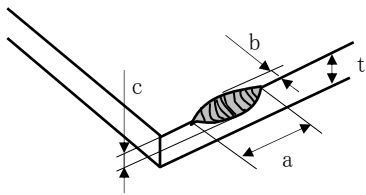
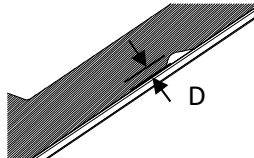
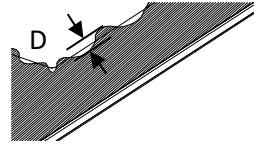
Item	Criteria		
Touch panel	Foreign particle Point-like	$0.35\text{mm} < \varphi$	N=0
		$0.20\text{mm} < \varphi \leq 0.35\text{mm}$	$N \leq 5$
		$\varphi \leq 0.20\text{mm}$	Ignored
		*Distance between two Dot-like Foreign Objects: Shall be located $\geq 10\text{mm}$ away *Foreign matter that can be wiped off is good	
	Liner	$0.10\text{mm} < \text{width or } 5.0\text{mm} < \text{length}$	N=0
		$0.05\text{mm} < \text{width} \leq 0.10\text{mm}$ length $\leq 5.0\text{mm}$	$N \leq 5$
		width $\leq 0.05\text{mm}$	Ignored
		*With the interval over than 10mm	
	Pin hole White dot Pit	$0.50\text{mm} < \varphi$	N=0
		$0.20\text{mm} < \varphi \leq 0.50\text{mm}$	$N \leq 3$
$\varphi \leq 0.20\text{mm}$		Ignored	
*With the interval over than 10mm			
Stain	No visible stain. Excluding stain which can be blown off or wiped off. For unremovable stain, a boundary sample shall be prepared by mutual consultation.		
Glass Chip	 <p>Not visible from the front side: Acceptable Visible from the front side: Acceptable <math>a \leq 2.0\text{mm}</math>, <math>b \leq 0.5\text{mm}</math>, <math>c \leq t</math> (Glass thickness) Neither exceed the permissible range Convex shape must be within tolerance</p>		
Chipping of the printing part		$0.20\text{mm} < D$	N=0
		$D \leq 0.20\text{mm}$	Ignored
Printing window frame Saw tooth shape unevenness		$0.20\text{mm} < D$	N=0
		$D \leq 0.20\text{mm}$	Ignored
Newton ring	Not Applicable		

D(mm): Average diameter = (major axis + minor axis)/2

Permissible number: N

\*In the item setting a boundary sample, the specification of the boundary sample shall supersede other specifications.



## 14. Reliability Test

Test item		Test condition		number of failures / number of examinations
Durability test	High temperature storage	Ta = 80°C	240hrs	0/3
	Low temperature storage	Ta = -30°C	240hrs	0/3
	High temperature & high humidity storage	Ta = 60°C, RH = 90%, non condensing	240hrs	0/3
	High temperature operation	Tp = 70°C	240hrs	0/3
	Low temperature operation	Tp = -20°C	240hrs	0/3
	High temperature & high humidity operation	Tp = 40°C, RH = 90%, non condensing	240hrs	0/3
	Thermal shock storage	-30°C ↔ 80°C (30min / 30min)	100cycles	0/3
Mechanical environmental test	Electrostatic discharge test (Non operation)	Confirms to EIAJ ED-4701/300, C=200pF,R=0Ω,V=±200V Each 3 times of discharge on and power supply and other terminals.		0/3
	Surface discharge test (Non operation)	C=250pF, R=100Ω, V=±12kV Each 5 times of discharge in both polarities on the center of screen with the case grounded.		0/3
	Vibration test	Total amplitude 1.5mm, f=10~55Hz, X,Y,Z directions for each 2 hours		0/3
	Impact test	Use TOPPAN original jig (see next page) and make an impact with peak acceleration of 1000m/s <sup>2</sup> for 6 msec with half sine-curve at 3 times to each X, Y, Z directions in conformance with JIS C 60068-2-27-2011.		0/3

Note: Ta=ambient temperature    Tp=Panel temperature

※ The profile of high temperature/humidity storage and High Temperature/humidity operation  
(Pure water of over 10MΩ·cm shall be used.)

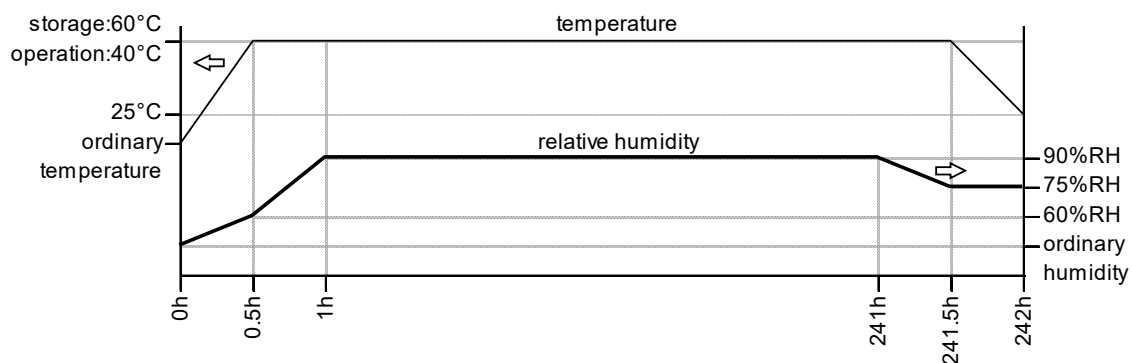

Table2. Reliability Criteria

The parameters should be measured after leaving the monitor at the ordinary temperature for 24 hours  
or more after the test completion.

Item	Standard	Remark
Display quality	No visible abnormality shall be seen. (Except for unevenness by PoI deterioration.)	
Contrast ratio	200 or more	Backlight ON



TOPPAN Original Jig

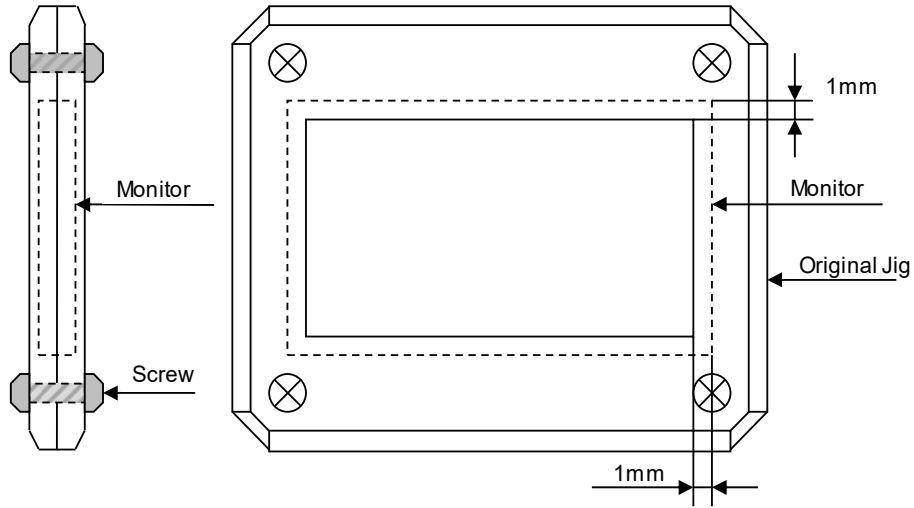



### 15. Packing Specifications

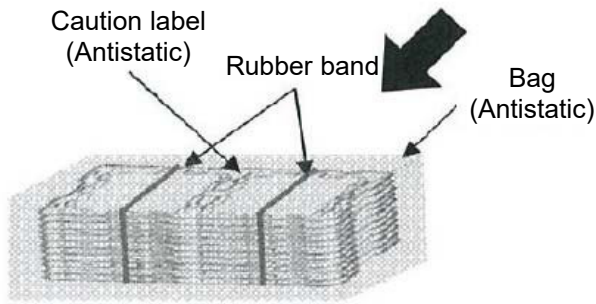
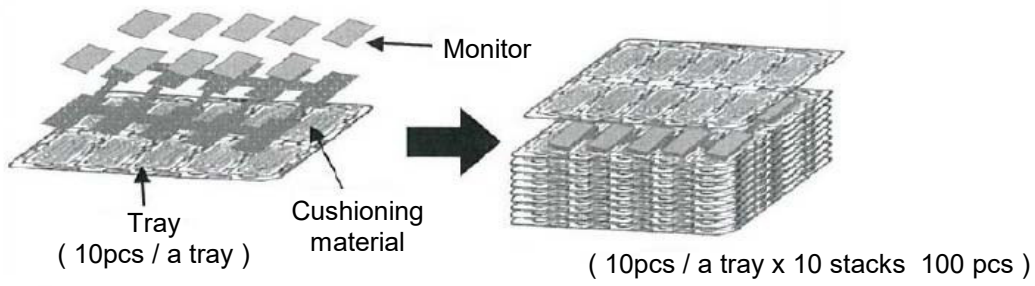

( 100 pcs / a bag x 2 = 200 pcs )

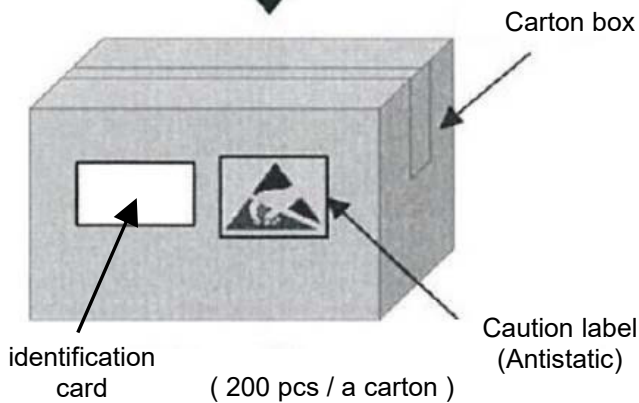
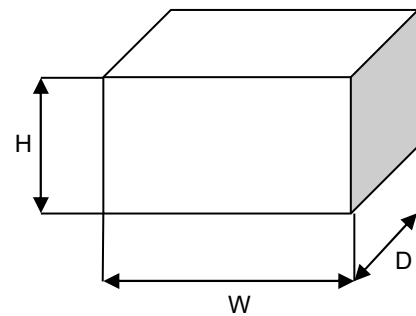
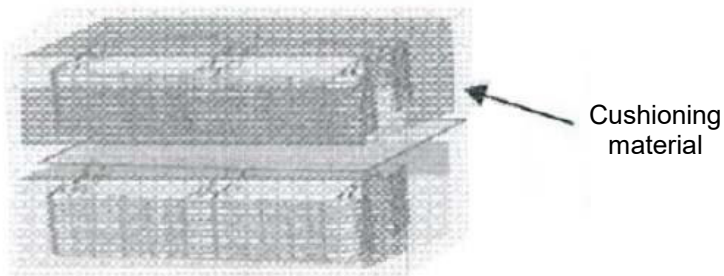

Dimension of Carton box	
D : Approx	( 340 mm )
W : Approx	( 485 mm )
H : Approx	( 270 mm )
Quantity of products packed in one carton	200 pcs
Gross weight: Approx	14.5 kg

## 16. Handling Instruction

### 16.1 Cautions for Handling LCD panels



#### Caution

- (1) Do not make an impact on the LCD panel glass because it may break and you may get injured from it.
- (2) If the glass breaks, do not touch it with bare hands.  
(Fragment of broken glass may stick you or you cut yourself on it.)
- (3) If you get injured, receive adequate first aid and consult a medial doctor.
- (4) Do not let liquid crystal get into your mouth.  
(If the LCD panel glass breaks, try not let liquid crystal get into your mouth even toxic property of liquid crystal has not been confirmed.)
- (5) If liquid crystal adheres, rinse it out thoroughly.  
(If liquid crystal adheres to your cloth or skin, wipe it off with rubbing alcohol or wash it thoroughly with soap. If liquid crystal gets into eyes, rinse it with clean water for at least 15 minutes and consult an eye doctor.)
- (6) If you scrap this products, follow a disposal standard of industrial waste that is legally valid in the community, country or territory where you reside.
- (7) Do not connect or disconnect this product while its application products is powered on.
- (8) Do not attempt to disassemble or modify this product as it is precision component.
- (9) If a part of soldering part has been exposed, and avoid contact (short-circuit) with a metallic part of the case etc. about FPC of this model, please.  
Please insulate it with the insulating tape etc. if necessary.  
The defective operation is caused, and there is a possibility to generation of heat and the ignition.
- (10) Since excess current protection circuit is not built in this TFT module, there is the possibility that LCD module or peripheral circuit become feverish and burned in case abnormal operation is generated.  
We recommend you to add excess current protection circuit to power supply.
- (11) The end part of glass and film of touch panel has conductivity, and avoid contact (short-circuit) with electroconductive case etc.. There is a possibility of setting up a defective touch panel, and insulate it for the case suppression (cushion etc.) if necessary, please.
- (12) The devices on the FPC are damageable to electrostatic discharge, because the terminals of the devices are exposed.  
Wear grounded wrist-straps and use electrostatic neutralization blowers to prevent static charge and discharge when handling the TFT monitors.  
Designate an appropriate operating area, and set equipment, tools, and machines properly when handling this product.



#### Caution

This mark is used to indicate a precaution or an instruction which, if not correctly observed, may result in bodily injury, or material damages alone.

## 16.2 Precautions for Handling

- 1) Wear finger tips at incoming inspection and for handling the TFT monitors to keep display quality and keep the working area clean.  
Do not touch the surface of the monitor as it is easily scratched.
- 2) Wear grounded wrist-straps and use electrostatic neutralization blowers to prevent static charge and discharge when handling the TFT monitors as the LED in this TFT monitors is damageable to electrostatic discharge.  
Designate an appropriate operating area, and set equipment, tools, and machines properly when handling this product.
- 3) Avoid strong mechanical shock including knocking, hitting or dropping to the TFT monitors for protecting their glass parts.  
Do not use the TFT monitors that have been experienced dropping or strong mechanical shock.
- 4) Do not use or storage the TFT monitors at high temperature and high humidity environment.  
Particularly, never use or storage the TFT monitors at a location where condensation builds up.
- 5) Avoid using and storing TFT monitors at a location where they are exposed to direct sunlight or ultraviolet rays to prevent the LCD panels from deterioration by ultraviolet rays.
- 6) Do not stain or damage the contacts of the FPC cable .  
FPC cable needs to be inserted until it can reach to the end of connector slot.  
During insertion, make sure to keep the cable in a horizontal position to avoid an oblique insertion.  
Otherwise, it may cause poor contact or deteriorate reliability of the FPC cable.
- 7) The FPC cable is a design very weak to the bend and the pull as it is fixed with the tape.  
Do not bend or pull the FPC cable or carry the TFT monitor by holding the FPC cable.
- 8) Peel off the protective film on the TFT monitors during mounting process.  
Refer to the section 16.5 on how to peel off the protective film.  
We are not responsible for electrostatic discharge failures or other defects occur when peeling off the protective film.

## 16.3 Precautions for Operation

- 1) Since this TFT monitors are not equipped with light shielding for the driver IC,  
do not expose the driver IC to strong lights during operation as it may cause functional failures.
- 2) In case of powering up or powering off this LCD module,  
be sure to comply the sequence as instructed in this specification.
- 3) Do not plug in or out the FPC cable while power supply is switch on.  
Plug the FPC cable in and out while power supply is switched off.
- 4) Do not operate the TFT monitors in the strong magnetic field. It may break the TFT monitors.
- 5) Do not display a fixed image on the screen for a long time.  
Use a screen-saver or other measures to avoid a fixed image displayed on the screen for a long time.  
Otherwise, it may cause burn-in image on the screen due the characteristics of liquid crystal.



#### 16.4 Storage Condition for Shipping Cartons

(Storage environment)

- Temperature 0 to 40° C
- Humidity 60%RH or less  
No-condensing occurs under low temperature with high humidity condition.
- Atmosphere No poisonous gas that can erode electronic components and/or wiring materials should be detected.
- Time period 1 year
- Unpacking To prevent damages caused by static electricity, anti-static precautionary measures (e.g. earthing, anti-static mat) should be implemented.  
After unpack, keep product in the appropriate condition, otherwise bubble seal of Protective film may be printed on Polarizer.
- Maximum piling up 4 cartons

\*Conditions to storage after unpacking

(Storage environment)

- Temperature 0 to 40° C
- Humidity 60%RH or less  
No-condensing occurs under low temperature with high humidity condition.
- Atmosphere No poisonous gas that can erode electronic components and/or wiring materials should be detected.
- Time period 1 year (Shelf life)
- Others Keep/ store away from direct sunlight  
Storage goods on original tray made by TOPPAN.

### 16.5 Precautions for Peeling off the Protective film

The followings work environment and work method are recommended to prevent the TFT monitors from static damage or adhesion of dust when peeling off the protective films.

#### A) Work Environment

- a) Humidity: 50 to 70 %RH, Temperature 15 to 27° C
- b) Operators should wear conductive shoes, conductive clothes, conductive finger tips and grounded wrist-straps.  
Use an electrostatic neutralization blower.
- c) Anti-static treatment should be implemented to work area's floor.  
Use a room shielded against outside dust with sticky floor mat laid at the entrance to eliminate dirt.

#### B) Work Method

The following procedures should taken to prevent the driver ICs from charging and discharging.

- a) Use an electrostatic neutralization blower to blow air on the TFT monitors to its lower right when FPC is placed at lower right.  
Optimize direction of the blowing air and the distance between the TFT monitors and the electrostatic neutralization blower.
- b) Peel off the Tab slowly (spending more than 2 secs to complete)  
by pulling it to opposite direction.

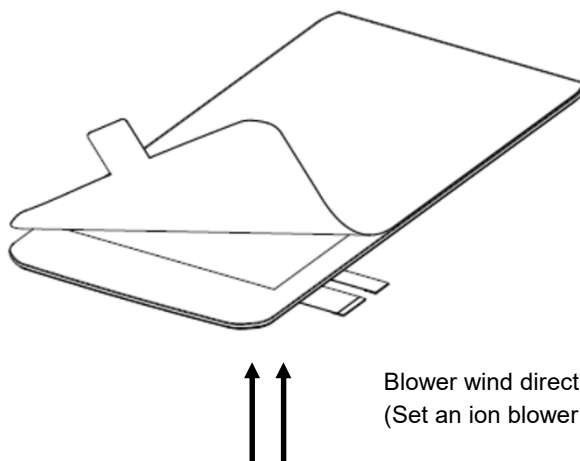

### 16.6 Warranty

TOPPAN is only liable to defective goods which is stored and used under the condition complying with this specifications and returned within 1 (one) year.

Warranty caused by manufacturing defect shall be conducted by replacement of goods or refundment at unit price.

**APPENDIX**

Reference Method for Measuring Optical Characteristics and Performance

1. Measurement Condition (Backlight ON)

Measuring instruments: CS2000 (KONICA MINOLTA), LCD7200 (OTSUKA ELECTRONICS), EZcontrastXL88 (ELDIM)

Driving condition: Refer to the section "Optical Characteristics"

Measured temperature: 25°C unless specified

Measurement system: See the chart below. The luminance meter is placed on the normal line of measurement system.

Measurement point: At the center of the screen unless otherwise specified

Dark box at constant temperature

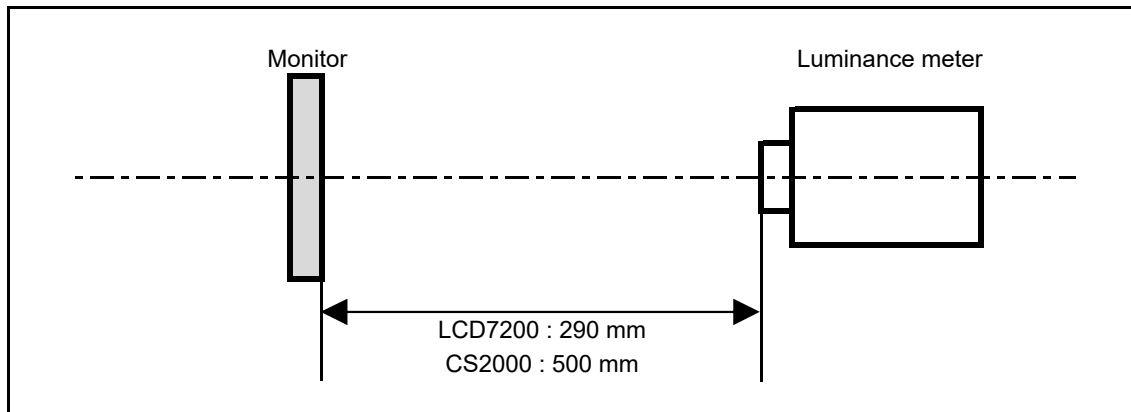

\*Measurement is made after 30 minutes of lighting of the backlight.

Measurement point: At the center point of the screen

Brightness distribution: 9 points shown in the following drawing.

<Portrait model>

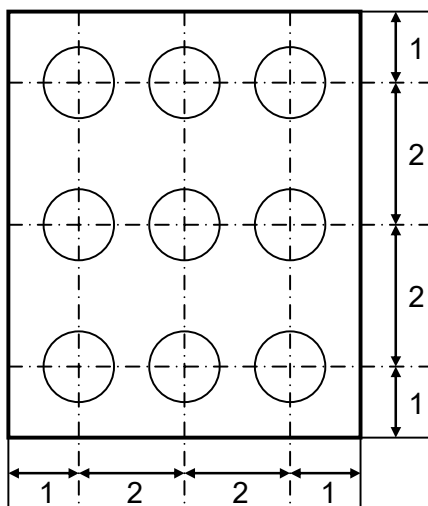

Dimensional ratio of active area

Backlight IL=7.0mA

Measurement Condition (Contrast ratio Backlight OFF only)

Measuring instruments: LCD7200(OTSUKA ELECTRONICS) , Ring Light (40,000 lx,  $\phi 58$ )

Driving condition: Refer to the section "Optical Characteristics"

Measured temperature: 25°C unless specified

Measurement system: See the chart below.

Measurement point: At the center of the screen unless otherwise specified

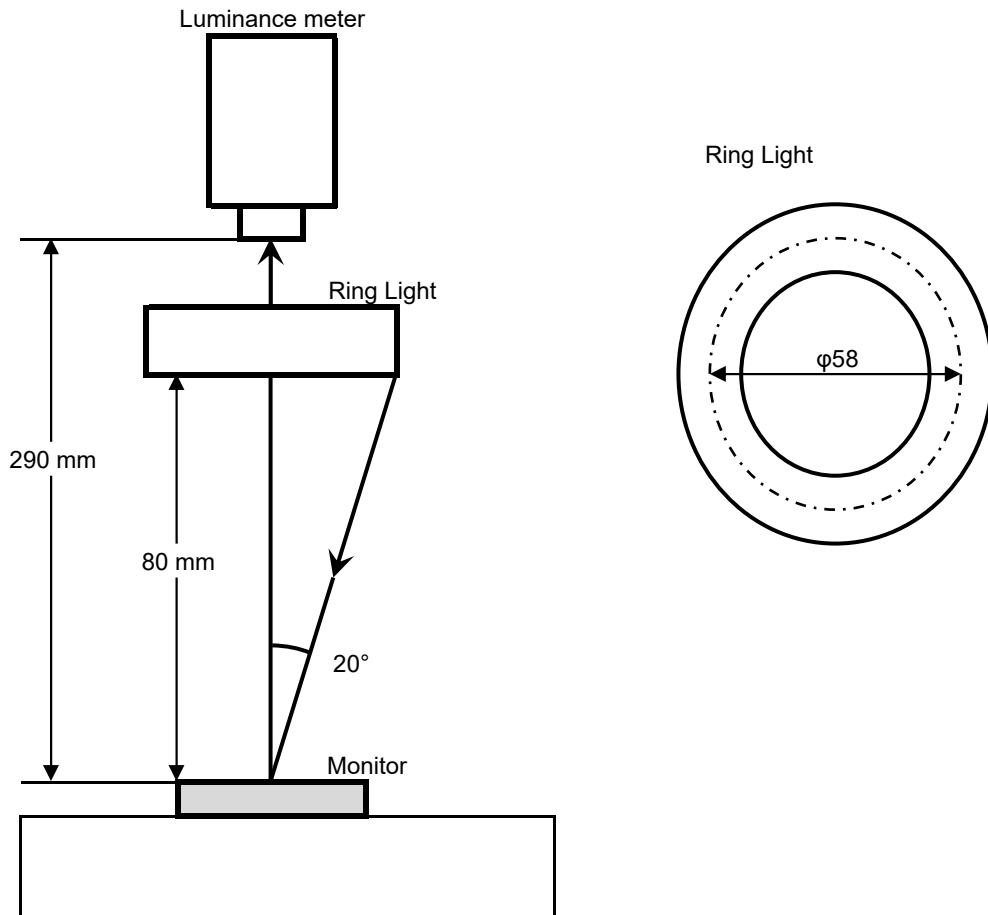

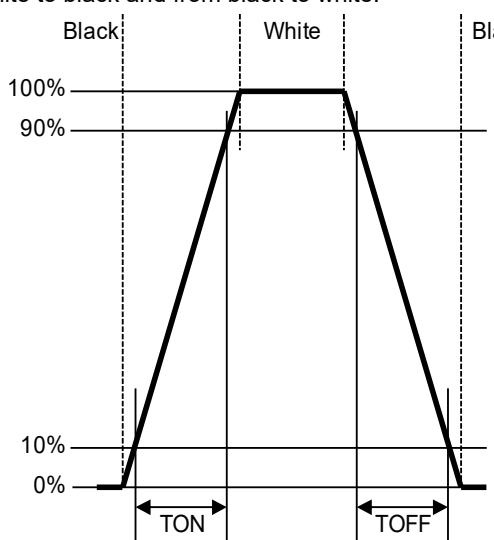

## 2. Test Method

Notice	Item	Test method	Measuring instrument	Remark
1	Response time	Measure output signal waveform by the luminance meter when raster of window pattern is changed from white to black and from black to white. 	LCD7200	Black display [Data]=00h White display [Data]=FFh TON Rise time TOFF Fall time
2	Contrast ratio	Measure maximum luminance Y1([Data]=FFh) and minimum luminance Y2([Data]=00h) at the center of the screen by displaying raster or window pattern. Then calculate the ratio between these two values. $\text{Contrast ratio} = Y1/Y2$ Diameter of measuring point: 7.8mmφ(CS2000) Diameter of measuring point: 3mmφ(LCD7200)	CS2000 LCD7200	Backlight ON Backlight OFF
3	Viewing angle Horizontalθ Verticalφ	Move the luminance meter from right to left and up and down and determine the angles where contrast ratio is 10.	EZcontrastXL88	
4	White chromaticity	Measure chromaticity coordinates x and y of CIE1931 colorimetric system at [Data] = FFh Color matching function: 2°view measurement angle: 1°	CS2000	
5	Center brightness	Measure the brightness at the center of the screen.	CS2000	
6	Brightness distribution	$(\text{Brightness distribution}) = 100 \times B/A \%$ A : max. brightness of the 9 points B : min. brightness of the 9 points	CS2000	
7	Burn-in	Visually check burn-in image on the screen after 2 hours of "window display" ([Data]=00h/FFh).		At optimized VCOMDC

# DATA MODUL



ALL TECHNOLOGIES. ALL COMPETENCIES. ONE SPECIALIST.



**DATA MODUL AG**  
Landsberger Straße 322  
DE-80687 Munich  
Phone: +49 89 56017 0

**DATA MODUL WEIKERSHEIM GMBH**  
Lindenstraße 8  
DE-97990 Weikersheim  
Phone: +49 7934 101 0

