



SPECIFICATION

ORTUSTECH

COM57H5N32XSC

5.7" – 640 x 480 – RGB – Blanview

Version: 1.0

Date: 22.09.2023

Note: This specification is subject to change without prior notice

Specifications for
Blanview TFT-LCD Monitor
(5.7" VGA 640 x RGB x 480 Landscape)

Version 1.0

(Please be sure to check the specifications latest version.)

MODEL COM57H5N32XSC

Customer's Approval

Signature :

Name :

Section :

Title :

Date :

ORTUSTECH



TOPPAN INC.
Electronics Division
Technological Development Department III

Approved by

S. Euchi

Checked by

J. Matsuzaki

Prepared by

M. Jojo

Version History

Ver.	Date	Page	Description
0.0	Oct.26,2022	-	- Tentative issue
1.0	Sep.22,2023	-	- First issue
△ ×10		P.1	Cover
		Change	Department name
		P.5	2.2 Display Method
		Add	NTSC ratio
		Correct	Error correct
		P.7	3.1 Dimensions
		Correct	Weight
		P.13	8.1.1 Display Module
		Correct	Rating
			8.1.2 Backlight
		Add	Condition / Rating
		P.19	10.1 Optical Characteristics
		Add	BL current / Rating / White Chromaticity Range
		P.20	10.2 Temperature Characteristics
Add	BL current / Specification		
P.21	11.1 Defective Display and Screen Quality		
Add	Signal condition / BL current		
Correct	Notation		
P.23	12. Reliability Test		
Add	number of failures /number of examinations		
Add	Applied voltage (Surface discharge test)		
P.30	APPENDIX		
Add	BL current		

Contents

1. Application	4
2. Outline Specifications		
2.1 Features of the Product	5
2.2 Display Method	5
3. Dimensions and Shape		
3.1 Dimensions	7
3.2 Outward Form	8
3.3 Serial Label (S-Label)	9
4. Pin Assignment	
4.1 Display Module Part	10
4.2 Backlight Part	10
5. Block Diagram	11
6. Absolute Maximum Rating	12
7. Recommended Operating Conditions	12
8. Electrical Characteristics		
8.1 DC Characteristics	13
8.2 AC Characteristics	13
8.3 Input Timing Characteristics	15
8.4 Driving Timing Chart	16
8.5 Example of Driving Timing Chart (fCLK=25MHz)	17
9. "DISP" on/off Sequence	18
10. Characteristics		
10.1 Optical Characteristics	19
10.2 Temperature Characteristics	20
11. Criteria of Judgment		
11.1 Defective Display and Screen Quality	21
11.2 Screen and Other Appearance	22
12. Reliability Test	23
13. Packing Specifications	25
14. Handling Instruction		
14.1 Cautions for Handling LCD panels	26
14.2 Precautions for Handling	27
14.3 Precautions for Operation	27
14.4 Storage Condition for Shipping Cartons	28
14.5 Precautions for Peeling off the Protective film	29
14.6 Warranty	29
APPENDIX	30

1. Application

This Specification is applicable to 144.0 mm (5.7 inch) Blanview TFT-LCD monitor for non-military use.

- ◎ TOPPAN makes no warranty or assume no liability that use of this Product and/or any information including drawings in this Specification by Purchaser is not infringing any patent or other intellectual property rights owned by third parties, and TOPPAN shall not grant to Purchaser any right to use any patent or other intellectual property rights owned by third parties. Since this Specification contains TOPPAN's confidential information and copy right, Purchaser shall use them with high degree of care to prevent any unauthorized use, disclosure, duplication, publication or dissemination of TOPPAN's confidential information and copy right.
- ◎ If Purchaser intends to use this Products for an application which requires higher level of reliability and/or safety in functionality and/or accuracy such as transport equipment (aircraft, train, automobile, etc.), disaster-prevention/security equipment or various safety equipment, Purchaser shall consult TOPPAN on such use in advance.
- ◎ This Product shall not be used for application which requires extremely higher level of reliability and/or safety such as aerospace equipment, telecommunication equipment for trunk lines, control equipment for nuclear facilities or life-support medical equipment.
- ◎ It must be noted as an mechanical design manner, especial attention in housing design to prevent arcuation/flexure caused by stress to the LCD module shall be considered.
- ◎ TOPPAN assumes no liability for any damage resulting from misuse, abuse, and/or miss-operation of the Product deviating from the operating conditions and precautions described in the Specification.
- ◎ It shall be mutually conferred if nonconforming defect which result from unspecified cause in this specification arises.
- ◎ If any issue arises as to information provided in this Specification or any other information, TOPPAN and Purchaser shall discuss them in good faith and seek solution.
- ◎ TOPPAN assumes no liability for defects such as electrostatic discharge failure occurred during peeling off the protective film or Purchaser's assembly process.
- ◎ This Product is compatible for RoHS(2.0) directive.

Object substance	Maximum content [ppm]
Cadmium and its compound	100
Hexavalent Chromium Compound	1000
Lead & Lead compound	1000
Mercury & Mercury compound	1000
Polybrominated biphenyl series (PBB series)	1000
Polybrominated biphenyl ether series (PBDE series)	1000
Bis(2-ethylhexyl)phthalate series(DEHP series)	1000
Butyl benzyl phthalate series(BBP series)	1000
Dibutyl phthalate series(DBP series)	1000
Diisobutyl phthalate series(DIBP series)	1000

2. Outline Specifications

2.1 Features of the Product

- 5.7 inch diagonal display, 1,920 [H] x 480 [V] dots.
- 6-bit 262,144 color display capability.
- 3.3V[TFT-LCD module] is required.
- Built in Timing generator (TG).
- Long life & high brightness LED back-light .
- All-in-one type monitor with lead-free mounting(Response to RoHS Phase 3A).
- Blanview TFT-LCD, improved outdoor readability.

	Indoor		Outdoor	
	Readability	Power Efficiency (Battery Life)	Readability	Power Efficiency (Battery Life)
Transmissive	Good	Good	Fair	Poor
Transflective	Fair	Poor	Good	Good
Blanview	Good	Good	Good	Good

2.2 Display Method

Items	Specifications	Remarks
Display type	TN type 262,144 colors. Blanview, Normally white	
Driving method	a-Si TFT Active matrix Line-scanning, Non-interlace	
Dot arrangement	RGB stripe arrangement	Refer to "Dot arrangement"
Signal input method	6-bit RGB, parallel input.	
Backlight type	Long life & High bright white LED.	
NTSC ratio	50%	

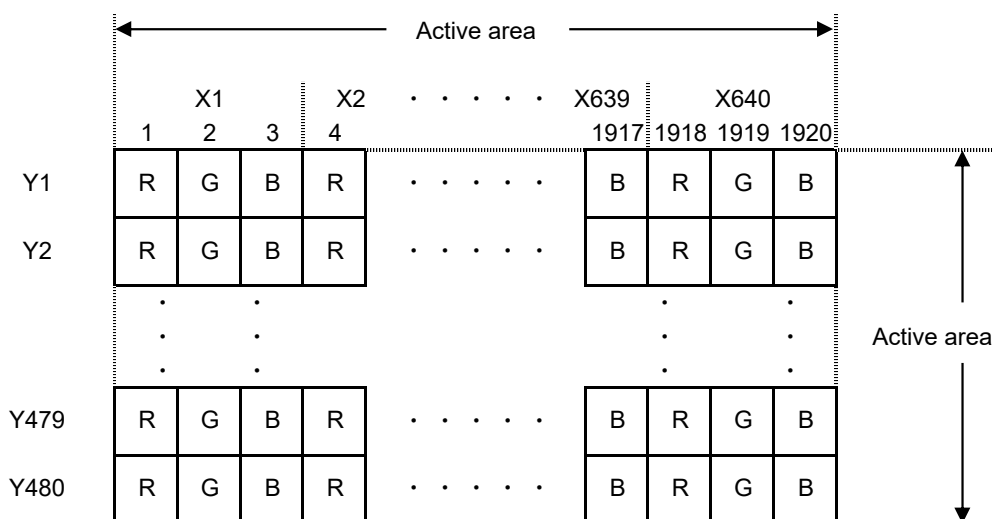

Dot arrangement
(When FPC is placed at the bottom)

<Features of Blanview>

- Backlight power consumption required to assure visibility. (equivalent to 3.5"QVGA)

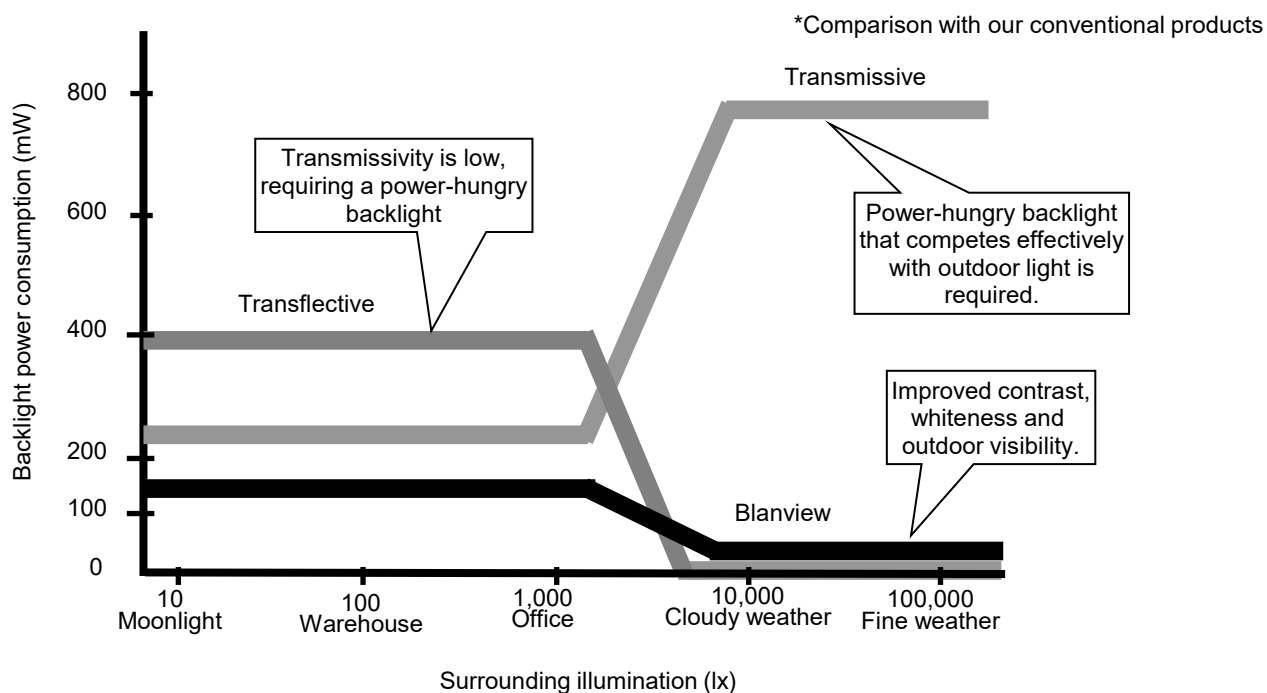

- Contrast characteristics under 100,000lx. (same condition as direct sunlight.)

With better contrast (higher contrast ratio), Blanview TFT-LCD has the best outdoor readability in three different types of TFT-LCD.

Below chart shows contrast value against panel surface brightness. (Horizontal: Panel surface brightness/ Vertical: Contrast value) LCD panel has enough outdoor readability above our Standard line. (TOPPAN criteria)

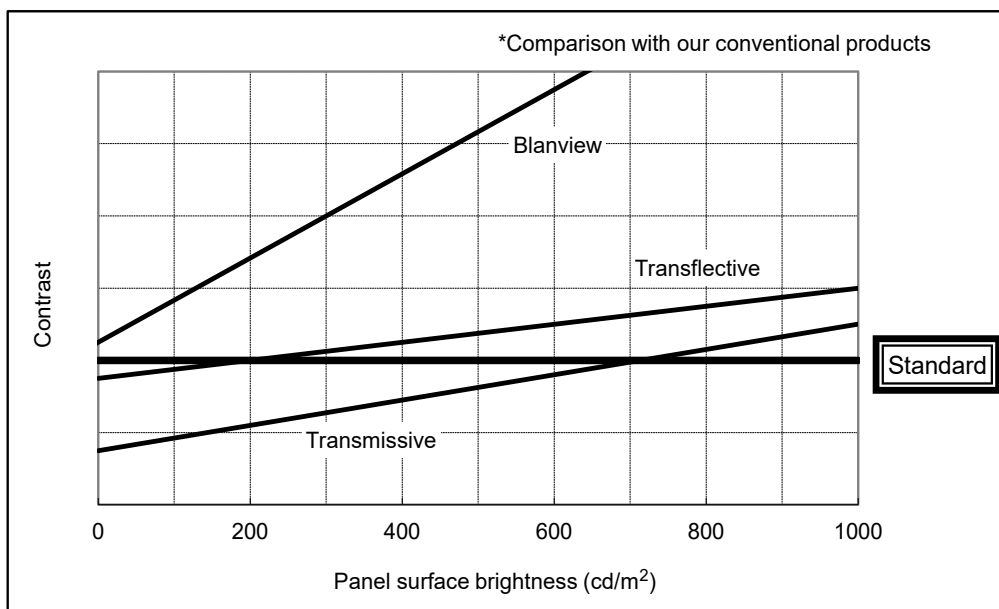

3. Dimensions and Shape

△ 3.1 Dimensions

Items	Specifications	Unit	Remarks
Outline dimensions	130.32[H] × 101.20[V] × 9.39[D]	mm	
Active area	115.20[H] × 86.40[V]	mm	144.0 mm diagonal
Number of dots	1,920[H] × 480[V]	dot	
Dot pitch	60.00[H] × 180.00[V]	μm	
Surface hardness of the polarizer	3	H	Load:2.0N
Weight	120	g	

EC No.	REV. No.	REVISE	DATE (Y:M:D)	APPROVED	CHECKED	PREPARED
###			##:##:##	##	##	

3.2 Outward Form

(8/32)
22TLM099
Issue: Sep.22,2023

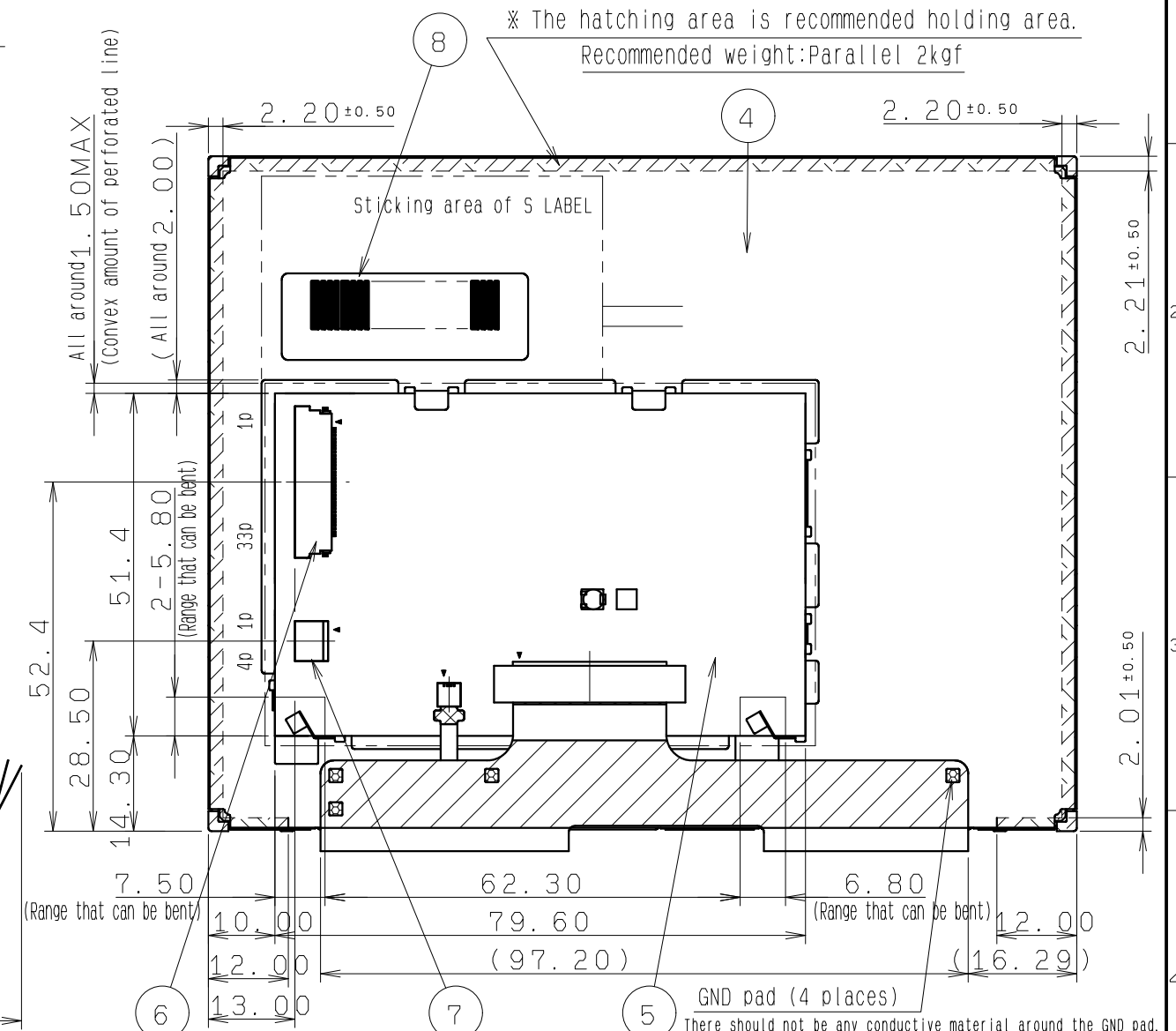
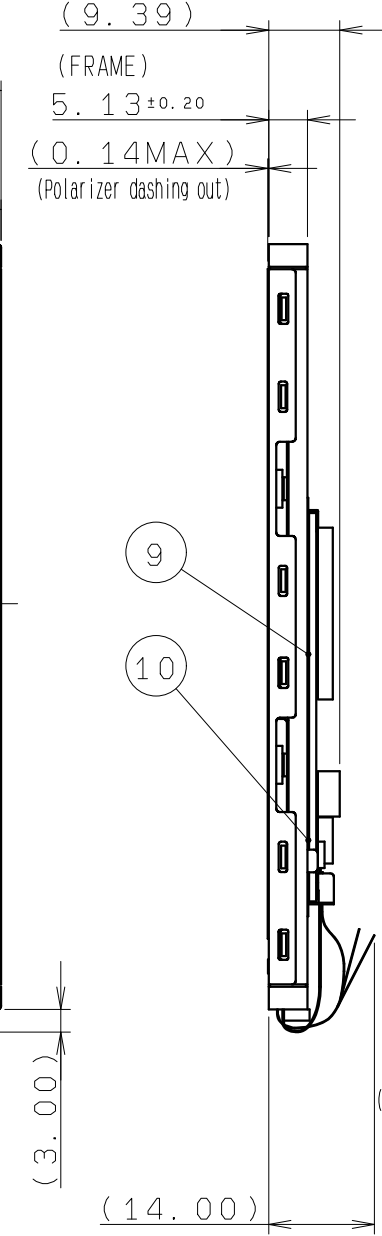
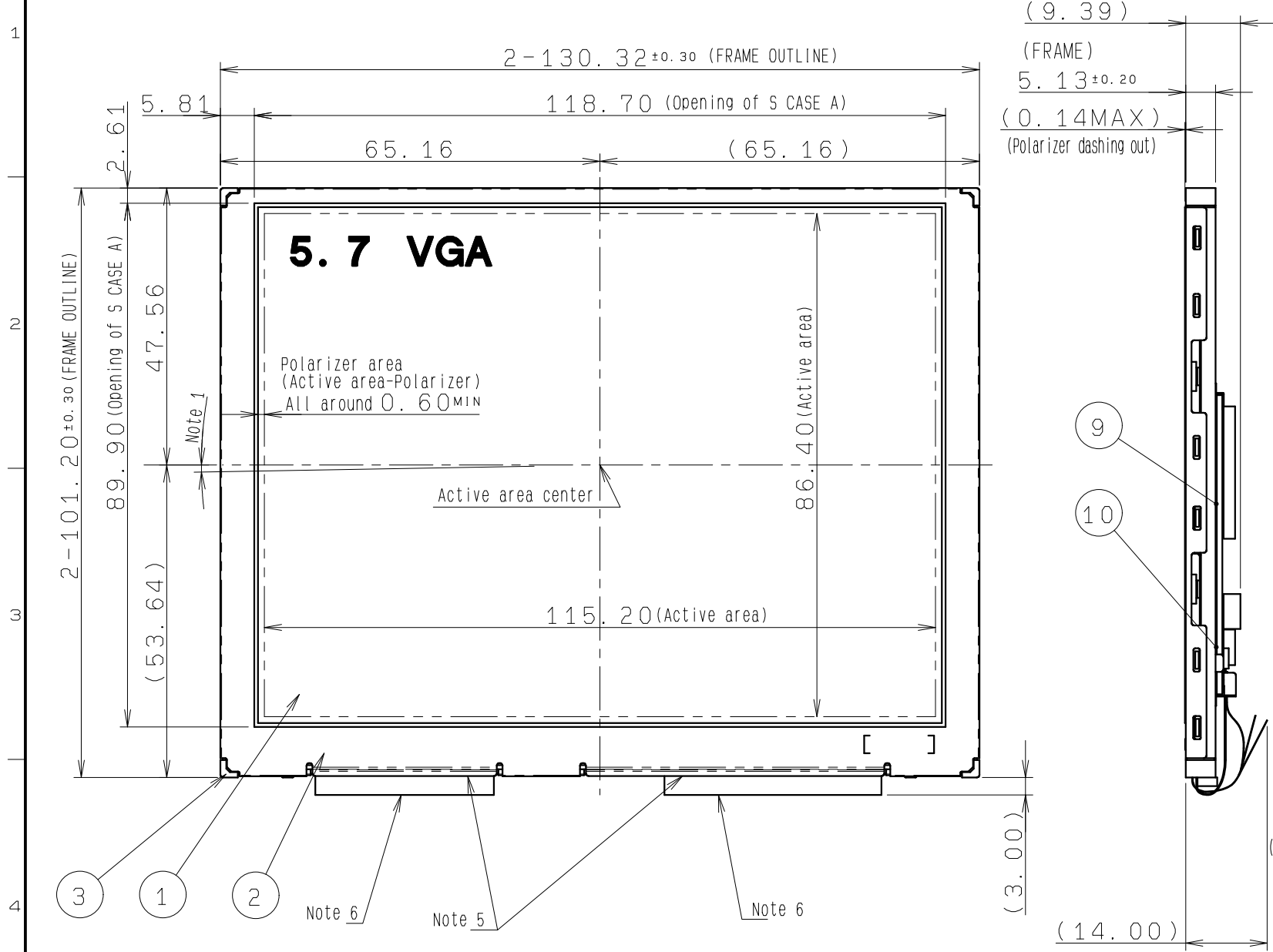

- Note 1. Angular deviation of LCD cell from the TFT-LCD monitor's reference axis shall be less than [±50'].
- Note 2. S label is affixed the area shown in the drawing. The thickness of the S label will be added to that of S case's surface.
- Note 3. Protective film is affixed on front surface of the screen. Location tolerance of the protective film shall be ±1.5 mm to the polarizing film.
- Note 4. Exercise care not to apply any forces to the PCB.
- Note 5. Exercise care not to apply any forces to the cable holder of the S case A.
- Note 6. Exercise care not to apply any forces to the cable.

W TAPE	10	(76.60x14.00x0.100t)	
I TAPE	9	(83.60x55.35x0.115t)	
S LABEL	8	Barcode(CODE39) (37x13x0.075t)	
CONNECTOR	7	SM04B-SRSS-G-TB(JST) pitch1.0x4pin	
CONNECTOR	6	04 6240 033 023 846+ (KYOCERA) pitch0.5x33pin	
PCB	5	(79.60x51.35x0.8t)	
S CASE C	4	SUS	
FRAME	3	PC	
S CASE A	2	SUS	
TFT-LCD PANEL	001	Glass substrate thickness=0.5t	
PART NAME	ITEM	MATERIAL GRADE	REMARK

APPROVED 木下大輔	GENERAL TOLERANCE ±1.0	SCALE 1/1	UNIT mm	TOPPAN TOPPAN INC. DO NOT DUPLICATE, CONFIDENTIAL AND PROPRIETARY			
CHECKED 加藤真一	ISSUE (Y:M:D) 23:08:25	MODEL COM57H5N32X**					
CHECKED	NAME						
DESIGN 富田恵太	OUTLINE-D5N32			DRAWING No.	REV.	SHEET	DIV.
DRAW 富田恵太				RJD604385D301	#	/	ASS'Y

3.3 Serial Label (S-label)

3.3.1 Display Items

A section : Bar code

B section : Combination of a character

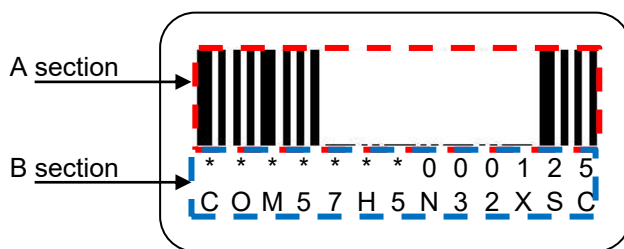

Details of B section

Upper column: It indicates The least significant digit of manufacture year (1 digit), manufacture month with below alphabet (1letter), model code (5characters), serial number (6digits).

* * ***** *****
 — — — —
 a b c d

Contents of display							
a	The least significant digit of manufacture year						
b	Manufacture month	Jan-A	Mar-C	May-E	Jul-G	Sep-I	Nov-K
		Feb-B	Apr-D	Jun-F	Aug-H	Oct-J	Dec-L
c	Model code	57GRC (Made in Japan) 57GSC (Made in Malaysia)					
d	Serial number						

* Example of indication of Serial label (S-label)

•Made in Japan

2L57GRC000125

means "manufactured in December 2022, 5.7" GR type, C specifications, serial number 000125"

•Made in Malaysia

2L57GSC000125

means "manufactured in December 2022, 5.7" GS type, C specifications, serial number 000125"

Lower column: Model (13characters)

3.3.2 Location of Serial Label (S-label)

Refer to 3.2 "Outward Form".

3.3.3 Others

Bar code readability is excluded from quality assurance coverage.

4. Pin Assignment

4.1 Display Module Part

No.	Symbol	Function
1	GND	GND.
2	CLK	Clock signal.Latching data at the falling edge.
3	HSYNC	Horizontal sync signal input.(negative polarity)
4	VSYNC	Vertical sync signal input.(negative polarity)
5	GND	GND.
6	R 0	Display data input for (R). 00h for black display R0:LSB R5:MSB Driver IC carries out gamma conversion internally.
7	R 1	
8	R 2	
9	R 3	
10	R 4	
11	R 5	
12	GND	GND.
13	G 0	Display data input for (G). 00h for black display G0:LSB G5:MSB Driver IC carries out gamma conversion internally.
14	G 1	
15	G 2	
16	G 3	
17	G 4	
18	G 5	
19	GND	GND.
20	B 0	Display data input for (B). 00h for black display B0:LSB B5:MSB Driver IC carries out gamma conversion internally.
21	B 1	
22	B 2	
23	B 3	
24	B 4	
25	B 5	
26	GND	GND.
27	ENAB	Input data effective signal. (It is effective for the period of "Hi")
28	VDD	Power supply input.
29	VDD	Power supply input.
30	RL	Horizontally Flipped (right/left) Signal. (Lo: Horizontally Flipped Display, Hi: Normal display) NOTE1
31	UD	Vertically Flipped (up/down) Signal. (Lo: Normal display,Hi: Vertically Flipped Display) NOTE1
32	DISP	Display on/off control signal.(Lo: display off, Hi: display on) NOTE2
33	GND	GND.

- Used connector : KYOCERA 6240 series [04 6240 033 023 846+]
- Please refer to the section "3.2 Outward Form" for pin terminal order.
- The corrosion phenomenon by the different kind metal uniting is generated according to the system requirements, and there is a possibility of becoming a loose connection.
Please select very carefully, and design the FPC cable used.
- NOTE1: If not use , Please let it no connected.
- NOTE2 : If not use , Please let it connected to VDD.

4.2 Backlight Part

No.	Symbol	Function
1	BLL2	Backlight drive 2 (cathode side).
2	BLL1	Backlight drive 1 (cathode side).
3	BLH2	Backlight drive 2 (anode side).
4	BLH1	Backlight drive 1 (anode side).

- Used connector: JST [SM04B-SRSS-G-TB(LF)(SN)]
- Please refer to the section "3.2 Outward Form" for pin terminal order.
- The corrosion phenomenon by the different kind metal uniting is generated according to the system requirements, and there is a possibility of becoming a loose connection.
Please select very carefully, and design the contact used.

5. Block Diagram

Each arrow shows signal flow.

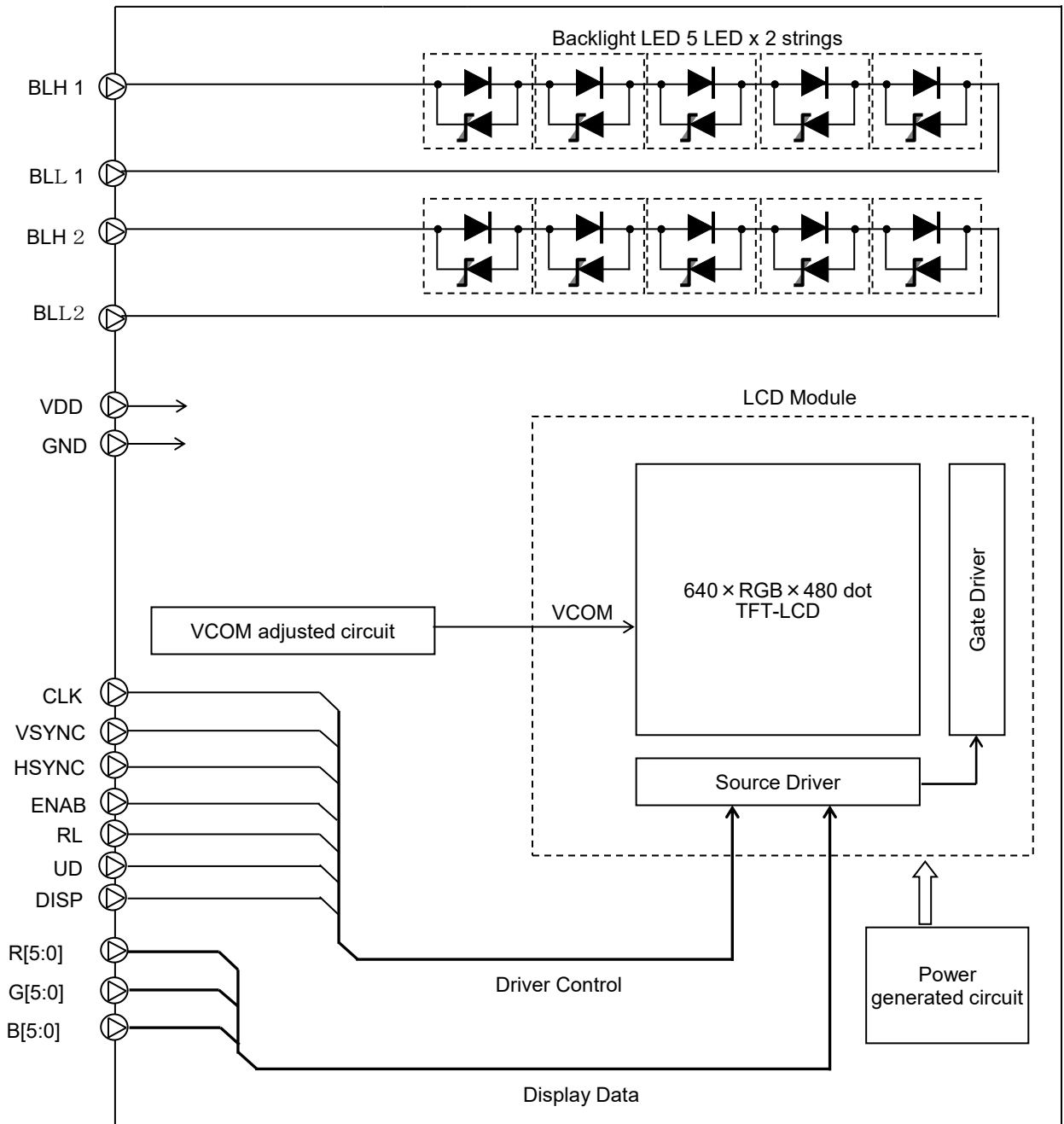

6. Absolute Maximum Rating

GND=0V

Item	Symbol	Condition	Rating		Unit	Applicable terminal
			MIN	MAX		
Supply voltage	VDD	Ta=25°C	-0.3	6.0	V	VDD
Input voltage for logic	VI		-0.3	VDD+0.3	V	CLK,VSYNC,HSYNC,ENAB B[5:0],G[5:0],R[5:0], RL,UD,DISP
LED forward current	IL		--	70	mA	BLH1-BLL1,BLH2-BLL2
Storage temperature range	Tstg		-30	80	°C	
Storage humidity range	Hstg	Non condensing in an environmental moisture at or less than 40°C90%RH.				

Note: Please input the logic signal after turning on VDD. Do not input the logic signal while blocking VDD.

Absolute maximum ratings is parametric values, should never be exceed any value at any moment.

Beyond which, it could be suffered from changes in characteristics and never be restored.

Moreover, it could even be suffered from permanent destruction.

Therefore, please note enough the fluctuation of input voltage, the characteristics of connected parts,

I/O signal line surge, and ambient temperature, on designing the circuit.

7. Recommended Operating Conditions

GND=0V

Item	Symbol	Condition	Rating			Unit	Applicable terminal
			MIN	TYP	MAX		
Supply voltage	VDD		3.0	3.3	3.6	V	VDD
Input voltage for logic	VI	VDD=3.0~ 3.6V	0	--	VDD	V	CLK,VSYNC, HSYNC,B[5:0], G[5:0],R[5:0], ENAB,RL,UD,DISP
Operating temperature range	Top	Note1,2	-20	25	70	°C	Panel surface temperature
Operating humidity range	Hop	Ta≤40°C	20	--	85	%	
		Ta>40°C	Non condensing in an environmental moisture at or less than 40°C85%RH.				

Note1: The temperature within the display will increase due to the heat radiated from the back light while in operation.

Necessary measures have to be taken in the product design to make sure that the display has proper ventilation so that temperature on any surface of this display should not exceed 70°C.

Note2: This monitor is operatable in this temperature range. With regard to optical characteristics, refer to Item "10. Characteristics".

8. Electrical Characteristics

8.1 DC Characteristics

△ 8.1.1 Display Module

(Unless otherwise noted, Ta=25°C, VDD=3.3V, GND=0V)

Item	Symbol	Condition	Rating			Unit	Applicable terminal
			MIN	TYP	MAX		
Input voltage for logic	VIH		0.7×VDD	--	VDD	V	CLK, VSYNC, HSYNC, ENAB, B[5:0], G[5:0], R[5:0], RL, UD, DISP
	VIL		0	--	0.3×VDD	V	
Pull down resister value	Rpd		300	450	600	kΩ	ENAB, B[5:0], G[5:0], R[5:0]
Pull up resister value	Rpu		300	450	600	kΩ	DISP
Current consumption	IDD	fCLK=25MHz Color bar display	--	165	330	mA	VDD

△ 8.1.2 Backlight

Item	Symbol	Condition	Rating			Unit	Applicable terminal
			MIN	TYP	MAX		
Forward current	IL	Ta=25°C	--	26.2	70	mA	BLH1 – BLL1
Forward voltage *Reference only	VL	Ta=25°C, IL= 26.2 mA	12.55	13.85	15.80	V	BLH2 – BLL2
Estimated Life of LED	LL	Ta=25°C, IL= 26.2 mA Note	--	70,000	--	hrs	

Note: - The lifetime of the LED is defined as a period till the brightness of the LED decreases to the half of its initial value.

- This figure is given as a reference purpose only, and not as a guarantee.
 - This figure is estimated for an LED operating alone.
- As the performance of an LED may differ when assembled as a monitor.
- Estimated lifetime could vary on a different temperature and usually higher temperature could reduce the life significantly.

8.2 AC Characteristics

(Unless otherwise noted, Ta=25°C, VDD=3.3V, GND=0V)

Item	Symbol	Condition	Rating			Unit	Applicable terminal
			MIN	TYP	MAX		
CLK frequency	fCLK		--	25	27	MHz	CLK
CLK Low period	tw1L	0.3×VDD or less	14.8	--	--	ns	CLK
CLK High period	tw1H	0.7×VDD or more	14.8	--	--	ns	CLK
Setup time	tsp		10	--	--	ns	CLK, ENAB, B[5:0], G[5:0], R[5:0], HSYNC, VSYNC
Hold time	thd		10	--	--	ns	

Switching Waveform Characteristics

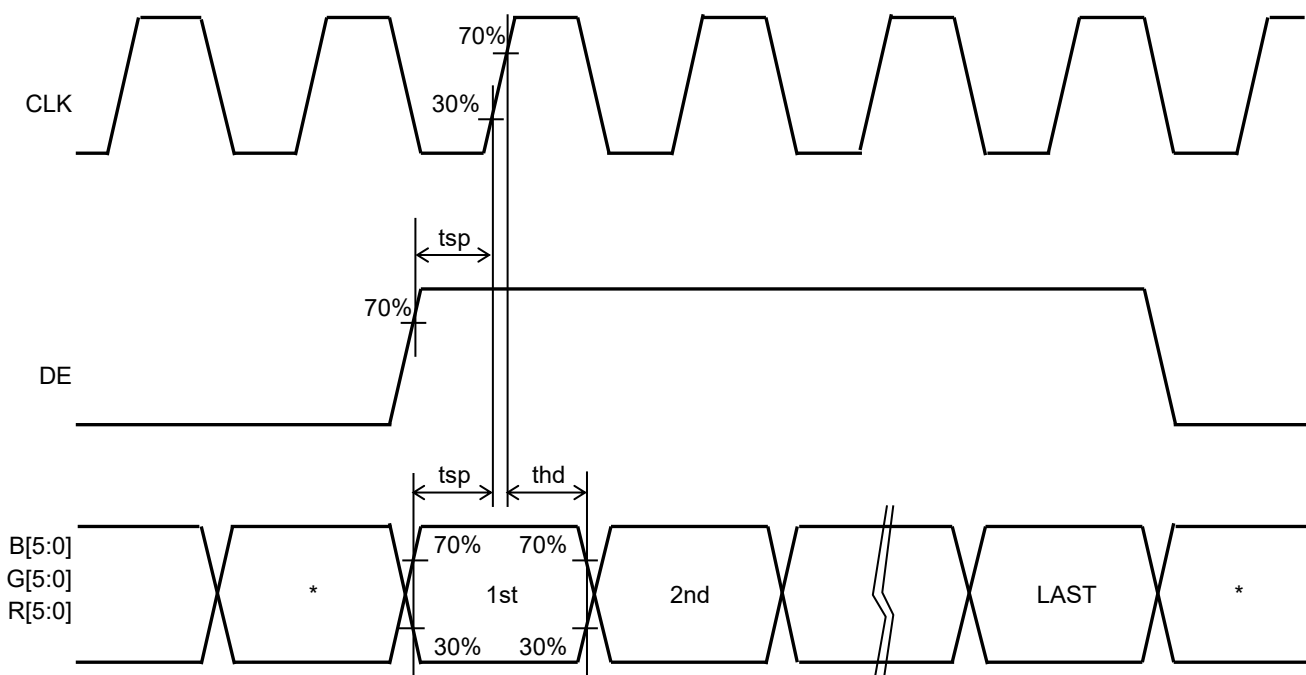
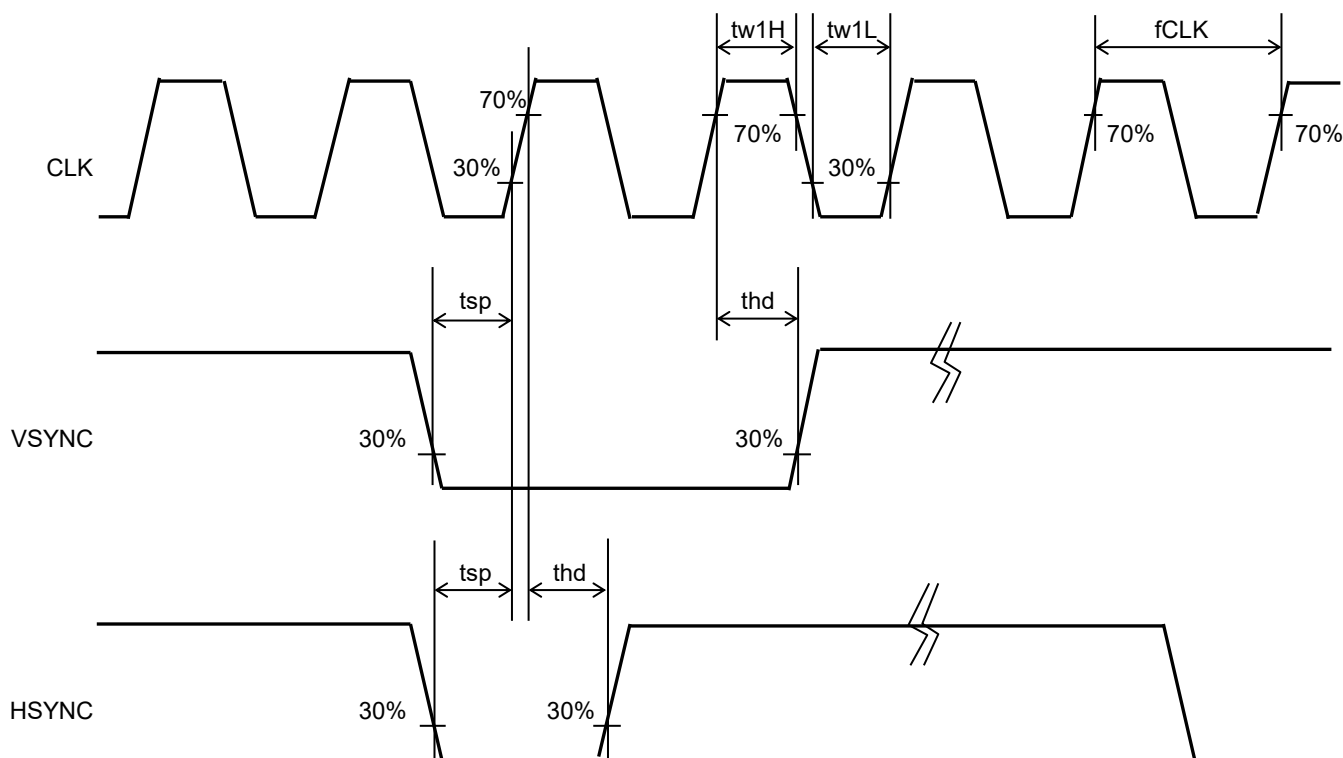

*:INVALID

8.3 Input Timing Characteristics

Item	Symbol	Rating			Unit	Applicable terminal
		MIN	TYP	MAX		
CLK frequency	fCLK	--	25	27	MHz	CLK
VSYNC signal cycle time	tv	--	525	--	H	VSYNC,HSYNC
VSYNC frequency	fVSYNC	54	60	66	Hz	VSYNC
VSYNC pulse width	tw2H	1	3	5	H	VSYNC,HSYNC
Vertical back porch	tvb	--	35	--	H	VSYNC,HSYNC,ENAB,B[5:0],
Vertical display period	tvdp	--	480	--	H	G[5:0],R[5:0]
HSYNC signal cycle time	th	--	800	--	CLK	HSYNC,CLK
HSYNC pulse width	tw3H	5	30	--	CLK	
Horizontal back porch	thb	112	--	144	CLK	HSYNC,CLK,ENAB,B[5:0],
				Note 2		G[5:0],R[5:0]
Horizontal display period	thdp	--	640	--	CLK	
DE pulse width	tw4H	--	640	--	CLK	ENAB,CLK

Note1: The characteristic of this item is recommended standard.

Please use it after it confirms it enough like the display fineness etc.

When it comes off from this characteristic and it is used.

Note2: When "ENAB" keeps "Lo" for 144CLK or longer,start capturing data automatically from 144CLK.

8.4 Driving Timing Chart

-Vertical Timing

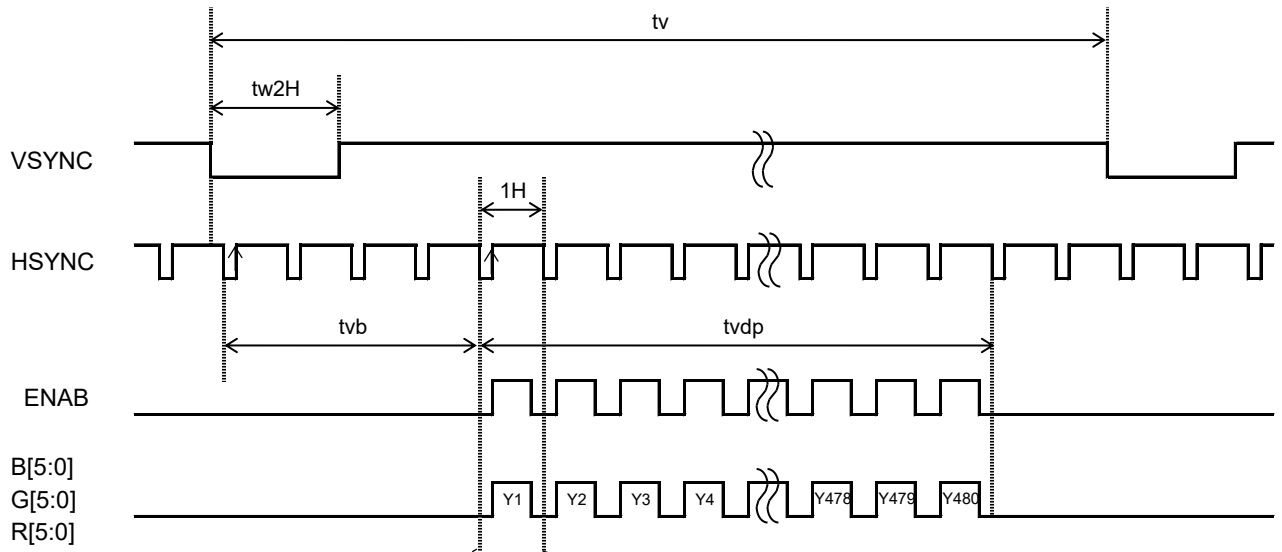

-Horizontal Timing

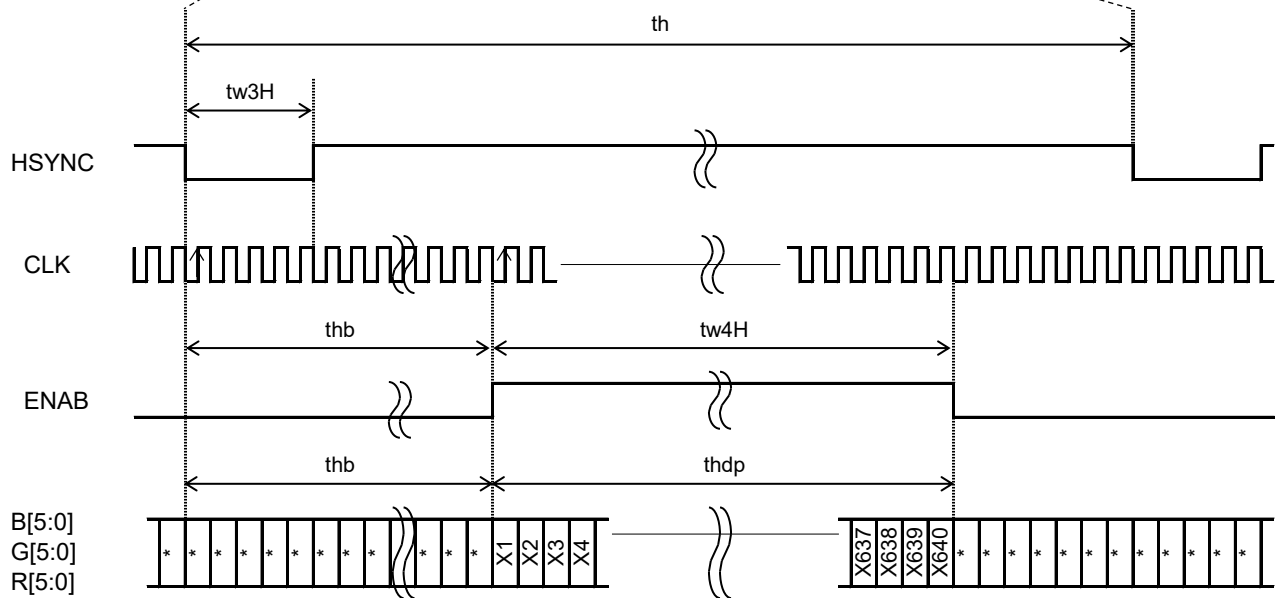

8.5 Example of Driving Timing Chart (fCLK=25MHz)

-Vertical Timing

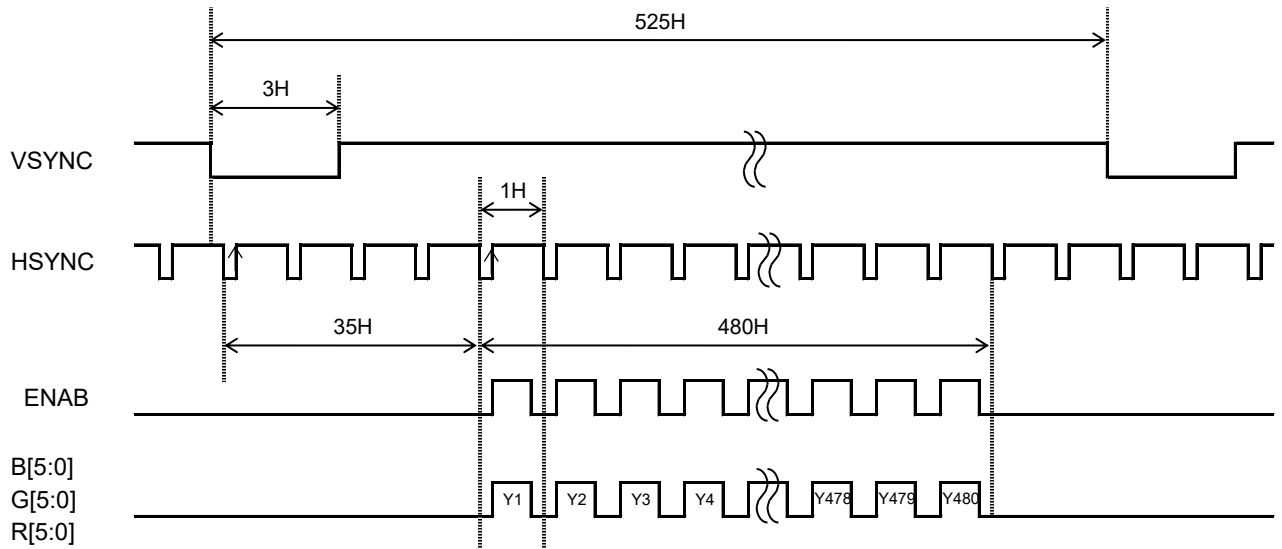

-Horizontal Timing

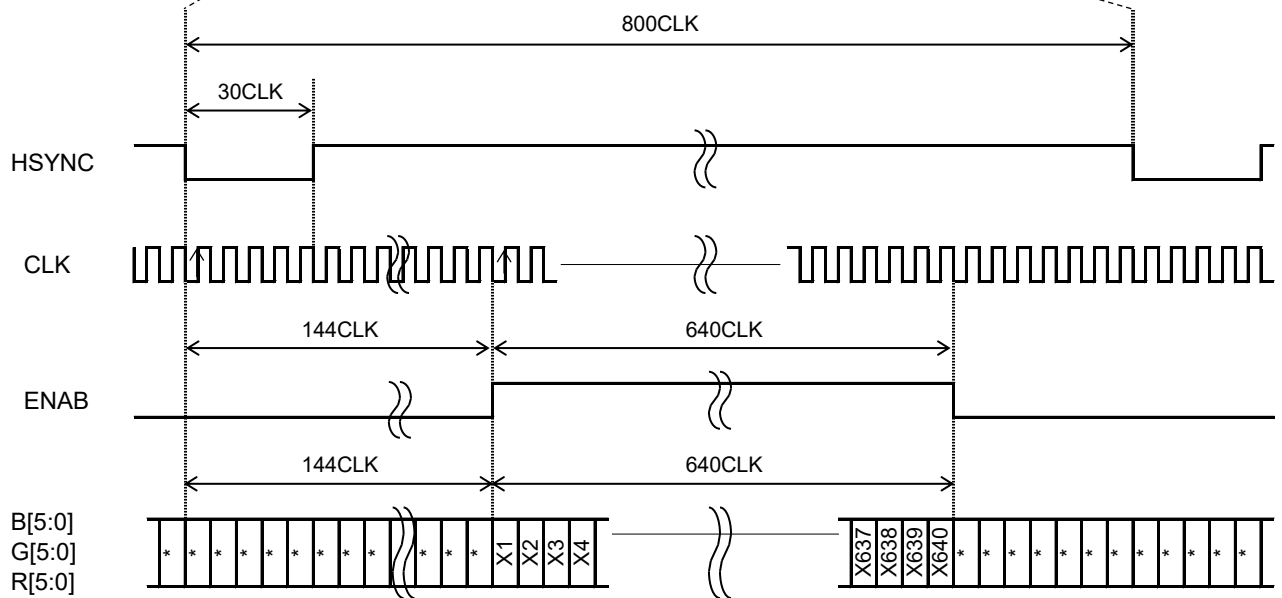

9. "DISP" on/off Sequence

It explains the Display on/off sequence.

After Display on, "White" data is outputted for 16-Frames first, from the falling edge of the following VSYNC signal.

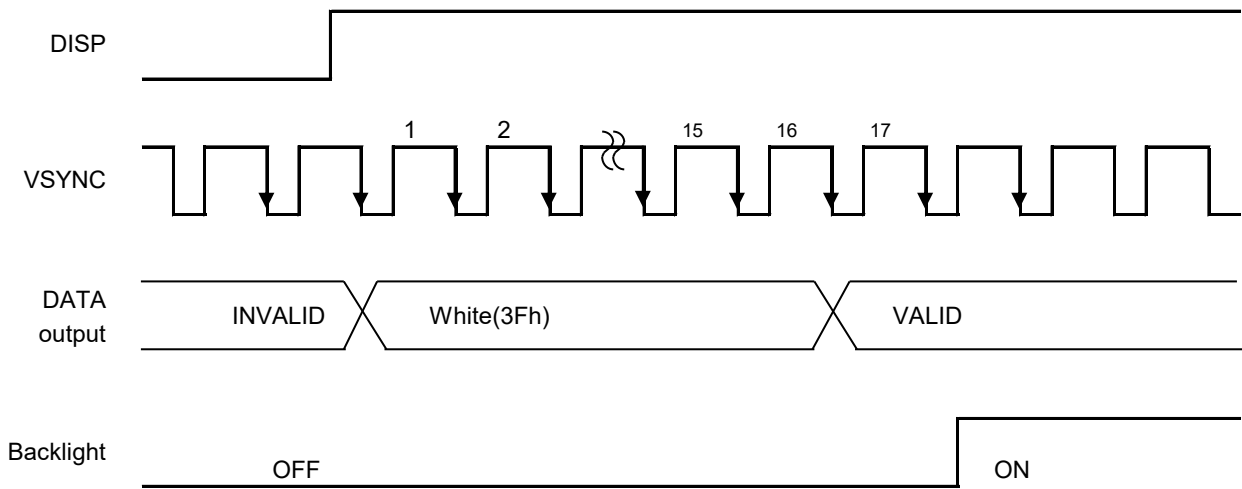

After Display off, "White" data is outputted for 5-Frames first, from the falling edge of the following VSYNC signal. Please turn off the power supply promptly after OFF of "DISP".

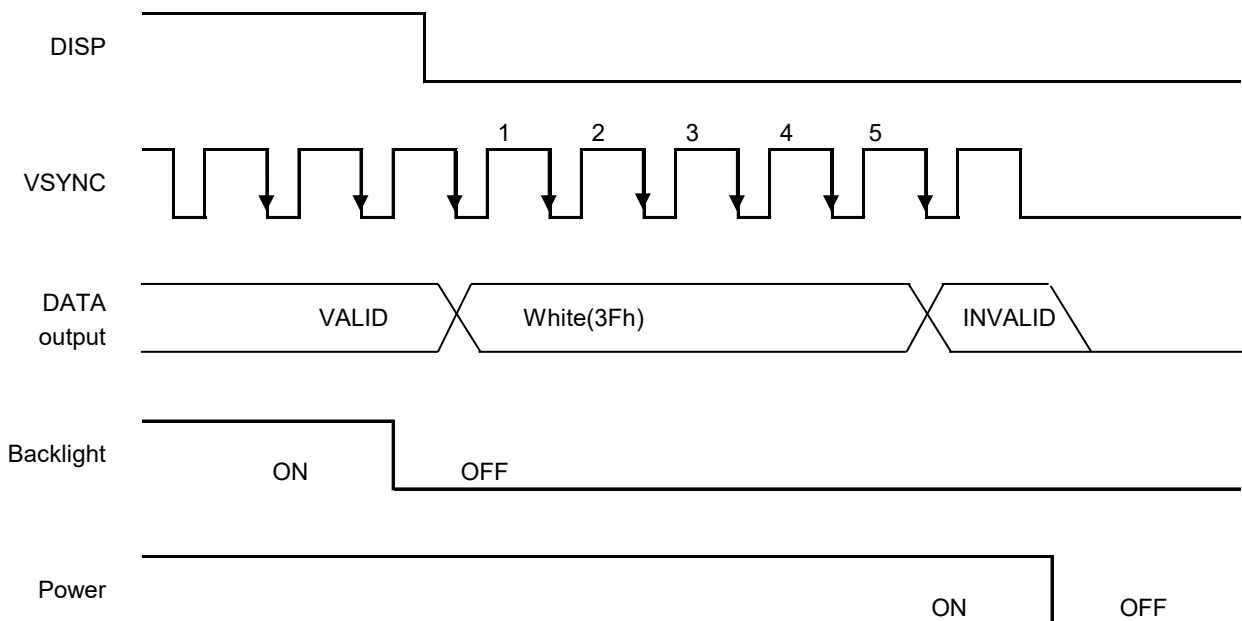

10. Characteristics

 10.1 Optical Characteristics

(Measurement Condition)

Measuring instruments: CS2000 (KONICA MINOLTA), LCD7200 (OTSUKA ELECTRONICS), EZcontrastXL88 (ELDIM)

Driving condition: VDD=3.3V, GND=0V, Optimized VCOMDC

Backlight: IL= 26.2 mA

Measured temperature: Ta = 25°C

Item		Symbol	Condition	MIN	TYP	MAX	Unit	Note №	Remark
Response time	Rise time	TON	[Data]= 00h ← → 3Fh	-	-	100	ms	1	
	+ Fall time	TOFF							
Contrast ratio	Backlight ON	CR	[Data]= 3Fh / 00h	360	600	-		2	
	Backlight OFF			-	4.7	-			
Viewing angle	Left	θL	[Data]= 3Fh / 00h CR \geq 10	-	80	-	deg	3	
	Right	θR		-	80	-	deg		
	Up	φU		-	60	-	deg		
	Down	φD		-	65	-	deg		
White Chromaticity		x y	[Data]= 3Fh	White chromaticity range				4	
Center Brightness			[Data]= 3Fh	310	440	-	cd/m ²	5	
Brightness distribution			[Data]= 3Fh	70	-	-	%	6	
Burn-in				No noticeable burn-in image shall be observed after 2 hours of window pattern display.				7	

* Note number 1 to 7: Refer to the APPENDIX of "Reference Method for Measuring Optical Characteristics and Performance".

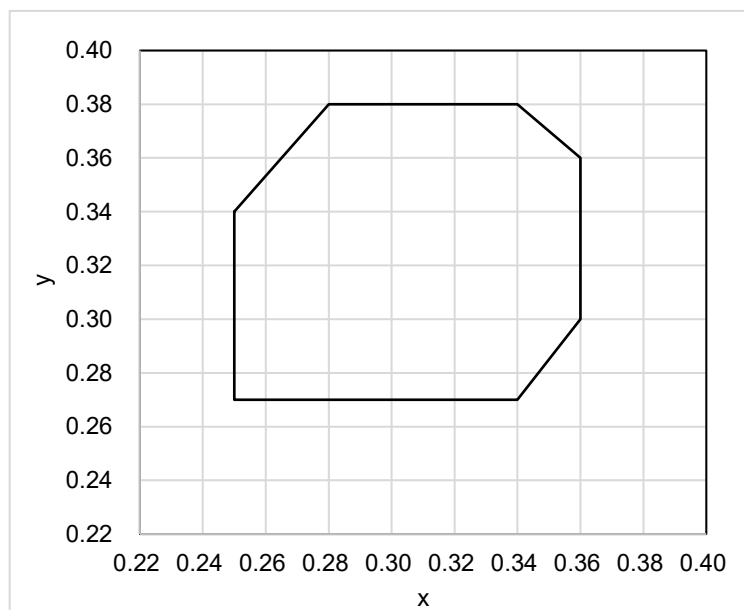

White Chromaticity Range

(White Chromaticity Range)

x	y
0.25	0.34
0.25	0.27
0.34	0.27
0.36	0.30
0.36	0.36
0.34	0.38
0.28	0.38

△ 10.2 Temperature Characteristics

(Measurement Condition)

Measuring instruments: CS2000 (KONICA MINOLTA), LCD7200 (OTSUKA ELECTRONICS)

Driving condition: VDD=3.3V, GND=0V, Optimized VCOMDC

Backlight: IL= 26.2 mA

Item		Symbol	Specification		Remark
			Ta = -20 °C	Ta = 70 °C	
Response time	Rise time + Fall time	TON + TOFF	500 msec or less	80 msec or less	
Contrast ratio		CR	40 or more	40 or more	Backlight ON
Display Quality			No noticeable display defect or ununiformity should be observed.		

11. Criteria of Judgment

 11.1 Defective Display and Screen Quality

Test Condition: Observed TFT-LCD monitor from front during operation with the following conditions

Driving Signal: Raster Patter (RGB, white, black)

Signal condition: [Data]:00h, 18h, 3Fh (3steps)

Observation distance: 30 cm

Illuminance: 200 to 350 lx

Backlight: IL=26.2mA

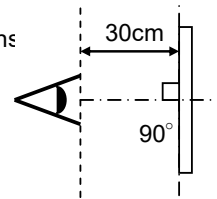

Defect item	Defect content	Criteria		
Display Quality	Line defect	Black, white or color line, 3 or more neighboring defective dots	Not exists	
	Dot defect	Uneven brightness on dot-by-dot base due to defective TFT or CF, or dust is counted as dot defect (brighter dot, darker dot)	Refer to table 1	
		High bright dot: Visible through 2% ND filter at [Data]=00h	Acceptable	
		Low bright dot: Visible through 5% ND filter at [Data]=00h		
	Dark dot: Appear dark through white display at [Data]=18h			
	Invisible through 5% ND filter at [Data]=00h	Acceptable		
Screen Quality	Stain	Uneven brightness (white stain, black stain etc)	Invisible through 1% ND filter.	
	Foreign particle	Point-like	$0.25\text{mm} < \phi$	N=0
			$0.20\text{mm} < \phi \leq 0.25\text{mm}$	$N \leq 2$
			$\phi \leq 0.20\text{mm}$	Acceptable
	Liner	$3.0\text{mm} < L$ and $0.08\text{mm} < W$	N=0	
$L \leq 3.0\text{mm}$ or $W \leq 0.08\text{mm}$		Acceptable		
Others		Use boundary sample for judgment when necessary		

* ϕ (mm): Average diameter = (major axis + minor axis) / 2, W (mm): Width, L (mm): Length, N: Permissible number

Table1

Area	High bright dot	Low bright dot	Dark dot	Total	Criteria
A	0	2	2	3	Permissible distance between same color bright dots (includes neighboring dots): 3 mm or more Permissible distance between same color high bright dots (includes neighboring dots): 5 mm or more
B	2	4	4	6	
Total	2	4	4	7	

<Landscape model>

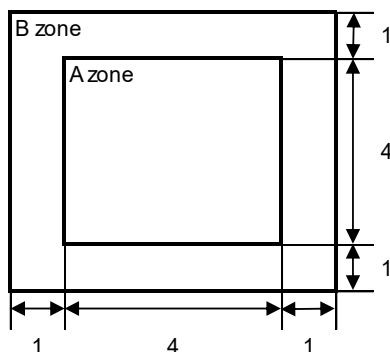

Division of A and B areas

B area: Active area

Dimensional ratio between A and B areas: 1: 4: 1

(Refer to the left figure)

11.2 Screen and Other Appearance

Testing conditions

Observation distance: 30 cm

Illuminance: 1200 ~ 2000 lx

Item		Criteria	Remark
Polarizer	Flaw	Ignore invisible defect when the backlight is on.	Applicable area: Active area only (Refer to the section 3.2 Outward Form)
	Stain		
	Dirt		
	Bubble		
	Dust		
	Dent		
S case		No functional defect occurs	
Connector		No functional defect occurs	



12. Reliability Test

Test item		Test condition		number of failures / number of examinations
Durability test	High temperature storage	Ta = 80°C	240hrs	0 / 3
	Low temperature storage	Ta = -30°C	240hrs	0 / 3
	High temperature & high humidity storage	Ta = 60°C, RH = 90%, non condensing	240hrs	0 / 3
	High temperature operation	Tp = 70°C	240hrs	0 / 3
	Low temperature operation	Tp = -20°C	240hrs	0 / 3
	High temperature & high humidity operation	Tp = 40°C, RH = 90%, non condensing	240hrs	0 / 3
	Thermal shock storage	-30°C ↔ 80°C (30min / 30min)	100cycles	0 / 3
Mechanical environmental test	Surface discharge test (Non operation)	C=250pF, R=100Ω, V=±12kV Each 5 times of discharge in both polarities on the center of screen with the case grounded.		0 / 3
	Vibration test	Total amplitude 1.5mm, f=10~55Hz, X,Y,Z directions for each 2 hours		0 / 3
	Impact test	Use TOPPAN original jig (see next page) and make an impact with peak acceleration of 1000m/s ² for 6 msec with half sine-curve at 3 times to each X, Y, Z directions in conformance with JIS C 60068-2-27-2011.		0 / 3
Packing test	Packing vibration-proof test	Acceleration of 19.6m/s ² with frequency of 10→55→10Hz, X,Y, Z direction for each 30 minutes.		0 / 1 packing
	Packing drop test	Drop from 75cm high. 1 time to each 6 surfaces, 3 edges, 1 corner		0 / 1 packing

Note: Ta=ambient temperature Tp=Panel temperature

※ The profile of high temperature/humidity storage and High Temperature/humidity operation (Pure water of over 10MΩ·cm shall be used.)

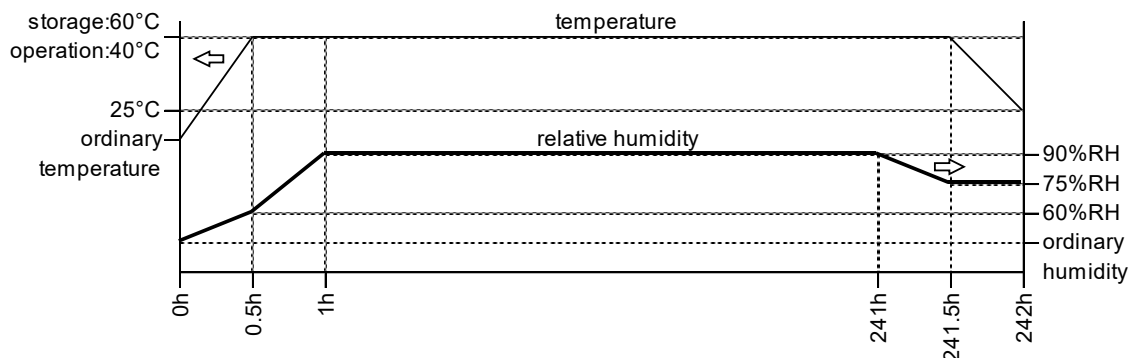
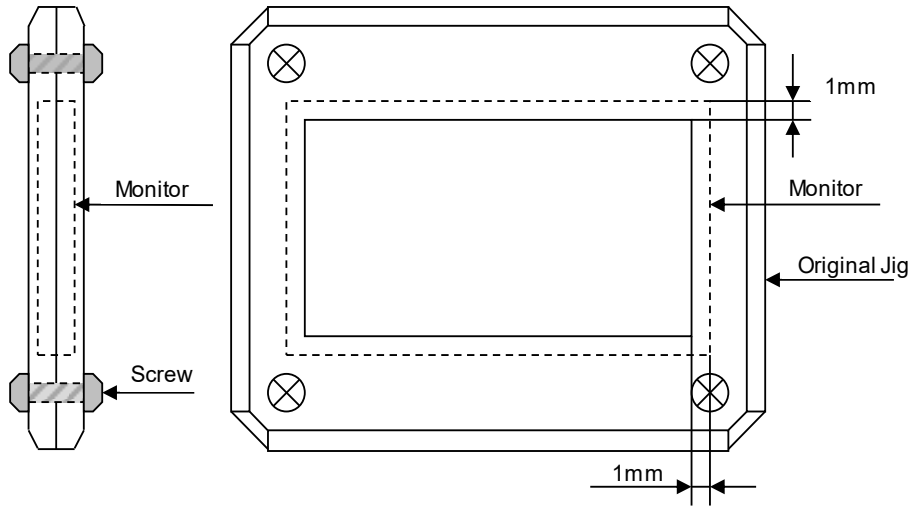

Table2. Reliability Criteria

The parameters should be measured after leaving the monitor at the ordinary temperature for 24 hours or more after the test completion.

Item	Standard	Remark
Display quality	No visible abnormality shall be seen. (Except for unevenness by Pol deterioration.)	
Contrast ratio	40 or more	Backlight ON

TOPPAN Original Jig



13. Packing Specifications

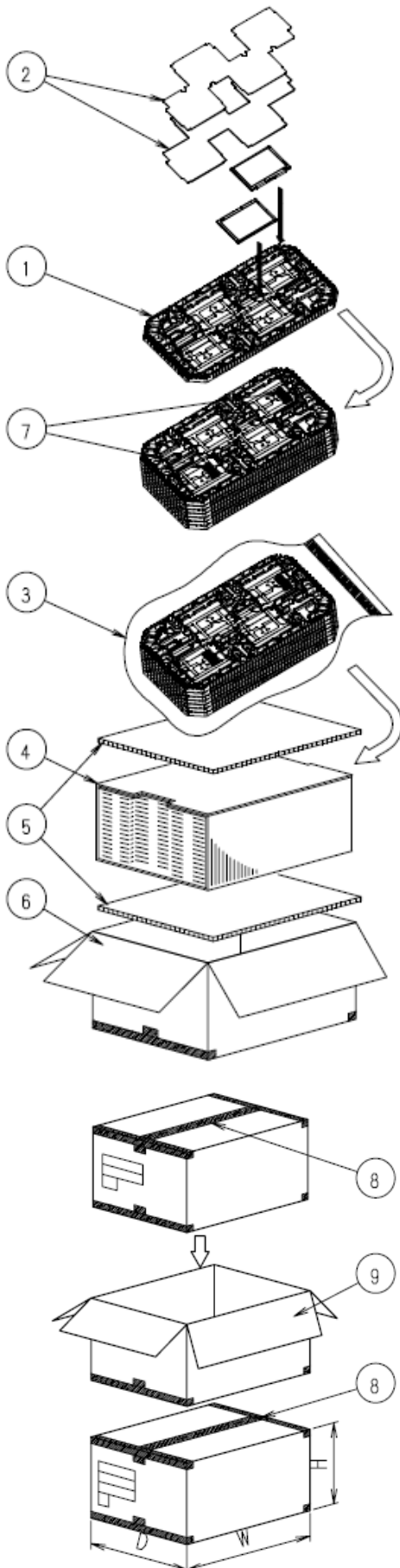

Step.1 Each product is to be placed in one of the cut-outs of the tray with the display surface facing upward.(4products per tray)
Antistatic foam sheet is to be placed on the products in the tray.

Step.2 Each tray needs to be same orientation respect to the tray below or above it and the trays be in a stack of 5.
One empty tray is to be put on the top of stack of 5 trays.

Step.3 2 packs of moisture absorbers are to be placed on the top tray as shown in the drawing.
Put piled trays into a sealing bag.
Vacuum and seal the sealing bag with the vacuum sealing machine.

Step.4 The stack of trays in the plastic back is to be inserted into a inner carton.

Step.5 A corrugated board is to be placed on the top and on the bottom of the inner carton.
The two corrugated boards and the inner carton is to be inserted into an outer carton.

Step.6 The outer carton needs to sealed with packing tape as shown in the drawing.
The model number, quantity of products, and shipping date are to be printed on the outer carton.
If necessary, shipping labels or impression markings are to be put on the outer carton.

Step.7 The outer carton is to be inserted into a extra outer carton with same direction.
The extra outer carton needs to sealed with packing tape as shown in the drawing.

Step.8 The model number, quantity of products, and shipping date are to be printed on the extra outer carton
If necessary, shipping labels or impression markings are to be put on the extra outer carton.

Remark: The return of packing materials is not required.

Packing item name		Specs., Material
①	Tray	A-PET(Antistatic)
②	Foam Sheet	Anti-static polyethylene
③	Sealing Bag	
④	Inner Carton	Corrugated cardboard
⑤	Inner Board	Corrugated cardboard
⑥	Outer Carton	Corrugated cardboard
⑦	Drier	Moisture absorber
⑧	Packing Tape	
⑨	Extra Outer Carton	Corrugated cardboard

Dimension of extra outer carton	
D : Approx.	(338 mm)
W : Approx.	(549 mm)
H : Approx.	(498 mm)
Quantity of products packed in one carton:	4 pcs x 5 = 20pcs
Gross weight : Approx.	5.9 kg

14. Handling Instruction

14.1 Cautions for Handling LCD panels



Caution

- (1) Do not make an impact on the LCD panel glass because it may break and you may get injured from it.
 - (2) If the glass breaks, do not touch it with bare hands.
(Fragment of broken glass may stick you or you cut yourself on it.)
 - (3) If you get injured, receive adequate first aid and consult a medical doctor.
 - (4) Do not let liquid crystal get into your mouth.
(If the LCD panel glass breaks, try not let liquid crystal get into your mouth even toxic property of liquid crystal has not been confirmed.)
 - (5) If liquid crystal adheres, rinse it out thoroughly.
(If liquid crystal adheres to your cloth or skin, wipe it off with rubbing alcohol or wash it thoroughly with soap. If liquid crystal gets into eyes, rinse it with clean water for at least 15 minutes and consult an eye doctor.)
- If you scrap this products, follow a disposal standard of industrial waste
- (6) that is legally valid in the community, country or territory where you reside.
 - (7) Do not connect or disconnect this product while its application products is powered on.
 - (8) Do not attempt to disassemble or modify this product as it is precision component.
 - (9) If a part of soldering part has been exposed, and avoid contact (short-circuit) with a metallic part of the case etc. about Circuit board of this model, please.
Please insulate it with the insulating tape etc. if necessary.
The defective operation is caused, and there is a possibility to generation of heat and the ignition.
 - (10) For protection your circuit, we recommend you to add excess current protection circuit to power supply.

Caution



This mark is used to indicate a precaution or an instruction which, if not correctly observed, may result in bodily injury, or material damages alone.

14.2 Precautions for Handling

- 1) Wear finger tips at incoming inspection and for handling the TFT monitors to keep display quality and keep the working area clean.
Do not touch the surface of the monitor as it is easily scratched.
- 2) Wear grounded wrist-straps and use electrostatic neutralization blowers to prevent static charge and discharge when handling the TFT monitors as the LED in this TFT monitors is damageable to electrostatic discharge.
Designate an appropriate operating area, and set equipment, tools, and machines properly when handling this product.
- 3) Avoid strong mechanical shock including knocking, hitting or dropping to the TFT monitors for protecting their glass parts.
Do not use the TFT monitors that have been experienced dropping or strong mechanical shock.
- 4) Do not use or storage the TFT monitors at high temperature and high humidity environment.
Particularly, never use or storage the TFT monitors at a location where condensation builds up.
- 5) Avoid using and storing TFT monitors at a location where they are exposed to direct sunlight or ultraviolet rays to prevent the LCD panels from deterioration by ultraviolet rays.
- 6) Do not stain or damage the contacts of the Connector
FPC cable needs to be inserted until it can reach to the end of connector slot.
During insertion, make sure to keep the cable in a horizontal position to avoid an oblique insertion.
Otherwise, it may cause poor contact or deteriorate reliability of the Connector.
- 7) Peel off the protective film on the TFT monitors during mounting process.
Refer to the section 14.5 on how to peel off the protective film.
We are not responsible for electrostatic discharge failures or other defects occur when peeling off the protective film.
- 8) The volume attached to the monitor is set to the optimal value at the time of shipment from our factory, so please do not change it.

14.3 Precautions for Operation

- 1) Since this TFT monitors are not equipped with light shielding for the driver IC, do not expose the driver IC to strong lights during operation as it may cause functional failures.
- 2) In case of powering up or powering off this LCD module, be sure to comply the sequence as instructed in this specification.
- 3) Do not plug in or out the FPC cable while power supply is switch on.
Plug the FPC cable in and out while power supply is switched off.
- 4) Do not operate the TFT monitors in the strong magnetic field. It may break the TFT monitors.
- 5) Do not display a fixed image on the screen for a long time.
Use a screen-saver or other measures to avoid a fixed image displayed on the screen for a long time.
Otherwise, it may cause burn-in image on the screen due the characteristics of liquid crystal.

14.4 Storage Condition for Shipping Cartons

(Storage environment)

- Temperature 0 to 40° C
- Humidity 60%RH or less
No-condensing occurs under low temperature with high humidity condition.
- Atmosphere No poisonous gas that can erode electronic components and/or wiring materials should be detected.
- Time period 1 year
- Unpacking To prevent damages caused by static electricity, anti-static precautionary measures (e.g. earthing, anti-static mat) should be implemented.
After unpack, keep product in the appropriate condition, otherwise bubble seal of Protective film may be printed on Polarizer.
- Maximum piling up 8 cartons (excluding the bottom)

*Conditions to storage after unpacking

(Storage environment)

- Temperature 0 to 40° C
- Humidity 60%RH or less
No-condensing occurs under low temperature with high humidity condition.
- Atmosphere No poisonous gas that can erode electronic components and/or wiring materials should be detected.
- Time period 1 year (Shelf life)
- Others Keep/ store away from direct sunlight
Storage goods on original tray made by TOPPAN.

14.5 Precautions for Peeling off the Protective film

The followings work environment and work method are recommended to prevent the TFT monitors from static damage or adhesion of dust when peeling off the protective films.

A) Work Environment

- a) Humidity: 50 to 70 %RH, Temperature 15 to 27° C
- b) Operators should wear conductive shoes, conductive clothes, conductive finger tips and grounded wrist-straps.
Use an electrostatic neutralization blower.
- c) Anti-static treatment should be implemented to work area's floor.
Use a room shielded against outside dust with sticky floor mat laid at the entrance to eliminate dirt.

B) Work Method

The following procedures should taken to prevent the driver ICs from charging and discharging.

- a) Use an electrostatic neutralization blower to blow air on the TFT monitors to its lower left when FPC is placed at the bottom.
Optimize direction of the blowing air and the distance between the TFT monitors and the electrostatic neutralization blower.
- b) Put an adhesive tape (Scotch tape, etc) at the lower left corner area of the protective film to prevent scratch on surface of TFT monitors.
- c) Peel off the adhesive tape slowly (spending more than 2 secs to complete) by pulling it to opposite direction.

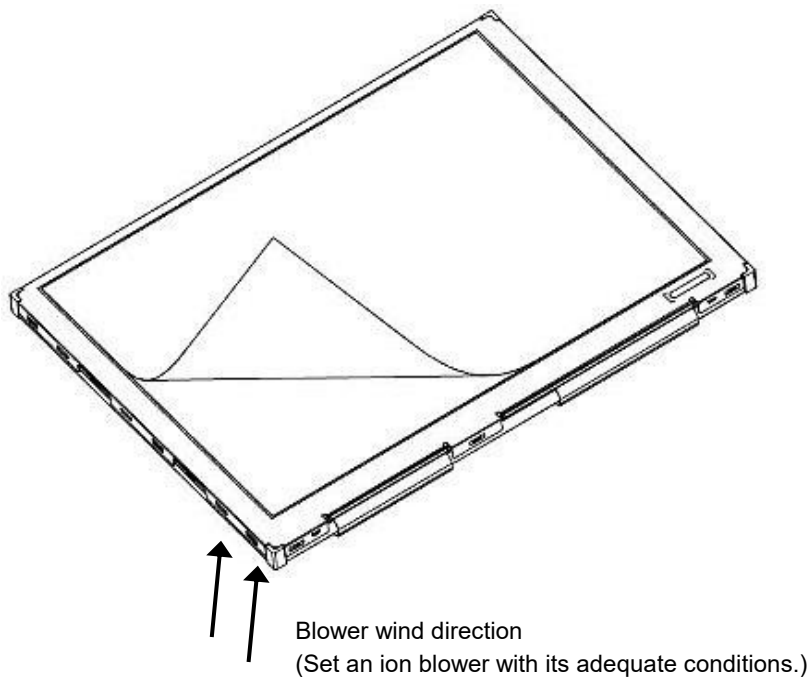

14.6 Warranty

TOPPAN is only liable to defective goods which is stored and used under the condition complying with this specifications and returned within 1 (one) year.

Warranty caused by manufacturing defect shall be conducted by replacement of goods or refundment at unit price.

APPENDIX

Reference Method for Measuring Optical Characteristics and Performance

1. Measurement Condition (Backlight ON)

Measuring instruments: CS2000(KONICA MINOLTA), LCD7200(OTSUKA ELECTRONICS),EZcontrastXL88(ELDIM)

Driving condition: Refer to the section "Optical Characteristics"

Measured temperature: 25°C unless specified

Measurement system: See the chart below. The luminance meter is placed on the normal line of measurement system.

Measurement point: At the center of the screen unless otherwise specified

Dark box at constant temperature

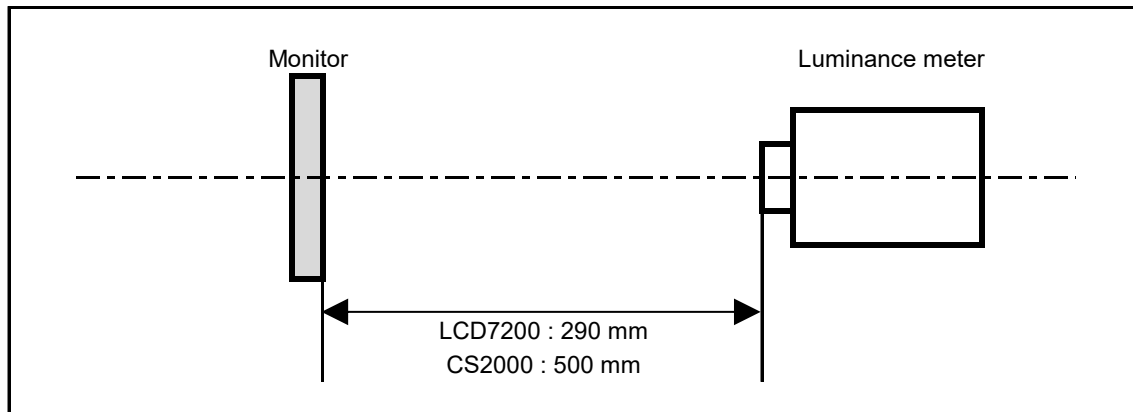

*Measurement is made after 30 minutes of lighting of the backlight.

Measurement point: At the center point of the screen

Brightness distribution: 9 points shown in the following drawing.

<Landscape model>

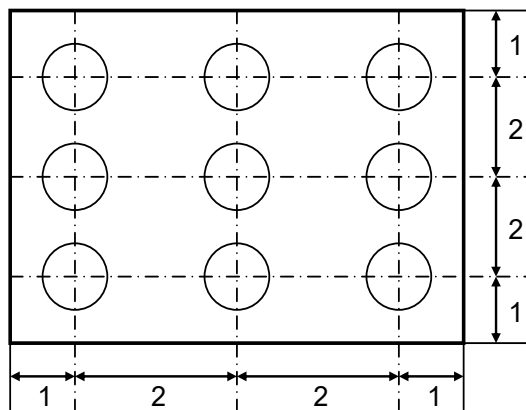

Dimensional ratio of active area

 Backlight IL=26.2mA

Measurement Condition (Contrast ratio Backlight OFF only)

Measuring instruments: LCD7200(OTSUKA ELECTRONICS) , Ring Light (40,000 lx, $\phi 58$)

Driving condition: Refer to the section "Optical Characteristics"

Measured temperature: 25°C unless specified

Measurement system: See the chart below.

Measurement point: At the center of the screen unless otherwise specified

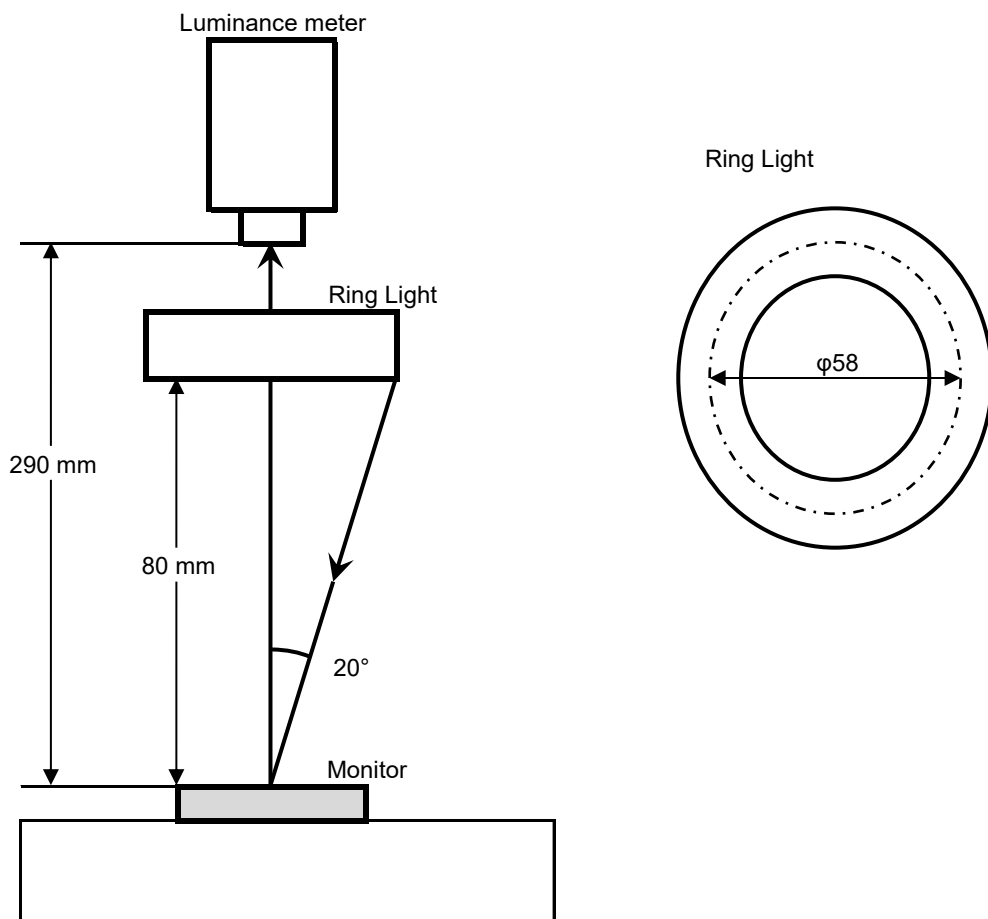

2. Test Method

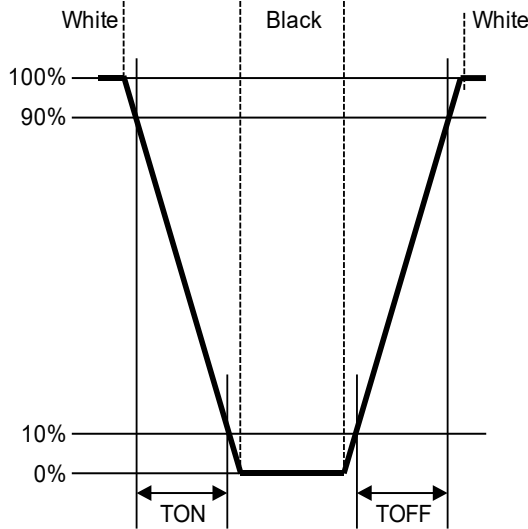
Notice	Item	Test method	Measuring instrument	Remark
1	Response time	<p>Measure output signal waveform by the luminance meter when raster of window pattern is changed from white to black and from black to white.</p> 	LCD7200	Black display [Data]=00h White display [Data]=3Fh TON Rise time TOFF Fall time
2	Contrast ratio	<p>Measure maximum luminance Y1([Data]=3Fh) and minimum luminance Y2([Data]=00h) at the center of the screen by displaying raster or window pattern. Then calculate the ratio between these two values.</p> <p>Contrast ratio = $Y1/Y2$</p> <p>Diameter of measuring point: 7.8mmφ(CS2000) Diameter of measuring point: 3mmφ(LCD7200)</p>	CS2000 LCD7200	Backlight ON Backlight OFF
3	Viewing angle Horizontalθ Verticalφ	Move the luminance meter from right to left and up and down and determine the angles where contrast ratio is 10.	EZcontrastXL88	
4	White chromaticity	<p>Measure chromaticity coordinates x and y of CIE1931 colorimetric system at [Data] = 3Fh</p> <p>Color matching function: 2°view measurement angle: 1°</p>	CS2000	
5	Center brightness	Measure the brightness at the center of the screen.	CS2000	
6	Brightness distribution	<p>(Brightness distribution) = $100 \times B/A \%$</p> <p>A : max. brightness of the 9 points B : min. brightness of the 9 points</p>	CS2000	
7	Burn-in	Visually check burn-in image on the screen after 2 hours of "window display" ([Data]=00h/3Fh).		At optimized VCOMDC

DATA MODUL



ALL TECHNOLOGIES. ALL COMPETENCIES. ONE SPECIALIST.



DATA MODUL AG
Landsberger Straße 322
DE-80687 Munich
Phone: +49 89 56017 0

DATA MODUL WEIKERSHEIM GMBH
Lindenstraße 8
DE-97990 Weikersheim
Phone: +49 7934 101 0

