



SPECIFICATION

BOE

DV220X2M-NV0

22" – square – LVDS

Version: Rev.P1
Date: 16.02.2022

Note: This specification is subject to change without prior notice

TITLE : DV220X2M-NV0
Final Product Specification
Rev. P1

BEIJING BOE Display TECHNOLOGY

SPEC. NUMBER

PRODUCT GROUP

Rev. P1

ISSUE DATE

PAGE

TFT LCD

2018.07.18

1 OF 30

REVISION HISTORY

() preliminary specification

(●) Final specification

Revision No.	Page	Description of changes	Date	Prepared
Rev.P0		Initial Release	June.27.2018	Tian Ming
Rev.P1	30	Add Riveting column height	July.18.2018	Tian Ming

Contents

No.	Item	Page
1.0	General Description	4
2.0	Absolute Maximum Ratings	6
3.0	Electrical Specifications	7
4.0	Optical Specifications	8
5.0	Interface Connection	10
6.0	Signal Timing Specifications	14
7.0	Signal Timing Waveforms of Interface Signal	16
8.0	Input Signals, Display Colors & Gray Scale of Colors	18
9.0	Power Sequence	19
10.0	Mechanical Characteristics	20
11.0	Reliability Test	21
12.0	Handling & Cautions	22
13.0	Product Serial Number	23
14.0	Packing	24
15.0	Appendix	27

1.0 GENERAL DESCRIPTION

1.1 Introduction

DV220X2M-NV0 is a color active matrix TFT LCD module using amorphous silicon TFT's (Thin Film Transistors) as an active switching devices. This module has a 22 inch diagonally measured active area with 2K resolutions (1920 horizontal by 1920 vertical pixel array). Each pixel is divided into RED, GREEN, BLUE dots which are arranged in vertical stripe and this module can display 16.7M colors. The TFT-LCD panel used for this module is adapted for a low reflection and higher color type.

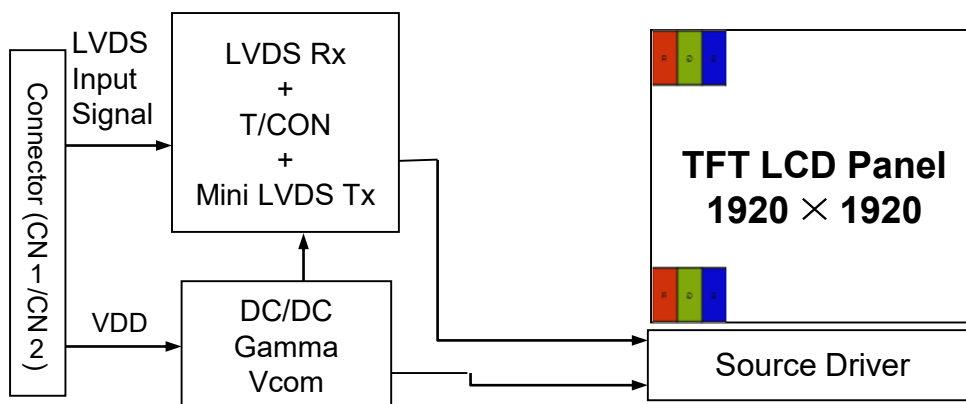

1.2 Features

- LVDS Interface with 4 pixel / clock (Jeida Format)
- High-speed response
- 0.5t Glass
- 8-bit color depth, display 16.7M colors
- Incorporated edge type back-light (One Light Bar)
- High luminance and contrast ratio, low reflection and wide viewing angle
- DE (Data Enable) only
- RoHS/Halogen Free
- Gamma Correction
- Reverse type

1.3 Application

- Desktop Type of PC & Workstation Use
- Slim-Size Display for Stand-alone Monitor
- Display Terminals for Control System
- Monitors for Process Controller

1.4 General Specification

The followings are general specifications at the model DV220X2M-NV0.

<Table 1. General Specifications>

Parameter	Specification	Unit	Remarks
Active area	394.56(H) × 394.56(V)	mm	
Number of pixels	1920(H) × 1920(V)	pixels	
Pixel pitch	0.0685(H) x 0.2055(V)	mm	
Pixel arrangement	RGB Vertical stripe	-	
Display colors	16.7M	colors	
Display mode	Normally Black	-	
Dimensional outline	409.56(H) × 409.56(V) × 7.6(D) typ	mm	Detail refer to drawing
Weight	1.96 ± 0.1	Kg	
Surface Treatment	AG 25%, 3H	-	
Back-light	Right side 1-LED Light bar Type	-	

2.0 ABSOLUTE MAXIMUM RATINGS

The followings are maximum values which, if exceed, may cause faulty operation or damage to the unit. The operational and non-operational maximum voltage and current values are listed in Table 2.

< Table 2. Absolute Maximum Ratings >

[VSS=GND=0V]

Parameter	Symbol	Min.	Max.	Unit	Remarks
Power Supply Voltage	V_{DD}	3.5	5.5	V	Ta = 25 °C
Logic Supply Voltage	V_{IN}	VSS-0.3	$V_{DD}+0.3$	V	
Operating Temperature	T_{OP}	0	+50	°C	1)
Storage Temperature	T_{ST}	-20	+60	°C	1)
LCM Surface Temperature (Operation)	$T_{surface}$	0	+65	°C	2)

Note : 1) Temperature and relative humidity range are shown in the figure below.

Wet bulb temperature should be 39 °C max. and no condensation of water.

2) LCM Surface Temperature should be Min. 0°C and Max. 65°C under the VLCD=5.0V, fV=60Hz, 25°C ambient Temp. No humidity control and LED string current is typical Value.

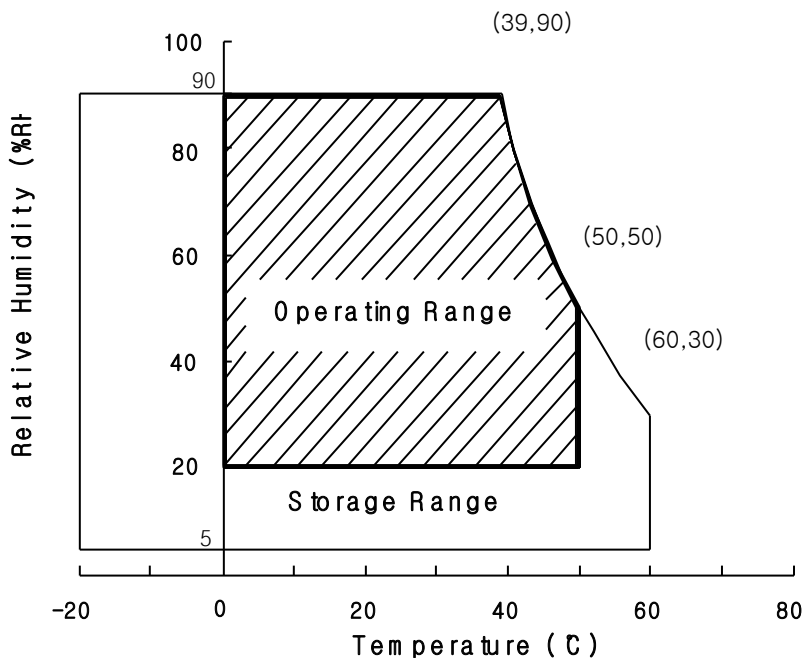

3.0 ELECTRICAL SPECIFICATIONS

3.1 Electrical Specifications

< Table 3. Electrical specifications >

[Ta = 25 ± 2 °C]

Parameter		Min.	Typ.	Max.	Unit	Remarks
Power Supply Voltage	V _{DD}	3.5	5.0	5.5	V	Note1
Power Supply Current	I _{DD}	-	1100	1400	mA	
In-Rush Current	I _{RUSH}	-	3.0	4	A	Note 2
Permissible Input Ripple Voltage	V _{RF}	-	-	300	mV	V _{DD} = 5.0V
High Level Differential Input Threshold Voltage	V _{IH}	-	-	+100	mV	
Low Level Differential Input Threshold Voltage	V _{IL}	-100	-	-	mV	
Differential input voltage	V _{ID}	100	-	600	mV	
Differential input common mode voltage	V _{cm}	0.7	-	1.6		V _{IH} =100mV, V _{IL} =-100mV
LED Voltage	V _L	2.8	2.9	3.0	V	
LED Channel Voltage	V _L	36.4	37.7	39.0	V	
LED Channel Current	I _L	-	115	-	mA	
LED Lifetime		30,000	-	-	Hrs	I _L =115mA
Power Consumption	P _D		5.5	7.7	W	
	P _{BL}	-	17.3	17.9	W	I _L =115mA, Note 3
	P _{total}	-	22.3	26.7	W	

Notes : 1. The supply voltage is measured and specified at the interface connector of LCM.

The current draw and power consumption specified is for VDD=5.0V, Frame rate=60Hz. Test Pattern of power supply current

- a) Typ : Color Bar pattern
- b) Max : Gray level 255 pattern

2. Duration of rush current is about 2 ms and rising time of VDD is 520 μs ± 20 %

3. Calculated value for reference (V_L × I_L) × 4(channel) excluding driver loss. (LED Light bar: 13S4P)

Parameter		Min.	Typ.	Max.	Unit	Remarks
LED Light Bar Input Voltage Per Input Pin	V _{PIN}	36.4	37.7	39.0	V	Duty 100%
LED Light Bar Input Current Per Input Pin	I _{PIN}	-	115	-	mA	Note1,2,
LED Power Consumption	P _{BL}	-	17.3	17.9	W	Note 3
LED Life-Time	-	30,000	-		Hrs	Note 4

LED bar consists of 52 LED packages,4 strings(parallel)*13packages(serial)

Note1: There are one light bar ,and the specified current is input LED chip 100% duty current

Note2: The sense current of each input pin is 150mA

Note3: $P_{BL}=4 \text{ Input pins} \times V_{PIN} \times I_{PIN}$

Note4: The lifetime is determined as the time at which luminance of LED become 50% of the initial brightness or not normal lighting at I_{PIN}=150mA on condition of continuous operating at 25 ± 2 °C

4.0 OPTICAL SPECIFICATION

4.1 Overview

The test of Optical specifications shall be measured in a dark room (ambient luminance ≤ 1 lux and temperature = $25 \pm 2^\circ\text{C}$) with the equipment of Luminance meter system (Goniometer system and TOPCONE PR730) and test unit shall be located at an approximate distance 50cm from the LCD surface at a viewing angle of θ and Φ equal to 0° . We refer to $\theta_{\theta=0}$ ($=\theta_3$) as the 3 o'clock direction (the "right"), $\theta_{\theta=90}$ ($=\theta_{12}$) as the 12 o'clock direction ("upward"), $\theta_{\theta=180}$ ($=\theta_9$) as the 9 o'clock direction ("left") and $\theta_{\theta=270}$ ($=\theta_6$) as the 6 o'clock direction ("bottom"). While scanning θ and/or Φ , the center of the measuring spot on the Display surface shall stay fixed. The measurement shall be executed after 30 minutes warm-up period. VDD shall be 5.0V +/-10% at 25°C . Optimum viewing angle direction is 6 'clock.

4.2 Optical Specifications

[VDD = 5.0V, Frame rate = 60Hz, Clock = 78MHz, $I_{BL} = 160\text{mA}$, $T_a = 25 \pm 2^\circ\text{C}$]

< Table 4. Module Optical >

Parameter		Symbol	Condition	Min.	Typ.	Max.	Unit	Remark
Viewing Angle range	Horizontal	θ_3	CR > 10	85	89	-	Deg.	Note 1
		θ_9		85	89	-	Deg.	
	Vertical	θ_{12}		85	89	-	Deg.	
		θ_6		85	89	-	Deg.	
Luminance Contrast ratio		CR	$\theta = 0^\circ$ (Center) Normal Viewing Angle	700	1000			Note 2
Luminance of White		Y_w		400	500	-	cd/m ²	Note 3
White luminance uniformity		ΔY		-	75	-	%	Note 4
NTSC Color Gamut		C.G.		-	72	-	%	
Reproduction of color	White	W_x	$\theta = 0^\circ$ (Center) Normal Viewing Angle	0.250	0.280	0.310	-	Note 5
		W_y		0.260	0.290	0.310	-	
	Red	R_x		0.596	0.626	0.656	-	
		R_y		0.311	0.341	0.371	-	
	Green	G_x		0.281	0.311	0.341	-	
		G_y		0.617	0.647	0.677	-	
	Blue	B_x		0.123	0.153	0.183	-	
		B_y		0.024	0.054	0.084	-	
Response Time	GTG	T_g	-	8	10	ms	Note 6	

Note :

- Viewing angle is the angle at which the contrast ratio is greater than 10. The viewing are determined for the horizontal or 3, 9 o'clock direction and the vertical or 6, 12 o'clock direction with respect to the optical axis which is normal to the LCD surface.
- Contrast measurements shall be made at viewing angle of $\theta = 0^\circ$ and at the center of the LCD surface. Luminance shall be measured with all pixels in the view field set first to white, then to the dark (black) state. (See FIGURE 1 shown in Appendix) Luminance Contrast Ratio (CR) is defined mathematically.

$$CR = \frac{\text{Luminance when displaying a white raster}}{\text{Luminance when displaying a black raster}}$$

- Center Luminance of white is defined as the LCD surface. Luminance shall be measured with all pixels in the view field set first to white. This measurement shall be taken at the locations shown in FIGURE 2 for a total of the measurements per display.
- The White luminance uniformity on LCD surface is then expressed as :
 $\Delta Y = (\text{Minimum Luminance of 9points} / \text{Maximum Luminance of 9points}) * 100$
 (See FIGURE 2 shown in Appendix).
- The color chromaticity coordinates specified in Table 5. shall be calculated from the spectral data measured with all pixels first in red, green, blue and white. Measurements shall be made at the center of the panel.
- Response time T_g is the average time required for display transition by switching the input signal as below table and is based on Frame rate $f_V = 60\text{Hz}$ to optimize. Each time in below table is defined as appendix Figure 3 and shall be measured by switching the input signal for "any level of gray(bright)" and "any level of gray(dark)".

Measured Response Time	Target																
	0	15	31	47	63	79	95	111	127	143	159	175	191	207	223	239	255
0																	
15																	
31																	
47																	
63																	
79																	
95																	
111																	
127																	
143																	
159																	
175																	
191																	
207																	
223																	
239																	
255																	

- Cross-Talk of one area of the LCD surface by another shall be measured by comparing the luminance (Y_A) of a 25mm diameter area, with all display pixels set to a gray level, to the luminance (Y_B) of that same area when any adjacent area is driven dark. (See FIGURE 4 shown in Appendix).

5.0 INTERFACE CONNECTION.

5.1 Electrical Interface Connection

5.1.1 LED Light Bar

-LED connector : 3707K-X06X-08X manufactured by E&T

< Table 5. LED Light Bar >

Pin No	Symbol	Description
1	IRLED1	LED current sense for string1
2	IRLED2	LED current sense for string2
3	VLED	LED power supply
4	VLED	LED power supply
5	IRLED3	LED current sense for string3
6	IRLED4	LED current sense for string4

5.2 Electrical Interface Connection

- CN1 Module Side Connector : IS050-C51B-C39-Sor Equivalent

No	Symbol	Function	No	Symbol	Function
1	GND	Power Ground	27	NC	
2	NC		28	CH4_0-	FOURTH_ Negative LVDS differential data input
3	NC		29	CH4_0+	FOURTH_ Positive LVDS differential data input
4	NC		30	CH4_1-	FOURTH_ Negative LVDS differential data input
5	NC		31	CH4_1+	FOURTH_ Positive LVDS differential data input
6	NC		32	CH4_2-	FOURTH_ Negative LVDS differential data input
7	NC		33	CH4_2+	FOURTH_ Positive LVDS differential data input
8	NC		34	GND	Power Ground
9	NC		35	CH4_CLK-	FOURTH_ Negative LVDS differential clock input
10	NC		36	CH4_CLK+	FOURTH_ Positive LVDS differential clock input
11	NC		37	GND	Power Ground
12	CH3_0-	THIRD_ Negative LVDS differential data input	38	CH4_3-	FOURTH_ Negative LVDS differential data input
13	CH3_0+	THIRD_ Positive LVDS differential data input	39	CH4_3+	FOURTH_ Positive LVDS differential data input
14	CH3_1-	THIRD_ Negative LVDS differential data input	40	NC	
15	CH3_1+	THIRD_ Positive LVDS differential data input	41	NC	
16	CH3_2-	THIRD_ Negative LVDS differential data input	42	NC	
17	CH3_2+	THIRD_ Positive LVDS differential data input	43	NC	
18	GND	Power Ground	44	GND	Power Ground
19	CH3_CLK-	THIRD_ Negative LVDS differential clock input	45	GND	Power Ground
20	CH3_CLK+	THIRD_ Positive LVDS differential clock input	46	GND	Power Ground
21	GND	Power Ground	47	NC	
22	CH3_3-	THIRD_ Negative LVDS differential data input	48	VIN	Power +5V
23	CH3_3+	THIRD_ Positive LVDS differential data input	49	VIN	Power +5V
24	NC		50	VIN	Power +5V
25	NC		51	VIN	Power +5V
26	GND	Power Ground			

5.2 Electrical Interface Connection

- CN2 Module Side Connector : IS050-C41B-C39-Sor Equivalent

No	Symbol	Function	No	Symbol	Function
1	NC		22	NC	
2	NC		23	NC	
3	NC		24	GND	Power Ground
4	NC		25	GND	Power Ground
5	NC		26	CH2_0-	SECOND_ Negative LVDS differential data input
6	NC		27	CH2_0+	SECOND_ Positive LVDS differential data input
7	NC		28	CH2_1-	SECOND_ Negative LVDS differential data input
8	NC		29	CH2_1+	SECOND_ Positive LVDS differential data input
9	GND	Power Ground	30	CH2_2-	SECOND_ Negative LVDS differential data input
10	CH1_0-	FIRST_ Negative LVDS differential data input	31	CH2_2+	SECOND_ Positive LVDS differential data input
11	CH1_0+	FIRST_ Positive LVDS differential data input	32	GND	Power Ground
12	CH1_1-	FIRST_ Negative LVDS differential data input	33	CH2_CLK-	SECOND_ Negative LVDS differential clock input
13	CH1_1+	FIRST_ Positive LVDS differential data input	34	CH2_CLK+	SECOND_ Positive LVDS differential clock input
14	CH1_2-	FIRST_ Negative LVDS differential data input	35	GND	Power Ground
15	CH1_2+	FIRST_ Positive LVDS differential data input	36	CH2_3-	SECOND_ Negative LVDS differential data input
16	GND	Power Ground	37	CH2_3+	SECOND_ Positive LVDS differential data input
17	CH1_CLK-	FIRST_ Negative LVDS differential clock input	38	NC	
18	CH1_CLK+	FIRST_ Positive LVDS differential clock input	39	NC	
19	GND	Power Ground	40	GND	Power Ground
20	CH1_3-	FIRST_ Negative LVDS differential data input	41	GND	Power Ground
21	CH1_3+	FIRST_ Positive LVDS differential data input			

5.2 Data Input Format

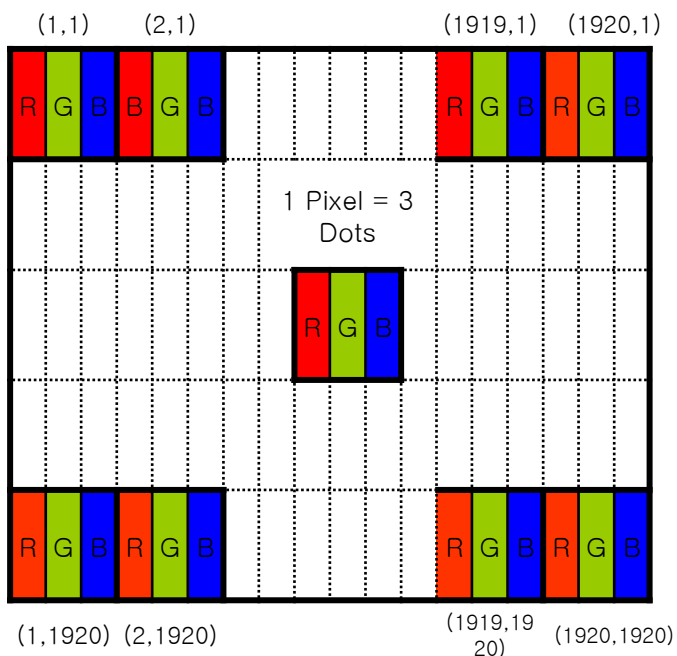

Display Position of Input Data (V-H)

5.3 Back-light Interface Connection

-LED connector : **3707K-X06X-08X** manufactured by **E&T**

Pin	Function
1	Channel 1 Current Feedback
2	Channel 2 Current Feedback
3	LED Power Supply
4	LED Power Supply
5	Channel3 Current Feedback
6	Channel4 Current Feedback

6.0 SIGNAL TIMING SPECIFICATION

6.1 The DV220X2M-NV0 is operated by the DE only.

Item	Symbols		Min	Typ	Max	Unit	Note
DCLK	Period	tCLK	14.08	14.78	15.56	ns	
	Frequency	-	64.3	67.6	71	MHz	
Hsync	Period	tHP	550	550	550	tCLK	
	Horizontal Valid	tHV	480	480	480	tCLK	
	Horizontal Blank	tHB	70	70	70		
	Frequency	fH	121.1	123	124.7	KHz	
Vsync	Period	tVP	2049	2050	2051	tHP	
	Vertical Valid	tVV	1920	1920	1920	tHP	
	Vertical Blank	tVB	129	130	131	tHP	
	Frequency	fV	57	60	63	Hz	
LVDS Receiver clock	Input spread spectrum ratio	SSr	-	-	-	%	

6.2 LVDS Rx Interface Timing Parameter

The specification of the LVDS Rx interface timing parameter is shown in Table 4.

<Table 4. LVDS Rx Interface Timing Specification>

Item	Symbol	Min	Typ	Max	Unit	Remark
CLKIN Period	tRCIP	14.08	14.78	15.56	nsec	
Input Data 0	tRIP1	-0.4	0.0	+0.4	nsec	
Input Data 1	tRIP0	tRCIP/7-0.4	tRCIP/7	tRCIP/7+0.4	nsec	
Input Data 2	tRIP6	2 × tRCIP/7-0.4	2 × tRCIP/7	2 × tRCIP/7+0.4	nsec	
Input Data 3	tRIP5	3 × tRCIP/7-0.4	3 × tRCIP/7	3 × tRCIP/7+0.4	nsec	
Input Data 4	tRIP4	4 × tRCIP/7-0.4	4 × tRCIP/7	4 × tRCIP/7+0.4	nsec	
Input Data 5	tRIP3	5 × tRCIP/7-0.4	5 × tRCIP/7	5 × tRCIP/7+0.4	nsec	
Input Data 6	tRIP2	6 × tRCIP/7-0.4	6 × tRCIP/7	6 × tRCIP/7+0.4	nsec	

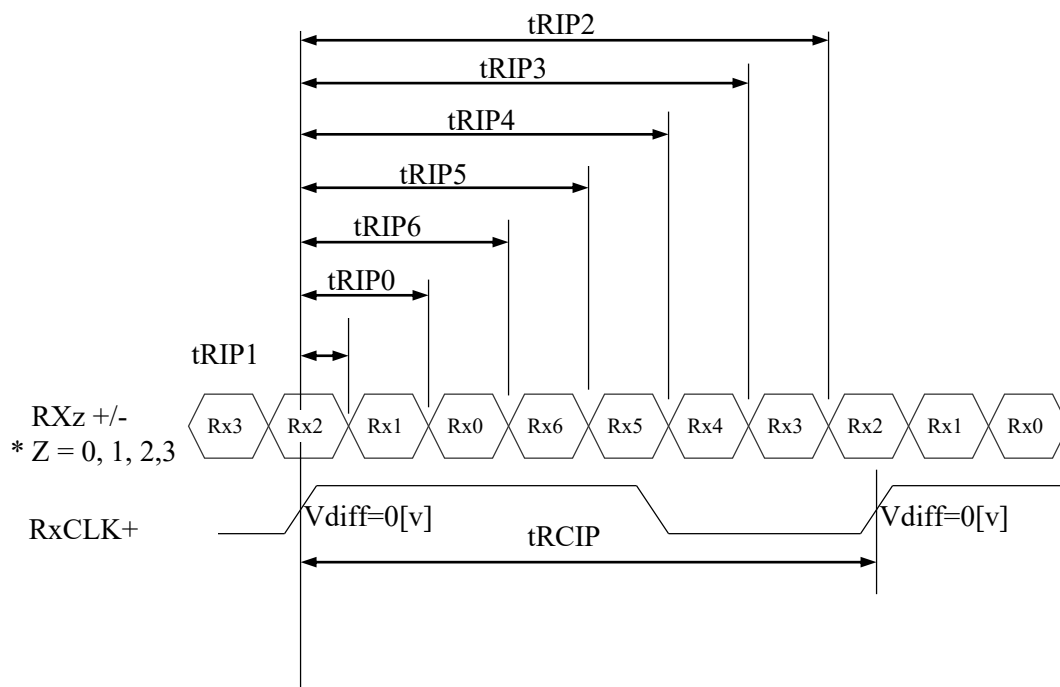

* Vdiff = (RXz+) - (RXz-), ..., (RXCLK+) - (RXCLK-)

7.0 SIGNAL TIMING WAVEFORMS OF INTERFACE SIGNAL

7.1 Sync Timing Waveforms

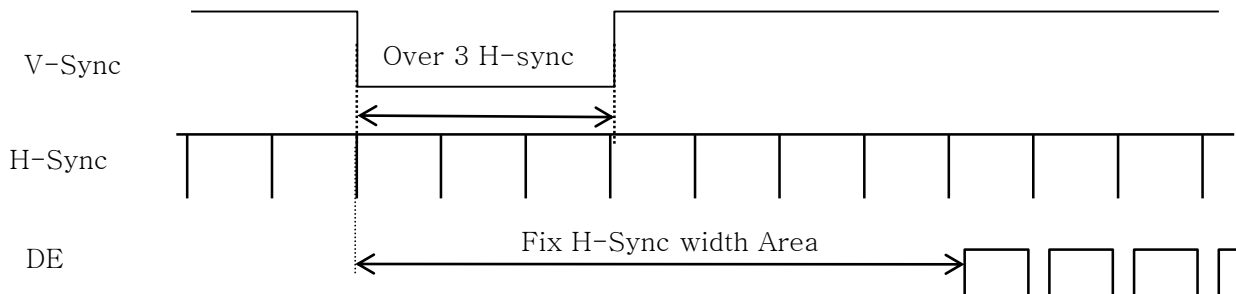

- 1) Need over 3 H-sync during V-Sync Low
- 2) Fix H-Sync width from V-Sync falling edge to first rising edge

7.2 Vertical Timing Waveforms

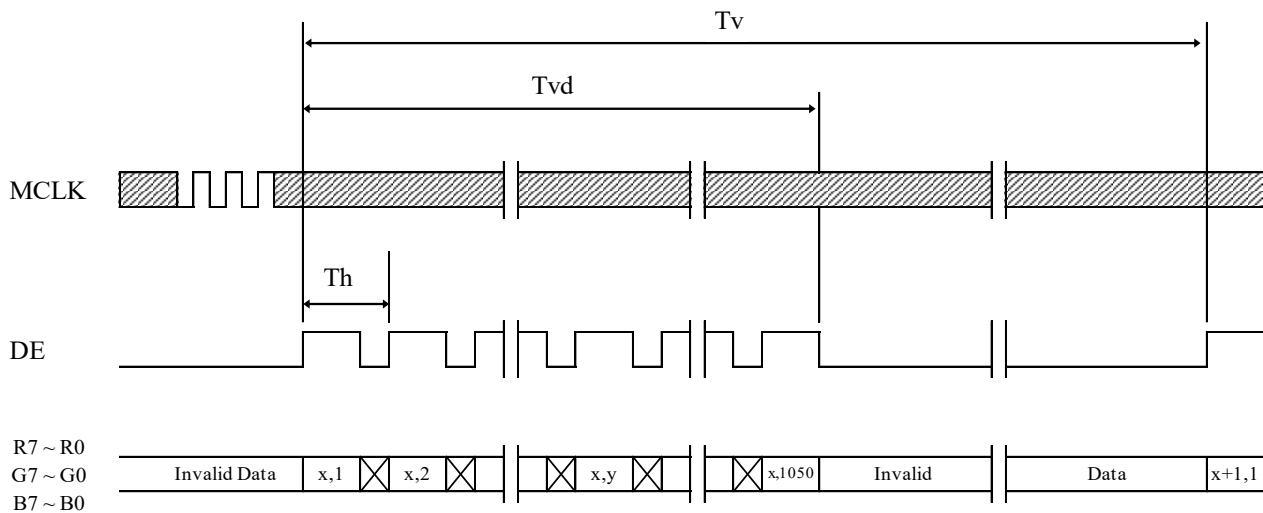

7.3 Horizontal Timing Waveforms

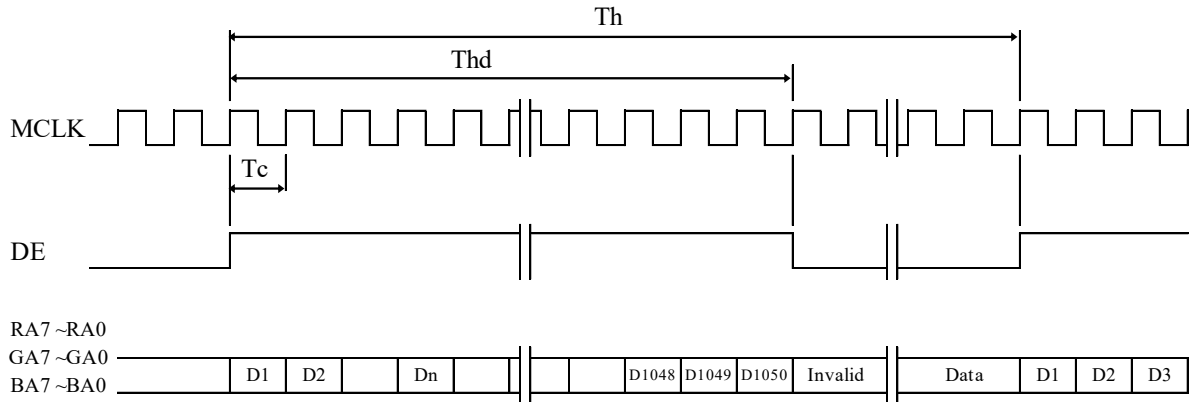

8.0 INPUT SIGNALS, BASIC DISPLAY COLORS & GRAY SCALE OF COLORS

Color & Gray Scale		RED DATA								GREEN DATA								BLUE DATA							
		R7	R6	R5	R4	R3	R2	R1	R0	G7	G6	G5	G4	G3	G2	G1	G0	B7	B6	B5	B4	B3	B2	B1	B0
Basic Colors	Black	0	0	0	0	0	0	0	0	0	0	0	0	0	0	0	0	0	0	0	0	0	0	0	0
	Blue	0	0	0	0	0	0	0	0	0	0	0	0	0	0	0	0	1	1	1	1	1	1	1	1
	Green	0	0	0	0	0	0	0	0	1	1	1	1	1	1	1	1	0	0	0	0	0	0	0	0
	Cyan	0	0	0	0	0	0	0	0	1	1	1	1	1	1	1	1	1	1	1	1	1	1	1	1
	Red	1	1	1	1	1	1	1	1	0	0	0	0	0	0	0	0	0	0	0	0	0	0	0	0
	Magenta	1	1	1	1	1	1	1	1	0	0	0	0	0	0	0	0	1	1	1	1	1	1	1	1
	Yellow	1	1	1	1	1	1	1	1	1	1	1	1	1	1	1	1	0	0	0	0	0	0	0	0
	White	1	1	1	1	1	1	1	1	1	1	1	1	1	1	1	1	1	1	1	1	1	1	1	1
Gray Scale of RED	Black	0	0	0	0	0	0	0	0	0	0	0	0	0	0	0	0	0	0	0	0	0	0	0	
	△	0	0	0	0	0	0	1	0	0	0	0	0	0	0	0	0	0	0	0	0	0	0	0	
	Darker	0	0	0	0	0	1	0	0	0	0	0	0	0	0	0	0	0	0	0	0	0	0	0	
	△	↑								↓								↑							
	▽	↓								↑								↓							
	Brighter	1	1	1	1	1	1	0	1	0	0	0	0	0	0	0	0	0	0	0	0	0	0	0	0
	▽	1	1	1	1	1	1	1	0	0	0	0	0	0	0	0	0	0	0	0	0	0	0	0	0
	Red	1	1	1	1	1	1	1	1	0	0	0	0	0	0	0	0	0	0	0	0	0	0	0	0
Gray Scale of GREEN	Black	0	0	0	0	0	0	0	0	0	0	0	0	0	0	0	0	0	0	0	0	0	0	0	
	△	0	0	0	0	0	0	0	0	0	0	0	0	0	0	1	0	0	0	0	0	0	0	0	
	Darker	0	0	0	0	0	0	0	0	0	0	0	0	0	1	0	0	0	0	0	0	0	0	0	
	△	↑								↓								↑							
	▽	↓								↑								↓							
	Brighter	0	0	0	0	0	0	0	0	1	1	1	1	1	1	0	1	0	0	0	0	0	0	0	0
	▽	0	0	0	0	0	0	0	0	1	1	1	1	1	1	1	0	0	0	0	0	0	0	0	0
	Green	0	0	0	0	0	0	0	0	1	1	1	1	1	1	1	1	0	0	0	0	0	0	0	0
Gray Scale of BLUE	Black	0	0	0	0	0	0	0	0	0	0	0	0	0	0	0	0	0	0	0	0	0	0	0	
	△	0	0	0	0	0	0	0	0	0	0	0	0	0	0	0	0	0	0	0	0	0	0	1	
	Darker	0	0	0	0	0	0	0	0	0	0	0	0	0	0	0	0	0	0	0	0	0	1	0	
	△	↑								↓								↑							
	▽	↓								↑								↓							
	Brighter	0	0	0	0	0	0	0	0	0	0	0	0	0	0	0	0	1	1	1	1	1	1	0	1
	▽	0	0	0	0	0	0	0	0	0	0	0	0	0	0	0	0	1	1	1	1	1	1	1	0
	Blue	0	0	0	0	0	0	0	0	0	0	0	0	0	0	0	0	1	1	1	1	1	1	1	1
Gray Scale of WHITE	Black	0	0	0	0	0	0	0	0	0	0	0	0	0	0	0	0	0	0	0	0	0	0	0	
	△	0	0	0	0	0	0	1	0	0	0	0	0	0	0	1	0	0	0	0	0	0	0	1	
	Darker	0	0	0	0	0	1	0	0	0	0	0	0	0	1	0	0	0	0	0	0	0	1	0	
	△	↑								↓								↑							
	▽	↓								↑								↓							
	Brighter	1	1	1	1	1	1	0	1	1	1	1	1	1	1	0	1	1	1	1	1	1	1	0	1
	▽	1	1	1	1	1	1	1	0	1	1	1	1	1	1	1	0	1	1	1	1	1	1	1	0
	White	1	1	1	1	1	1	1	1	1	1	1	1	1	1	1	1	1	1	1	1	1	1	1	1

9.0 POWER SEQUENCE

To prevent a latch-up or DC operation of the LCD module, the power on sequence shall be as shown in below

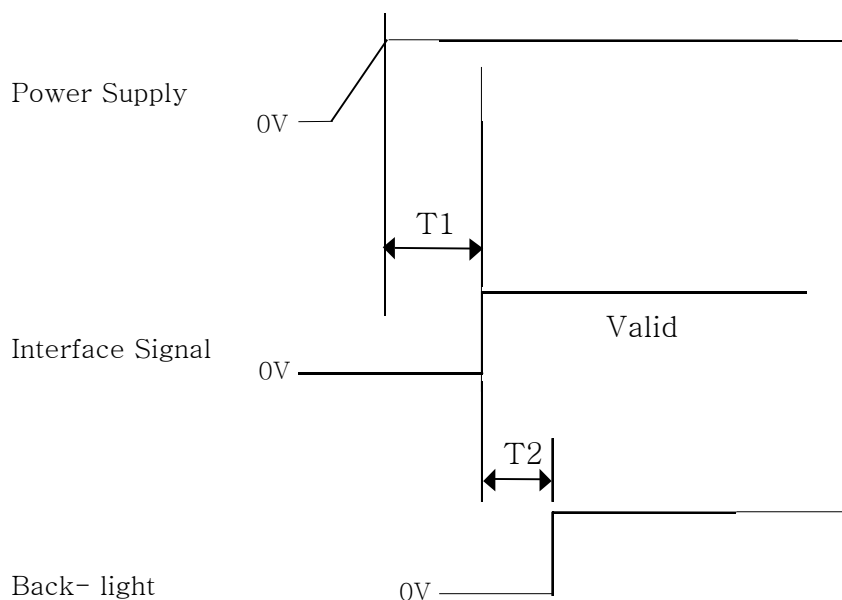

● $0 \leq T1 \leq 70 \text{ ms}$

● $200 \text{ ms} \leq T2$

Notes:

1. When the power supply VDD is 0V, keep the level of input signals on the low or keep high impedance.
2. Do not keep the interface signal high impedance when power is on.
3. Back Light must be turn on after power for logic and interface signal are valid.
4. The above power sequence should be satisfied at these case
 - .AC/DC power On/Off
 - .Mode Change (Resolution, frequency, timing, sleep mode, color depth change etc.)

If not to follow power sequence, there is a risk of abnormal display.

10.0 MECHANICAL CHARACTERISTICS

10.1 Dimensional Requirements

FIGURE 5 (located in Appendix) shows mechanical outlines for the model DV220X2M-NV0. Other parameters are shown in Table 8.

<Table 8. Dimensional Parameters>

Parameter	Specification	Unit
Dimensional outline	409.56(H) × 409.56(V) × 7.6(D) typ.	mm
Weight	1.96 ± 0.1	Kg
Active area	394.56(H) × 394.56(V)	mm
Pixel pitch	0.0685(H) x 0.2055(V)	mm
Number of pixels	1920(H) × 1920(V) (1 pixel = R + G + B dots)	pixels
Back-light	Right side 1-LED Light bar Type	

10.2 Mounting

See FIGURE 5 . (shown in Appendix)

10.3 Anti-Glare and Polarizer Hardness.

The surface of the LCD has an anti-glare coating to minimize reflection and a coating to reduce scratching.

10.4 Light Leakage

There shall not be visible light from the back-lighting system around the edges of the screen as seen from a distance 50cm from the screen with an overhead light level of 350lux.

11.0 RELIABILITY TEST

The Reliability test items and its conditions are shown in below.

<Table 9 Reliability Test Parameters >

No	Test Items	Conditions
1	High temperature storage test	Ta = 60 °C, 240 hrs
2	Low temperature storage test	Ta = -20 °C, 240 hrs
3	High temperature & high humidity operation test	Ta = 50 °C, 80%RH, 240hrs
4	High temperature operation test	Ta = 50 °C, 240hrs
5	Low temperature operation test	Ta = -5 °C, 240hrs
6	Thermal shock	Ta = -20 °C ↔ 60 °C (0.5 hr), 100 cycle
7	Electro-static discharge test	Air : 150 pF, 330Ω, 15 KV Contact : 150 pF, 330Ω, 8 KV
8	Altitude test	Non Operating: 40000 ft, -10°C / 24 Hr, 25°C / 24 Hr, -10°C / 24 Hr
		Operating: 15000 ft, 0°C / 24 Hr, 25°C / 24 Hr, 50°C / 24 Hr

12.0 HANDLING & CAUTIONS

(1) Cautions when taking out the module

- Pick the pouch only, when taking out module from a shipping package.

(2) Cautions for handling the module

- As the electrostatic discharges may break the LCD module, handle the LCD module with care. Peel a protection sheet off from the LCD panel surface as slowly as possible.
- As the LCD panel and back - light element are made from fragile glass material, impulse and pressure to the LCD module should be avoided.
- As the surface of the polarizer is very soft and easily scratched, use a soft dry cloth without chemicals for cleaning.
- Do not pull the interface connector in or out while the LCD module is operating.
- Put the module display side down on a flat horizontal plane.
- Handle connectors and cables with care.

(3) Cautions for the operation

- When the module is operating, do not lose CLK, ENAB signals. If any one of these signals is lost, the LCD panel would be damaged.
- Obey the supply voltage sequence. If wrong sequence is applied, the module would be damaged.

(4) Cautions for the atmosphere

- Dew drop atmosphere should be avoided.
- Do not store and/or operate the LCD module in a high temperature and/or humidity atmosphere. Storage in an electro-conductive polymer packing pouch and under relatively low temperature atmosphere is recommended.

(5) Cautions for the module characteristics

- Do not apply fixed pattern data signal to the LCD module at product aging.
- Applying fixed pattern for a long time may cause image sticking.

(6) Other cautions

- Do not disassemble and/or re-assemble LCD module.
- Do not re-adjust variable resistor or switch etc.
- When returning the module for repair or etc., Please pack the module not to be broken. We recommend to use the original shipping packages.

13.0 PRODUCT SERIAL NUMBER

DP/N XXXXXX	DV220X2M-NV0	B4	
XXXX	XXXXXXXXXXXXXXXXXXXX	REV XXX	
			
XX-XXXXXX-XXXXX-XXX-XXXX			MADE IN CHINA

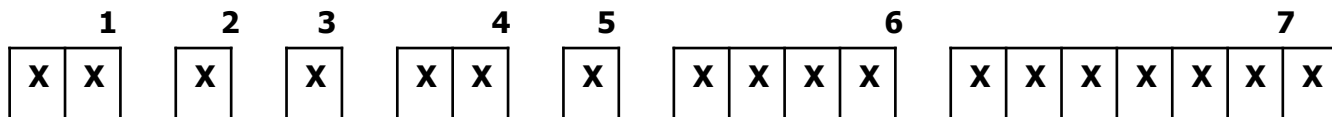

1. Control Number

2. Rank / Grade

3. Line Classification

4. Year (2001 : 01, 2002 : 02, ...)

5. Month (1,2,3, ... , 9, X, Y, Z)

6. Internal Use

7. Serial Number

14.0 Packing

14.1 Packing Order

-Put 1Pcs EPO Bottom into the box

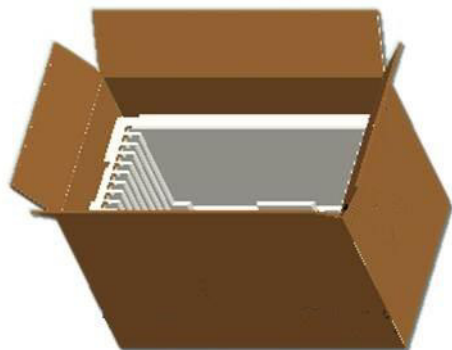

-Put each module into a PE bag
-Put 10Pcs MDL into the box

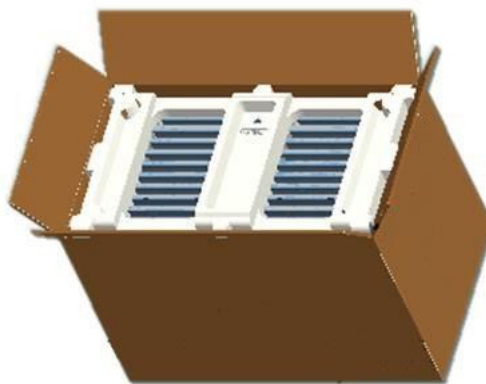
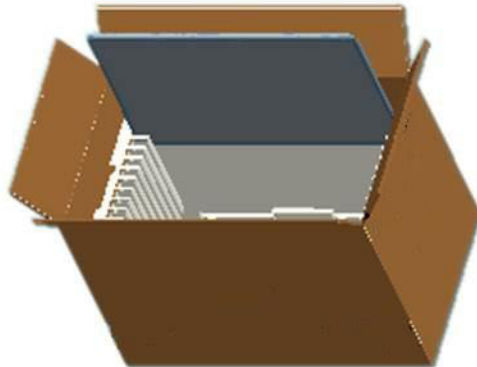

-Put 1 Pcs EPO cover in and seal the box.

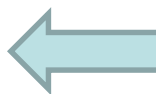

-Put the boxes on the Pallet, 24 boxes/Pallet: 8 boxes per layer, total 3 layers.
-Place paper corners and wrap film around the boxes
-Pack with 4 packing belts

14.3 Packing Specification and Note

Item	Specification			Remark
	Q'ty	Dimension(mm)	Weight (kg)	
Panel	240	409.6(H) × 409.6(V) × 12(D) typ.	2.4	-
Box	24	481(L)×304(W)×493(H)	0.588	10pcs/Box
Inner Box	24	495(L)×318(W)×495(H)	1.3	AB型瓦楞纸箱
PE Bag	240	460(L)×460(W)×0.05(H)	-	
Pallet	1	1280(L)×1000(W)×130(H))	18	24Box/Pallet 3层/Pallet

14.3 Box label

- Label Size : 108 mm (L) × 56 mm (W)
- Contents
 Model : DV220X2M-NV0
 Q`ty : Module10 Q`ty in one box
 Serial No. : Box Serial No.
 Date : Packing Date
 FG Code : FG Code of Product

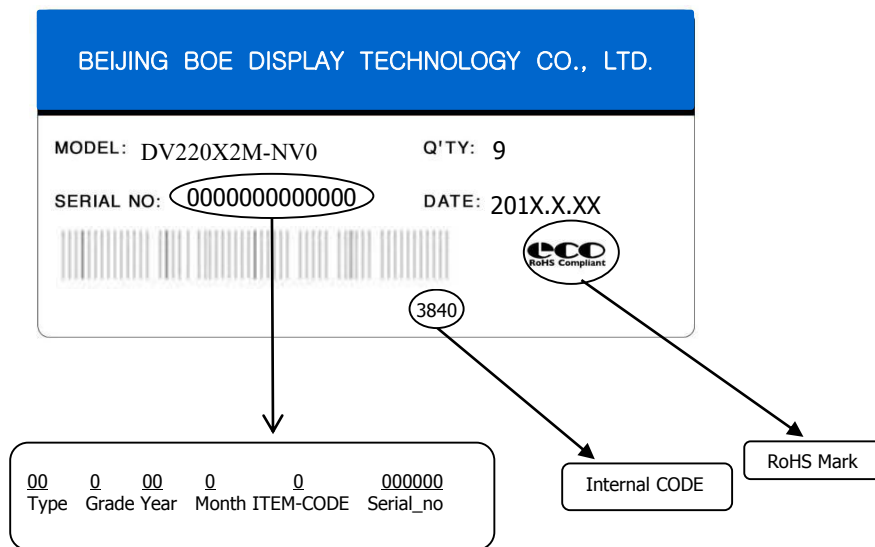

15.0 APPENDIX

Figure 1. Measurement Set Up

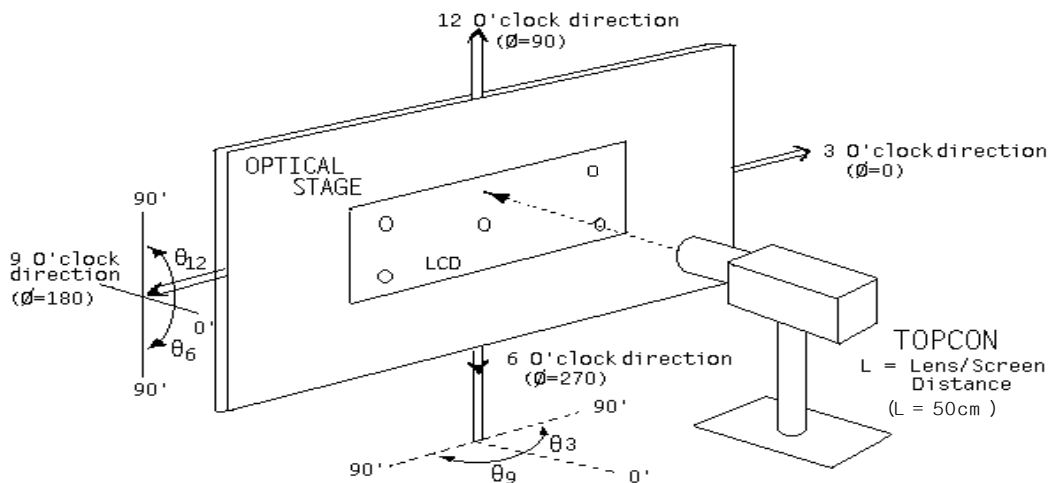

Figure 2. White Luminance and Uniformity Measurement Locations (9 points)

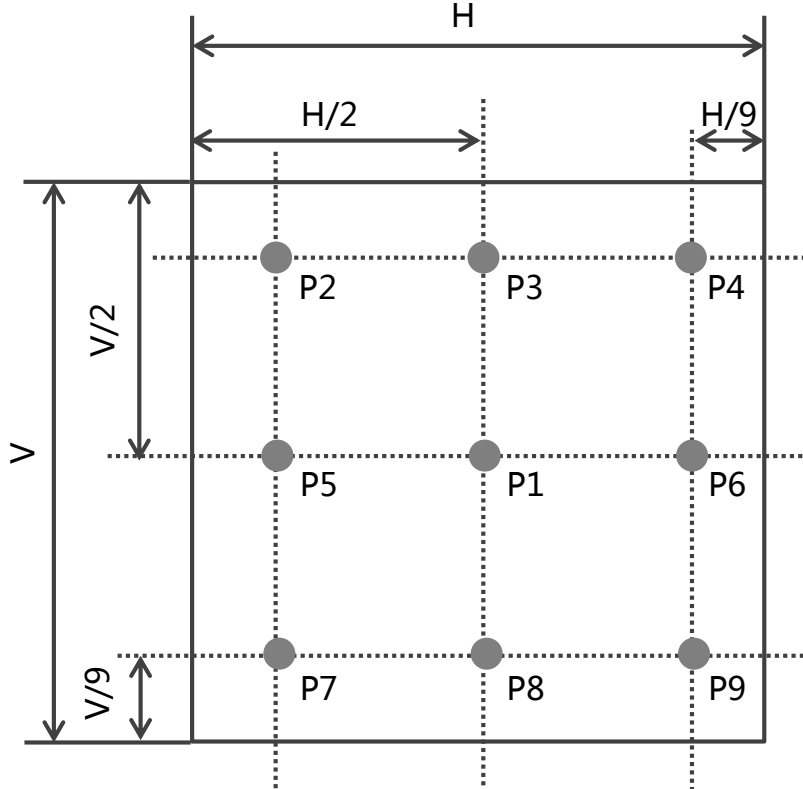
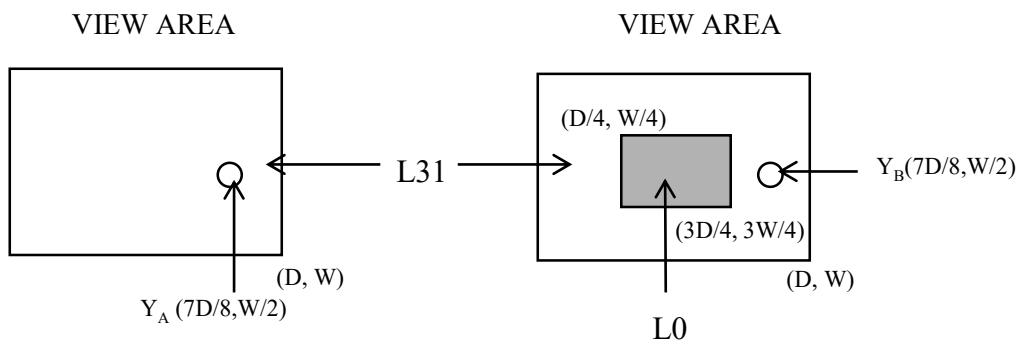

Figure 3. Response Time Testing



Figure 4. Cross Modulation Test Description



$$\text{Cross-Talk (\%)} = \left| \frac{Y_B - Y_A}{Y_A} \right| \times 100$$

Where: Y_A = Initial luminance of measured area (cd/m²)
 Y_B = Subsequent luminance of measured area (cd/m²)
 The location measured will be exactly the same in both patterns

Figure 5. TFT-LCD Module Outline Dimensions (Front view)

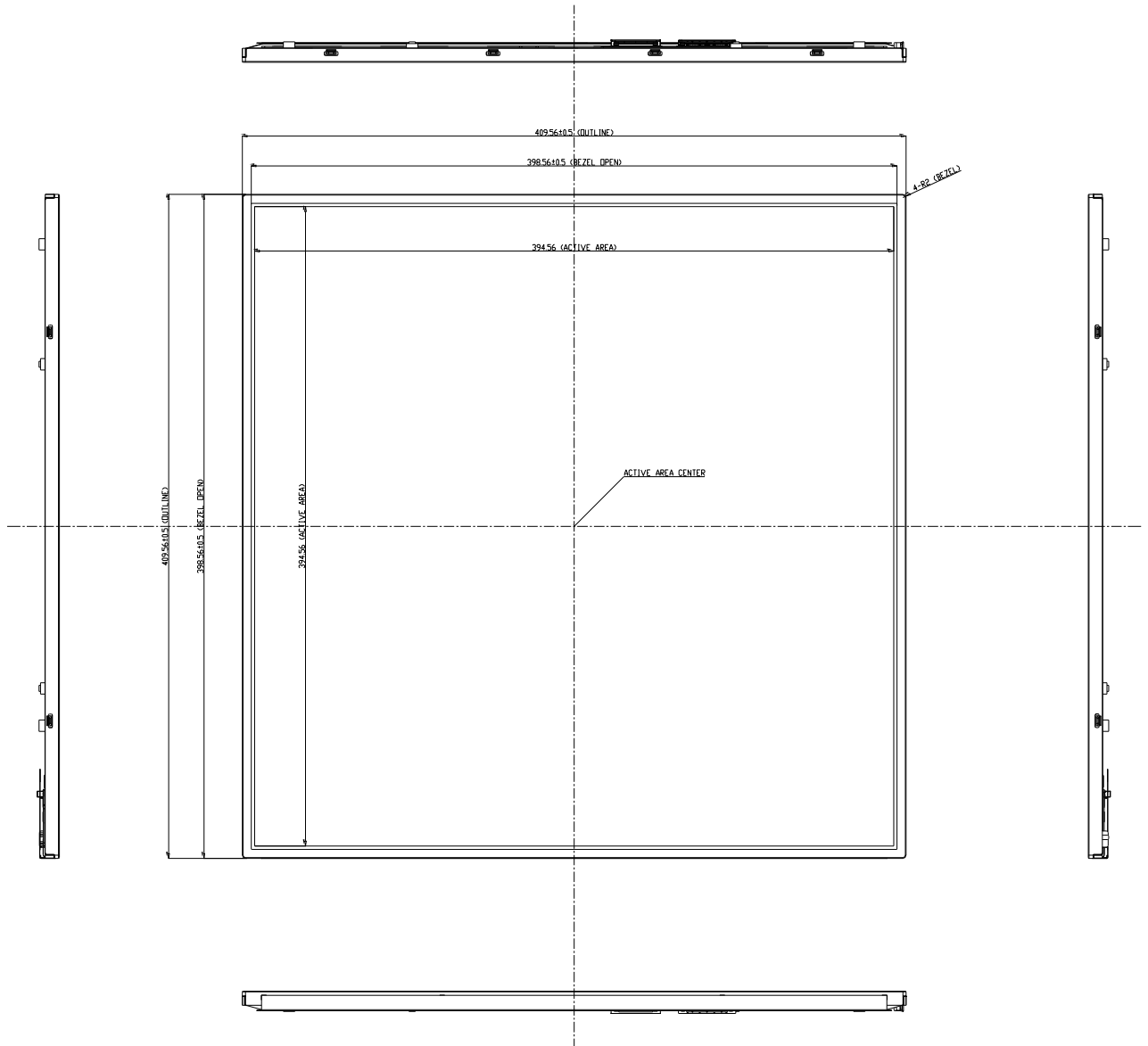
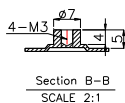
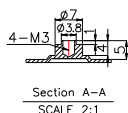
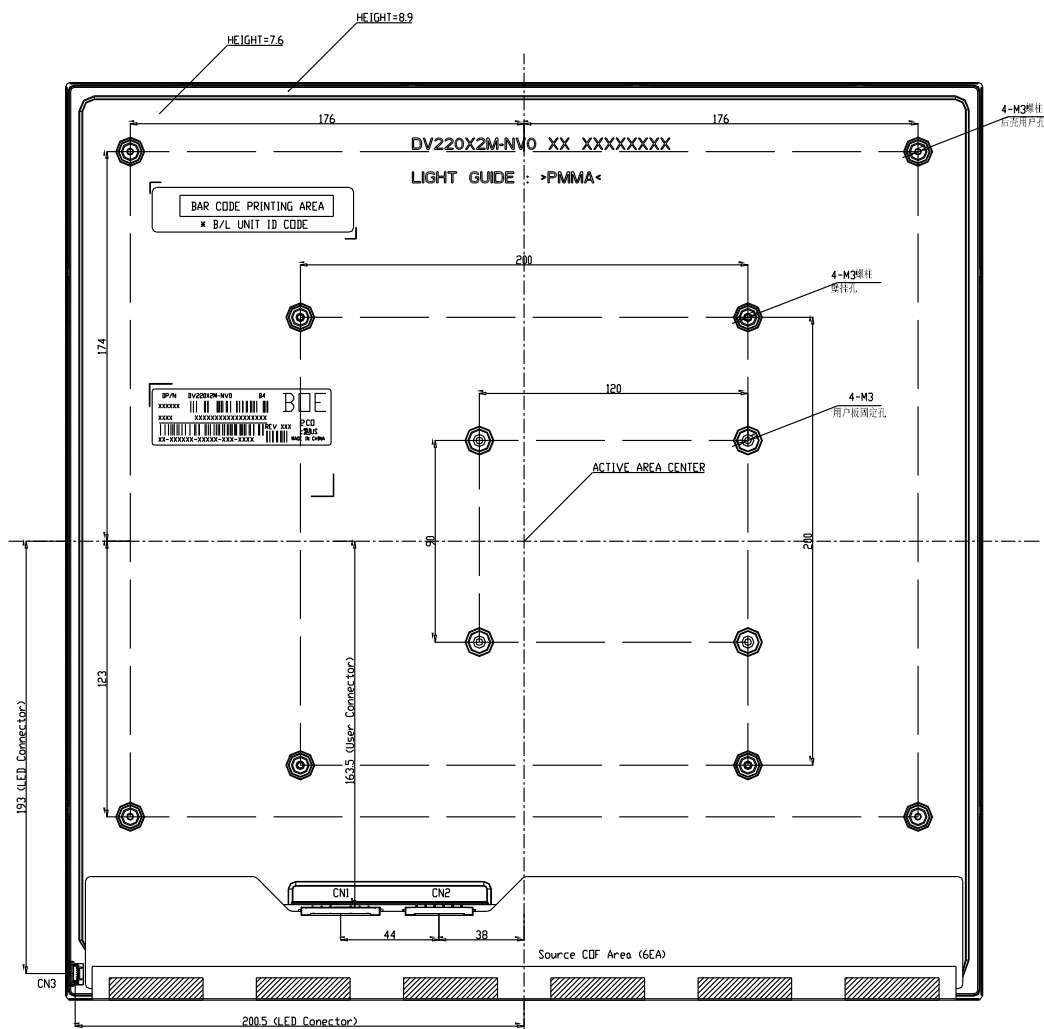
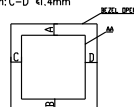

Figure 6. TFT-LCD Module Outline Dimensions (Rear view)



Notes:

1. CN1: 51pin (Lvds+5V Input interface)
- CN2: 41Pin (Lvds Input interface)
- CN3: 6Pin (3707K-006N-08X)
2. The COF area is weak and sensitive, so please don't press the COF area
3. Tilt and partial disposition tolerance of display area as following
 - (1) Y-direction: A-B $\leq 1.4\text{mm}$
 - (2) X-direction: C-D $\leq 1.4\text{mm}$





ALL TECHNOLOGIES. ALL COMPETENCIES. ONE SPECIALIST.

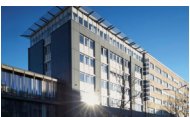

DATA MODUL AG
Landsberger Straße 322 DE-
80687 Munich
Phone: +49-89-56017-0

DATA MODUL WEIKERSHEIM GMBH
Lindenstraße 8
DE-97990 Weikersheim Phone:
+49-7934-101-0



More information and worldwide locations can be found at

www.data-modul.com