



SPECIFICATION

BOE

DV280FBM-NB1

28,0" TFT - FHD - LVDS

Version: 1.0

Date: 21.01.2016

Note: This specification is subject to change without prior notice

TITLE:**DV280FBM-NB1
Product Specification****Rev. P0**

Approved by	张周生
Date	2016.1.21

HEFEI BOE OPTOELECTRONICS TECHNOLOGY

Contents

No	ITEM	Page
	REVISIONS HISTORY	2
	CONTENTS	3
1	GENERAL DESCRIPTION	4
	1.1 Introduction	
	1.2 Features	
	1.3 Applications	
	1.4 General Specification	
2	ABSOLUTE MAXIMUM RATINGS	6
3	ELECTRICAL SPECIFICATIONS	7
4	INTERFACE CONNECTION	9
	4.1 Open Cell Input Signal & Power	
	4.2 LVDS Interface	
5	SIGNAL TIMING SPECIFICATIONS	13
	5.1 Timing Parameters	
	5.2 Signal Timing Waveform	
	5.3 Input Signals, Basic Display Colors & Cray Scale Of Colors	
	5.4 Power Sequence	
6	OPTICAL SPECIFICATIONS	17
7	MECHANICAL CHARACTERISTICS	19
8	RELIABILITY	20
9	PRODUCT SERIAL NUMBER	21
10	PACKING INFORMATION	22
11	HANDLING & CAUTIONS	24
12	APPENDIX	25

BOE	PRODUCT GROUP	REV	ISSUE DATE
	TFT LCD	P0	2016.1.21

1.0 GENERAL DESCRIPTION

1.1 Introduction

DV280FBM-NB1 is a color active matrix TFT LCD Module using amorphous silicon TFT's (Thin Film Transistors) as an active switching devices. This Module has a 28inch diagonally measured active area with FHD resolutions (1920 horizontal by 360 vertical pixel array). Each pixel is divided into RED, GREEN, BLUE dots which are arranged in vertical stripe and this module can display 16.7M colors. The TFT-LCD panel used for this Module is adapted for a low reflection and higher color type.

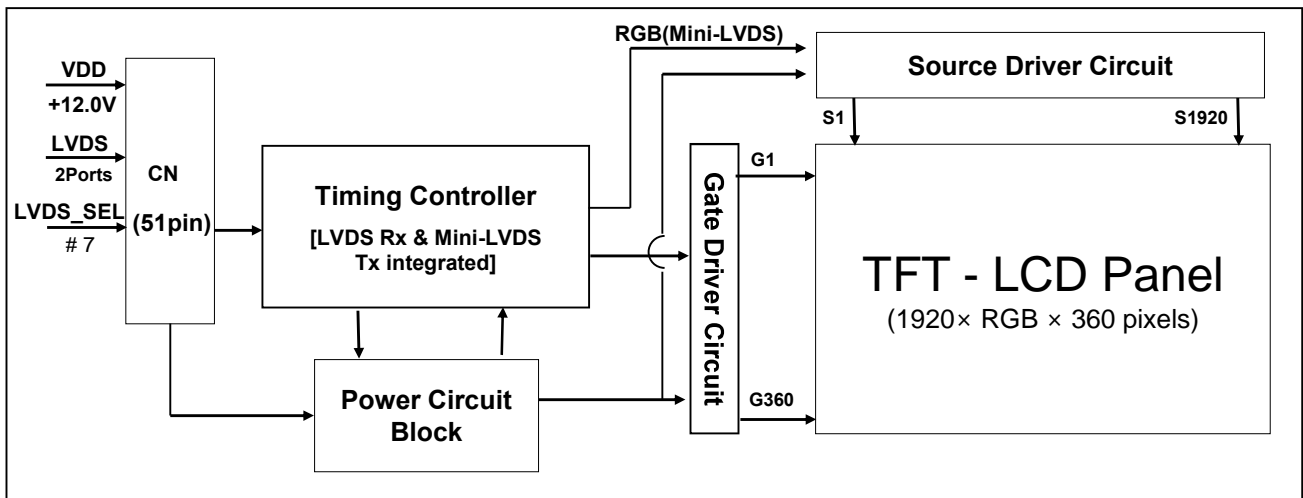

1.2 Features

- Cutting efficiency 90.5%, panel transmittance 6%;
- 4 shot normal design, High Response Time 8ms
- Matrix Vcom design(1/3);
- Lightweight design, Body 8.9mm , Depth 16.8mm
- Array process : 1+4mask, AT : 2G3D, Q-CT: 2G3D(S/B detection)
- RoHS compliant

SPEC. NUMBER	SPEC. TITLE DV280FBM-NB1 Product Specification	PAGE 4 of 29
--------------	---	-----------------

BOE	PRODUCT GROUP	REV	ISSUE DATE
	TFT LCD	P0	2016.1.21

1.3 Application

- TFT-LCD Display for transportation system and financial system
- Display Terminals for diversified information

1.4 General Specification

< Table 1. General Specifications >

Parameter	Specification	Unit	Remarks
Active Area	699.84(H)*131.22(V)	mm	
Number Of Pixels	1920(H)×360(V)	pixels	
Pixel Pitch	121.5×364.5	um	
Pixel Arrangement	Pixels RGB stripe arrangement		
Display Colors	16.7M(8bits)	colors	
Display Mode	ADS		
Brightness	700	nit	
MDL Outline	732(H)x165(V)	mm	
MDL Thickness	16.8	mm	
Power Consumption	24.8 (Logic : 4.2、 BLU : 20.6)	watt	

SPEC. NUMBER	SPEC. TITLE DV280FBM-NB1 Product Specification	PAGE 5 of 29
--------------	---	-----------------

2.0 ABSOLUTE MAXIMUM RATINGS

The followings are maximum values which, if exceed, may cause faulty operation or damage to the unit. The operational and non-operational maximum voltage and current values are listed in Table 2.

< Table 2. LCD Open Cell Electrical Specifications >

[VSS=GND=0V]

Parameter	Symbol	Min.	Max.	Unit	Remark
Power Supply Voltage	VDD	VSS-0.3	13.2	V	Ta = 25 °C
Operating Temperature	T _{OP}	0	+50	°C	Note 1
	T _{SUR}	0	+60	°C	
Storage Temperature	T _{ST}	-20	+60	°C	
Operating Ambient Humidity	Hop	10	80	%RH	
Storage Humidity	Hst	10	80	%RH	

Note 1 : Temperature and relative humidity range are shown in the figure below.
Wet bulb temperature should be 39 °C max. and no condensation of water.

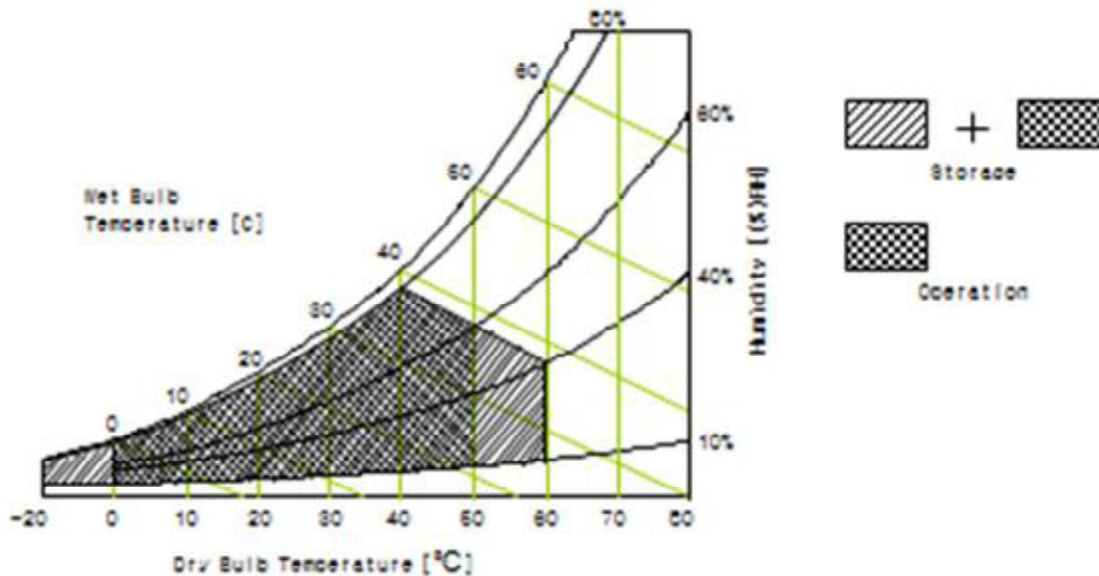

3.0 ELECTRICAL SPECIFICATIONS

3.1 Electrical Specifications

< Table 3. LCD Open Cell Electrical Specifications >

[Ta =25±2 °C]

Parameter		Symbol	Values			Unit	Remark
			Min	Typ	Max		
Power Supply Input Voltage		VDD	10.8	12	13.2	V	
Power Supply Ripple Voltage		VRP			500	mV	
Power Supply Current		IDD	-	290	360	mA	Note 1
Power Consumption		PDD		3.48	4.4	W	
LVDS Interface	Differential Input High Threshold Voltage	VRTH	+100		+360	mV	
	Differential Input Low Threshold Voltage	VRTL	-360		-100	mV	
	Common Input Voltage	VLVC	1.0	1.2	1.4	V	
CMOS Interface	Input High Threshold Voltage	VIH	2.7	-	3.3	V	
	Input Low Threshold Voltage	VIL	0	-	0.6	V	

Note 1 : The supply voltage is measured and specified at the interface connector of LCM.

The current draw and power consumption specified is for VDD=12.0V,

Frame rate $f_v=60\text{Hz}$ and Clock frequency = 75.4MHz.

Test Pattern of power supply current

a) Typ : Mosaic 8 x 8 Pattern*)

b) Max : Vertical Line Sub Line255

(Only display 1/3) (L0/L255)

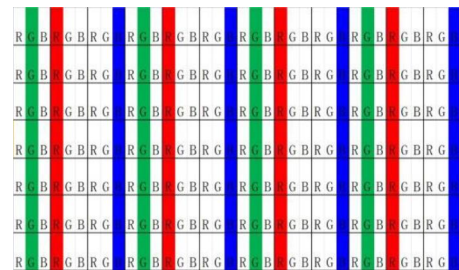
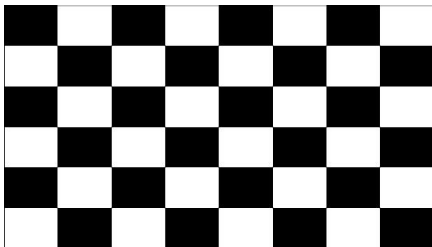

3.2 Backlight Unit

< Table 4. Backlight Input Pin Assignments >

Pin No.	Symbol	Feature
1	CH1+	VLED OUT CH1
2	CH1-	I Return CH1
3	NC	NC
4	NC	NC
5	CH2+	VLED OUT CH2
6	CH2-	I Return CH2

< Table 5. DC Input Specification >

[Ta =25±2 °C]

Parameter		Min.	Typ.	Max.	Unit
LED Forward Voltage	VF	40.6	43.4	44.8	V
LED Forward Current	IF		208	240	mA
LED Power Consumption	PLED		18		W
LED Life-Time	N/A		50000		Hour

Notes : The LED Life-time define as the estimated time to 50% degradation of initial luminous.

4.0 INTERFACE CONNECTION**4.1 Module Input Signal & Power**

- Connector : S050-C51B-C39-S or Equivalent.

< Table 4. Open Cell Input Connector Pin Configuration >

Pin No	Symbol	Description	Pin No	Symbol	Description
1	N.C.	No Connection	24	N.C.	No Connection
2	SDA	SDA	25	N.C.	No Connection
3	SCL	SCL	26	GND	Ground
4	WP	Write Production	27	GND	Ground
5	N.C.	No Connection	28	CH2_0-	LVDS Channel 2,Signal0-
6	N.C.	No Connection	29	CH2_0+	LVDS Channel 2,Signal0+
7	LVDS_SEL	'H'=JEIDA , 'L'or NC= VESA	30	CH2_1-	LVDS Channel 2,Signal1-
8	N.C.	No Connection	31	CH2_1+	LVDS Channel 2,Signal1+
9	N.C.	No Connection	32	CH2_2-	LVDS Channel 2,Signal2-
10	GND	Ground	33	CH2_2+	LVDS Channel 2,Signal2+
11	GND	Ground	34	GND	Ground
12	CH1_0-	LVDS Channel 1,Signal0-	35	CH2_CLK-	LVDS Channel 2,Clock-
13	CH1_0+	LVDS Channel 1,Signal0+	36	CH2_CLK+	LVDS Channel 2, Clock+
14	CH1_1-	LVDS Channel 1,Signal1-	37	GND	Ground
15	CH1_1+	LVDS Channel 1,Signal1+	38	CH2_3-	LVDS Channel 2,Signal3-
16	CH1_2-	LVDS Channel 1,Signal2-	39	CH2_3+	LVDS Channel 2,Signal3+
17	CH1_2+	LVDS Channel 1,Signal2+	40	N.C.	No Connection
18	GND	Ground	41	N.C.	No Connection
19	CH1_CLK-	LVDS Channel 1,Clock-	42	GND	Ground
20	CH1_CLK+	LVDS Channel 1, Clock+	43	GND	Ground
21	GND	Ground	44	GND	Ground
22	CH1_3-	LVDS Channel 1,Signal3-	45	GND	Ground
23	CH1_3+	LVDS Channel 1,Signal3+	46	GND	Ground

BOE	PRODUCT GROUP	REV	ISSUE DATE
	TFT LCD	P0	2016.1.21

4.0 INTERFACE CONNECTION

Pin No	Symbol	Description	Pin No	Symbol	Description
47	N.C.	No Connection	50	VDD	Power Supply +12.0V
48	VDD	Power Supply +12.0V	51	VDD	Power Supply +12.0V
49	VDD	Power Supply +12.0V			

- Notes :
1. NC(Not Connected) : This pins are only used for BOE internal operations.
 2. Input Level of LVDS signal is based on the EIA-644 Standard.
 3. LVDS_SEL : This pin is used for selecting LVDS signal data format.
 If this Pin : High (3.3V) → JEIDA LVDS format
 Otherwise : Low (GND) or Open (NC) → Normal NS LVDS format

Rear view of LCM

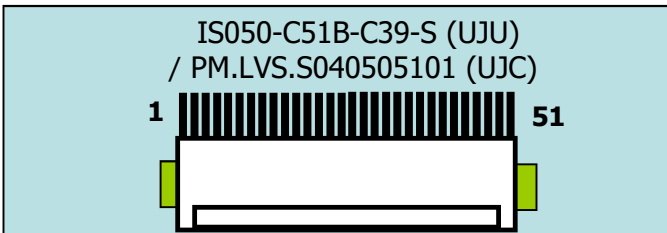

BIST Pattern

PT1: Black (2 sec)	PT1: White (2 sec)	PT1: Red (2 sec)	PT1: Green (2 sec)	PT1: Blue (2 sec)

Flicker Pattern

+	-	+	-	+	-	+	-	+	-
+	-	+	-	+	-	+	-	+	-
-	+	-	+	-	+	-	+	-	+
+	-	+	-	+	-	+	-	+	-
-	+	-	+	-	+	-	+	-	+

SPEC. NUMBER	SPEC. TITLE DV280FBM-NB1 Product Specification	PAGE 10 of 29
--------------	---	------------------

4.2 LVDS Interface

- LVDS Receiver : Timing Controller (LVDS Rx merged) / LVDS Data : Pixel Data

< Table 5. Open Cell Input Connector Pin Configuration >

	LVDS Pin	Vesa Data format	JEIDA Data format	Remark
TxOUT/RxIN0	TxIN/RxOUT0	Red0 [LSB]	R2	
	TxIN/RxOUT1	Red1	R3	
	TxIN/RxOUT2	Red2	R4	
	TxIN/RxOUT3	Red3	R5	
	TxIN/RxOUT4	Red4	R6	
	TxIN/RxOUT6	Red5	R7 [MSB]	
	TxIN/RxOUT7	Green0 [LSB]	G2	
TxOUT/RxIN1	TxIN/RxOUT8	Green1	G3	
	TxIN/RxOUT9	Green2	G4	
	TxIN/RxOUT12	Green3	G5	
	TxIN/RxOUT13	Green4	G6	
	TxIN/RxOUT14	Green5	G7 [MSB]	
	TxIN/RxOUT15	Blue0 [LSB]	B2	
	TxIN/RxOUT18	Blue1	B3	
TxOUT/RxIN2	TxIN/RxOUT19	Blue2	B4	
	TxIN/RxOUT20	Blue3	B5	
	TxIN/RxOUT21	Blue4	B6	
	TxIN/RxOUT22	Blue5	B7 [MSB]	
	TxIN/RxOUT24	HSYNC	HSYNC	
	TxIN/RxOUT25	VSYNC	VSYNC	
	TxIN/RxOUT26	DEN	DEN	
TxOUT/RxIN3	TxIN/RxOUT27	Red6	R0 [LSB]	
	TxIN/RxOUT5	Red7 [MSB]	R1	
	TxIN/RxOUT10	Green6	G0 [LSB]	
	TxIN/RxOUT11	Green7 [MSB]	G1	
	TxIN/RxOUT16	Blue6	B0 [LSB]	
	TxIN/RxOUT17	Blue7 [MSB]	B1	
	TxIN/RxOUT23	Reserved	Reserved	

4.3 LVDS Rx Interface Timing Parameter

The specification of the LVDS Rx interface timing parameter is shown in Table 6.

<Table 6. LVDS Rx Interface Timing Specification>

Item	Symbol	Min	Typ	Max	Unit	Remark
CLKIN Period	tRCIP	10.20	13.47	17.08	nsec	
Input Data 0	tRIP1	-0.4	0.0	+0.4	nsec	
Input Data 1	tRIP0	tRCIP/7-0.4	tRCIP/7	tRCIP/7+0.4	nsec	
Input Data 2	tRIP6	2 × tRCIP/7-0.4	2 × tRCIP/7	2 × tRCIP/7+0.4	nsec	
Input Data 3	tRIP5	3 × tRCIP/7-0.4	3 × tRCIP/7	3 × tRCIP/7+0.4	nsec	
Input Data 4	tRIP4	4 × tRCIP/7-0.4	4 × tRCIP/7	4 × tRCIP/7+0.4	nsec	
Input Data 5	tRIP3	5 × tRCIP/7-0.4	5 × tRCIP/7	5 × tRCIP/7+0.4	nsec	
Input Data 6	tRIP2	6 × tRCIP/7-0.4	6 × tRCIP/7	6 × tRCIP/7+0.4	nsec	

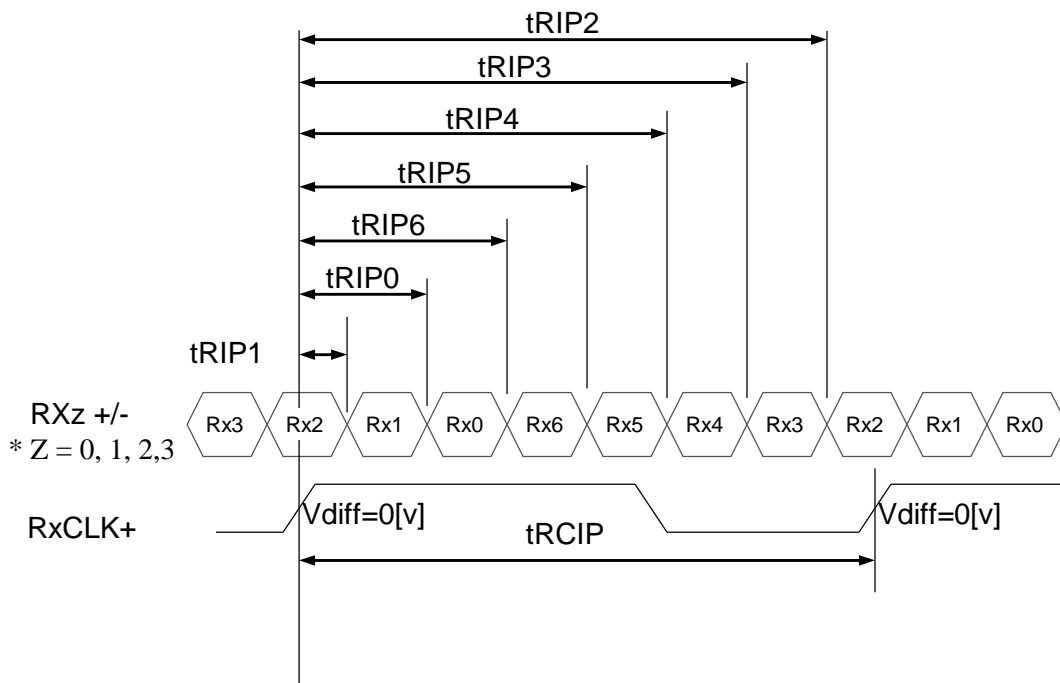

* $V_{diff} = (RXz+) - (RXz-), \dots, (RXCLK+) - (RXCLK-)$

5.0 SIGNAL TIMING SPECIFICATION

5.1 Timing Parameters (DE only mode)

< Table 7. Timing Table >

Item		Symbols	Min	Typ	Max	Unit	
Clock	Frequency	1/Tc	58	74.25	97	MHz	
	High Time	Tch	-	4/7Tc	-		
	Low Time	Tcl	-	4/7Tc	-		
Frame Period		Tv	1100	1125	1149	lines	
			47	60	78	Hz	
Horizontal Active Display Term		Valid	t _{HV}	-	960	-	t _{CLK}
		Total	t _{HP}	1060	1100	1200	t _{CLK}
Vertical Active Display Term		Valid	t _{VV}	-	1080	-	t _{HP}
		Total	t _{VP}	1100	1125	1149	t _{HP}

Notes: This product is DE only mode. The input of Hsync & Vsync signal does not have an effect on normal operation.

5.2 Signal Timing Waveform

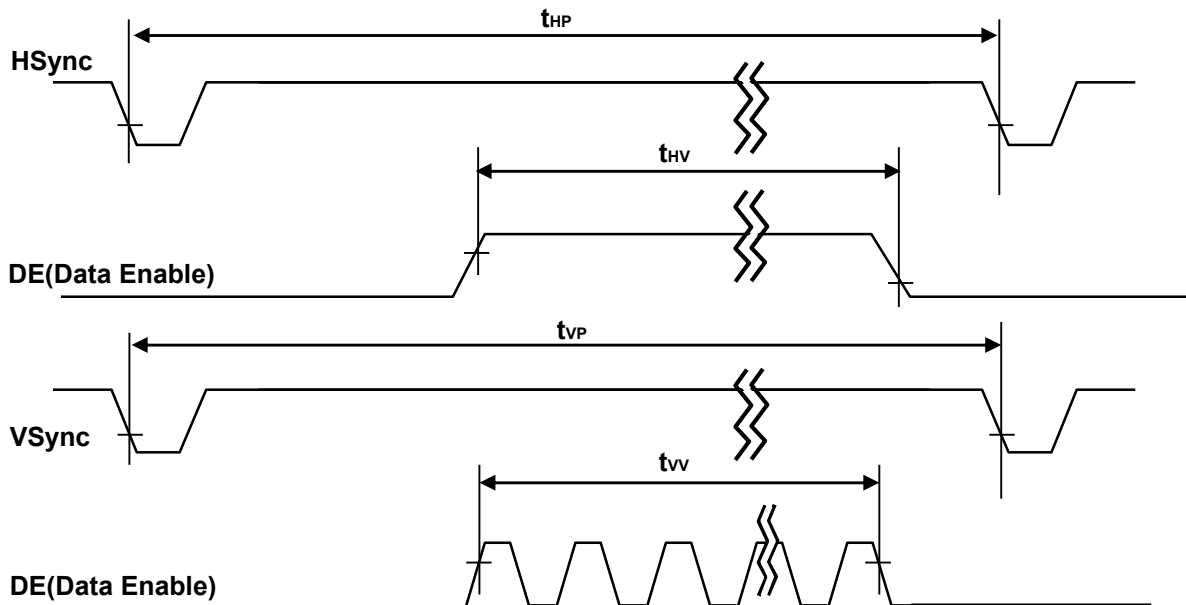
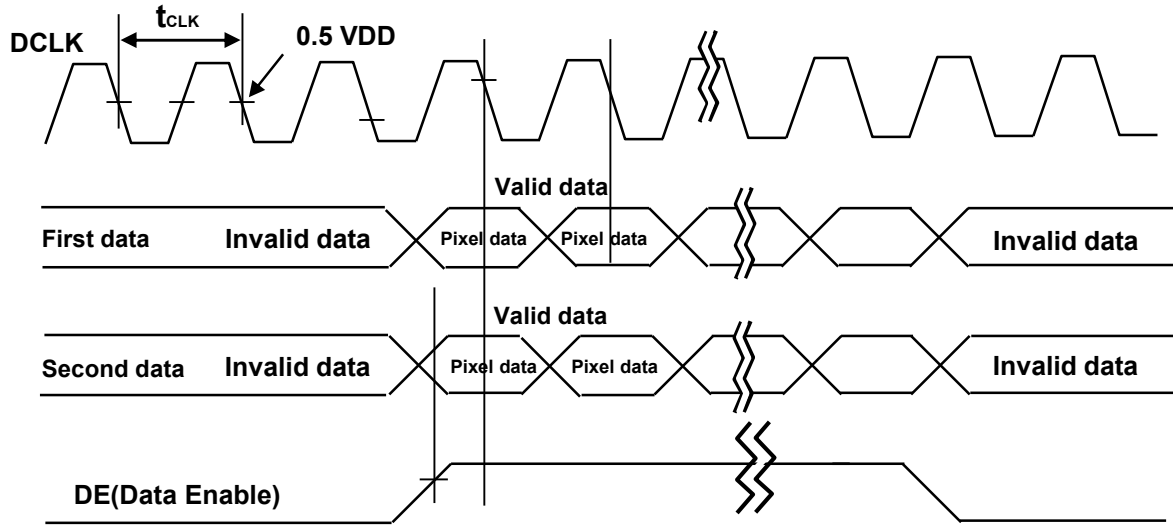

5.3 Input Signals, Basic Display Colors and Gray Scale of Colors

< Table 8. Input Signal and Display Color Table >

Color & Gray Scale		Input Data Signal																							
		Red Data								Green Data						Blue Data									
		R7	R6	R5	R4	R3	R2	R1	R0	G7	G6	G5	G4	G3	G2	G1	G0	B7	B6	B5	B4	B3	B2	B1	B0
Basic Colors	Black	0	0	0	0	0	0	0	0	0	0	0	0	0	0	0	0	0	0	0	0	0	0	0	0
	Blue	0	0	0	0	0	0	0	0	0	0	0	0	0	0	0	0	1	1	1	1	1	1	1	1
	Green	0	0	0	0	0	0	0	0	1	1	1	1	1	1	1	1	0	0	0	0	0	0	0	0
	Cyan	0	0	0	0	0	0	0	0	1	1	1	1	1	1	1	1	1	1	1	1	1	1	1	1
	Red	1	1	1	1	1	1	1	1	0	0	0	0	0	0	0	0	0	0	0	0	0	0	0	0
	Magenta	1	1	1	1	1	1	1	1	0	0	0	0	0	0	0	0	1	1	1	1	1	1	1	1
	Yellow	1	1	1	1	1	1	1	1	1	1	1	1	1	1	1	1	0	0	0	0	0	0	0	0
	White	1	1	1	1	1	1	1	1	1	1	1	1	1	1	1	1	1	1	1	1	1	1	1	1
Gray Scale of Red	Black	0	0	0	0	0	0	0	0	0	0	0	0	0	0	0	0	0	0	0	0	0	0	0	
	△	0	0	0	0	0	0	0	1	0	0	0	0	0	0	0	0	0	0	0	0	0	0	0	
	Darker	0	0	0	0	0	0	0	1	0	0	0	0	0	0	0	0	0	0	0	0	0	0	0	
	△	↑								↑						↑									
	▽	↓								↓						↓									
	Brighter	1	1	1	1	1	1	0	1	0	0	0	0	0	0	0	0	0	0	0	0	0	0	0	0
	▽	1	1	1	1	1	1	1	0	0	0	0	0	0	0	0	0	0	0	0	0	0	0	0	0
	Red	1	1	1	1	1	1	1	1	0	0	0	0	0	0	0	0	0	0	0	0	0	0	0	0
Gray Scale of Green	Black	0	0	0	0	0	0	0	0	0	0	0	0	0	0	0	0	0	0	0	0	0	0	0	
	△	0	0	0	0	0	0	0	0	0	0	0	0	0	0	0	1	0	0	0	0	0	0	0	
	Darker	0	0	0	0	0	0	0	0	0	0	0	0	0	0	1	0	0	0	0	0	0	0	0	
	△	↑								↑						↑									
	▽	↓								↓						↓									
	Brighter	0	0	0	0	0	0	0	0	1	1	1	1	1	1	0	1	0	0	0	0	0	0	0	0
	▽	0	0	0	0	0	0	0	0	1	1	1	1	1	1	0	0	0	0	0	0	0	0	0	0
	Green	0	0	0	0	0	0	0	0	1	1	1	1	1	1	1	1	0	0	0	0	0	0	0	0
Gray Scale of Blue	Black	0	0	0	0	0	0	0	0	0	0	0	0	0	0	0	0	0	0	0	0	0	0	0	
	△	0	0	0	0	0	0	0	0	0	0	0	0	0	0	0	0	0	0	0	0	0	0	1	
	Darker	0	0	0	0	0	0	0	0	0	0	0	0	0	0	0	0	0	0	0	0	0	0	1	
	△	↑								↑						↑									
	▽	↓								↓						↓									
	Brighter	0	0	0	0	0	0	0	0	0	0	0	0	0	0	0	0	1	1	1	1	1	1	0	1
	▽	0	0	0	0	0	0	0	0	0	0	0	0	0	0	0	0	1	1	1	1	1	1	1	0
	Blue	0	0	0	0	0	0	0	0	0	0	0	0	0	0	0	0	1	1	1	1	1	1	1	1
Gray Scale of White	Black	0	0	0	0	0	0	0	0	0	0	0	0	0	0	0	0	0	0	0	0	0	0	0	
	△	0	0	0	0	0	0	0	1	0	0	0	0	0	0	0	1	0	0	0	0	0	0	1	
	Darker	0	0	0	0	0	0	1	0	0	0	0	0	0	0	1	0	0	0	0	0	0	1	0	
	△	↑								↑						↑									
	▽	↓								↓						↓									
	Brighter	1	1	1	1	1	1	0	1	1	1	1	1	1	0	1	1	1	1	1	1	1	0	1	
	▽	1	1	1	1	1	1	1	0	1	1	1	1	1	1	0	1	1	1	1	1	1	1	0	
	White	1	1	1	1	1	1	1	1	1	1	1	1	1	1	1	1	1	1	1	1	1	1	1	1

5.4 Power Sequence

To prevent a latch-up or DC operation of the Open Cell, the power on/off sequence shall be as shown in below.

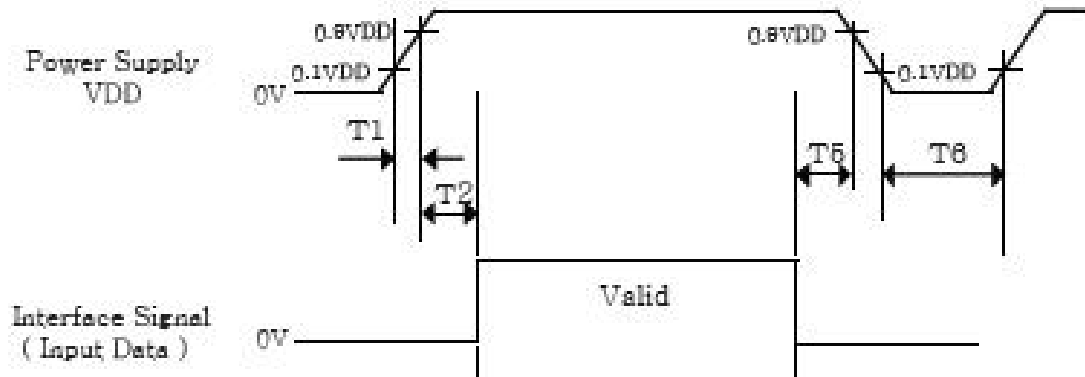

< Table 9. Sequence Table >

Parameter	Values			Units
	Min	Typ	Max	
T1	0.5	-	20	ms
T2	0	-	50	ms
T5	0	-	50	ms
T6	1	-	-	s

- Notes: 1. Even though T1 is over the specified value, there is no problem if I2T spec of fuse is satisfied.
 2. Back Light must be turn on after power for logic and interface signal are valid.

6.0 OPTICAL SPECIFICATIONS

The test of optical specifications shall be measured in a dark room (ambient luminance \leq 1 lux and temperature $=25\pm 2^{\circ}\text{C}$) with the equipment of Luminance meter system (Goniometer system and PR730) and test unit shall be located at an approximate distance 50cm from the LCD surface at a viewing angle of θ and Φ equal to 0° . We refer to $\theta_{\Phi=0} (= \theta_3)$ as the 3 o' clock direction (the "right"), $\theta_{\Phi=90} (= \theta_{12})$ as the 12 o' clock direction ("upward"), $\theta_{\Phi=180} (= \theta_9)$ as the 9 o' clock direction ("left") and $\theta_{\Phi=270} (= \theta_6)$ as the 6 o' clock direction ("bottom"). While scanning θ and/or Φ , the center of the measuring spot on the Display surface shall stay fixed. The measurement shall be executed after 30 minutes warm-up period. VDD shall be 12.0V \pm 10% at 25°C . Optimum viewing angle direction is 6' clock.

< Table 10. Optical Table >

[VDD = 12.0V, Frame rate = 60Hz, Ta = $25\pm 2^{\circ}\text{C}$]

Parameter		Symbol	Condition	Min	Typ	Max	Unit	Remark
Viewing Angle	Horizontal	Θ_3	CR > 10		89		Deg.	Note 1
		Θ_9			89		Deg.	
	Vertical	Θ_{12}			89		Deg.	
		Θ_6			89		Deg.	
Contrast ratio		CR			1200:1			Note 2
Luminance of White		Y_w			700		nit	Note3
White luminance uniformity		ΔY		75	80		%	Note4
Color Gamut					72		%	
Reproduction of color	White	W_x	$\Theta = 0^{\circ}$ (Center) Normal Viewing Angle		0.275			Note5 搭配YR 粉BLU
		W_y			0.300			
	Red	R_x			0.652			
		R_y			0.331			
	Green	G_x			0.287			
		G_y			0.617			
	Blue	B_x			0.147			
		B_y			0.084			
Response Time	G to G	T_g		-	8	-	ms	Note 6
Gamma Scale				2.0	2.2	2.4		
Cell Transmittance					6.0		%	

Note :

1. Viewing angle is the angle at which the contrast ratio is greater than 10. The viewing are determined for the horizontal or 3, 9 o' clock direction and the vertical or 6, 12 o' clock direction with respect to the optical axis which is normal to the LCD surface.
2. Contrast measurements shall be made at viewing angle of $\theta = 0^\circ$ and at the center of the LCD surface. Luminance shall be measured with all pixels in the view field set first to white, then to the dark (black) state. (See Figure 1 shown in Appendix) Luminance Contrast Ratio (CR) is defined mathematically.

$$CR = \frac{\text{Luminance when displaying a white raster}}{\text{Luminance when displaying a black raster}}$$

3. Center Luminance of white is defined as the LCD surface. Luminance shall be measured with all pixels in the view field set first to white. This measurement shall be taken at the locations shown in Figure 2 for a total of the measurements per display.
4. The White luminance uniformity on LCD surface is then expressed as :
 $\Delta Y = (\text{Minimum Luminance of 5 points} / \text{Maximum Luminance of 5 points}) * 100$
 (See Figure 2 shown in Appendix).
5. The color chromaticity coordinates specified in Table 10. shall be calculated from the spectral data measured with all pixels first in red, green, blue and white. Measurements shall be made at the center of the panel.
6. Response time T_g is the average time required for display transition by switching the input signal as below table and is based on Frame rate $f_v = 60\text{Hz}$ to optimize.

Measured Response Time	Target																
	0	15	31	47	63	79	95	111	127	143	159	175	191	207	223	239	255
0																	
15																	
31																	
47																	
63																	
79																	
95																	
111																	
127																	
143																	
159																	
175																	
191																	
207																	
223																	
239																	
255																	

BOE	PRODUCT GROUP	REV	ISSUE DATE
	TFT LCD	P0	2016.1.21

7.0 MECHANICAL CHARACTERISTICS

7.1 Dimensional Requirements

Figure 4(located in Appendix) shows mechanical outlines for the model DVB280FBM-NB1

Other parameters are shown in Table 11.

< Table 11. Dimensional Parameters >

Parameter	Specification	Unit
Dimensional outline	732(H) × 165(V)	mm
Weight	2.4	Kg
Active area	699.84(H)×131.22(V)	mm
Pixel pitch	121.5×364.5	um
Number of pixels	1920(H) ×360(V)	pixels

7.2 Mounting

See Figure 5 (Shown in Appendix)

SPEC. NUMBER	SPEC. TITLE DV280FBM-NB1 Product Specification	PAGE 19 of 29
--------------	---	------------------

8.0 Reliability Test Condition

< Table 12. Reliability Test Condition >

Item	Test Condition
High-Temp/OP	Ta = 60 °C, 240 hrs
Low-Temp/OP	Ta = 0 °C, 240 hrs
Low-Temp/STG	Ta = -20 °C, 240hrs
On/Off	30sec(on) / 30sec(off) , 12000times , 200hr
TST-2	-40°C~80°C(Per 30min) , 100 cycle
Altitude	先5000ft后15000ft ; 0°C/24hr ; 25°C/24hr ; 50°C/24hr
ESD	Front/Left @ Center ≤18dB , Rear/Inverter ≤25dB 150pF 330Ω ±15KV(Air) / ±8kV(Contact), 100point
Module VIB	Random : +X/+Y/+Z(30min) ; 1.5G ; 10~500HZ
Shock	50G 11msec ; Half sine ; ±X±Y±Z axis

This test condition is based on BOE module.

BOE	PRODUCT GROUP	REV	ISSUE DATE
	TFT LCD	P0	2016.1.21

9.0 PRODCUT SERIAL NUMBER

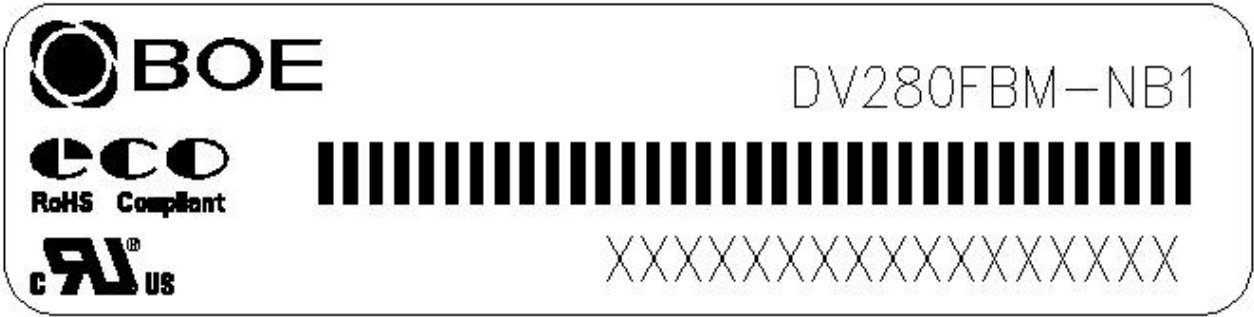

Remark:

贴附位置: 背板

标签尺寸: 48mm × 12mm, 料号: 44-9231007

1. FG-CODE
2. MDL ID (编码规则如下)
3. MDL ID 条形码

序列号	1	2	3	4	5	6	7	8	9	10	11	12	13	14	15	16	17
代码	4	F	P	3	1	2	7	3	8	0	0	0	0	1	E	E	J
描述	GBN代码		等级	B3	年	周		FG Code后四位				序列号					

SPEC. NUMBER	SPEC. TITLE DV280FBM-NB1 Product Specification	PAGE 21 of 29
--------------	---	------------------

BOE	PRODUCT GROUP	REV	ISSUE DATE
	TFT LCD	P0	2016.1.21

10.0 PACKING INFORMATION

BOE provides the standard shipping container for customers, unless customer specifies their packing information. The standard packing method and Barcode information are shown in below.

10.1 Packing Order

- 将 EPE Conner & Bottom 放入Inner Box
- 将MDL 套入PE Bag 后PCB 向上竖直插入

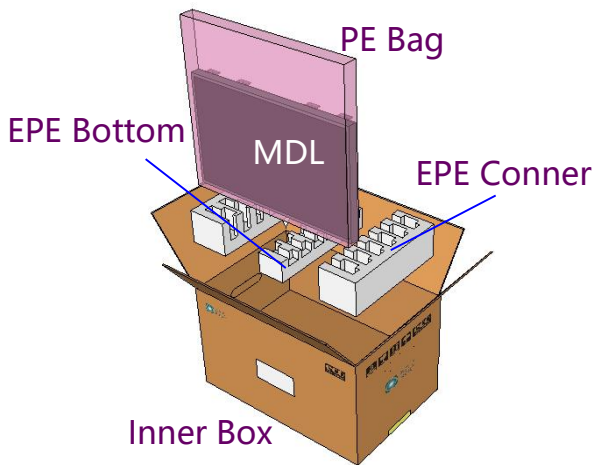

- 将4pcs MDL 插入卡槽后
- EPE Cover 扣合
- 4pcs/Box

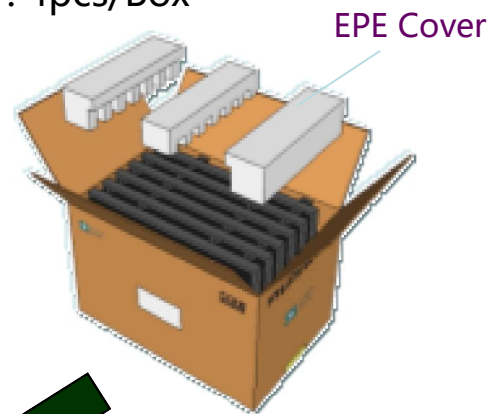

- 每个Pallet上放4层Box
- 1层4箱,共计16ea Box
- Pallet外进行缠膜包装
- 64pcs Panel / Pallet



SPEC. NUMBER	SPEC. TITLE DV280FBM-NB1 Product Specification	PAGE 22 of 29
--------------	---	------------------

BOE	PRODUCT GROUP	REV	ISSUE DATE
	TFT LCD	P0	2016.1.21

10.2 Packing Note

- Box Dimension : 815mm(L) × 253mm (W) ×250mm (H)
- Package Quantity in one Box : 4pcs

10.3 Box Label

- Label Size : 110 mm (L) × 55 mm (W)
- Contents
 1. FG-CODE
 2. Box 产品数量
 3. Box ID, 编码规则如下
 4. Box Packing 日期
 5. FG-CODE 后四位

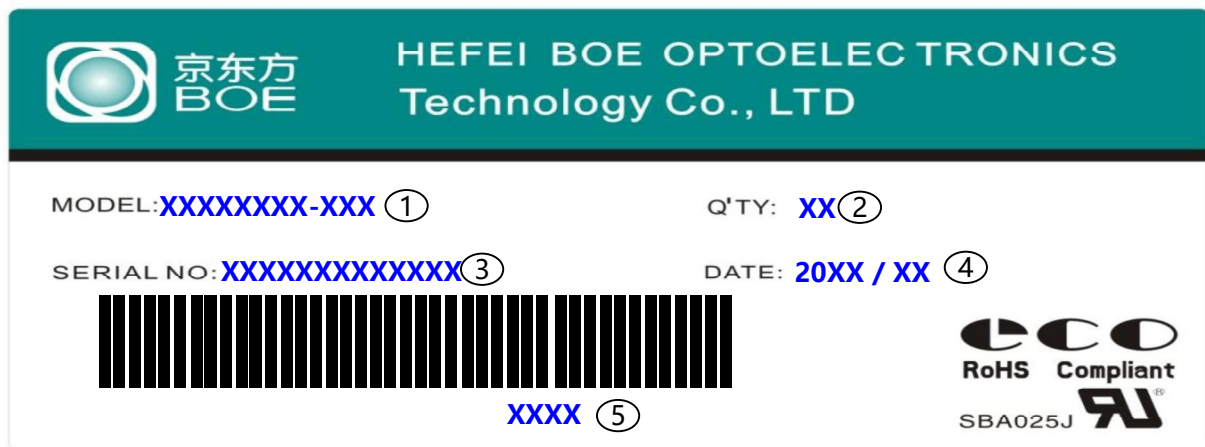

序号号	1	2	3	4	5	6	7	8	9	10	11	12	13
代码	X	X	P	3	1	5	7	0	0	0	1	H	D
描述	GBN代码		等级	B3	年份		月	Rev	序列号				

SPEC. NUMBER	SPEC. TITLE DV280FBM-NB1 Product Specification	PAGE 23 of 29
--------------	---	------------------

BOE	PRODUCT GROUP	REV	ISSUE DATE
	TFT LCD	P0	2016.1.21

11.0 HANDLING & CAUTIONS

- (1) Cautions when taking out the module
 - Pick the pouch only, when taking out module from a shipping package.
- (2) Cautions for handling the module
 - As the electrostatic discharges may break the LCD module, handle the LCD module with care. Peel a protection sheet off from the LCD panel surface as slowly as possible.
 - As the LCD panel and back - light element are made from fragile glass material, impulse and pressure to the LCD module should be avoided.
 - As the surface of the polarizer is very soft and easily scratched, use a soft dry cloth without chemicals for cleaning.
 - Do not pull the interface connector in or out while the LCD module is operating.
 - Put the module display side down on a flat horizontal plane.
 - Handle connectors and cables with care.
- (3) Cautions for the operation
 - When the module is operating, do not lose CLK, ENAB signals. If any one of these signals is lost, the LCD panel would be damaged.
 - Obey the supply voltage sequence. If wrong sequence is applied, the module would be damaged.
- (4) Cautions for the atmosphere
 - Dew drop atmosphere should be avoided.
 - Do not store and/or operate the LCD module in a high temperature and/or humidity atmosphere. Storage in an electro-conductive polymer packing pouch and under relatively low temperature atmosphere is recommended.
- (5) Cautions for the module characteristics
 - Do not apply fixed pattern data signal to the LCD module at product aging.
 - Applying fixed pattern for a long time may cause image sticking.
- (6) Other cautions
 - Do not disassemble and/or re-assemble LCD module.
 - Do not re-adjust variable resistor or switch etc.
 - When returning the module for repair or etc., Please pack the module not to be broken. We recommend to use the original shipping packages.

SPEC. NUMBER	SPEC. TITLE DV280FBM-NB1 Product Specification	PAGE 24 of 29
--------------	---	------------------

12.0 APPENDIX

< Figure 1. Measurement Set Up >

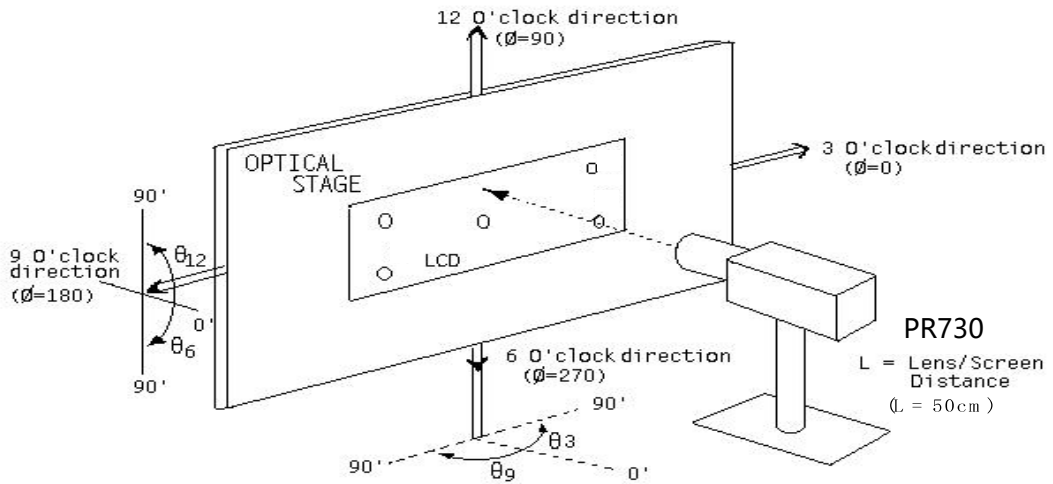

SPEC. NUMBER	SPEC. TITLE DV280FBM-NB1 Product Specification	PAGE 25 of 29
--------------	---	------------------

12.0 APPENDIX

< Figure 2. White Luminance and Uniformity Measurement Locations >

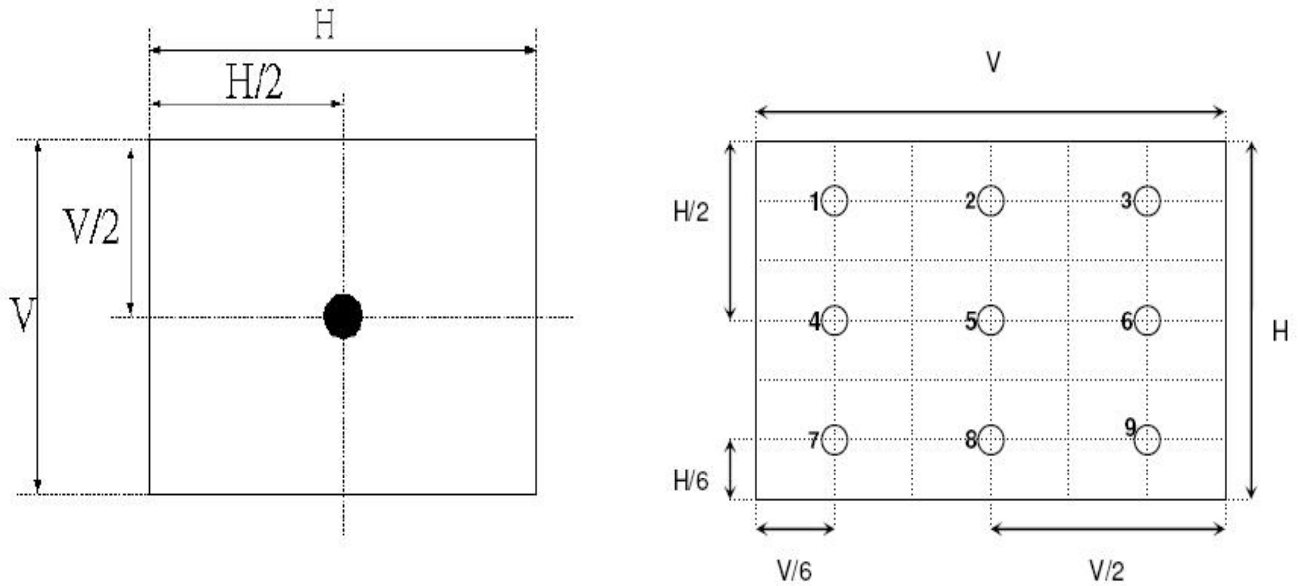

< Figure 2. Response Time Testing >

Any level of gray (Bright)

Any level of gray (Dark)

Any level of gray (Bright)

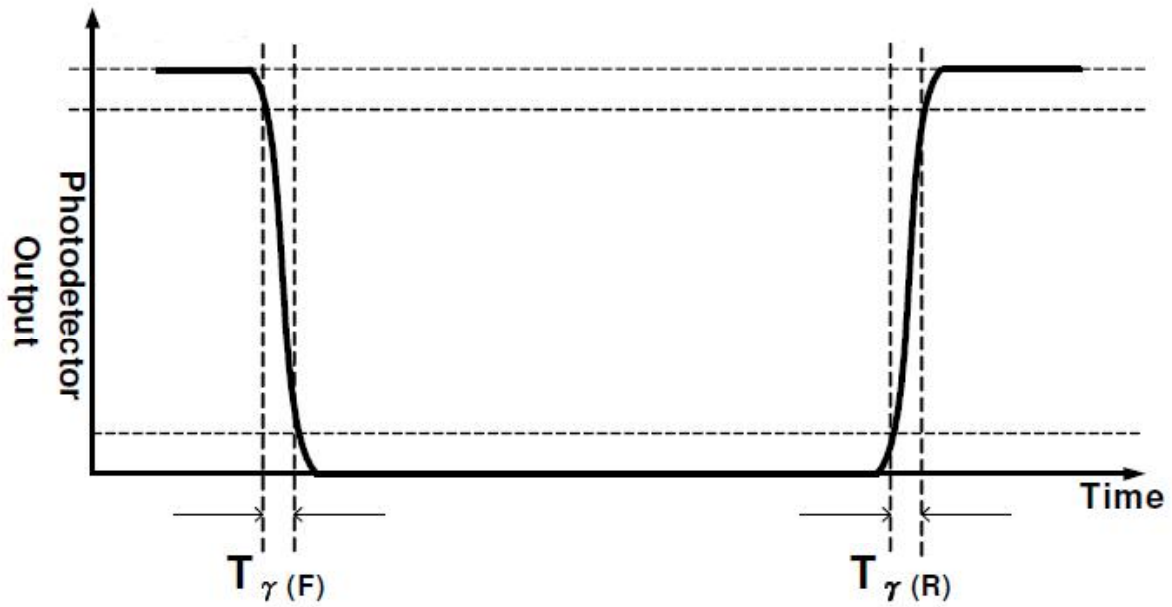

< Figure 3. TFT-LCD Module Outline Dimensions (Front View) >

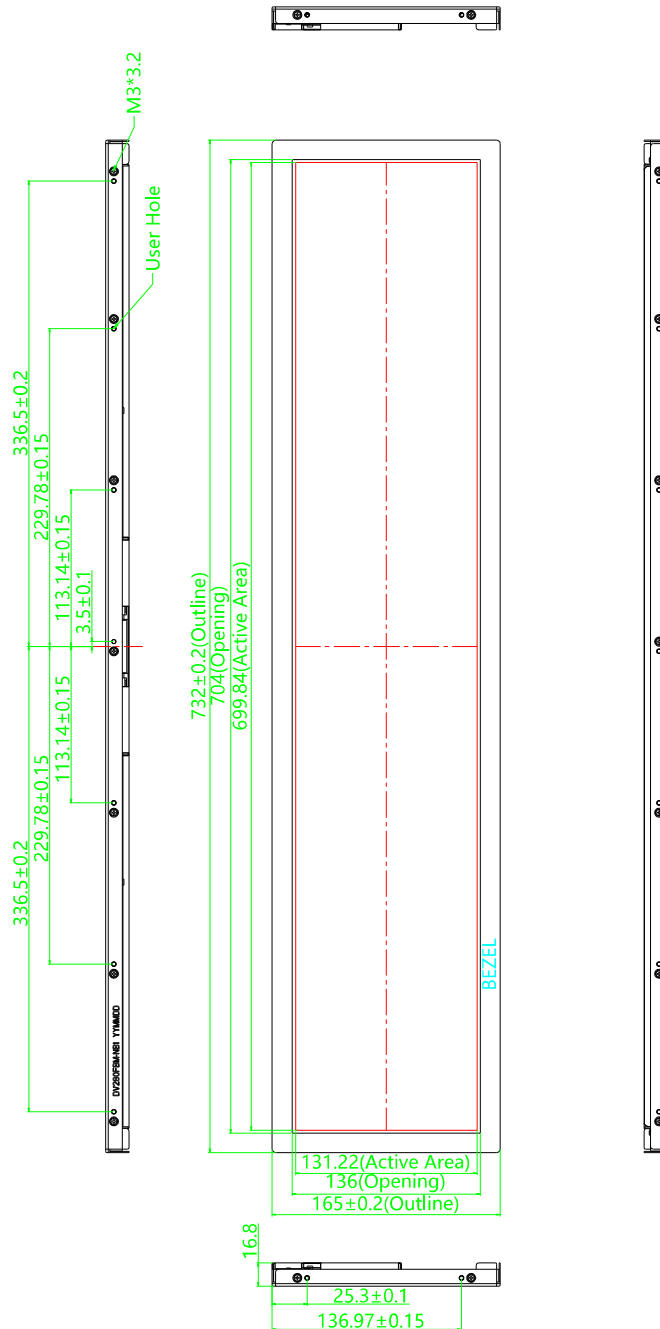

< Figure 4. TFT-LCD Module Outline Dimensions (Rear View) >

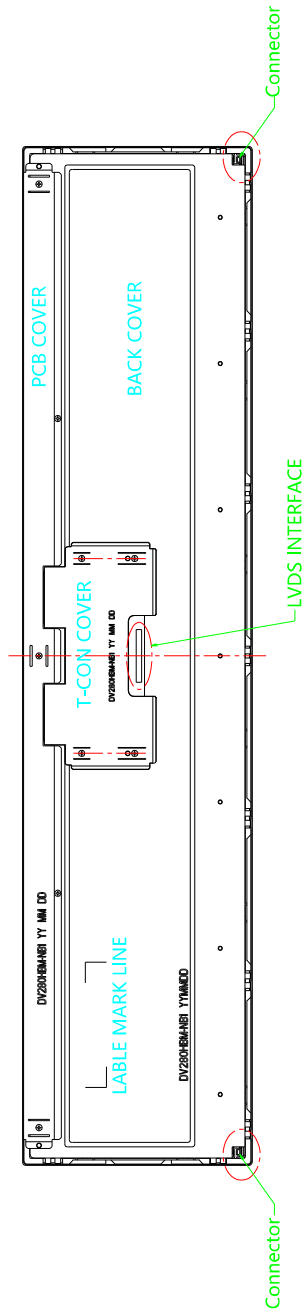

DATA MODUL



ALL TECHNOLOGIES. ALL COMPETENCIES. ONE SPECIALIST.



DATA MODUL AG
Landsberger Straße 322
DE-80687 Munich
Phone: +49-89-56017-0

DATA MODUL WEIKERSHEIM GMBH
Lindenstraße 8
DE-97990 Weikersheim
Phone: +49-7934-101-0



More information and worldwide locations can be found at

www.data-modul.com