



# SPECIFICATION

---

**BOE**

DV320FHM-NN0

32,0" TFT - FHD - LVDS

Version: 1.0

Date: 11.07.2019

Note: This specification is subject to change without prior notice



**PROPRIETARY NOTE**

THIS SPECIFICATION IS THE PROPERTY OF BOE DT AND SHALL NOT BE REPRODUCED OR COPIED WITHOUT THE WRITTEN PERMISSION OF BOE DT AND MUST BE RETURNED TO BOE DT UPON ITS REQUEST

**TITLE: DV320FHM-NN0**  
**Product Specification**  
**Rev. A**

BEIJING BOE DISPLAY TECHNOLOGY

<b>SPEC. NUMBER</b> S8-64-8A-130	<b>PRODUCT GROUP</b> TFT-LCD	<b>REV.</b> A	<b>ISSUE DATE</b> 2019.7.11	<b>PAGE</b> 1 OF 36
-------------------------------------	---------------------------------	------------------	--------------------------------	------------------------



**Contents**

No	ITEM	Page
	REVISIONS HISTORY	2
	CONTENTS	3
1	GENERAL DESCRIPTION	4
	1.1 Introduction	
	1.2 Features	
	1.3 Applications	
	1.4 General Specification	
2	ABSOLUTE MAXIMUM RATINGS	6
3	ELECTRICAL SPECIFICATIONS	8
	3.1 TFT LCD Module	
	3.2 Interface Connections	
	3.3 Backlight Unit	
	3.4 LED Constant Current Source LED	
	3.5 Signal Timing Specifications	
	3.6 Signal Timing Waveform	
	3.7 Color Data Input Assignment	
	3.8 Power Sequence	
	3.9 Mini-LVDS Signal Specifications	
4	OPTICAL SPECIFICATIONS	19
	4.1 Test Conditions	
	4.2 Optical Specifications	
5	MECHANICAL CHARACTERISTICS	23
6	RELIABILITY	24
7	PRODUCT SERIAL NUMBER	25
8	PACKING INFORMATION	26
9	HANDLING & CAUTIONS	29
10	APPENDIX ( 包括 Mechanical Outline Dimension )	35

## 1.0 GENERAL DESCRIPTION

### 1.1 Introduction

DV320FHM-NN0 is a color active matrix TFT LCD MDL using amorphous silicon TFT's (Thin Film Transistors) as an active switching devices. This open cell has a 31.51 inch diagonally measured active area with FHD resolutions (1920 horizontal by 1080 vertical pixel array). Each pixel is divided into RED, GREEN, BLUE dots which are arranged in vertical stripe and this open cell can display 16.7M colors. The TFT-LCD panel used for this open cell is adapted for a low reflection and higher color type.

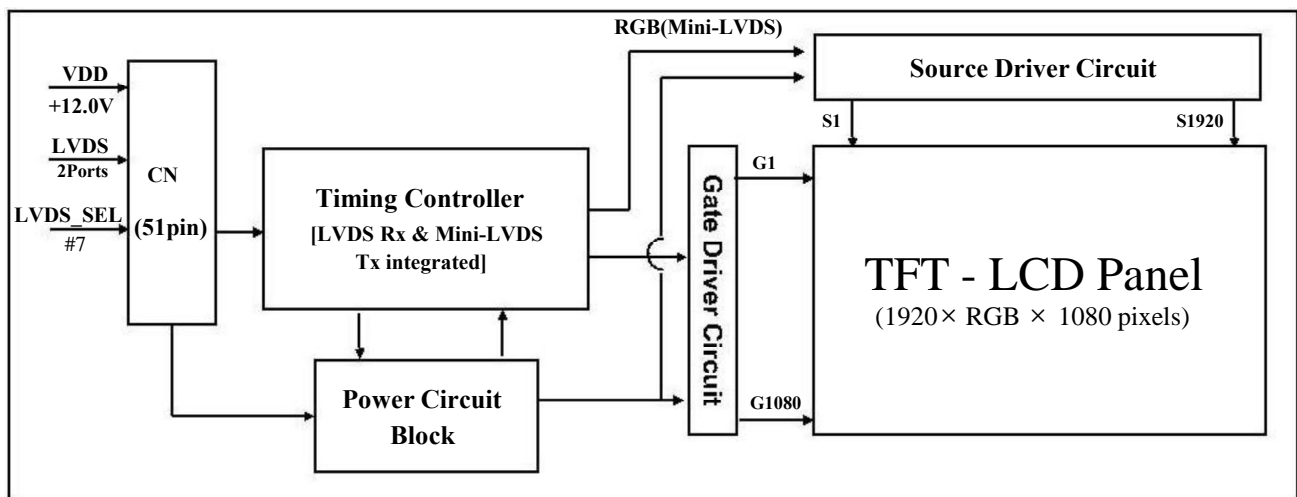

### 1.2 Features

- LVDS interface with 2 pixel / clock
- High-speed response
- Low color shift image quality
- 8-bit color depth, display 16.7M colors
- High luminance and contrast ratio, low reflection and wide viewing angle
- DE (Data Enable) only mode
- ADSDS technology is applied for high display quality
- RoHS compliant

### 1.3 Application

- Commercial Digital Display
- Display Terminals for Control System
- Landscape and Portrait Display

### 1.4 General Specification

< Table 1. General Specifications >

Parameter	Specification	Unit	Remark
Active area	698.4(H) × 392.85 (V)	mm	
Number of pixels	1920(H) × 1080(V)	pixels	
Pixel pitch	121.25(H) × RGB × 363.75(V)	μm	
Pixel arrangement	Pixels RGB Vertical stripe		
Display colors	16.7M(8bits-true)	colors	
Display mode	Transmission mode, Normally Black		
Open Cell Transmittance	5.0 (Typ.)	%	At center point with BOE BLU
Weight	4.0(Typ)	Kg	
Power Consumption	39W	Watt	
Surface Treatment	Haze 1%		

## 2.0 ABSOLUTE MAXIMUM RATINGS

### 2.1 ABSOLUTE RATINGS OF ENVIRONMENT

The followings are maximum values which, if exceed, may cause faulty operation or damage to the unit. The operational and non-operational maximum voltage and current values are listed in Table 2.

< Table 2. Open Cell Electrical Specifications >

[VSS=GND=0V]

Parameter	Symbol	Min.	Max.	Unit	Remark
Power Supply Voltage	VDD	VSS-0.3	14	V	Ta = 25 °C
Operating Temperature	T <sub>OP</sub>	0	+50	°C	Note 1
	T <sub>SUR</sub>	0	+60	°C	
Storage Temperature	T <sub>ST</sub>	-20	+60	°C	
Operating Ambient Humidity	H <sub>OP</sub>	10	80	%RH	
Storage Humidity	H <sub>ST</sub>	10	80	%RH	

Note 1 : Temperature and relative humidity range are shown in the figure below.  
Wet bulb temperature should be 39 °C max. and no condensation of water.

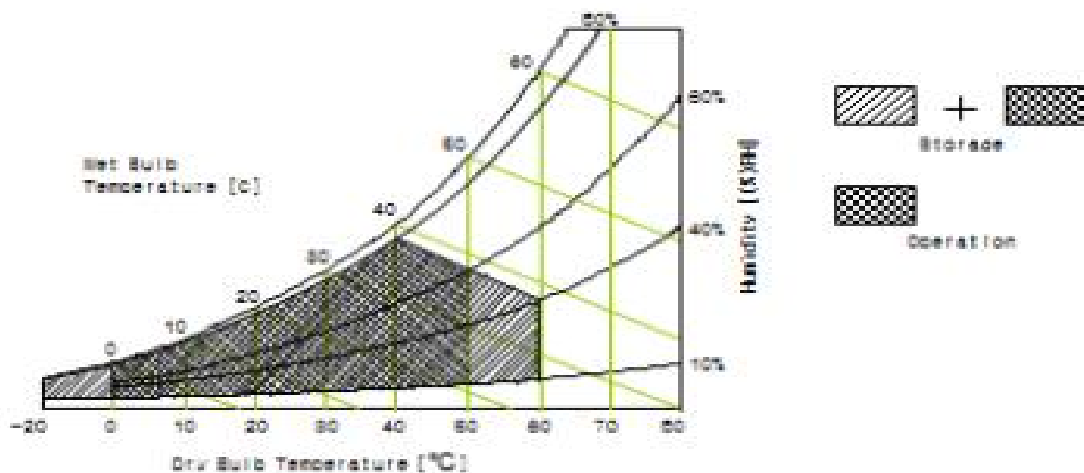

### 2.2 ABSOLUTE RATINGS OF ENVIRONMENT

When storing modules as spares for a long time, the following precaution is necessary.

- (a) Do not leave the module in high temperature, and high humidity for a long time. It is highly recommended to store the module with temperature from 20 to 25°C at and 50 ± 10%RH.
- (b) The module shall be stored in dark place. Do not store the TFT-LCD module in direct sunlight or fluorescent light.



## 2.3 ELECTRICAL ABSOLUTE RATINGS

< Table 3. Electrical Absolute Ratings(Open Cell) >

Item	Symbol	Value		Unit	Note
		Min	Max		
Power Supply Voltage	VDD	VSS-0.3	14	V	(1)
Logic Input Voltage	Vin	-0.3	3.6	V	

< Table 4 Backlight Unit >

Item	Symbol	Value			Unit	Note
		Min.	Typ	Max.		
LED DC forward current	If	-	540	-	mA	
LED peak pulse	Ip	-		-	mA	
LED Reverse voltage	Vr	3.0	3.2	3.4	V	

Note (1)Permanent damage to the device may occur if maximum values are exceeded. Function operation should be restricted to the conditions described under normal operating conditions.



## 3.0 ELECTRICAL CHARACTERISTICS

### 3.1 TFT LCD MOUDLE

< Table 5. Open Cell Electrical Specifications >

[Ta =25 ± 2 °C]

Parameter		Symbol	Values			Unit	Remark
			Min	Typ	Max		
Power Supply Input Voltage		VDD	10.8	12	14	Vdc	
Power Supply Ripple Voltage		VRP			300	mV	
Power Supply Current		IDD	-	333	630	mA	Note 1
Power Consumption		PDD		4.0	7.6	Watt	
Rush current		IRUSH	-	-	3.3	A	Note 2
LVDS Interface	LVDS Swing Voltage	VID	±100		±300	mV	Note 3
	Common Input Voltage	VLVC	1.0	1.2	1.4	V	
CMOS Interface	Input High Threshold Voltage	VIH	2.7	-	3.3	V	
	Input Low Threshold Voltage	VIL	0	-	0.6	V	

Note 1 : The supply voltage is measured and specified at the interface connector of LCM.

The current draw and power consumption specified is for VDD=12.0V,

Frame rate  $f_p=60\text{Hz}$  and Clock frequency = 75.4MHz.

Test Pattern of power supply current

a) Typ : Mosaic 7X5 (L0/L255)

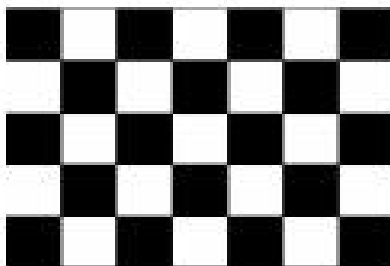

b) Max : Horizontal 1 Line (L0/L255)



c) Flicker Pattern



Note 2 : The duration of rush current is about 2ms and rising time of Power Input is 1ms(min)

Note 3 : The LVDS test point is at each terminal resistor

## 3.2 INTERFACE CONNECTIONS

### 3.2.1 LCD MODULE

- Connector : IS050-C51B-C39-S (UJU) / FI-RE51S-HF-R1500 (JAE) or Equivalent.

< Table 6. Open Input Connector Pin Configuration >

Pin No	Symbol	Description	Pin No	Symbol	Description
1	NC	No Connection	21	GND	Ground
2	SDA	I <sup>2</sup> C Data	22	CH1[3]-	First pixel negative LVDS differential data input. Pair3
3	SCL	I <sup>2</sup> C Clock	23	CH1[3]+	First pixel positive LVDS differential data input. Pair3
4	NC	Not Connected	24	NC	Not Connected
5	NC	Not Connected	25	NC	Not Connected
6	NC	Not Connected	26	NC or GND	Not Connected
7	SELLVDS	High: JEIDA Low or Open: VESA	27	NC	Not Connected
8	NC	Not Connected	28	CH2[0]-	Second pixel negative LVDS differential data input. Pair0
9	NC	Not Connected	29	CH2[0]+	Second pixel positive LVDS differential data input. Pair0
10	NC	Not Connected	30	CH2[1]-	Second pixel negative LVDS differential data input. Pair1
11	GND	Ground	31	CH2[1]+	Second pixel positive LVDS differential data input. Pair1
12	CH1[0]-	First pixel negative LVDS differential data input. Pair0	32	CH2[2]-	Second pixel negative LVDS differential data input. Pair2
13	CH1[0]+	First pixel positive LVDS differential data input. Pair0	33	CH2[2]+	Second pixel positive LVDS differential data input. Pair2
14	CH1[1]-	First pixel negative LVDS differential data input. Pair1	34	GND	Ground
15	CH1[1]+	First pixel positive LVDS differential data input. Pair1	35	CH2CLK-	Second pixel negative LVDS clock
16	CH1[2]-	First pixel negative LVDS differential data input. Pair2	36	CH2CLK+	Second pixel positive LVDS clock
17	CH1[2]+	First pixel positive LVDS differential data input. Pair2	37	GND	Ground
18	GND	Ground	38	CH2[3]-	Second pixel negative LVDS differential data input. Pair3
19	CH1CLK-	First pixel negative LVDS clock	39	CH2[3]+	Second pixel positive LVDS differential data input. Pair3
20	CH1CLK+	First pixel positive LVDS clock			

Pin No	Symbol	Description	Pin No	Symbol	Description
40	NC	Not Connected	46	GND	Ground
41	NC	Not Connected	47	NC	Not Connected
42	NC or GND	Not Connected	48	VCC	Input Voltage +12V
43	NC or GND	Not Connected	49	VCC	Input Voltage +12V
44	NC or GND	Ground	50	VCC	Input Voltage +12V
45	GND	Ground	51	VCC	Input Voltage +12V

- Notes : 1. NC(Not Connected) : This pins are only used for BOE internal operations.  
 2. Input Level of LVDS signal is based on the IEA 664 Standard.  
 3. LVDS\_SEL : This pin is used for selecting LVDS signal data format.  
 If this Pin : High (3.3V) → JEIDA LVDS format  
 Otherwise : Low (GND) or Open (NC) → Normal NS LVDS format

### Rear view of LCM



### BIST Pattern

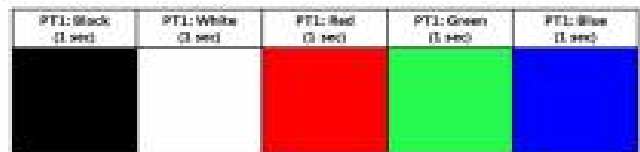

## 3.3 BACKLIGHT UNIT

### 3.3.1 LED LIGHTBAR UNIT CHARACTERISTICS (Ta = 25 ± 2 °C)

< Table 7. LED Lightbar Unit Characteristics >

Parameter	Symbol	Value			Unit	Note
		Min.	Typ.	Max.		
Lightbar input Voltage	V	60	64	68	V <sub>RMS</sub>	One channel
Lightbar input current	I <sub>L</sub>	520	540	560	mA	One channel
Power consume	W	31.2	34.56	38.08	W	One channel
Lightbar Life Time	L <sub>BL</sub>	30,000	-	-	Hrs	

Note (1) The lifetime is defined as the time which luminance of the LED decays to 50% compared to the initial value, Operating condition: Continuous operating at  $T_a = 25 \pm 2^\circ\text{C}$ ,  $I_L = 540\text{mA}$

The pin configuration for the housing and leader wire is shown in the table below. Light bar connector type: **CI0102S0000-A, PITCH=2mm**

Pin No.	Symbol	Description	Wire Color
1	+	CH+	Red
2	-	CH-	WHITE

LED Numbers:  $20 \times 6 = 120$

Total: 20 LED / BLU

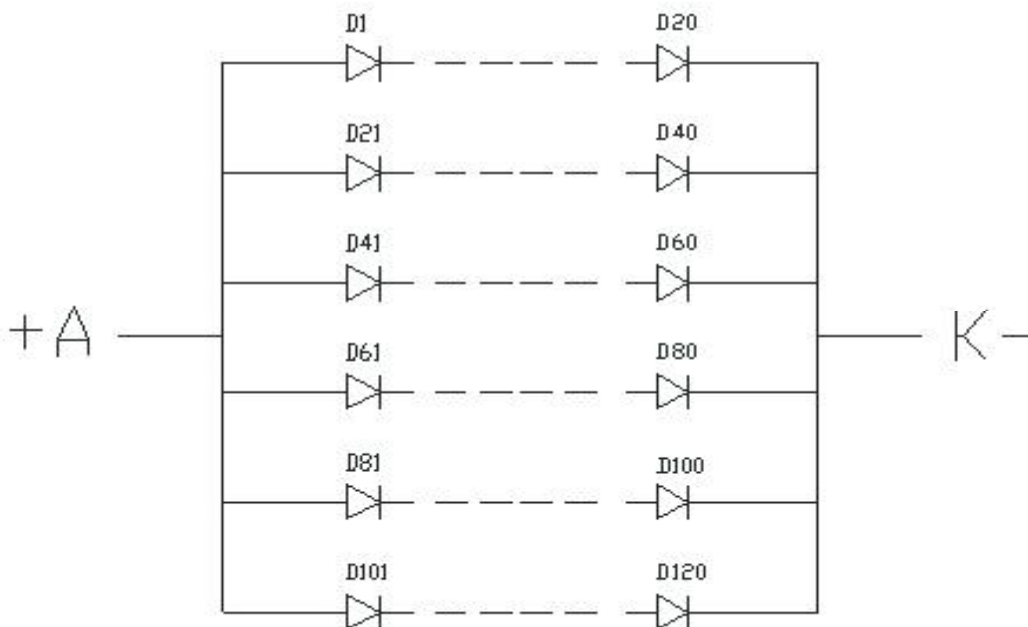

### 3.4 LED Constant current source LED

#### 3.4.1 Input Electrical Characteristics

< Table 8 Input Electrical Characteristics >

NO	Item	Symbol	Min	Type	Max	Unit
1	Input Voltage	Vin	20.8	24	26	V
2	Input Current	Iin		0.7	2	A
3	Input Power	Pin		36	52	W
4	Brightness Voltage	Vadj	0(bright)	---	5 (dark)	V
5	Control Voltage	Enable Von=1.5---5.0V Disable Voff=0---0.5V				

#### 3.4.2 Out Electrical Characteristics

< Table 9 Output Electrical Characteristics >

Item	Symbol	Test Conditions	Min	Type	Max	Unit
Output Current (per group)	Iout	Vin=24.0V; Vout=57V; Ta=28°C		540	750	mA
Output Voltage	Vout	Vin=24.0V; Ta=28°C	30	66	85	V
Efficiency	η	Vin=24.0V; Vout=57V;		92.5		%
Output total group	Ggp			1		
The Total Output Current	R	According to the backlight parameters to adjust output current		540	750	MA
output power	W out	Vin=24.0V; Vout=30-85V;		36	63.75	W

The parameter of upon will change when the LCD module changes

### 3.4.3 Pin Assignments

< Table 10 Pin Assignments >

The pin configuration for the housing and leader wire is shown in the table below. CN1 connector type: **CI0114S0000, PITCH=2mm**

Input connector: CN1			
Pin No.	Symbol	Description	Parameter
1、 2、 3、 4、 5	+24V	Supply voltage	22~26V
6、 7、 8、 9、 10	GND	Ground	0V
13	ADJ	Dimming control	0V=Brightness Max 5V=Brightness Min
12	N/F	Standby/Operation	On =1-5.0V Off=0-0.5V
14、 11	NC		

Output Socket: CN3			
Pin No.	Symbol	Description	Parameter
1	OUT+	Output voltage	30-85V
2	OUT-	Ground	0

The above output parameters are determined according to the optical requirement.  
The products are not intended for use in systems in which failures of product could result in personal injury.

### 3.5 Signal Timing Specifications

Timing Parameters (DE only mode)

< Table 12 Timing Table >

Item		Symbols		Min	Typ	Max	Unit
Clock	Frequency	1/Te		58	74.25 (92.8)	97	MHz
	High Time	Teh		-	4/7Te	-	
	Low Time	Tel		-	4/7Te	-	
Frame Period		Tv		1100	1125	1149	lines
				47	60 (75)	78	Hz
Horizontal Active Display Term		Valid	t <sub>HV</sub>	-	960	-	t <sub>CLK</sub>
		Total	t <sub>HP</sub>	1060	1100	1200	t <sub>CLK</sub>
Vertical Active Display Term		Valid	t <sub>VV</sub>	-	1080	-	t <sub>HP</sub>
		Total	t <sub>VP</sub>	1100	1125	1149	t <sub>HP</sub>

Notes: This product is DE only mode. The input of Hsync & Vsync signal does not have an effect on normal operation.

< Table 13 LVDS Input SSCG >

Symbol	Parameter	Condition	Min	Typ	Max	Unit
F	LVDS Input frequency	-	58	74.25 (92.8)	97	MHz
T <sub>LVSK</sub>	LVDS channel to channel skew	F=100MHz V <sub>IC</sub> =1.2V V <sub>ID</sub> =±200mV	-(1/F)*30%	-	(1/F)*30%	ps
F <sub>LVMOD</sub>	Modulating frequency of input clock during SSC	F=85MHz V <sub>IC</sub> =1.2V V <sub>ID</sub> =±200mV	0	-	200	KHz
F <sub>LVDEV</sub>	Maximum deviation of input clock frequency during SSC		-3	-	+3	%
T <sub>CYCY</sub>	Cycle to Cycle jitter		-	-	50	ps



### 3.6 Signal Timing Waveform

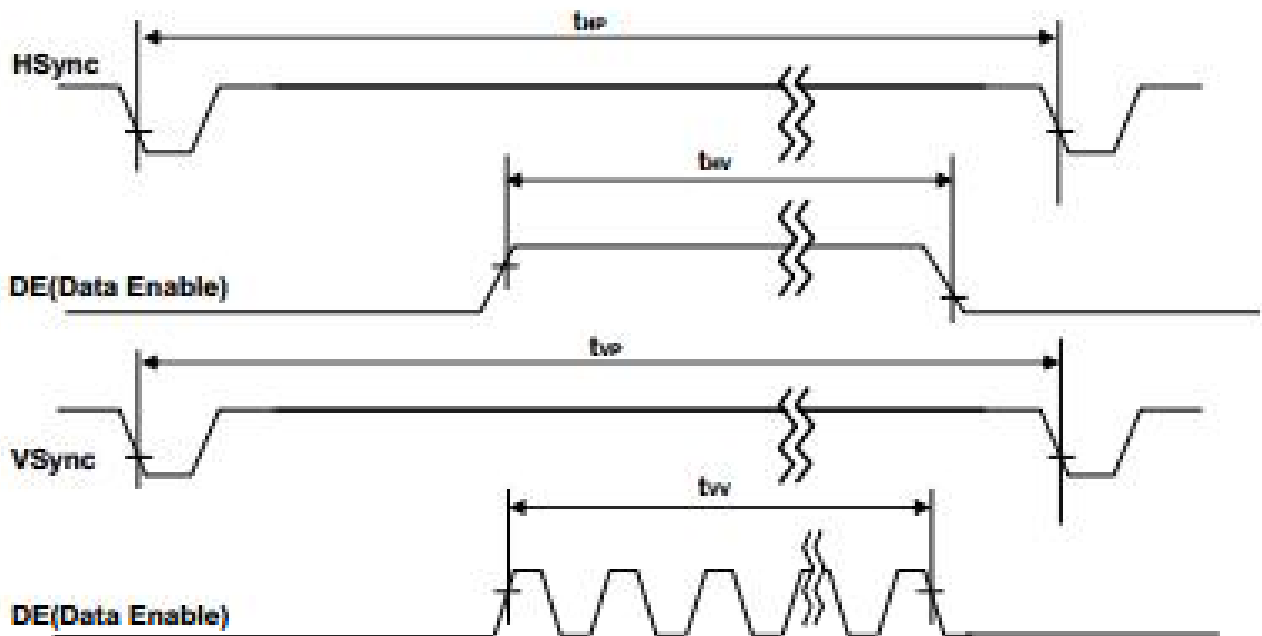
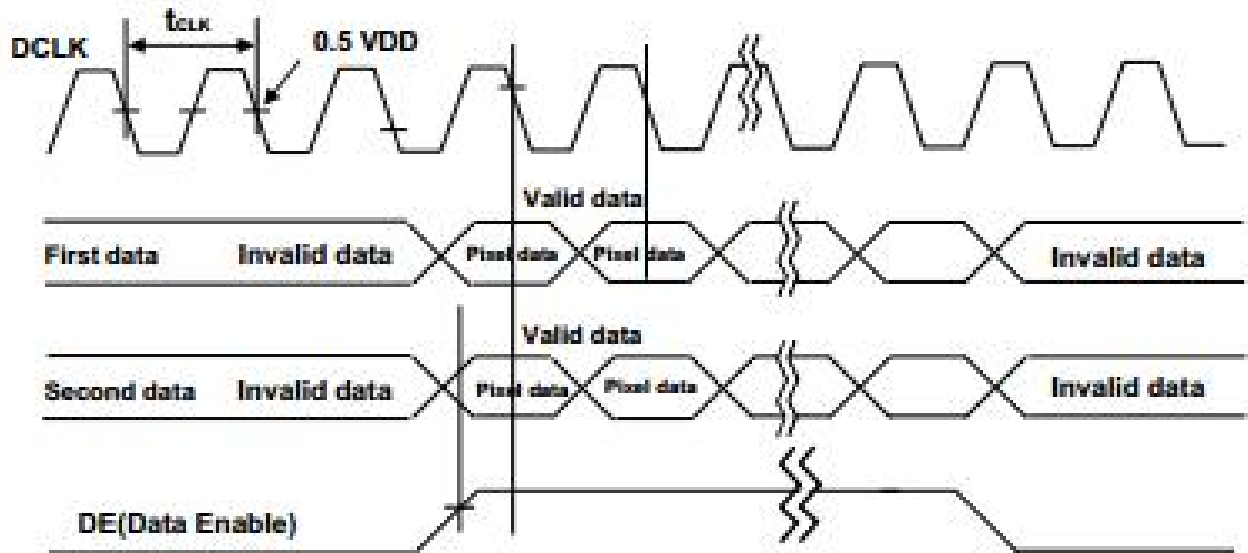

### 3.7 COLOR DATA INPUT ASSIGNMENT

Input Signals, Basic Display Colors and Gray Scale of Colors

< Table 14 Input Signal and Display Color Table >

Color & Gray Scale		Input Data Signal																							
		Red Data								Green Data								Blue Data							
		R7	R6	R5	R4	R3	R2	R1	R0	G7	G6	G5	G4	G3	G2	G1	G0	B7	B6	B5	B4	B3	B2	B1	B0
Basic Colors	Black	0	0	0	0	0	0	0	0	0	0	0	0	0	0	0	0	0	0	0	0	0	0	0	
	Blue	0	0	0	0	0	0	0	0	0	0	0	0	0	0	0	0	1	1	1	1	1	1	1	
	Green	0	0	0	0	0	0	0	0	1	1	1	1	1	1	1	1	0	0	0	0	0	0	0	
	Cyan	0	0	0	0	0	0	0	0	1	1	1	1	1	1	1	1	1	1	1	1	1	1	1	
	Red	1	1	1	1	1	1	1	1	0	0	0	0	0	0	0	0	0	0	0	0	0	0	0	
	Magenta	1	1	1	1	1	1	1	1	0	0	0	0	0	0	0	0	1	1	1	1	1	1	1	
	Yellow	1	1	1	1	1	1	1	1	1	1	1	1	1	1	1	1	0	0	0	0	0	0	0	
	White	1	1	1	1	1	1	1	1	1	1	1	1	1	1	1	1	1	1	1	1	1	1	1	
Gray Scale of Red	Black	0	0	0	0	0	0	0	0	0	0	0	0	0	0	0	0	0	0	0	0	0	0		
	△	0	0	0	0	0	0	0	1	0	0	0	0	0	0	0	0	0	0	0	0	0	0		
	Darker	0	0	0	0	0	0	0	1	0	0	0	0	0	0	0	0	0	0	0	0	0	0		
	△																								
	▽																								
	Brighter	1	1	1	1	1	1	0	1	0	0	0	0	0	0	0	0	0	0	0	0	0	0		
	▽	1	1	1	1	1	1	1	0	0	0	0	0	0	0	0	0	0	0	0	0	0	0		
	Red	1	1	1	1	1	1	1	1	0	0	0	0	0	0	0	0	0	0	0	0	0	0	0	
Gray Scale of Green	Black	0	0	0	0	0	0	0	0	0	0	0	0	0	0	0	0	0	0	0	0	0	0		
	△	0	0	0	0	0	0	0	0	0	0	0	0	0	0	0	1	0	0	0	0	0	0		
	Darker	0	0	0	0	0	0	0	0	0	0	0	0	0	0	0	1	0	0	0	0	0	0		
	△																								
	▽																								
	Brighter	0	0	0	0	0	0	0	0	1	1	1	1	1	1	0	1	0	0	0	0	0	0		
	▽	0	0	0	0	0	0	0	0	1	1	1	1	1	1	0	0	0	0	0	0	0	0		
	Green	0	0	0	0	0	0	0	0	1	1	1	1	1	1	1	0	0	0	0	0	0	0	0	
Gray Scale of Blue	Black	0	0	0	0	0	0	0	0	0	0	0	0	0	0	0	0	0	0	0	0	0	0		
	△	0	0	0	0	0	0	0	0	0	0	0	0	0	0	0	0	0	0	0	0	0	1		
	Darker	0	0	0	0	0	0	0	0	0	0	0	0	0	0	0	0	0	0	0	0	0	1		
	△																								
	▽																								
	Brighter	0	0	0	0	0	0	0	0	0	0	0	0	0	0	0	1	1	1	1	1	1	0		
	▽	0	0	0	0	0	0	0	0	0	0	0	0	0	0	0	1	1	1	1	1	1	0		
	Blue	0	0	0	0	0	0	0	0	0	0	0	0	0	0	0	1	1	1	1	1	1	1		
Gray Scale of White	Black	0	0	0	0	0	0	0	0	0	0	0	0	0	0	0	0	0	0	0	0	0	0		
	△	0	0	0	0	0	0	0	1	0	0	0	0	0	0	0	1	0	0	0	0	0	1		
	Darker	0	0	0	0	0	0	0	1	0	0	0	0	0	0	1	0	0	0	0	0	0	1		
	△																								
	▽																								
	Brighter	1	1	1	1	1	1	0	1	1	1	1	1	1	0	1	1	1	1	1	1	1	0		
	▽	1	1	1	1	1	1	1	0	1	1	1	1	1	1	0	1	1	1	1	1	1	0		
	White	1	1	1	1	1	1	1	1	1	1	1	1	1	1	1	1	1	1	1	1	1	1		

### 3.8 POWER SEQUENCE

To prevent a latch-up or DC operation of the Open Cell, the power on/off sequence shall be as shown in below.

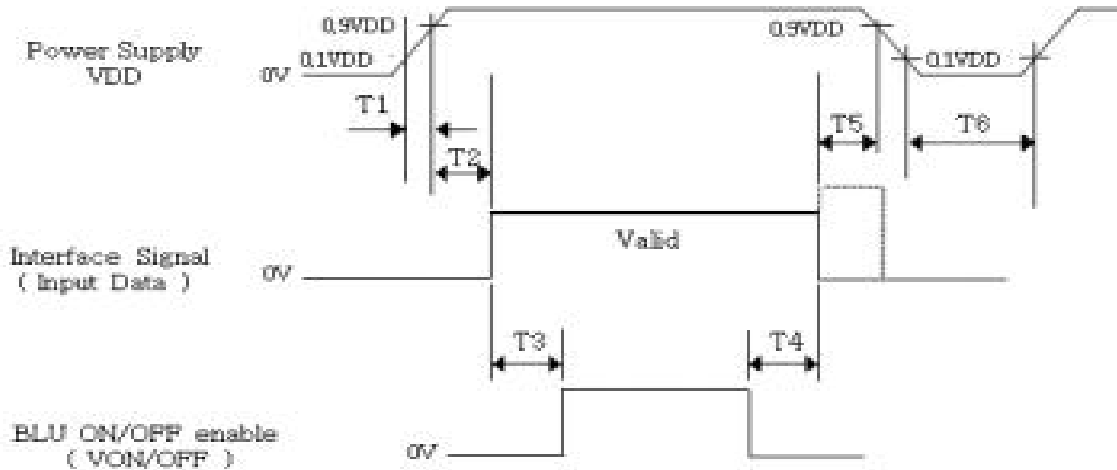

< Table 15 Sequence Table >

Parameter	Values			Units
	Min	Typ	Max	
T1	0.5	-	20	ms
T2	10	-	-	ms
T3	200	-	-	ms
T4	100	-	-	ms
T5	0	-	-	ms
T6	1	-	-	s

Notes: 1. Back Light must be turn on after power for logic and interface signal are valid.  
2. Even though T1 is out of SPEC, it is still ok if the inrush current of VDD is below the limit.

### 3.9 MINI-LVDS SIGNAL SPECIFICATIONS

< Table 16 Timing Table >

Symbol	Parameter	Min	Typ	Max	Unit
$F_M$	Mini-LVDS Clock frequency	-	-	400	MHz
$F_{MLVMOD}$	Modulating frequency of input clock during SSC	-	-	600	KHz
$F_{MLVDEV}$	Maximum deviation of input clock frequency during SSC	-3	-	+3	%
$V_{IH_{LVDS}}$	Mini-LVDS high input voltage	200	-	-	mV
$V_{IL_{LVDS}}$	Mini-LVDS high input voltage	-	-	-200	mV
$t_{SETUP}$	Data setup time	0.5	-	-	ns
$t_{HOLD}$	Data hold time	0.5	-	-	ns

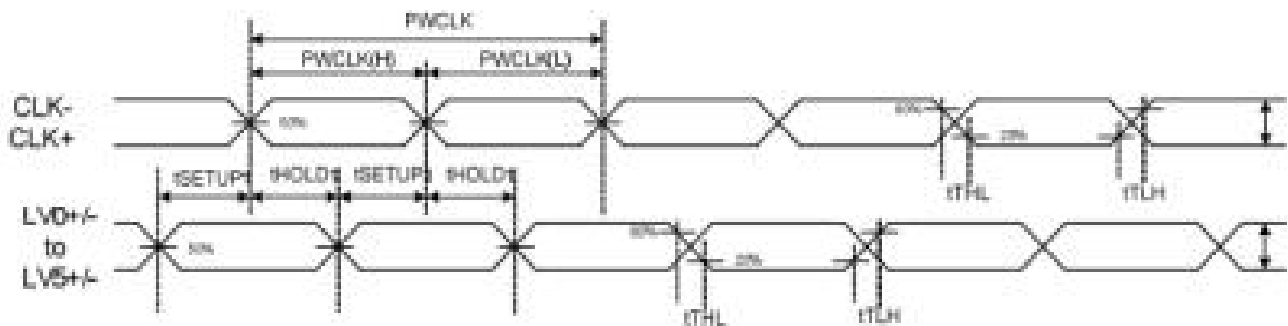
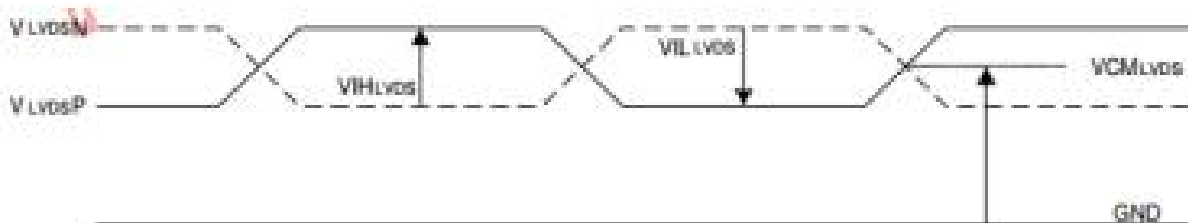

## 4.0 OPTICAL CHARACTERISTICS

### 4.1 Test Conditions

Item	Symbol	Value	Unit
Ambient Temperature	Ta	25±2	°C
Ambient Humidity	Ha	50±10	%RH
Supply Voltage	V <sub>CC</sub>	-	V
Input Signal	According to typical value in "3. ELECTRICAL CHARACTERISTICS"		
Lightbar Current	I <sub>L</sub>	240	mA
Light bar operation voltage	V	49.5	V

### 4.2 OPTICAL SPECIFICATIONS

The relative measurement methods of optical characteristics are shown as below. The following items should be measured under the test conditions described in 4.1 and stable environment shown in Note (5).

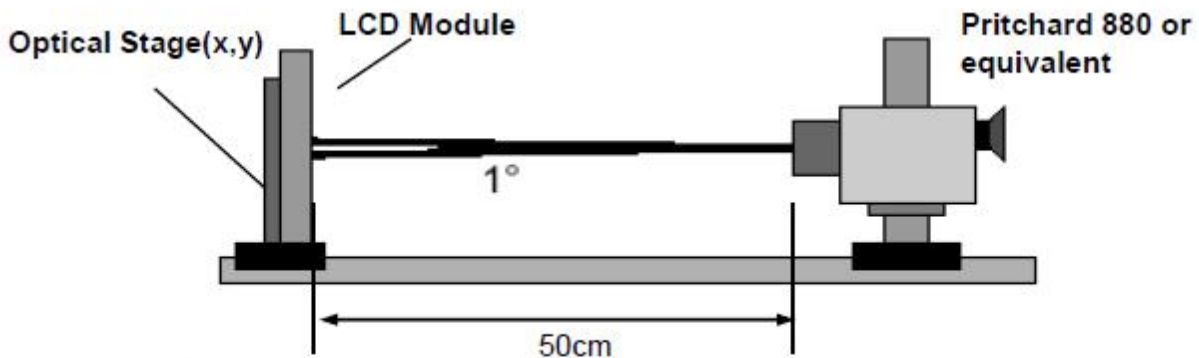

FIG. 1 Optical Characteristic Measurement Equipment and Method

< Table 17 Optical Specifications >

Item		Symbol		Condition	Min.	Typ.	Max.	Unit	Note				
Contrast Ratio		CR			900	1200	—	—	(2)				
Response Time		Gray to gray			—	8	10	ms	(3)				
Center Luminance of White		$L_c$			350	400			(4)				
White Variation		$\delta W$				-	1.38	-	(6)				
Color Chromaticity	Red	Rx		$\theta_x=0^\circ$ , $\theta_y=0^\circ$ Viewing Angle at Normal Direction	Typ. -0.03	0.630	Typ. +0.03	—	(5)				
		Ry				0.344							
	Green	Gx				0.302							
		Gy				0.642							
	Blue	Bx				0.153							
		By				0.046							
	White	Wx				0.280							
		Wy				0.290							
	Color Gamut	CG								72	—	%	NTSC Ratio
	Viewing Angle	2D (CR>10)	Horizontal			$\theta_3$				CR≥10		89	—
$\theta_9$					89	—							
Vertical			$\theta_{12}$		89	—							
			$\theta_6$		89	—							

Note (1) Definition of Contrast Ratio (CR):

The contrast ratio can be calculated by the following expression.

$$\text{Contrast Ratio (CR)} = L_{255} / L_0$$

L255: Luminance of gray level 255

L 0: Luminance of gray level 0

CR = CR (5), where CR (X) is corresponding to the Contrast Ratio of the point X at the figure in note(6)

Note (2)

Definition of Gray-to-Gray Switching Time (VA Model) :

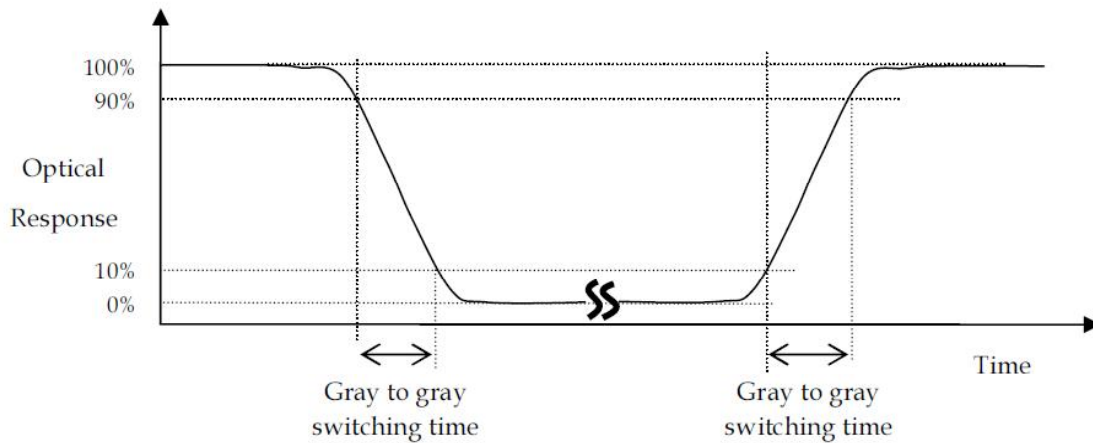

The driving signal means the signal of gray level 0, 31, 63, 95, 127, 159, 191, 223 and 255.

Gray to gray average time means the average switching time of gray level 0, 31, 63, 95, 127, 159, 191, 223 and 255 to each other.

Note (3) Definition of Luminance of White ( $L_C$ ):

Measure the luminance of gray level 255 at center point and 9 points  
 $L_C = L(5)$ , where  $L(X)$  is corresponding to the luminance of the point X at the figure in Note (6)

Note (4) Definition of White Variation ( $\delta W$ ) :

Measure the luminance of gray level 255 at 9 points  
 $\delta W = \text{Maximum}(L_{on1}, L_{on2}, \dots, L_{on9}) / \text{Minimum}(L_{on1}, L_{on2}, \dots, L_{on9})$

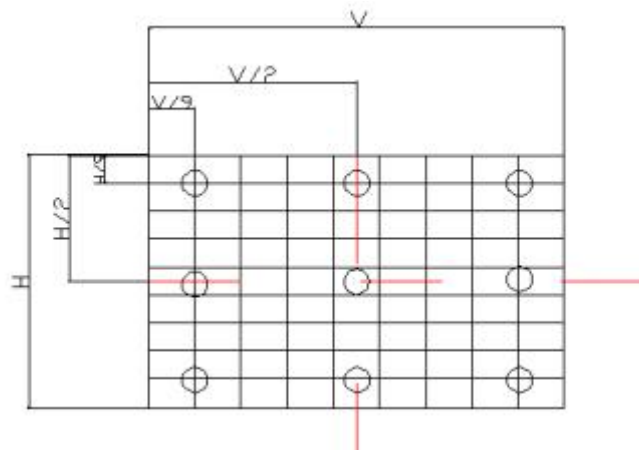



**Note (5) Measurement Setup:**

The LCD module should be stabilized at given temperature for 30 minutes to avoid abrupt temperature change during measuring. In order to stabilize the luminance, the measurement should be executed after lighting Backlight for 30 minutes in a windless room.

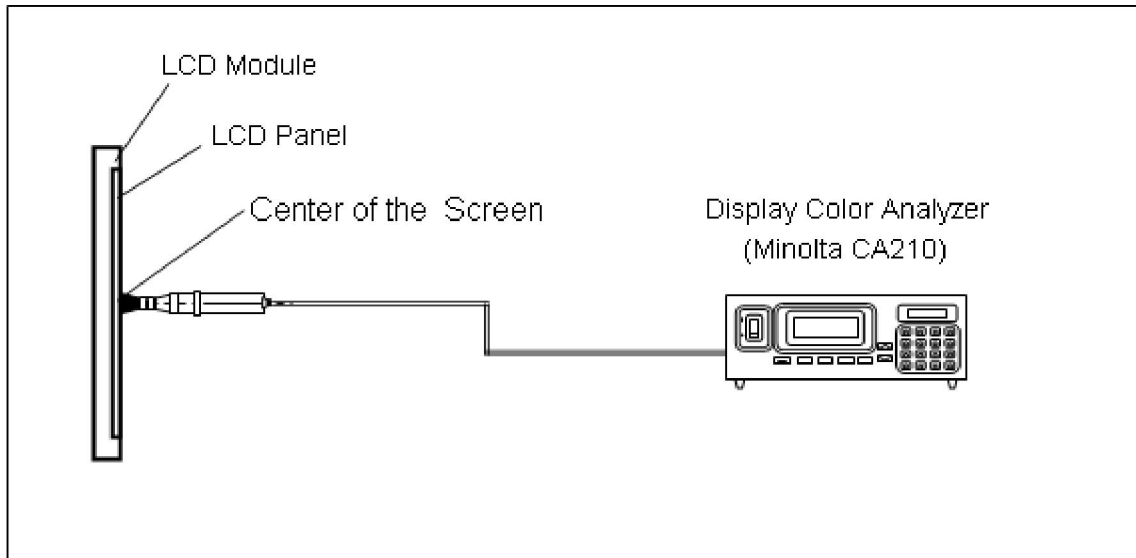

**Note (6) Definition of Viewing Angle ( $\theta_x$ ,  $\theta_y$ ):**

Viewing angle are measured by CS-2000.

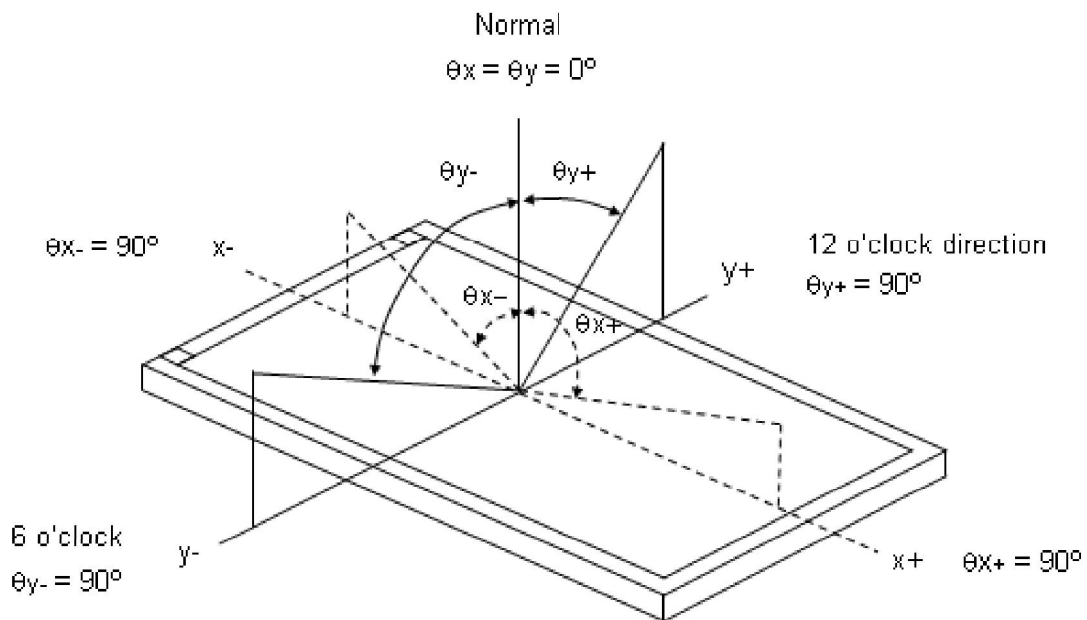

## 5.0 MECHANICAL SPECIFICATIONS

### 5.1 Dimensional Requirements

Figure 1 (located in Appendix) shows mechanical outlines for the model DV320FHM-NN0. Other parameters are shown in Table 18.

< Table 18. Dimensional Parameters >

Parameter	Specification	Unit
Active area	698.4 (H) × 392.85(V)	mm
Pixel pitch	121.25 (H) × 363.75 (V)	μm
Number of pixels	1920(H) × 1080(V) (1 pixel = R + G + B dots)	pixels
Weight	850	gram

### 5.2 Semi-Glare and Polarizer Hardness

The surface of the LCD has an Anti-glare coating to minimize reflection and a coating to Reduce scratching.

## 6.0 RELIABILITY

The Reliability test items and its conditions are shown in below.

< Table 19. Reliability Test Parameters >

No	Test Items	Conditions
1	High temperature & high humidity storage test	Ta = 60 °C, 90%RH, 240 hrs
2	Low temperature storage test	Ta = -20 °C, 240 hrs
3	High temperature & high humidity operation test	Ta = 50 °C, 80%RH, 240hrs
4	Low temperature operation test	Ta = 0 °C, 240hrs
5	Thermal shock test	Ta = -20 °C ↔ 60 °C (0.5 hr), 100 cycle
6	On/off test	On/Off:10sec(on) / 5sec(off), 30000 times
7	Altitude Test (non-operating)	40000ft -10 °C /24hrs ,25°C /24hrs, -10 °C /24hrs
8	Vibration test (non-operating)	Frequency : 10 ~ 300 Hz, Random Gravity / AMP : 1.0 Grms Period : X, Y, Z 30 min/axis
9	Shock test (non-operating)	Gravity : 50G Pulse width : 11msec, Sine wave ± X, ± Y, ± Z Once for each direction
10	Electro-static discharge test	Air : ± 15kV ,150pF/330Ω ,100Point ,1time/Point Contact : ± 8kV ,150pF/330Ω ,100Point ,1time/Point Non operation Contact: ± 4KV~ ± 6KV,150pF/330Ω,100Point, Input connector Pin, 3 times/pin with no function loss

# BOE

PRODUCT GROUP  
TFT-LCD

REV  
A

ISSUE DATE  
2019.7.11

## 7.0 PRODCUT SERIAL NUMBER

DP/N	DV320FHM-NN0	B4	   MADE IN CHINA
XXXXXX			
XXXX	XXXXXXXXXXXXXXXXXXXX		
	REV A00		
XX-XXXXXX-XXXXX-XXX-XXXX			

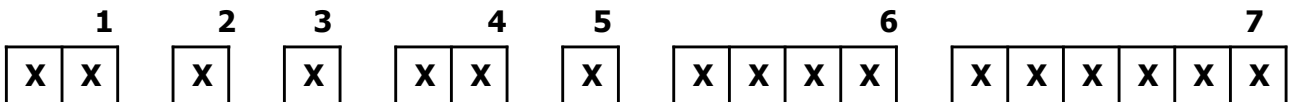

- 1. Control Number
- 2. Rank / Grade
- 3. Line Classification
- 4. Year (2011 : 11, 2012 : 12, ...)

- 5. Month (1,2,3, ... , 9, X, Y, Z)
- 6. Internal Use
- 7. Serial Number

SPEC. NUMBER S8-64-8A-130	SPEC. TITLE DV320FHM-NN0 Product Specification Rev.A	PAGE 25 OF 36
------------------------------	---	------------------

## 8.0 PACKING INFORMATION

BOE provides the standard shipping container for customers, unless customer specifies their packing information. The standard packing method and Barcode information are shown in below.

### 8.1 Packing Specifications

- (1) 6LCD TV modules / 1 Box
- (2) Box dimensions: 820(L) x375(W) x520(H)mm
- (3) Weight: approximately 36Kg (6 modules per box)

### 8.2 Packing Method

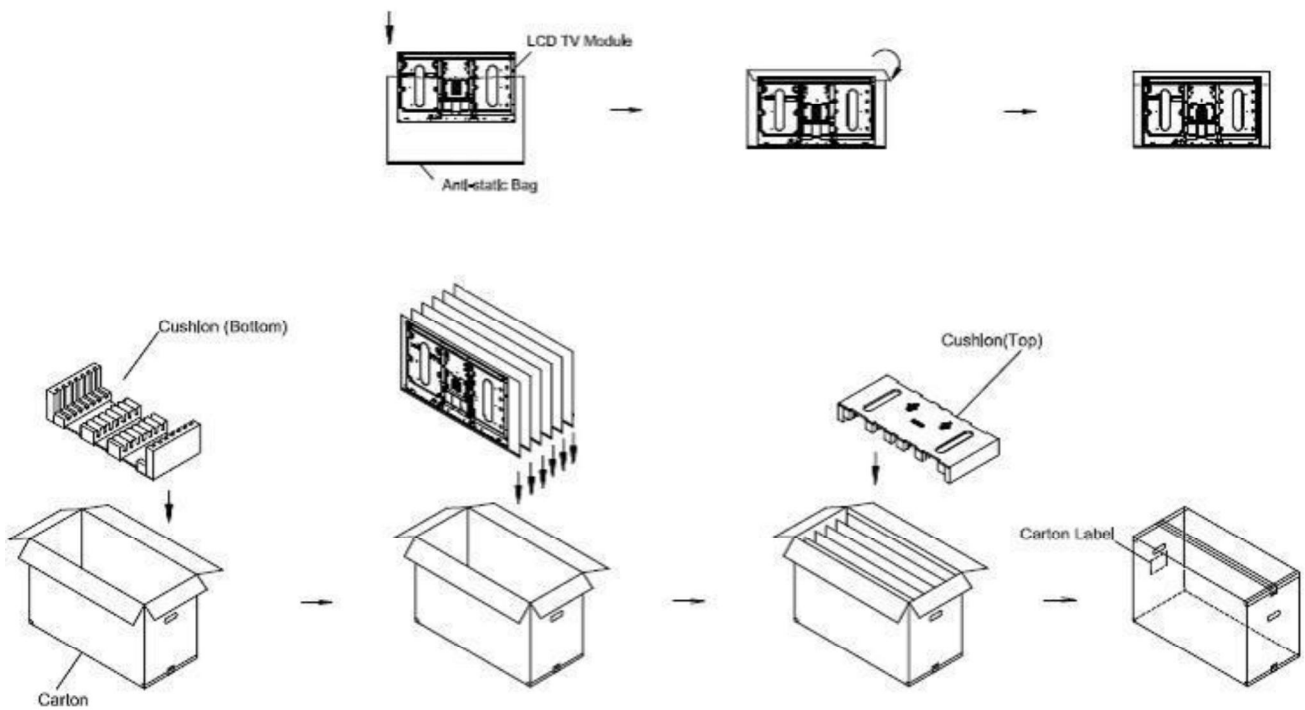

Sea / Land Transportation  
(40ft Container)

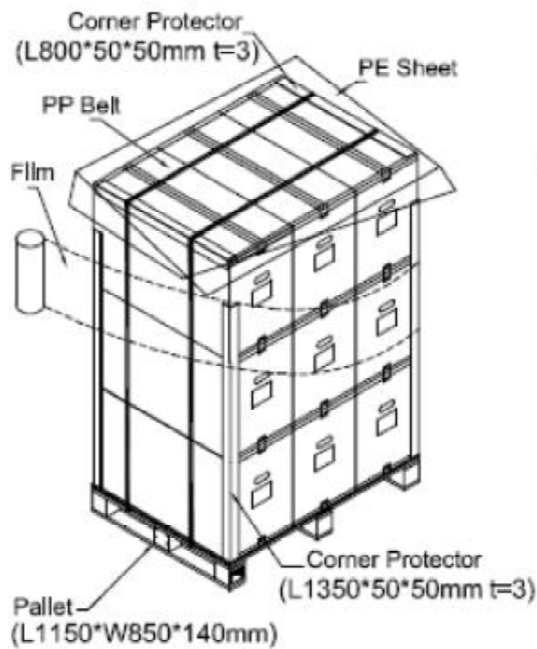

Sea / Land Transportation  
(40ft HQ Container)

Air Transportation

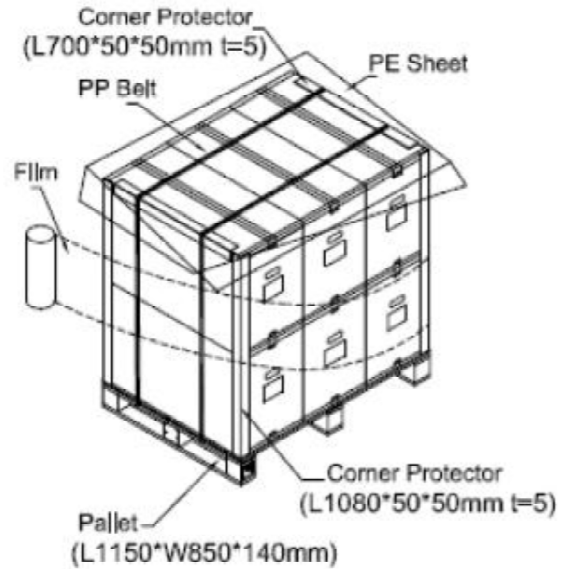
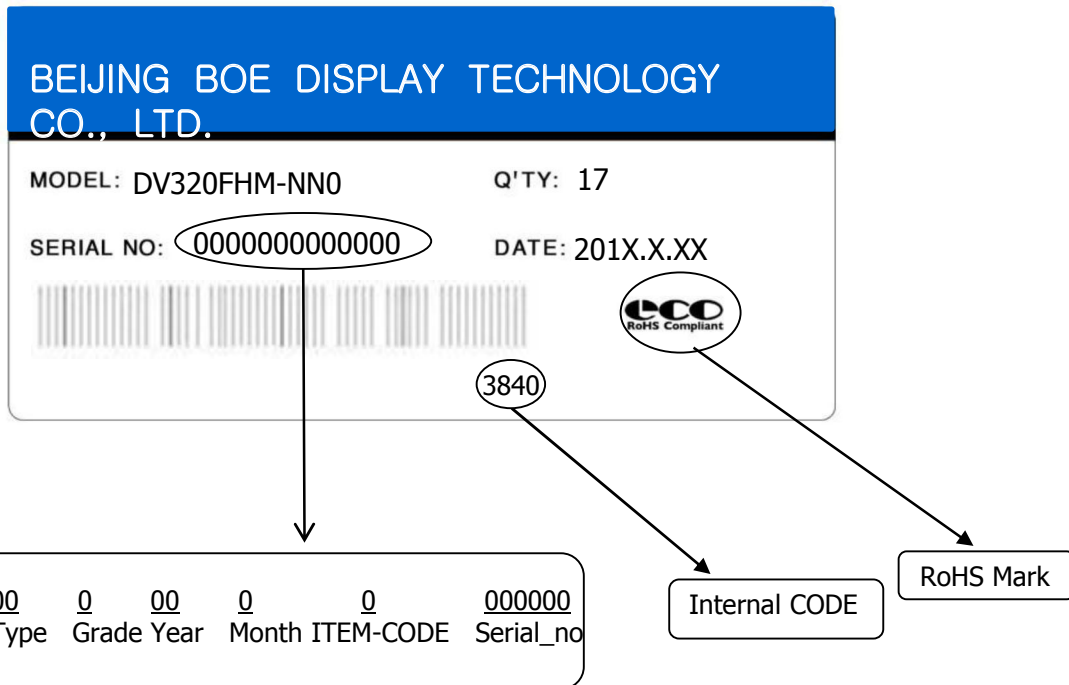

Figure. 9-2 Packing method

### 8.3 Box Label

- Label Size : 110 mm (L) × 55 mm (W)
- Contents
  - Model : DV320FHM-NN0
  - Q`ty : 6Pcs
  - Serial No. : Box Serial No. See next page for detail description.
  - Date : Packing Date
  - FG Code : FG Code of Product



SPEC. NUMBER S8-64-8A-130	SPEC. TITLE DV320FHM-NN0 Product Specification Rev.A	PAGE 28 OF 36
------------------------------	---	------------------



<b>BOE</b>	PRODUCT GROUP	REV	ISSUE DATE
	TFT-LCD	A	2019.7.11

## 9.0 HANDING & CAUTIONS

Please pay attention to the followings when you use this TFT LCD Module.

### 9.1 Mounting Precautions

- Use finger-stalls with soft gloves in order to keep display clean during the incoming inspection and assembly process.
- You must mount a module using specified mounting holes (Details refer to the drawings)
- You should consider the mounting structure so that uneven force (ex. Twisted stress, Concentrated stress) is not applied to the module. And the case on which a module is mounted should have sufficient strength so that external force is not transmitted directly to the module.
- Do not apply mechanical stress or static pressure on module; Abnormal display cause by pressing some parts of module during assembly process, do not belong to product failure, the press should be agreed by two sides.
- Determine the optimum mounting angle, refer to the viewing angle range in the specification for each model.
- Do not apply mechanical stress or static pressure on module, and avoid impact, vibration and falling.
- Acetic acid type and chlorine type materials for the cover case are not desirable because the former generates corrosive gas of attacking the polarizer at high temperature and the latter causes circuit break by electro-chemical reaction.
- Protection film for polarizer on the module should be slowly peeled off before display.
- Be careful to prevent water & chemicals contact the module surface.
- You should adopt radiation structure to satisfy the temperature specification.
- Do not touch, push or rub the exposed polarizers with glass, tweezers or anything harder than HB pencil lead. And please do not rub with dust clothes with chemical treatment. Do not touch the surface of polarizer for bare hand or greasy cloth. (Some cosmetics are detrimental to the polarizer.)
- When the surface becomes dusty, please wipe gently with absorbent cotton or other soft materials like chamois soaks with petroleum benzine. Normal-hexane & alcohol is recommended for cleaning the adhesives used to attach front / rear polarizers. Do not use acetone, toluene, because they cause chemical damage to the polarizer.
- Wipe off saliva or water drops as soon as possible. Their long time contact with polarizer causes deformations and color fading..

SPEC. NUMBER S8-64-8A-130	SPEC. TITLE DV320FHM-NN0 Product Specification Rev.A	PAGE 29 OF 36
------------------------------	---	------------------

<b>BOE</b>	PRODUCT GROUP	REV	ISSUE DATE
	TFT-LCD	A	2019.7.11

- This module has its circuitry PCB's on the rear side and Driver IC, should be handled carefully in order not to be stressed.
- Avoid impose stress on PCB and Driver IC during assembly process ,Do not drawing, bending, COF package & wire
- Do not disassemble the module.

## 9.2 Operating Precautions

- Do not connector or disconnect the cable to/from the Module at the "Power On" Condition.
- When the module is operating, do not lose CLK, ENAB signals. If any one of these signals is lost, the module would be damaged.
- Obey the supply voltage sequence. If wrong sequence is applied, the module would be damaged.
- Do not allow to adjust the adjustable resistance or switch
- The electrochemical reaction caused by DC voltage will lead to LCD module degradation, so DC drive should be avoided.
- The LCD modules use C-MOS LSI drivers, so customers are recommended that any unused input terminal would be connected to Vdd or Vss, do not input any signals before power is turn on, and ground you body, work/assembly area, assembly equipment to protect against static electricity.
- Do not exceed the absolute maximum rating value. (supply voltage variation, input voltage variation, variation in part contents and environmental temperature, and so on) Otherwise the Module may be damaged.
- Module has high frequency circuits. Sufficient suppression to the electromagnetic interference shall be done by system manufacturers. Grounding and shielding methods may be important to minimized the interference.
- Design the length of cable to connect between the connector for back-light and the converter as shorter as possible and the shorter cable shall be connected directly , The long cable between back-light and Converter may cause the Luminance of LED to lower and need a higher startup voltage
- The cables should be as short as possible between System Board and PCB interface.
- Connectors are precision devices to transmit electrical signals, and operators should plug in parallel
- Be careful for condensation at sudden temperature change. Condensation makes damage to polarizer or electrical contacted parts. And after fading condensation, smear or spot will occur.

SPEC. NUMBER S8-64-8A-130	SPEC. TITLE DV320FHM-NN0 Product Specification Rev.A	PAGE 30 OF 36
------------------------------	---	------------------

### 9.3 Electrostatic Discharge Precautions

- Avoid the use work clothing made of synthetic fibers. We recommend cotton clothing or other conductivity-treated fibers.
- Since a module is composed of electronic circuits, it is not strong to electrostatic discharge. Make certain that treatment persons are connected to ground through wrist band etc.
- Do not close to static electricity to avoid product damage.
- Do not touch interface pin directly.

### 9.4 Precautions for Strong Light Exposure

- Do not leave the module operation or storage in Strong light . Strong light exposure causes degradation of polarizer and color filter.

### 9.5 Precautions for Storage

#### A. Atmosphere Requirement

ITEM	UNIT	MIN	MAX
Storage Temperature	(°C)	5	40
Storage Humidity	(%rH)	40	75
Storage Life	6 months		
Storage Condition	<ul style="list-style-type: none"> <li>• The storage room should be equipped with a dark and good ventilation facility.</li> <li>• Prevent products from being exposed to the direct sunlight, moisture and water.</li> <li>• The product need to keep away from organic solvent and corrosive gas.</li> <li>• Be careful for condensation at sudden temperature change.</li> <li>• Storage condition is guaranteed under packing conditions.</li> </ul>		

#### B. Package Requirement

- The product should be placed in a sealed polythene bag.
- Product Should be placed on the pallet, Which is away from the floor, Be cautions not to pile the product up.
- The polarizer surface should not come in contact with any other object. It is recommended that they be stored in the container in which they were shipped.
- As the original protective film, do not use the adhesive protective film to avoid change of Pol color and characteristic.

<b>BOE</b>	PRODUCT GROUP	REV	ISSUE DATE
	TFT-LCD	A	2019.7.11

## 9.6 Precautions for protection film

- Remove the protective film slowly, keeping the removing direction approximate 30-degree not vertical from panel surface, If possible, under ESD control device like ion blower, and the humidity of working room should be kept over 50%RH to reduce the risk of static charge.
- People who peeled off the protection film should wear anti-static strap and grounded well.

## 9.7 Appropriate Condition for Commercial Display

-Generally large-sized LCD modules are designed for consumer applications . Accordingly, long-term display like in Commercial Display application, can cause uneven display including image sticking. To optimize module's lifetime and function, several operating usages are required.

### 1. Normal operating condition

- Temperature:  $20 \pm 15^{\circ}\text{C}$
- Operating Ambient Humidity :  $55 \pm 20\%$
- Display pattern: dynamic pattern (Real display)
- Well-ventilated place is recommended to set up Commercial Display system

### 2. Special operating condition

#### a. Ambient condition

- Well-ventilated place is recommended to set up Commercial Display system.

#### b. Power and screen save

- Periodical power-off or screen save is needed after long-term display.

c. As the low temperature, the response time is greatly delayed. As the high temperatures (higher than the operating temperature) the LCD module may turn black screen. The above phenomenon cannot explain the failure of the display. When the temperature returns to the normal operating temperature, the LCD module will return to normal display.

d. When expose to drastic fluctuation of temperature (hot to cold or cold to hot) ,the LCD module may be affected; Specifically, drastic temperature fluctuation from cold to hot ,produces dew on the LCD module 's surface which may affect the operation of the polarizer and LCD module

e. Do not exceed the absolute maximum rating value. (supply voltage variation, input voltage variation, variation in part contents and environmental temperature, and so on) Otherwise the Module may be damaged.

f. Products exposed to low temperature environment for a long time, need to carry out necessary protection , low temperature environment is usually refrigerators , vending machine Etc...

g. Long time and large angle forward use or unconventional use , It is strongly recommended to contact BOE for filed application engineering advice

SPEC. NUMBER S8-64-8A-130	SPEC. TITLE DV320FHM-NN0 Product Specification Rev.A	PAGE 32 OF 36
------------------------------	---	------------------

f. Product reliability and functions are only guaranteed when the product is used under right operation usages. If product will be used in extreme conditions such as high temperature, high humidity, high altitude, special display images, running time, long time operation, outdoor operation, etc. It is strongly recommended to contact BOE for filed application engineering advice. Otherwise, its reliability and function may not be guaranteed. Extreme conditions are commonly found at airports, transit stations, banks, stock market and controlling systems.

3. Operating usages to protect against image sticking due to long-term static display.

a. Suitable operating time: under 20 hours a day.

b. Static information display recommended to use with moving image.

- Cycling display between 5 minutes' information(static) display and 10 seconds' moving image.

c. Background and character (image) color change

- Use different colors for background and character, respectively.

- Change colors themselves periodically.

d. Avoid combination of background and character with large different luminance.

1) Abnormal condition just means conditions except normal condition.

2) Black image or moving image is strongly recommended as a screen save

4. Lifetime in this spec. is guaranteed only when Commercial Display is used according to operating usages.

5. Module should be turned clockwise based on front view when used in portrait mode.

- Landscape Mode

The default placement is TCON side on the lower side and the image is shown upright via viewing from the front.

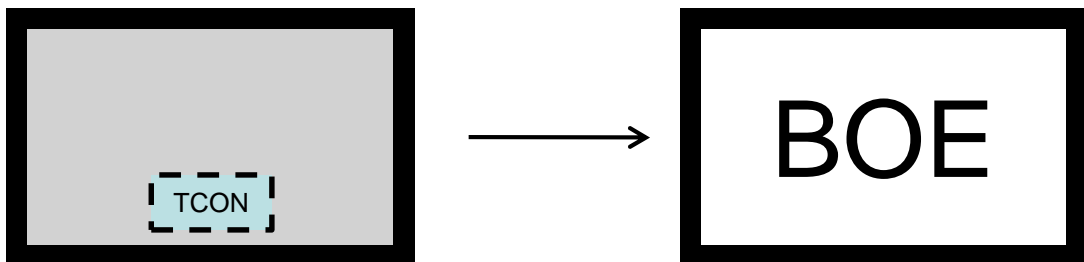

<b>BOE</b>	PRODUCT GROUP	REV	ISSUE DATE
	TFT-LCD	A	2019.7.11

- Portrait Mode

The default placement is that TCON side has to be placed on the left side via viewing from the front

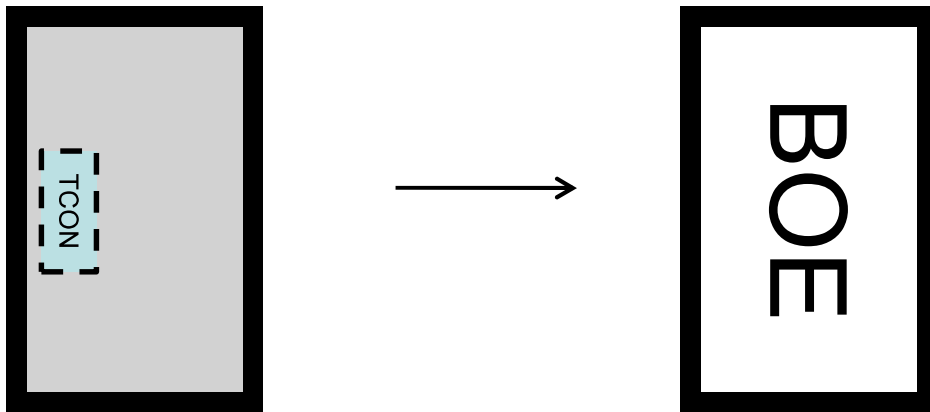

## 9.8 Other Precautions

### A. LC Leak

- If the liquid crystal material leaks from the panel, it is recommended to wash the LC with acetone or ethanol and then burn it.
- If the liquid crystal material leaks from the panel, it should be kept away from the eyes or mouth. In case of contact with hands, skin or clothes, it has to be washed away thoroughly with soap.
- If LC in mouth, mouth need to be washed, drink plenty of water to induce vomiting and follow medical advice.
- If LC touch eyes, eyes need to be washed with running water at least 15 minutes.

### B. Rework

- When returning the module for repair or etc., Please pack the module not to be broken. We recommend to use the original shipping packages.

SPEC. NUMBER S8-64-8A-130	SPEC. TITLE DV320FHM-NN0 Product Specification Rev.A	PAGE 34 OF 36
------------------------------	---	------------------

## 10.0 APPENDIX

TFT-LCD Module Outline Dimensions(Front View)

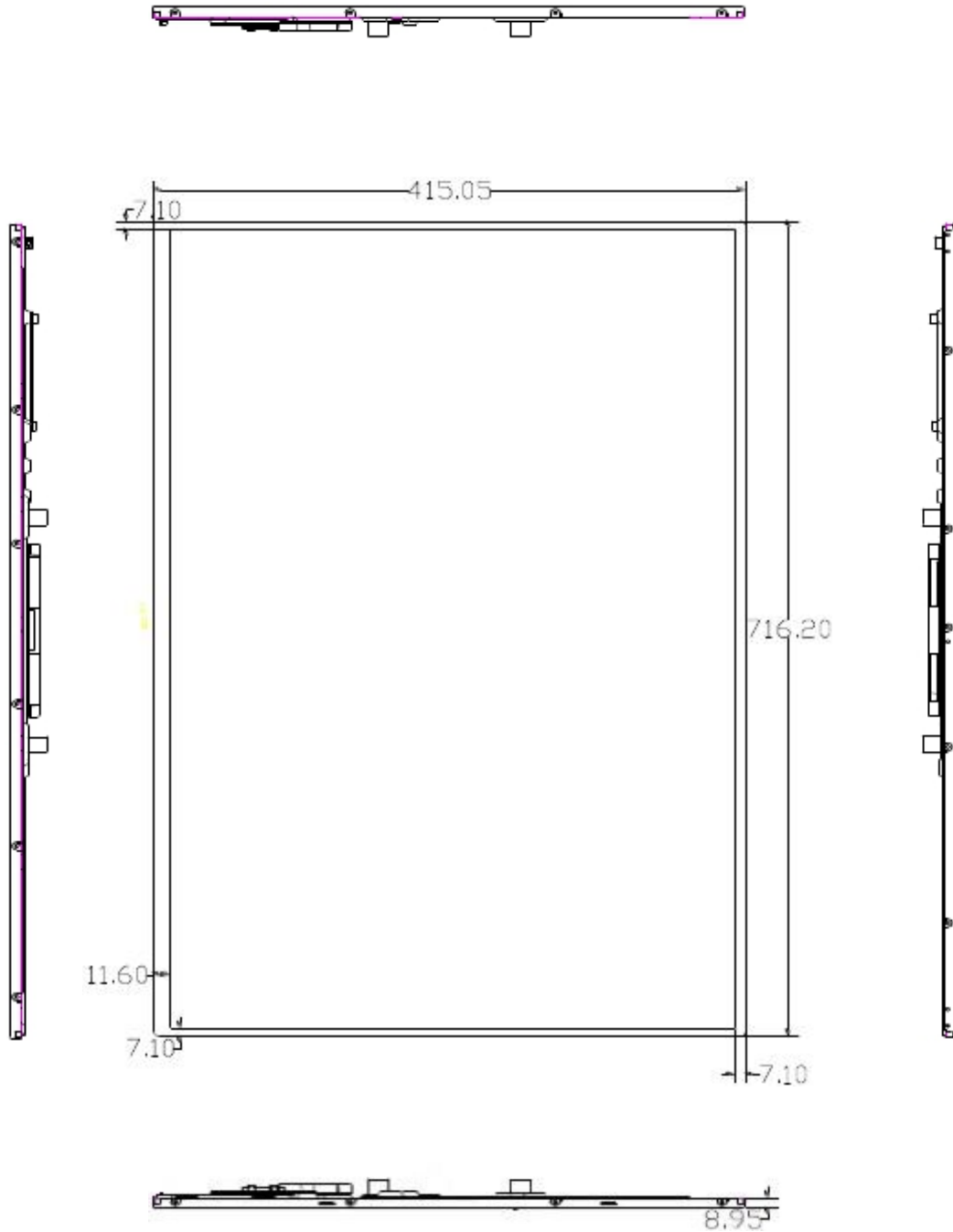



TFT-LCD Module Outline Dimensions(RearView) mm

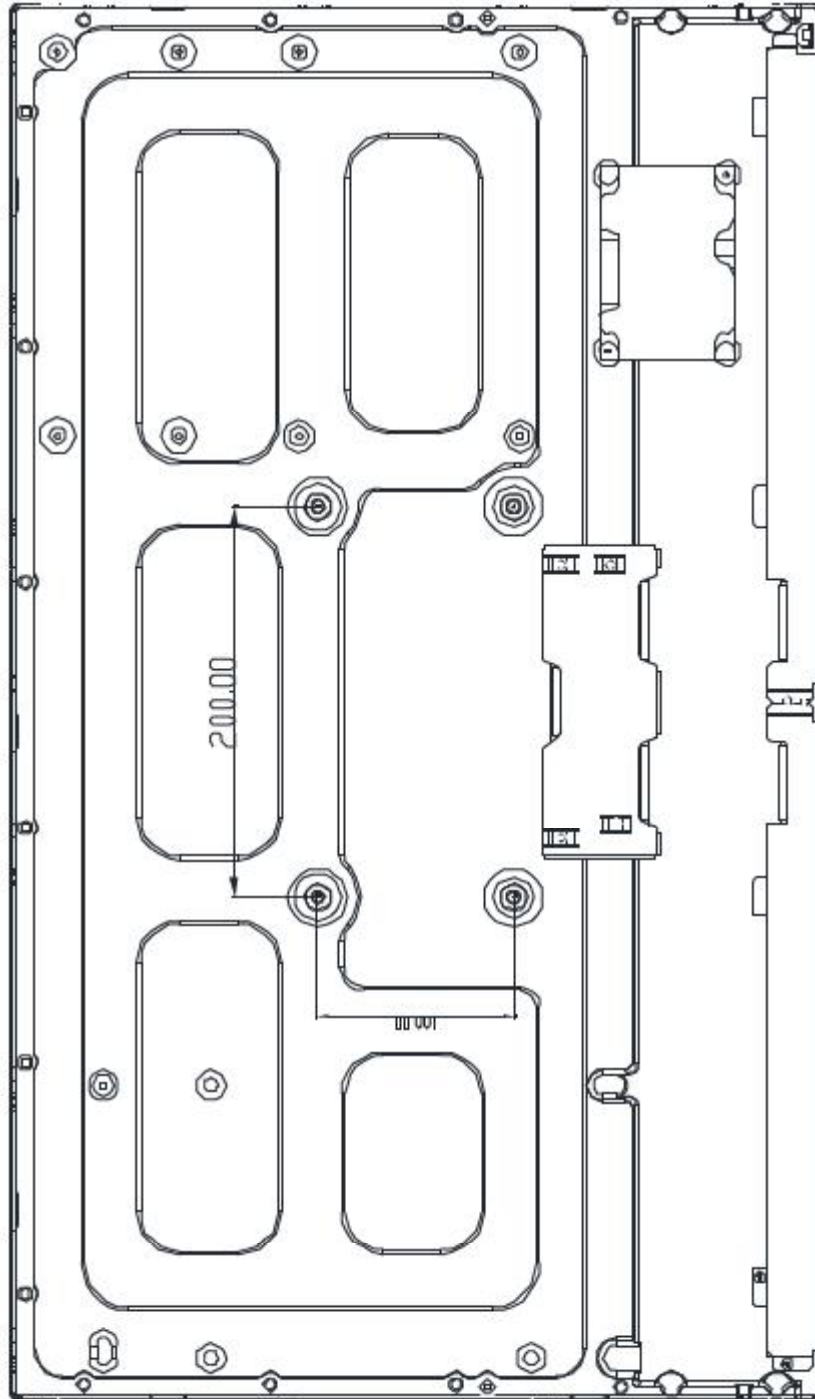

# DATA MODUL



ALL TECHNOLOGIES. ALL COMPETENCIES. ONE SPECIALIST.



DATA MODUL AG  
Landsberger Straße 322  
DE-80687 Munich  
Phone: +49-89-56017-0

DATA MODUL WEIKERSHEIM GMBH  
Lindenstraße 8  
DE-97990 Weikersheim  
Phone: +49-7934-101-0



More information and worldwide locations can be found at

[www.data-modul.com](http://www.data-modul.com)