



SPECIFICATION



ED060KC1

6.0"

Version: 2.0

Date: 13.08.2014

Note: This specification is subject to change without prior notice

www.data-modul.com

Version: 2.0

TECHNICAL SPECIFICATION

MODEL NO: ED060KC1

The content of this information is subject to be changed without notice.
Please contact E Ink or its agent for further information.

Customer's Confirmation

Customer _____

Date _____

By _____

E Ink's Confirmation

Approve By 陳金洪

Confirmed By 傅淑貞

Prepared By 官靜璇

Revision History

Rev.	Issued Date	Revised Contents
1.0	May , 27,2014	NEW
2.0	Aug , 13 , 2014	Delete page 9 Digital voltage supply 2 range (VDD2)

TECHNICAL SPECIFICATION

CONTENTS

<i>NO.</i>	<i>ITEM</i>	<i>PAGE</i>
-	Cover	1
-	Revision History	2
-	Contents	3
1	General Description	4
2	Features	4
3	Mechanical Specifications	4
4	Mechanical Drawing of EPD module	5
5	Input/Output Terminals	7
6	Electrical Characteristics	9
7	Power on Sequence	15
8	Refresh Rate	17
9	Optical Characteristics	18
10	Handling, Safety and Environment Requirements And Remark	20
11	Reliability test	22
12	Bar Code definition	23
13	Border definition	24
14	Block Diagram	25
15	Packing	26

1. General Description

ED060KC1 is a reflective electrophoretic E Ink® technology display module based on active matrix TFT substrate. It has 6" active area with 1072 x 1448 pixels, the display is capable to display images at 2-16 gray levels (1-4 bits) depending on the display controller and the associated waveform file it used.

2. Features

- Carta High contrast reflective/electrophoretic technology
- 1072 x 1448 display
- Ultra wide viewing angle
- Ultra low power consumption
- Pure reflective mode
- Bi-stable
- Commercial temperature range
- Landscape, portrait mode

3. Mechanical Specifications

Parameter	Specifications	Unit	Remark
Screen Size	6.0 (3:4 diagonal)	Inch	
Display Resolution	1072 (H)×1448(V)	Pixel	
Active Area	90.584 (H)×122.356 (V)	mm	
Pixel Pitch	0.0845 (H)×0.0845 (V)	mm	
Pixel Configuration	Square		
Outline Dimension	101.8(W)*138.4(H)*1.01(D)	mm	
Module Weight	28 ±2.8	g	
Number of Gray	16 Gray Level (monochrome)		
Display operating mode	Reflective mode		

4. Mechanical Drawing of EPD Module

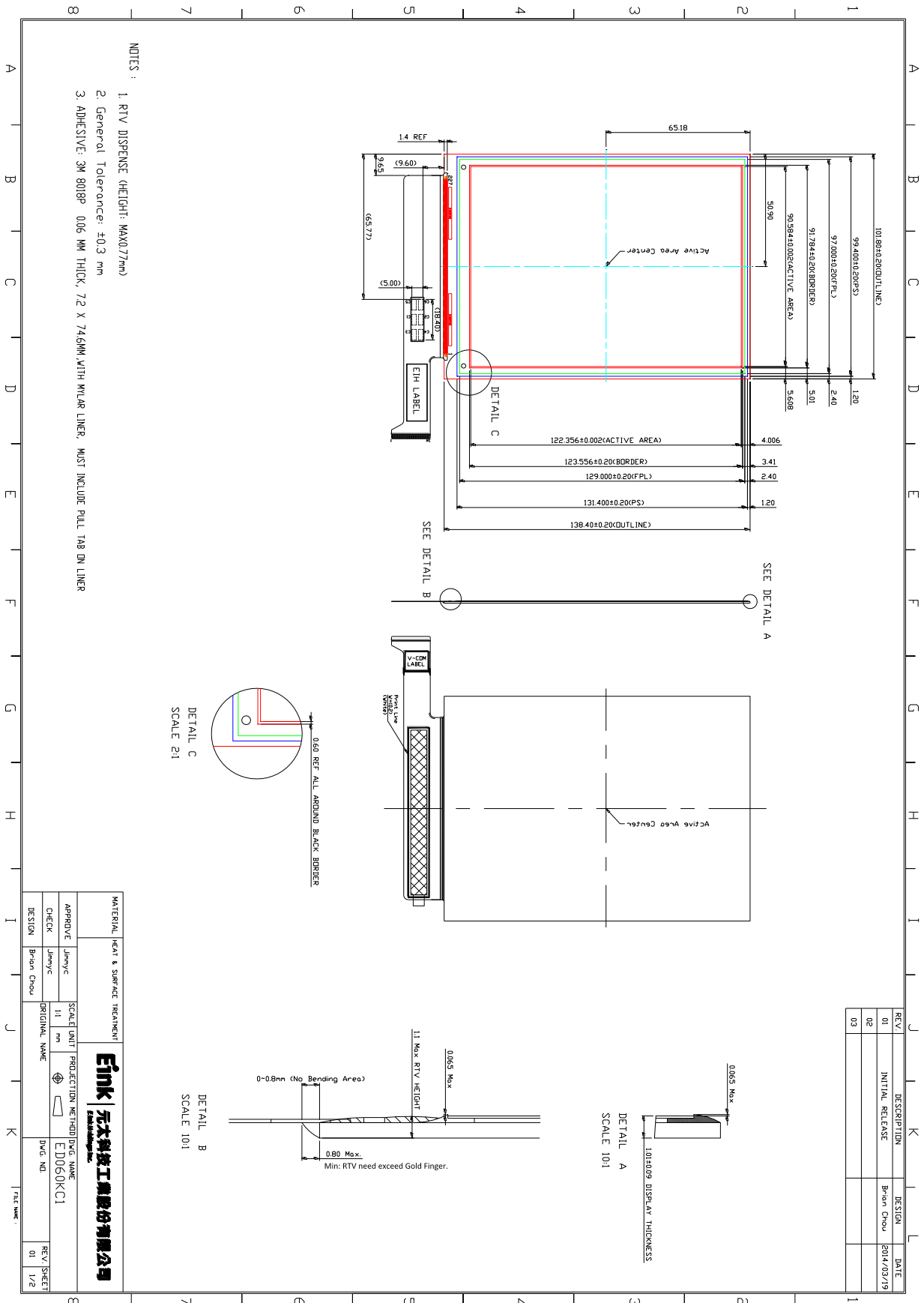

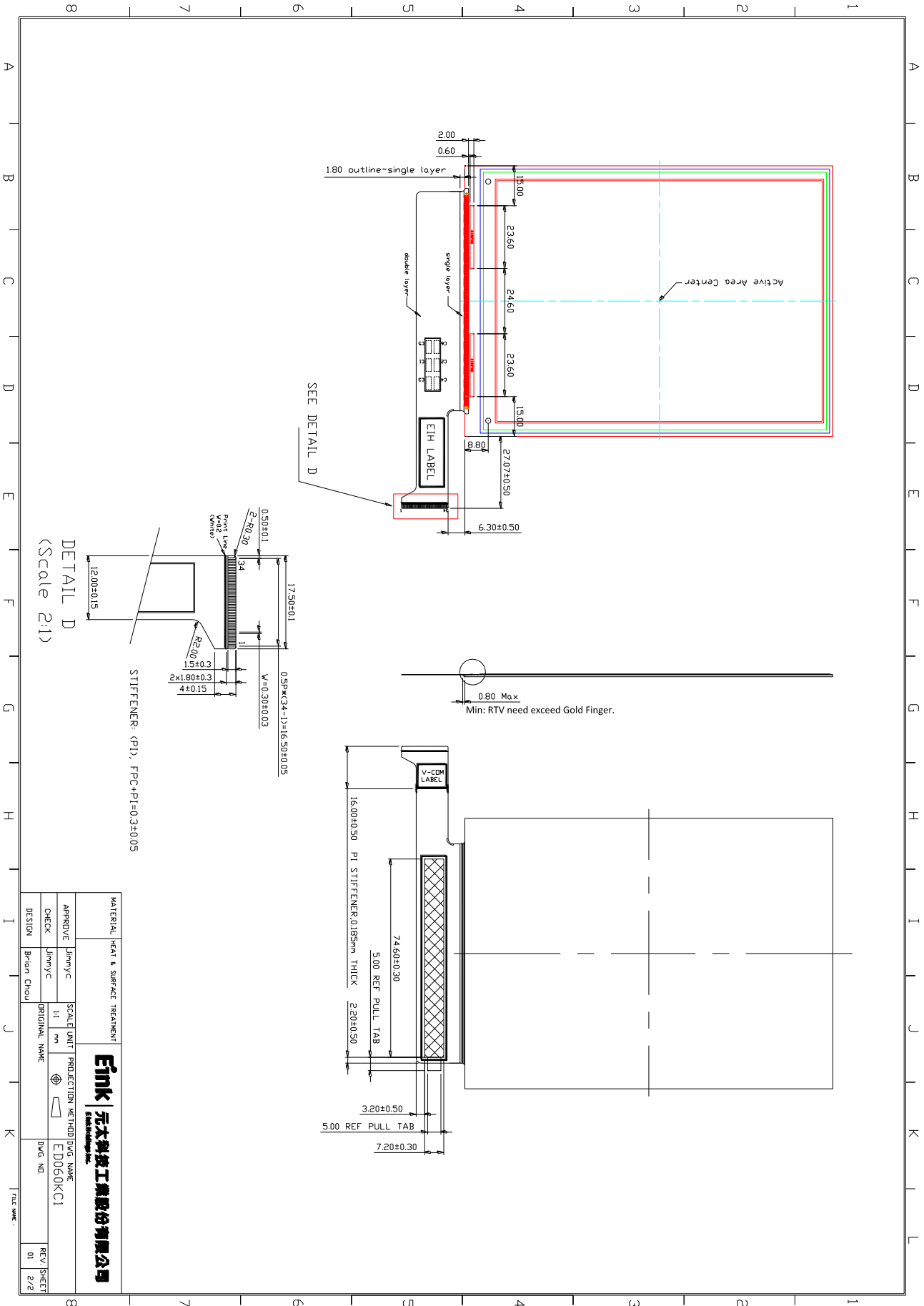

MATERIAL		HEAT & SURFACE TREATMENT		E Ink 元太科技工業股份有限公司	
APPROVE	Jimmy C	SCALE UNIT	mm	PROJECTION METHOD	DWG. NAME
CHECK	Jimmy C	1:1	mm		ED060KC1
DESIGN	Bharan Choud	ORIGINAL NAME		DWG. NO.	
					REV./SHEET
					01 / 2/2

5. Input/Output Interface

5-1) Connector type: FH34S-34S-0.5SH(50)-Hirose

Pin Assignment

Pin #	Signal	Description	Remark
1	VNEG	Negative power supply source driver	
2	VEE	Negative power supply gate driver	
3	VSS	Ground	
4	NC	NC	
5	NC	NC	
6	VDD	Digital power supply drivers (1.8V)	
7	VSS	Ground	
8	XCL	Clock source driver	
9	VSS	Ground	
10	XLE	Latch enable source driver	
11	XOE	Output enable source driver	
12	XSTL	Start pulse source driver	
13	D0	Data signal source driver	
14	D1	Data signal source driver	
15	D2	Data signal source driver	
16	D3	Data signal source driver	
17	D4	Data signal source driver	
18	D5	Data signal source driver	
19	D6	Data signal source driver	
20	D7	Data signal source driver	
21	VCOM	Common connection	
22	NC	NC	
23	NC	NC	
24	NC	NC	
25	NC	NC	
26	VSS	Ground	
27	MODE 1	Output mode selection gate driver	
28	CKV	Clock gate driver	
29	SPV	Start pulse gate driver	
30	NC	NC	
31	Border	Border connection	
32	VSS	Ground	
33	VPOS	Positive power supply source driver	
34	VGG	Positive power supply gate driver	

5-2) Panel Scan direction

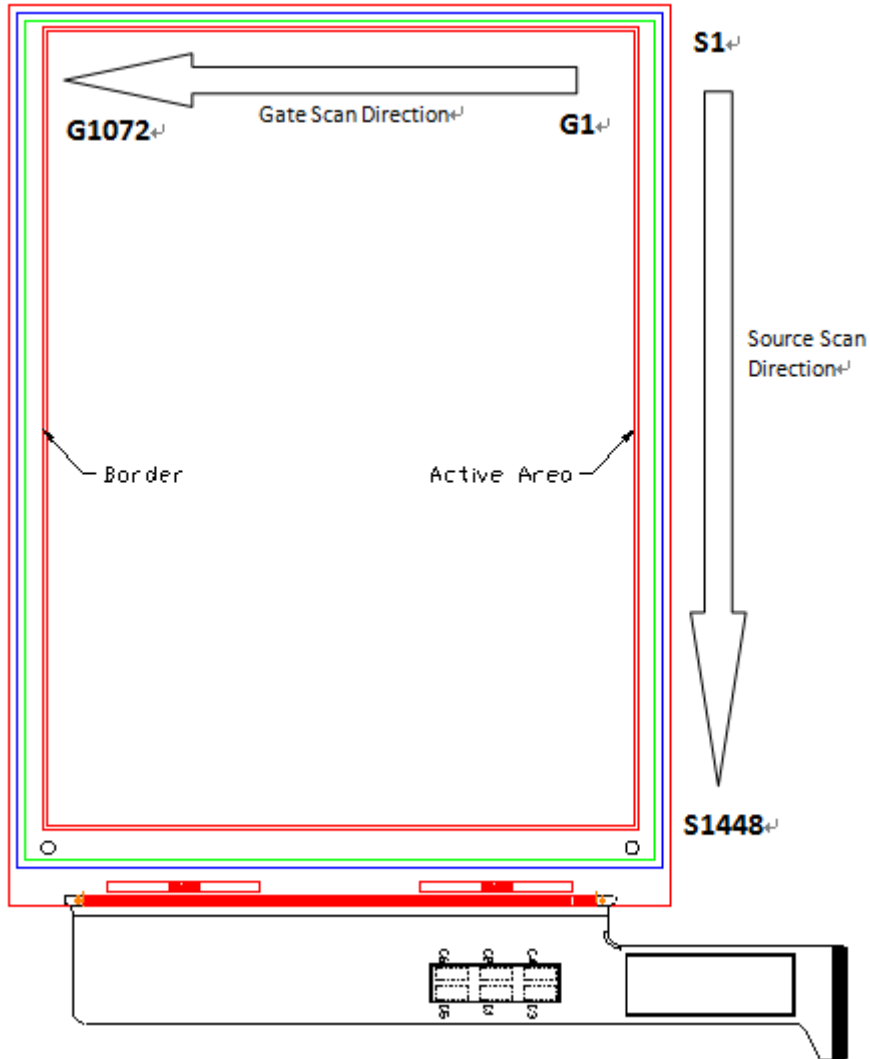

6. Electrical Characteristics

6-1) Absolute Maximum Ratings:

Parameter	Symbol	Rating	Unit	Remark
Logic Supply Voltage	VDD	-0.3 to +7	V	--
Positive Supply Voltage	V _{POS}	-0.3 to +18	V	--
Negative Supply Voltage	V _{NEG}	+0.3 to -18	V	--
Max .Drive Voltage Range	V _{POS} - V _{NEG}	36	V	--
Supply Voltage	VGG	-0.3 to +45	V	--
Supply Voltage	VEE	-25.0 to +0.3	V	--
Supply Range	VGG-VEE	-0.3 to +45	V	--
Operating Temp. Range	TOTR	0 to +50	°C	--
Storage Temperature	TSTG	-25 to +70	°C	--

6-2) Panel DC characteristics

Parameter	Symbol	Conditions	Min	Typ	Max	Unit
Signal ground	V _{SS}		-	0	-	V
Logic Voltage supply	VDD		1.7	1.8	2.1	V
	I _{VDD}	V _{DD} =1.8V	-	3.5	8.3	mA
Gate Negative supply	V _{EE}		-21	-20	-19	V
	I _{EE}	V _{EE} = -20V	-	1.2	12	mA
Gate Positive supply	V _{GG}		24	25	26	V
	I _{GG}	V _{GG} = 25V	-	1.2	2.5	mA
Source Negative supply	V _{NEG}		-15.4	-15	-14.6	V
	I _{NEG}	V _{NEG} = -15V	-	8.5	160	mA
Source Positive supply	V _{POS}		14.6	15	15.4	V
	I _{POS}	V _{POS} = 15V	-	8.2	166	mA
Border supply	V _{COM}		-3.5	Adjusted	-1.5	V
Asymmetry source	V _{Asym}	V _{POS} +V _{NEG}	-800	0	800	mV
Common voltage	V _{COM}		-3.5	Adjusted	-1.5	V
	I _{COM}		-	0.2	-	mA
Panel Power	P		-	315	5200	mW
Standby power panel	P _{STBY}		-	-	0.01	mW

- The maximum power consumption is measured using 85Hz waveform with following pattern transition: from pattern of repeated 1 consecutive black scan lines followed by 1 consecutive white scan line to that of repeated 1 consecutive white scan lines followed by 1 consecutive black scan lines. (Note 6-1)
- The Typical power consumption is measured using 85Hz waveform with following pattern transition: from horizontal 4 gray scale pattern to vertical 4 gray scale pattern. (Note 6-2)
- The standby power is the consumed power when the panel controller is in standby mode.
- The listed electrical/optical characteristics are only guaranteed under the controller & waveform provided by E Ink.
- Vcom is recommended to be set in the range of assigned value $\pm 0.1V$
- The maximum I_{COM} inrush current is about 1000 mA

Note 6-1

The maximum power consumption

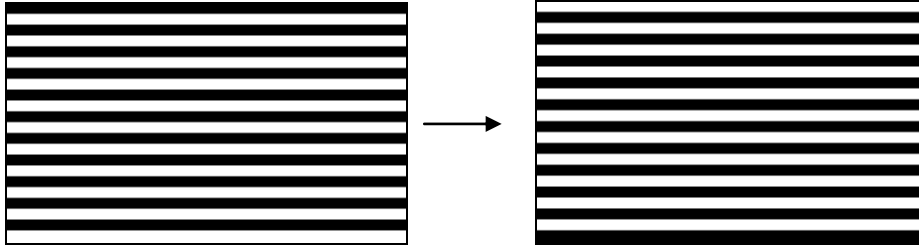

Note6-2

The Typical power consumption

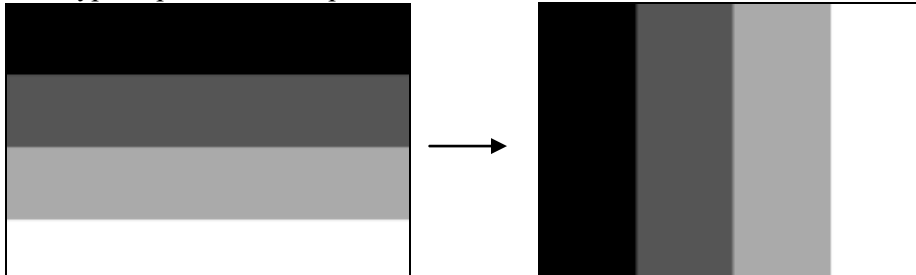

6-3)Panel AC characteristics

VDD=1.7V to 2.1V, unless otherwise specified.

Parameter	Symbol	Min.	Typ.	Max.	Unit
Clock frequency	fckv	-	-	200	kHz
Minimum “L” clock pulse width	twL	1	-	-	us
Minimum “H” clock pulse width	twH	1	-	-	us
Clock rise time	trckv	-	-	100	ns
Clock fall time	tfckv	-	-	100	ns
SPV setup time	tSU	100	-	twH-100	ns
SPV hold time	tH	100	-	twH-100	ns
Pulse rise time	trspv	-	-	100	ns
Pulse fall time	tfspv	-	-	100	ns
Clock XCL cycle time	tcy	22.22	-	-	ns
D0 .. D7 setup time	tsu	11	-	-	ns
D0 .. D7 hold time	th	11	-	-	ns
XSTL setup time	tstls	0.5* tcy	-	0.8* tcy	ns
XSTL hold time	tstlh	0.5* tcy	-	180*tcy-tstls	ns
XLE on delay time	tLEdly	4.5* tcy	-	-	ns
XLE high-level pulse width (When VDD=1.7V to 2.1V)	tLEw	400	-	-	ns
XLE off delay time	tLEoff	250	-	-	ns
Output setting time to +/- 30mV(C _{load} =200pF)	tout	-	-	20	us

OUTPUT LATCH CONTROL SIGNALS

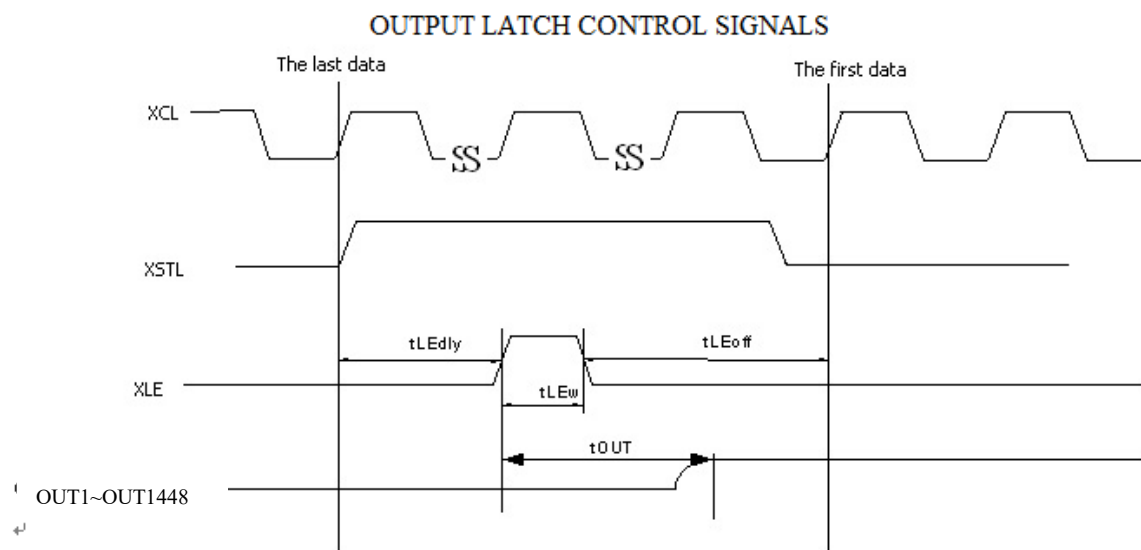

CLOCK & DATA TIMING

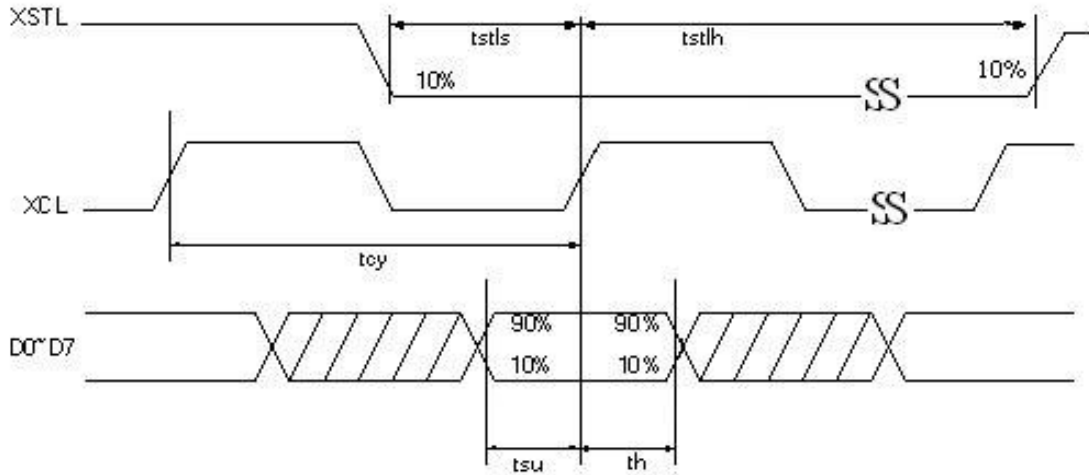

CKV & SPV TIMING

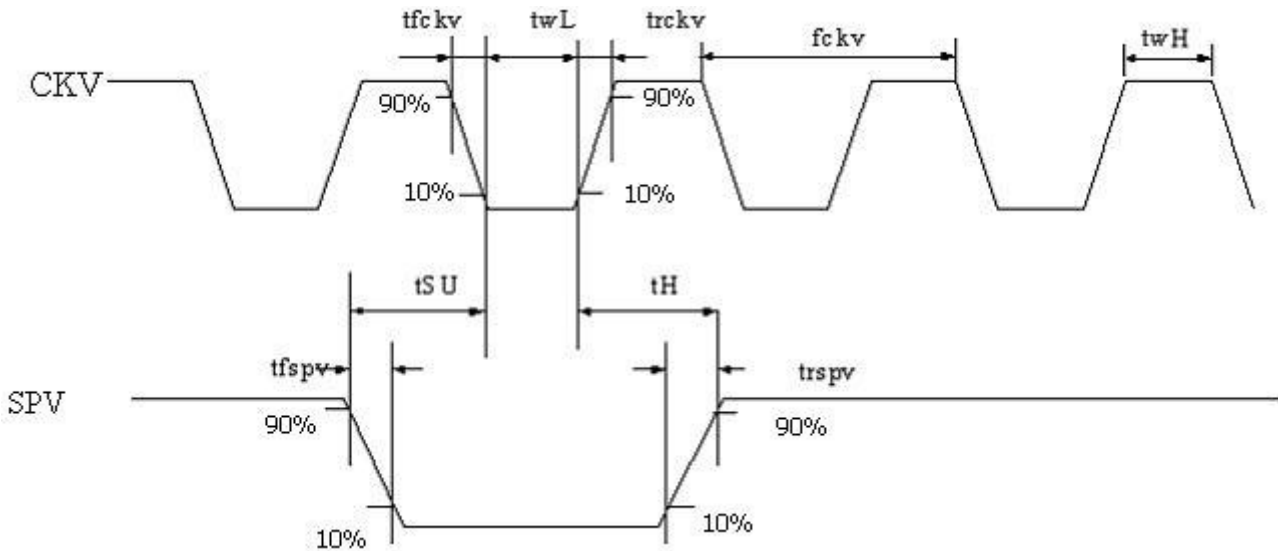

GATE OUTPUT TIMING

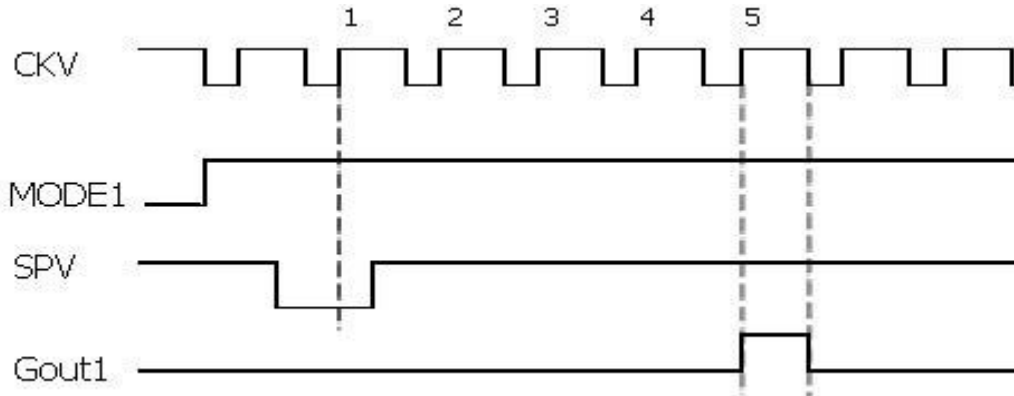

Note : First gate line on timing
After 5CKV , gate line is on .

6-4) Controller Timing

This timing mode is depicted on Figure 1 and Figure 2 and it refers to timing of Source Driver Output Enable (SDOE) and Gate Driver Clock (GDCK). Note, that in this mode LGON follows GDCK timing.

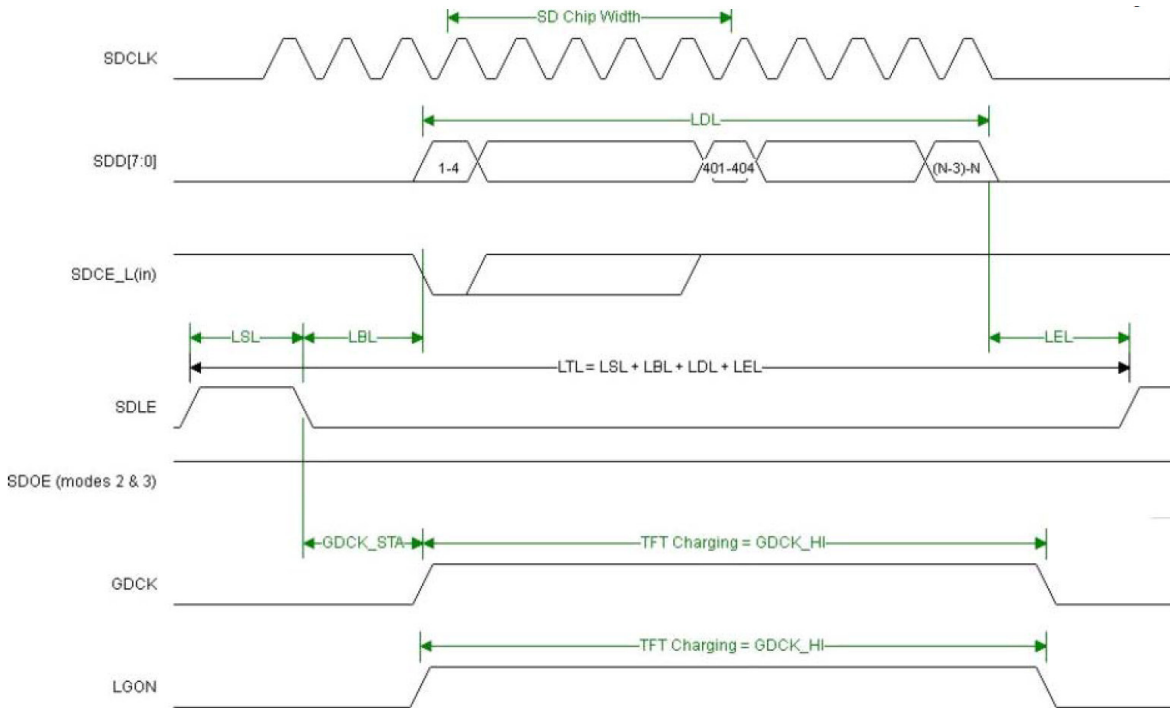

Figure 1 Line Timing in Mode 3

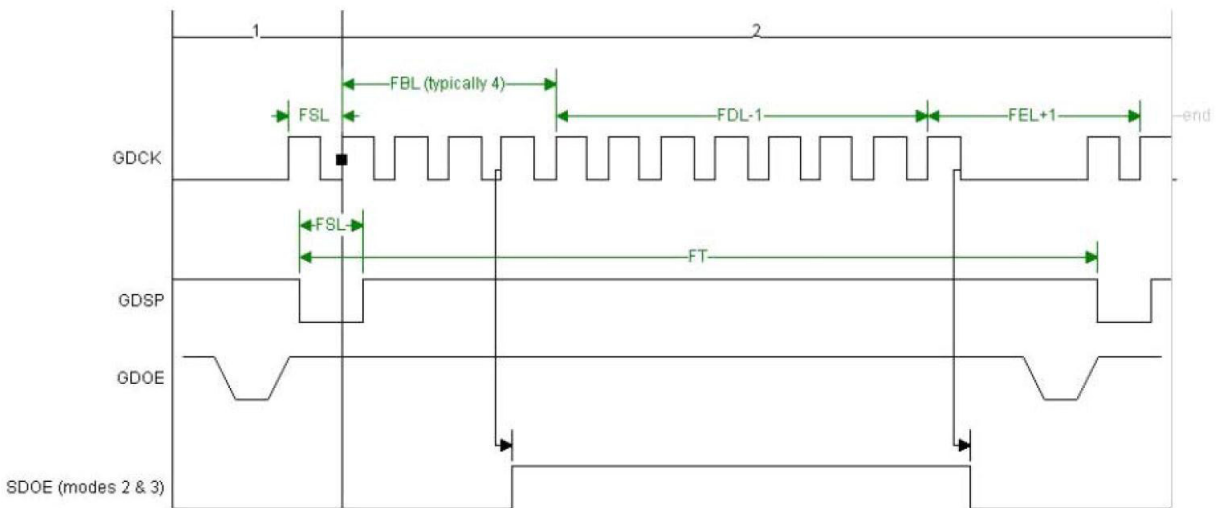

Figure 2 Frame Timing in Mode 3

Table Timing Parameters Table

Mode	3	Resolution 1072*1448				
SDCK 【MHz】	40					
Pixels Per SDCK	4					
Line Parameters 【SDCK】	LSL	LBL	LDL	LEL	GDCK_STA	LGONL
	14	8	362	51	100	281
Line Parameters 【us】	-	-	-	-	-	-
	0.35	0.20	9.05	1.28	2.5	7.03
Frame Parameters 【lines】	FSL	FBL	FDL	FEL	-	FR 【Hz】
	2	4	1072	4	-	84.99
Frame Parameters 【us】					-	-
	21.75	43.5	11658	43.5	-	-

Note 1 : For parameters definition , see Section 6. Active Matrix Electronic Paper Display Timings

Note 2 : For Isis Controller GDCK_STA and LGONL are not settable parameters ; GDCK_STA=LBL, LGONL=LDL+0.5

Note 3 : For Freescale SoC GDOE Low pulse represent FSL and GDSP pulses with the first period of FBL

7. Power on Sequence

Power Rails must be sequenced in the following order :

1. VSS → VDD → VNEG → VPOS (Source driver) → VCOM
2. VSS → VDD → VEE → VGG (Gate driver)

POWER ON

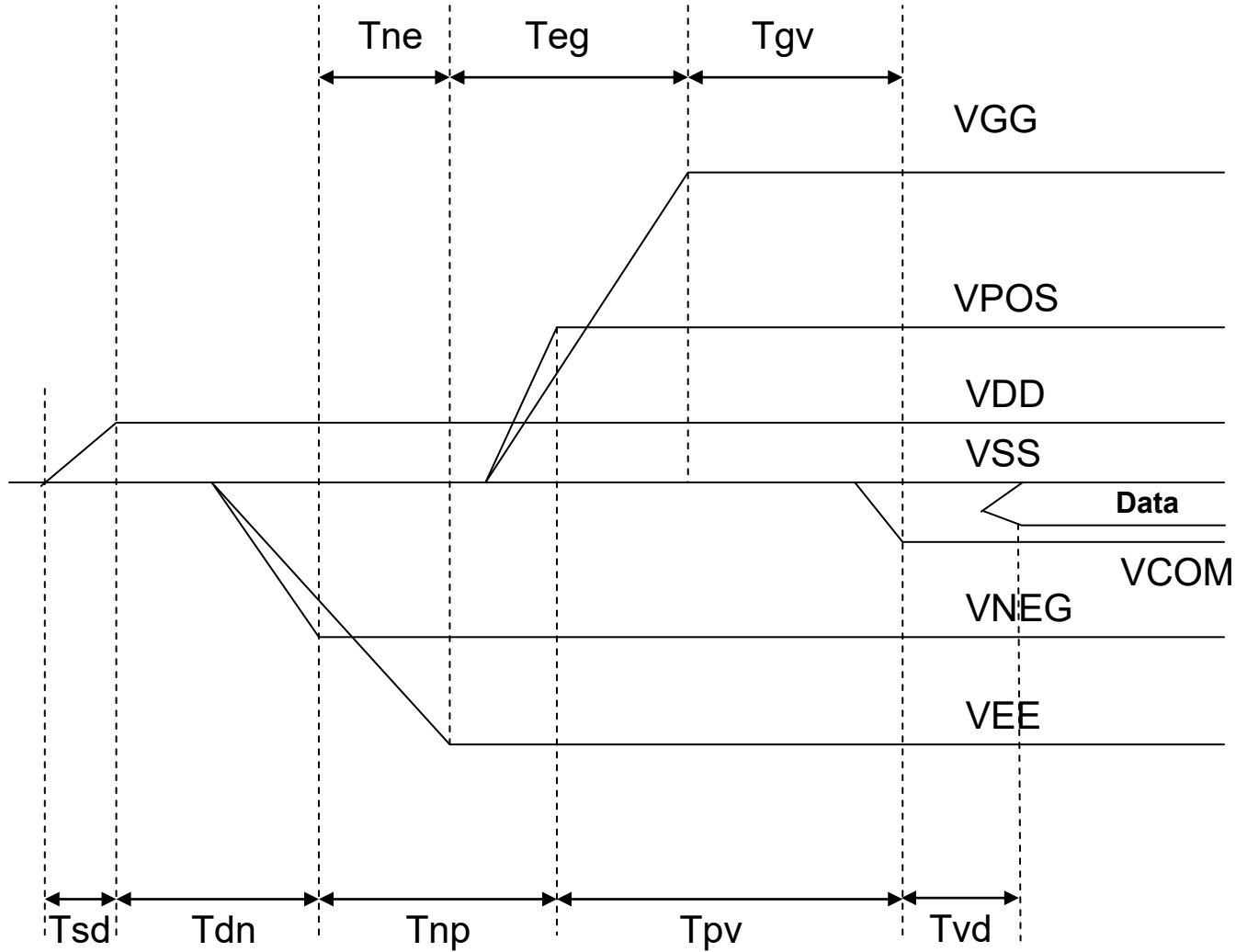

	Min	Max
Tsd	30us	-
Tdn	100us	-
Tnp	1000us	-
Tpv	100us	-
Tvd	100us	-
Tne	0us	-
Teg	1000us	-
Tgv	100us	-

POWER DOWN

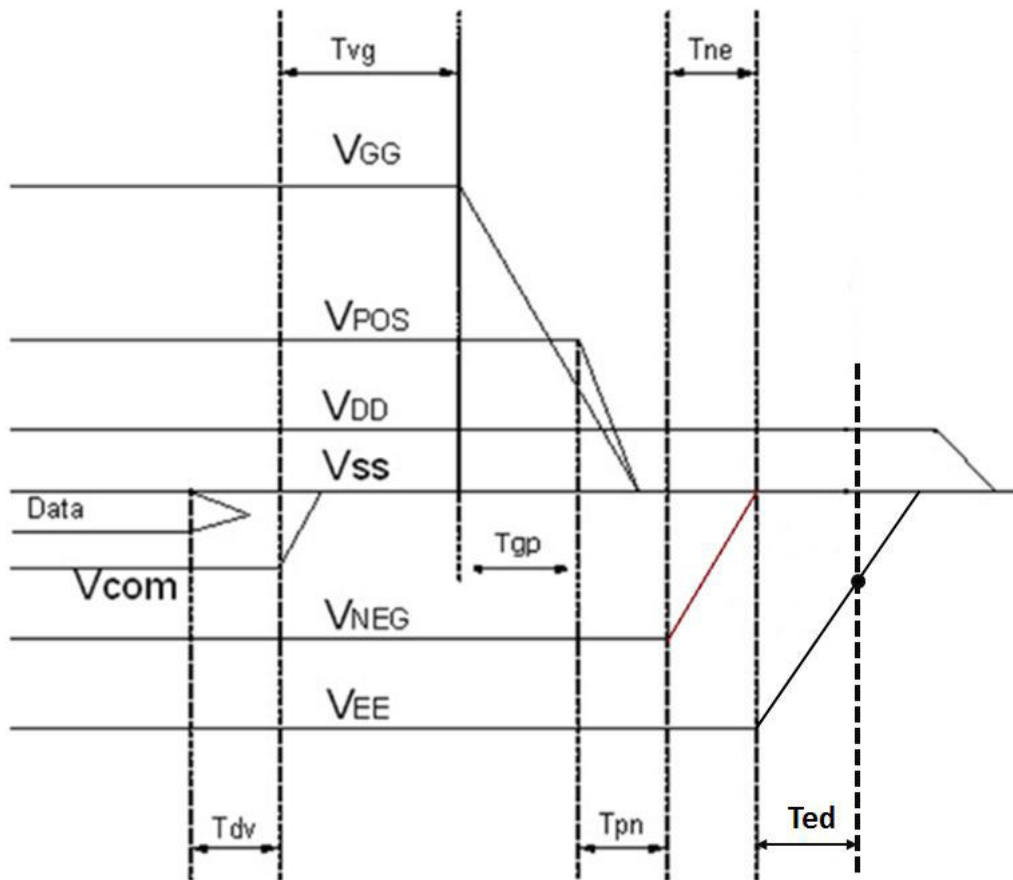

	Min	Max	Remark
Tdv	100μs	-	
Tvg	0μs	-	
Tgp	0μs	-	
Tpn	0μs	-	
Tne	0μs	-	
Ted	0.5s	-	Discharged point @ -7.4 Volt

Note1 : Supply voltages decay through pull-down resistors.

Note2 : Begin to turn off VEE power after VNEG and VPOS are completely or almost discharged to GND state.

Note3 : VEE must remain negative of Vcom during decay period

8. Refresh Rate

The module ED060KC1 is applied at a maximum screen refresh rate of 85Hz.

	Min	Max
Refresh Rate	-	85Hz

9. Optical characteristics

9-1) Specifications

Measurements are made with that the illumination is under an angle of 45 degrees, the detector is perpendicular unless otherwise specified.

T = 25°C

Symbol	Parameter	Conditions	Min	Typ.	Max	Unit	Note
R	Reflectance	White	38	46	-	%	Note 9-1
G _n	N _{th} Grey Level	-	-	$DS+(WS-DS) \times n/(m-1)$	-	L*	-
CR	Contrast Ratio	-	12	17	-		-

WS: White state , DS: Dark state, Gray state from Dark to White :DS、G1、G2...、G_n...、G_{m-2}、WS
m:4、8、16 when 2、3、4 bits mode

Note 9-1: Luminance meter: Eye – One Pro Spectrophotometer

9-2) Definition of contrast ratio

The contrast ratio (CR) is the ratio between the reflectance in a full white area (R_l) and the reflectance in a dark area (R_d):

$$CR = R_l/R_d$$

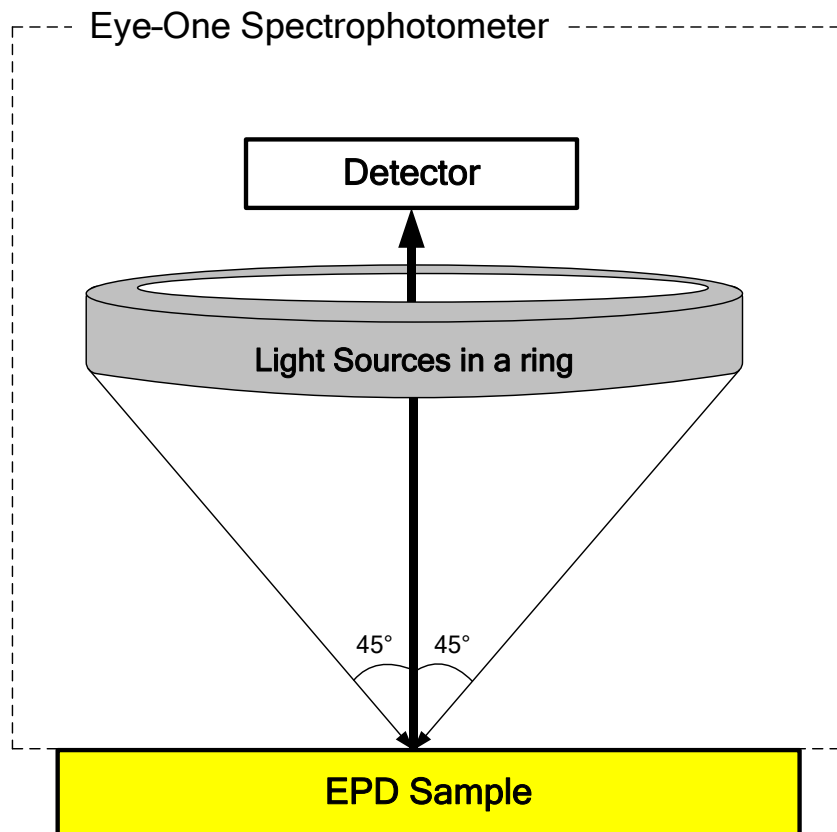

9-3) Reflection Ratio

The reflection ratio is expressed as:

$$R = \text{Reflectance Factor}_{\text{white board}} \times (L_{\text{center}} / L_{\text{white board}})$$

L_{center} is the luminance measured at center in a white area (R=G=B=1). $L_{\text{white board}}$ is the luminance of a standard white board. Both are measured with equivalent illumination source. The viewing angle shall be no more than 2 degrees.

10. HANDLING, SAFETY AND ENVIRONMENTAL REQUIREMENTS AND REMARK

WARNING
The display glass may break when it is dropped or bumped on a hard surface. Handle with care. Should the display break, do not touch the electrophoretic material. In case of contact with electrophoretic material, wash with water and soap.

CAUTION
The display module should not be exposed to harmful gases, such as acid and alkali gases, which corrode electronic components.
Disassembling the display module can cause permanent damage and invalidate the warranty agreements.
IPA solvent can only be applied on active area and the back of a glass. For the rest part, it is not allowed.

Mounting Precautions
(1) It's recommended that you consider the mounting structure so that uneven force (ex. Twisted stress) is not applied to the module.
(2) It's recommended that you attach a transparent protective plate to the surface in order to protect the EPD. Transparent protective plate should have sufficient strength in order to resist external force.
(3) You should adopt radiation structure to satisfy the temperature specification.
(4) Acetic acid type and chlorine type materials for the cover case are not desirable because the former generates corrosive gas of attacking the PS at high temperature and the latter causes circuit break by electro-chemical reaction.
(5) Do not touch, push or rub the exposed PS with glass, tweezers or anything harder than HB pencil lead. And please do not rub with dust clothes with chemical treatment. Do not touch the surface of PS for bare hand or greasy cloth. (Some cosmetics deteriorate the PS)
(6) When the surface becomes dusty, please wipe gently with absorbent cotton or other soft materials like chamois soaks with petroleum benzene. Normal-hexane is recommended for cleaning the adhesives used to attach the PS. Do not use acetone, toluene and alcohol because they cause chemical damage to the PS.
(7) Wipe off saliva or water drops as soon as possible. Their long time contact with PS causes deformations and color fading.

Data sheet status	
Product specification	This data sheet contains formal product specifications.

Data sheet status

Limiting values

Limiting values given are in accordance with the Absolute Maximum Rating System (IEC 134). Stress above one or more of the limiting values may cause permanent damage to the device. These are stress ratings only and operation of the device at these or at any other conditions above those given in the Characteristics sections of the specification is not implied. Exposure to limiting values for extended periods may affect device reliability.

Application information

Where application information is given, it is advisory and does not form part of the specification.

REMARK

All The specifications listed in this document are guaranteed for module only. Post-assembled operation or component(s) may impact module performance or cause unexpected effect or damage and therefore listed specifications is not warranted after any Post-assembled operation.

11. Reliability test

	TEST	CONDITION	METHOD	REMARK
1	High-Temperature Operation	T = +50°C, RH = 30% for 240 hrs	IEC 60 068-2-2Bp	
2	Low-Temperature Operation	T = 0°C for 240 hrs	IEC 60 068-2-2Ab	
3	High-Temperature Storage	T = +70°C, RH=40% for 240 hrs Test in white pattern	IEC 60 068-2-2Bp	
4	Low-Temperature Storage	T = -25°C for 240 hrs Test in white pattern	IEC 60 068-2-1Ab	
5	High-Temperature, High-Humidity Operation	T = +40°C, RH = 90% for 168 hrs	IEC 60 068-2-3CA	
6	High Temperature, High- Humidity Storage	T = +60°C, RH=80% for 240hrs Test in white pattern	IEC 60 068-2-3CA	
7	Temperature Cycle	-25°C → +70°C, 100 Cycles 30min 30min Test in white pattern	IEC 60 068-2-14	
8	Solar radiation test	765 W/m ² for 168hrs, 40°C Test in white pattern	IEC60 068-2-5Sa	
9	Package Vibration	1.04G, Frequency: 10~500Hz Direction: X,Y,Z Duration: 1 hours in each direction	Full packed for shipment	
10	Package Drop Impact	Drop from height of 122 cm on concrete surface. Drop sequence: 1 corner, 3 edges, 6 faces One drop for each.	Full packed for shipment	
11	Electrostatic Effect (non-operating)	(Machine model)+/- 250V 0Ω, 200pF	IEC 62179, IEC 62180	

Actual EMC level to be measured on customer application

Note: The protective film must be removed before temperature test.

< Criteria >

In the standard conditions, there is not display function NG issue occurred.
(Including : line defect, no image) All the cosmetic specification is judged before the reliability stress.

12. Bar Code definition

12-1) Panel Barcode Label

ECM 00 9 01 1 P 7 4 00361 A T
1 2 3 4 2 5 6 2 7 2 8

1 : EPD model code:

ED060KC1 : ECM , ECV , ECX

2 : Internal control codes:Do not care

3 : FPL reversion code

Carta : 9

4 : FPL batch code:

01~99	001~099	G0~G9	160~169	Q0~Q9	230~239	X0~X9	300~309
A0~A9	100~109	H0~H9	170~179	R0~R9	240~249	Y0~Y9	310~319
B0~B9	110~119	J0~J9	180~189	S0~S9	250~259	Z0~Z9	320~329
C0~C9	120~129	K0~K9	190~199	T0~T9	260~269		
D0~D9	130~139	L0~L9	200~209	U0~U9	270~279		
E0~E9	140~149	M0~M9	210~219	V0~V9	280~289		
F0~F9	150~159	N0~N9	220~229	W0~W9	290~299		

5 : Year:

N: 2013 / P: 2014 / Q: 2015 / R: 2016 /... / Z: 2024

6 : Month:

1:Jan. 2:Feb. ... 9:Sep. A:Oct. B:Nov. C:Dec.

7 : Serial number

00000-99999

8 : MFG code:

TOC FAB3 : T ; TOC FAB2 : Y ; TOC FAB1 : K ; E Ink Hsinchu : P ; MOS : S ; Microveiw : G ;
 TYT FAB5 : G ; TYT FAB4 : L

13. Border definition

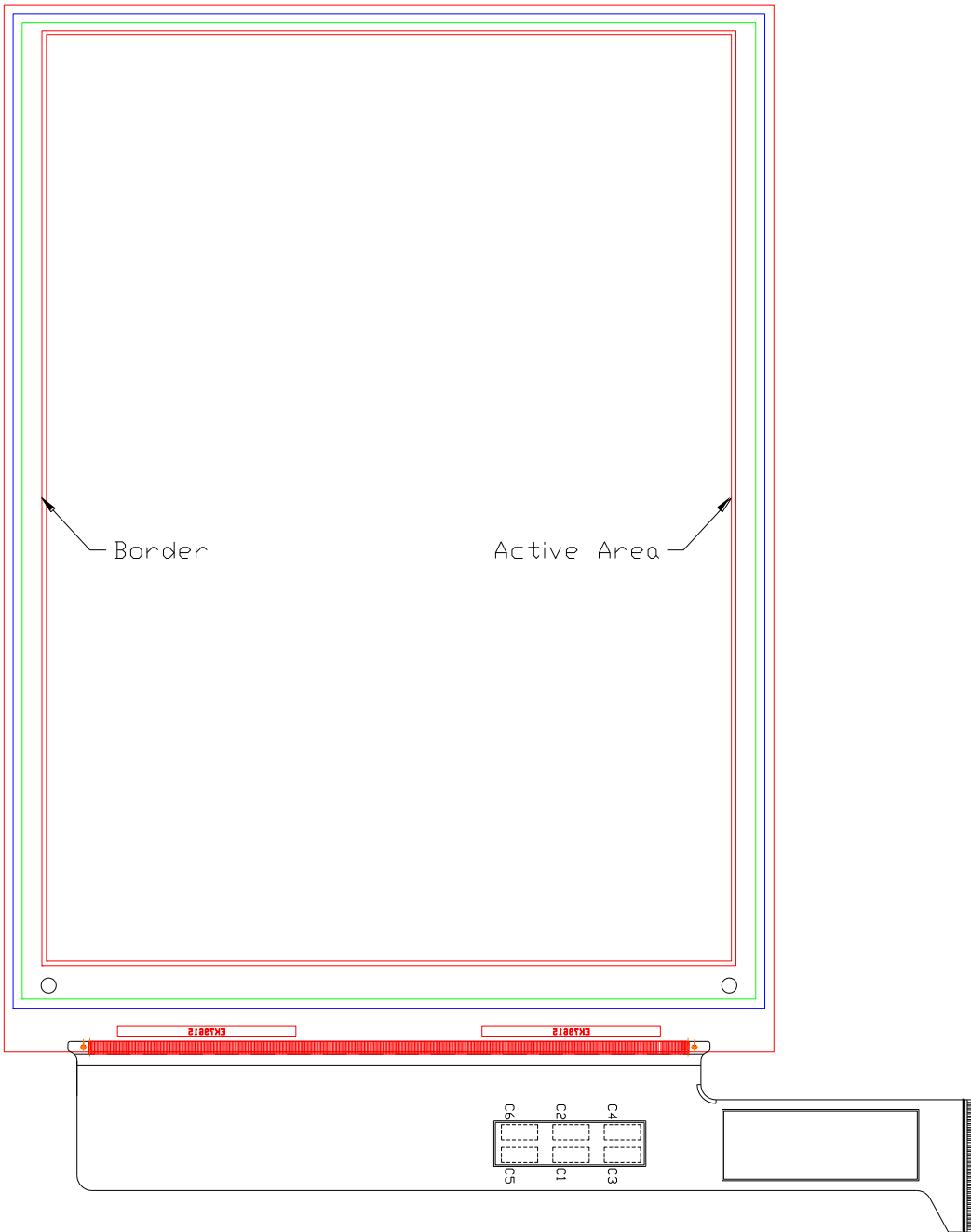

14. Block Diagram

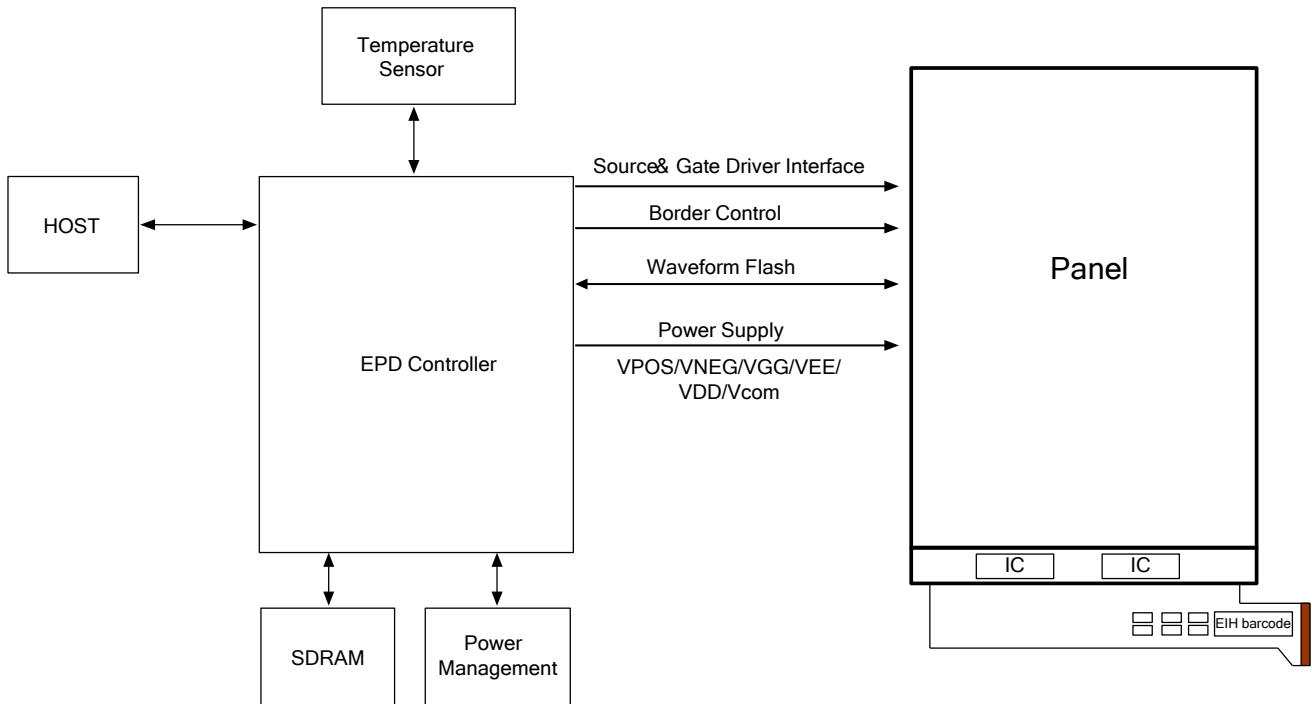

15.Packing

REV	DESCRIPTION	DESIGN	DATE
00	INITIAL RELEASE	Brian	'14.04.07

NOTE:

- One layer include: 1 piece of cushion sheet, 4 pcs module & 1 piece of tray.
- Q'TY: 48 pcs panel/carton.
- Dimension: 455*375*190mm
- Weight: 4.8 KG
- Make sure tray stacked with 180° rotation. We can check this by lateral side view.

9	EASY TAPE	48	For Remove Protect Sheet
8	30g加厚蜂窝状泡沫缓冲垫7.5*95mm	2	
7	防潮袋(保潔容量25L)	3	
6	CARTON INTERNAL	1	
5	摺口袋450*380*580mm	1	抗靜電
4	ED060KC1	48	
3	EPE CUSHION SHEET	12	抗靜電
2	TRAY	13	抗靜電
1	EPE FOAM	2	
ITEM	DESCRIPTION	QTY	REMARK

MTL.SPEC.		UNSPECIFIED TOL'S ±5.0mm		REMARK	
		ANGLE			
		ROUGHNESS			
APPROVE	Jimmy C	'14.04.07	SCALE	UNIT	SHEET
CHECK	Brian Chou	'14.04.07	1:1	mm	1 OF 1
DESIGN	Brian Chou	'14.04.07	MTL.NO.		DWG.NO.

Eink | 元太科技工業股份有限公司
E Ink Holdings Inc.

DWG.TITLE
ED060KC1 PACKING Dim

REV. 01 A4 SIZE



ALL TECHNOLOGIES. ALL COMPETENCIES. ONE SPECIALIST.



DATA MODUL AG
Landsberger Straße 322
DE-80687 Munich
Phone: +49-89-56017-0

DATA MODUL WEIKERSHEIM GMBH
Lindenstraße 8
DE-97990 Weikersheim
Phone: +49-7934-101-0



More information and worldwide locations can be found at

www.data-modul.com