



SPECIFICATION



G057QTN01.01

5.7" – QVGA – RGB/TTL

Version: 0.0

Date: 10.02.2023

Note: This specification is subject to change without prior notice

- Preliminary Specification
- Final Specification

Module	5.7 Inch Color TFT-LCD
Model Name	G057QTN01.0 (97D05G05.010)

<p>Customer</p> <p>_____</p>	<p>Date</p> <p>_____</p>
<p>Checked & Approved by</p> <p>_____</p>	

<p>Approved by</p> <p>_____</p>	<p>Date</p> <p>_____</p>
<p>LeaDer Feng</p>	<p>2022/10/25</p>
<p>Prepared by</p> <p>_____</p>	
<p>Danny Liao</p>	
<p>2022/10/25</p>	
<p>General Display Business Unit / AUO Display Plus Corporation</p>	

Contents

1. Operating Precautions	4
2. General Description	5
2.1 Display Characteristics	5
2.2 Optical Characteristics	6
3. Functional Block Diagram	9
4. Absolute Maximum Ratings.....	9
4.1 Absolute Ratings of TFT LCD Module.....	10
4.2 Absolute Ratings of Environment.....	10
5. Electrical Characteristics.....	11
5.1 TFT LCD Module	11
5.2 Backlight Unit.....	12
6. Signal Characteristic.....	14
6.1 Pixel Format Image.....	14
6.2 Scanning Direction.....	14
6.3 TFT- LCD Interface Signal Description	15
6.4 The Input Data Format.....	16
6.5 Interface Timing	17
6.6 LED Backlight Unit Interface Signal Description	18
6.7 Power ON/OFF Sequence	19
7. Connector & Pin Assignment	20
7.1 TFT- LCD Signal (CN1): LCD Connector	20
7.2 LED Backlight Unit (CN2): Backlight Connector	20
7.3 LED Light Bar Input (CN3): Light Bar Connector	21
7.4 Connector Illustration	21
7.4.1 PIN 1 definition of CN1 and CN2	21
7.4.2 PIN 1 definition of CN3	22
8. Reliability Test Criteria.....	23
9. Mechanical Characteristics	24
10. Label and Packaging.....	25
10.1 Shipping Label (on the rear side of TFT-LCD display).....	25
10.2 Carton Package	25
11 Safety.....	25
11.1 Sharp Edge Requirements.....	26
11.2 Materials.....	26
11.3 Capacitors.....	26
11.4 National Test Lab Requirement.....	26

Record of Revision

Version and Date	Page	Old description	New Description																																																																						
0.0 2022/01/25	All	First edition																																																																							
0.1 2022/04/13	18	LED Pin#6 description 6 [⊕] VENABLE [⊕] 0V-Off; 2-5V/NC-On [⊕]	Modify LED Pin#6 description 6 [⊕] VENABLE [⊕] 0V-Off; 2-5V-On [⊕]																																																																						
0.2 2022/05/12	5	Light Bar Unit [⊕] LED, Replaceable [⊕]	Light Bar Unit [⊕] LED [⊕]																																																																						
	18	LED Pin#6 description 6 [⊕] VENABLE [⊕] 0V-Off; 2-5V-On [⊕]	Modify LED Pin#6 description 6 [⊕] VENABLE [⊕] 0V-Off; 2-5V/NC-On [⊕]																																																																						
0.3 2022/07/21	11	Inrush [⊕] LCD Inrush Current [⊕] 280 [⊕] [A] [⊕] Note 1 [⊕]	Inrush [⊕] LCD Inrush Current [⊕] 280 [⊕] [mA] [⊕] Note 1 [⊕]																																																																						
	24	<p>The hole for nominal size 3mm self-tapping screw attachment; depth 5.0mm±0.5mm (4 point) Suggested applying torque: 0.15~0.2Nm</p> <p>NOTE: 1.CNH1/F CONNECTOR IS 089H33-000100-G2-R (STARCONN) CNLED DRIVER CONNECTOR IS SM06B-SRKHFSLF*SNX(JST) 2.TOLERANCE IS ±0.5 IF NOT SPECIFIED.</p>	<p>The hole for nominal size 3mm self-tapping screw attachment; depth 5.0mm±0.5mm (4 point)</p> <p>NOTE: 1.CNH1/F CONNECTOR IS 089H33-000100-G2-R (STARCONN) CNLED DRIVER CONNECTOR IS SM06B-SRKHFSLF*SNX(JST) 2.TOLERANCE IS ±0.5 IF NOT SPECIFIED.</p> <p>Note: Please evaluate the tightening torque according to customer's application.</p>																																																																						
1.0 2022/10/25	12	<p>5.2 Backlight Unit- 5.2.1 Parameter guideline for LED- Following characteristics are measured under stable condition using a LED driving board at 25°C (Room Temperature).</p> <table border="1"> <thead> <tr> <th>Symbol</th> <th>Parameter</th> <th>Min.</th> <th>Typ.</th> <th>Max.</th> <th>Units</th> <th>Remark</th> </tr> </thead> <tbody> <tr> <td>V_{LED}[⊕]</td> <td>Input Voltage</td> <td>9.</td> <td>12.</td> <td>20.</td> <td>Volt.</td> <td>-</td> </tr> <tr> <td>I_{LED}[⊕]</td> <td>Input Current</td> <td>-</td> <td>0.12.</td> <td>0.14.</td> <td>A.</td> <td>V_{LED} = 12V, D_{DUTY} = 100%</td> </tr> <tr> <td>P_{LED}[⊕]</td> <td>Power Consumption</td> <td>-</td> <td>1.44.</td> <td>1.68.</td> <td>W.</td> <td>V_{LED} = 12V, D_{DUTY} = 100%</td> </tr> <tr> <td>Inrush_{LED}[⊕]</td> <td>Inrush Current</td> <td>-</td> <td>-</td> <td>1.5.</td> <td>A.</td> <td>V_{LED} = 12V, D_{DUTY} = 100%</td> </tr> </tbody> </table>	Symbol	Parameter	Min.	Typ.	Max.	Units	Remark	V _{LED} [⊕]	Input Voltage	9.	12.	20.	Volt.	-	I _{LED} [⊕]	Input Current	-	0.12.	0.14.	A.	V _{LED} = 12V, D _{DUTY} = 100%	P _{LED} [⊕]	Power Consumption	-	1.44.	1.68.	W.	V _{LED} = 12V, D _{DUTY} = 100%	Inrush _{LED} [⊕]	Inrush Current	-	-	1.5.	A.	V _{LED} = 12V, D _{DUTY} = 100%	<p>Update LED Input current and power 5.2 Backlight Unit- 5.2.1 Parameter guideline for LED- Following characteristics are measured under stable condition using a LED driving board at 25°C (Room Temperature).</p> <table border="1"> <thead> <tr> <th>Symbol</th> <th>Parameter</th> <th>Min.</th> <th>Typ.</th> <th>Max.</th> <th>Units</th> <th>Remark</th> </tr> </thead> <tbody> <tr> <td>V_{LED}[⊕]</td> <td>Input Voltage</td> <td>9.</td> <td>12.</td> <td>20.</td> <td>Volt.</td> <td>-</td> </tr> <tr> <td>I_{LED}[⊕]</td> <td>Input Current</td> <td>-</td> <td>0.12.</td> <td>0.16.</td> <td>A.</td> <td>V_{LED} = 12V, D_{DUTY} = 100%</td> </tr> <tr> <td>P_{LED}[⊕]</td> <td>Power Consumption</td> <td>-</td> <td>1.44.</td> <td>1.92.</td> <td>W.</td> <td>V_{LED} = 12V, D_{DUTY} = 100%</td> </tr> <tr> <td>Inrush_{LED}[⊕]</td> <td>Inrush Current</td> <td>-</td> <td>-</td> <td>1.5.</td> <td>A.</td> <td>V_{LED} = 12V, D_{DUTY} = 100%</td> </tr> </tbody> </table>	Symbol	Parameter	Min.	Typ.	Max.	Units	Remark	V _{LED} [⊕]	Input Voltage	9.	12.	20.	Volt.	-	I _{LED} [⊕]	Input Current	-	0.12.	0.16.	A.	V _{LED} = 12V, D _{DUTY} = 100%	P _{LED} [⊕]	Power Consumption	-	1.44.	1.92.	W.	V _{LED} = 12V, D _{DUTY} = 100%	Inrush _{LED} [⊕]	Inrush Current	-	-	1.5.	A.	V _{LED} = 12V, D _{DUTY} = 100%
Symbol	Parameter	Min.	Typ.	Max.	Units	Remark																																																																			
V _{LED} [⊕]	Input Voltage	9.	12.	20.	Volt.	-																																																																			
I _{LED} [⊕]	Input Current	-	0.12.	0.14.	A.	V _{LED} = 12V, D _{DUTY} = 100%																																																																			
P _{LED} [⊕]	Power Consumption	-	1.44.	1.68.	W.	V _{LED} = 12V, D _{DUTY} = 100%																																																																			
Inrush _{LED} [⊕]	Inrush Current	-	-	1.5.	A.	V _{LED} = 12V, D _{DUTY} = 100%																																																																			
Symbol	Parameter	Min.	Typ.	Max.	Units	Remark																																																																			
V _{LED} [⊕]	Input Voltage	9.	12.	20.	Volt.	-																																																																			
I _{LED} [⊕]	Input Current	-	0.12.	0.16.	A.	V _{LED} = 12V, D _{DUTY} = 100%																																																																			
P _{LED} [⊕]	Power Consumption	-	1.44.	1.92.	W.	V _{LED} = 12V, D _{DUTY} = 100%																																																																			
Inrush _{LED} [⊕]	Inrush Current	-	-	1.5.	A.	V _{LED} = 12V, D _{DUTY} = 100%																																																																			

1. Operating Precautions

- 1) Since front polarizer is easily damaged, please be cautious and not to scratch it.
- 2) Be sure to turn off power supply when inserting or disconnecting from input connector.
- 3) Wipe off water drop immediately. Long contact with water may cause discoloration or spots.
- 4) When the panel surface is soiled, wipe it with absorbent cotton or soft cloth.
- 5) Since the panel is made of glass, it may be broken or cracked if dropped or bumped on hard surface.
- 6) Since CMOS LSI is used in this module, take care of static electricity and insure human earth when handling.
- 7) Do not open nor modify the module assembly.
- 8) Do not press the reflector sheet at the back of the module to any direction.
- 9) In case if a module has to be put back into the packing container slot after it was taken out from the container, do not press the center of the LED Reflector edge. Instead, press at the far ends of the LED Reflector edge softly. Otherwise the TFT Module may be damaged.
- 10) At the insertion or removal of the Signal Interface Connector, be sure not to rotate nor tilt the Interface Connector of the TFT Module.
- 11) TFT-LCD Module is not allowed to be twisted & bent even force is added on module in a very short time. Please design your display product well to avoid external force applying to module by end-user directly.
- 12) Small amount of materials without flammability grade are used in the TFT-LCD module. The TFT-LCD module should be supplied by power complied with requirements of Limited Power Source (IEC60950-1 or UL60950-1), or be applied exemption.
- 13) Severe temperature condition may result in different luminance, response time.
- 14) Continuous operating TFT-LCD Module under high temperature environment may accelerate LED light bar exhaustion and reduce luminance dramatically.
- 15) The data on this specification sheet is applicable when TFT-LCD module is placed in landscape position.
- 16) Continuous displaying fixed pattern may induce image sticking. It's recommended to use screen saver or moving content periodically if fixed pattern is displayed on the screen.

2. General Description

G057QTN01.0 is a Color Active Matrix Liquid Crystal Display composed of a TFT-LCD display, a driver circuit, and a backlight system. The screen format is intended to support QVGA (320(H) x 240(V)) screen and 262K (RGB 6-bits). All input signals are CMOS interface compatible.

G057QTN01.0 is designed for industrial display applications.

2.1 Display Characteristics

The following items are characteristics summary on the table under 25 °C condition:

Items	Unit	Specifications
Screen Diagonal	[inch]	5.7
Active Area	[mm]	115.2(H) x 86.4(V)
Pixels H x V		320x3(RGB)x240
Pixel Pitch	[mm]	0.36 x 0.36
Pixel Arrangement		R.G.B. Vertical Stripe
Display Mode		TN, Normally White
Nominal Input Voltage VDD	[Volt]	3.3 typ.
Typical Power Consumption	[Watt]	1.506W (LCD: 0.066W / LED BLU: 1.44W) @ All black pattern, Full Load and VLED=12V
Weight	[Grams]	150g (typ.), 165g (max.)
Physical Size	[mm]	144.0(H)x 104.6(V) x 12.3(D) (typ.)
Electrical Interface		CMOS 6-bit Parallel RGB
Surface Treatment		Anti-Glare, Hardness 3H
Support Color		262K colors
Temperature Range		
Operating	[°C]	-30 to +85
Storage (Non-Operating)	[°C]	-30 to +85
RoHS Compliance		RoHS Compliance
Light Bar Unit		LED

2.2 Optical Characteristics

The optical characteristics are measured under stable conditions at 25°C (Room Temperature):

Item	Unit	Conditions	Min.	Typ.	Max.	Note
White Luminance	[cd/m ²]	V _{LED} =12V, D _{PWM} =100% (center point)	400	500	-	1
Uniformity		5 Points			1.3	1, 2, 3
Contrast Ratio			500	700	-	4
Cross talk	%		-	1.2	1.5	5
Response Time	[msec]	Rising	-	15	20	6
	[msec]	Falling	-	10	15	
	[msec]	Raising + Falling	-	25	35	
Viewing Angle	[degree]	Horizontal (Right) CR = 10 (Left)	70	80	-	7
	[degree]		70	80	-	
	[degree]	Vertical (Upper) CR = 10 (Lower)	60	70	-	
	[degree]		60	70	-	
Color / Chromaticity Coordinates (CIE 1931)		White x	0.263	0.313	0.363	
		White y	0.279	0.329	0.379	
		Red x	0.491	0.541	0.591	
		Red y	0.253	0.303	0.353	
		Green x	0.279	0.329	0.379	
		Green y	0.559	0.609	0.659	
		Blue x	0.111	0.161	0.211	
		Blue y	0.064	0.114	0.164	
Color Gamut	%			50		

Note 1: Measurement method

Equipment Pattern Generator, Power Supply, Digital Voltmeter, Luminance meter (SR_3 or equivalent)

Aperture 1° with 50cm viewing distance

Test Point Center

Environment < 1 lux

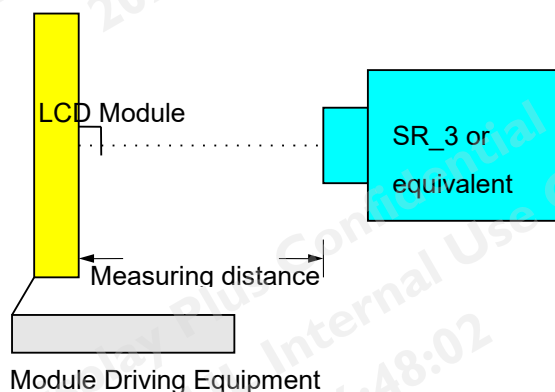

Note 2: Definition of 9 points position (Display active area: 115.2(H) x 86.4(V))

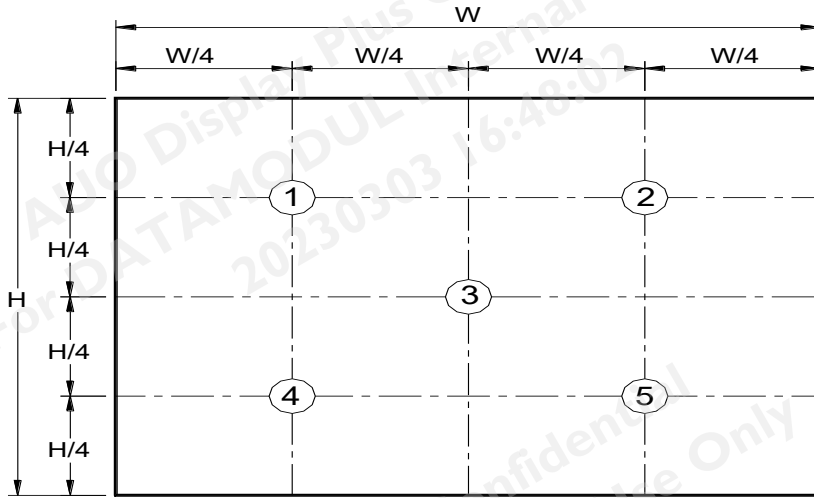

Note 3: The luminance uniformity of 9 points is defined by dividing the minimum luminance values by the maximum test point luminance

$$\delta_{w9} = \frac{\text{Minimum Brightness of nine points}}{\text{Maximum Brightness of nine points}}$$

Note 4 : Definition of contrast ratio (CR):

$$\text{Contrast ratio (CR)} = \frac{\text{Brightness on the "White" state}}{\text{Brightness on the "Black" state}}$$

Note 5 : Definition of cross talk (CT)

$$CT = |YB - YA| / YA \times 100 (\%)$$

Where

YA = Luminance of measured location without gray level 0 pattern (cd/m2)

YB = Luminance of measured location with gray level 0 pattern (cd/m2)

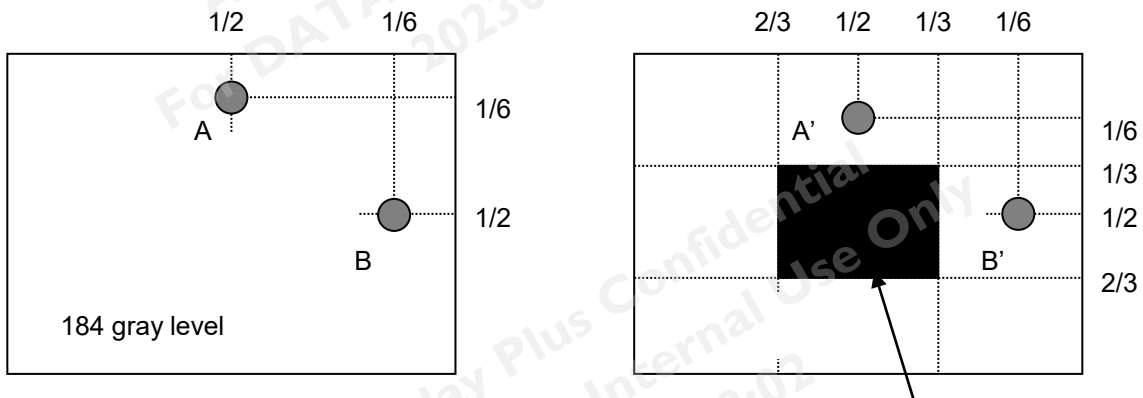

Note 6: Definition of response time:

The output signals of photo detector are measured when the input signals are changed from “White” to “Black” (falling time) and from “Black” to “White” (rising time), respectively. The response time interval is between 10% and 90% of amplitudes. Please refer to the figure as below.

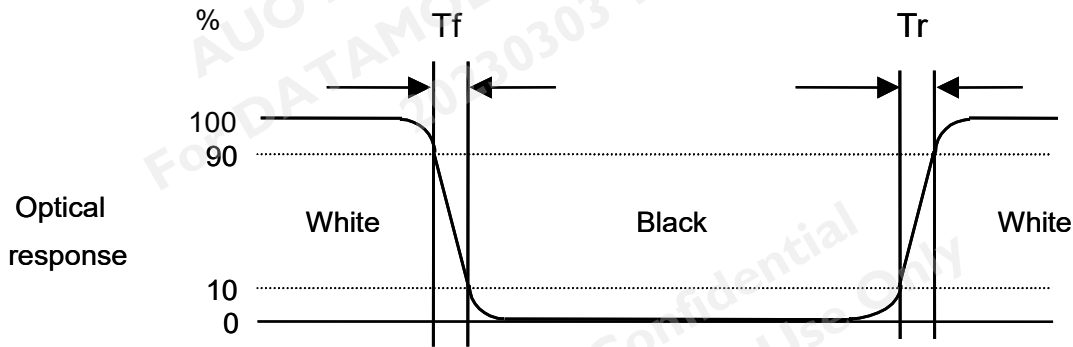

Note 7: Definition of viewing angle

Viewing angle is the measurement of contrast ratio ≥ 10 , at the screen center, over a 180° horizontal and 180° vertical range (off-normal viewing angles). The 180° viewing angle range is broken down as below: 90° (θ) horizontal left and right, and 90° (Φ) vertical high (up) and low (down). The measurement direction is typically perpendicular to the display surface with the screen rotated to its center to develop the desired measurement viewing angle.

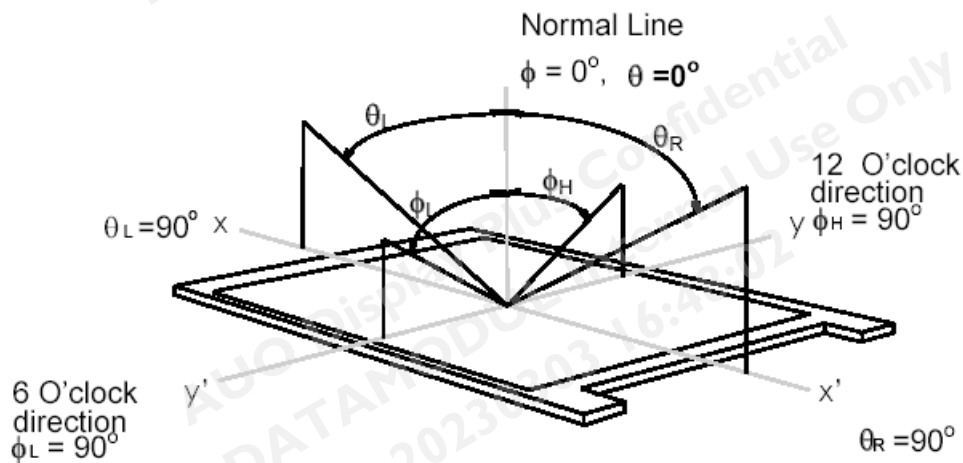

3. Functional Block Diagram

The following diagram shows the functional block of the 5.7 inch color TFT/LCD module:

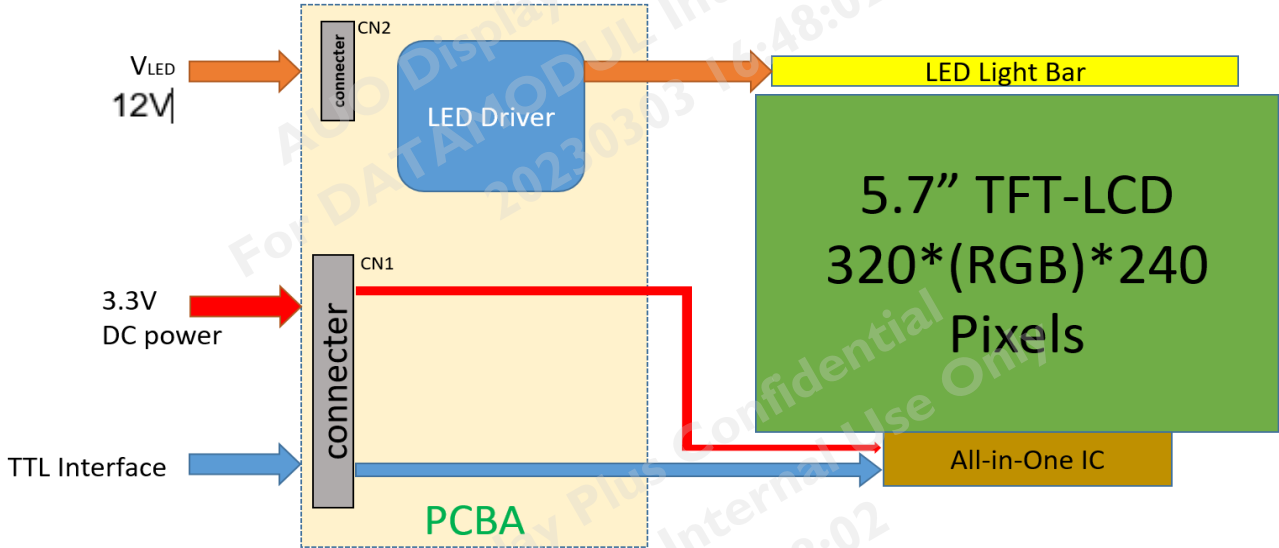

4. Absolute Maximum Ratings

4.1 Absolute Ratings of TFT LCD Module

Item	Symbol	Min	Max	Unit	Remark
Logic/LCD Drive Voltage	VDD	-0.3	+4.0	Volt	Ta= 25°C
LCD Input Signal Voltage	VIN	-0.3	+4.0	Volt	Ta= 25°C
LED Input Voltage	V _{LED}	-0.3	+26	Volt	Ta= 25°C
LED Dimming Voltage	V _{PWM}	0	8	Volt	Ta= 25°C
LED Enable Voltage	V _{Enable}	0	20	Volt	Ta= 25°C

4.2 Absolute Ratings of Environment

Item	Symbol	Min	Max	Unit	Remark
Operating Temperature	TOP	-30	+85	°C	Note 1, 2
Operation Humidity	HOP	5	90	%RH	Note 1, 2
Storage Temperature	TST	-30	+85	°C	Note 1
Storage Humidity	HST	5	90	%RH	Note 1

Note 1: Maximum Wet-Bulb should be 39°C and no condensation.

Note 2: Only operation is guaranteed. Optical performance should be evaluated at 25°C only.

5. Electrical Characteristics

5.1 TFT LCD Module

5.1.1 Power Specification

Symbol	Parameter	Min	Typ	Max	Units	Remark
VDD	Logic/LCD Drive Voltage	3.0	3.3	3.6	[Volt]	
IDD	VDD Current	-	20	24	[mA]	All Black Pattern (VDD=3.3V, at 60Hz)
Irush	LCD Inrush Current	-	-	280	[mA]	Note 1
PDD	VDD Power		0.066	0.079	[Watt]	All Black Pattern (VDD=3.3V, at 60Hz)
VDDrp	Allowable Logic/LCD Drive Ripple Voltage	-	-	100	mVp-p	All Black Pattern (VDD=3.3V, at 60Hz)

Note 1: Measurement condition:

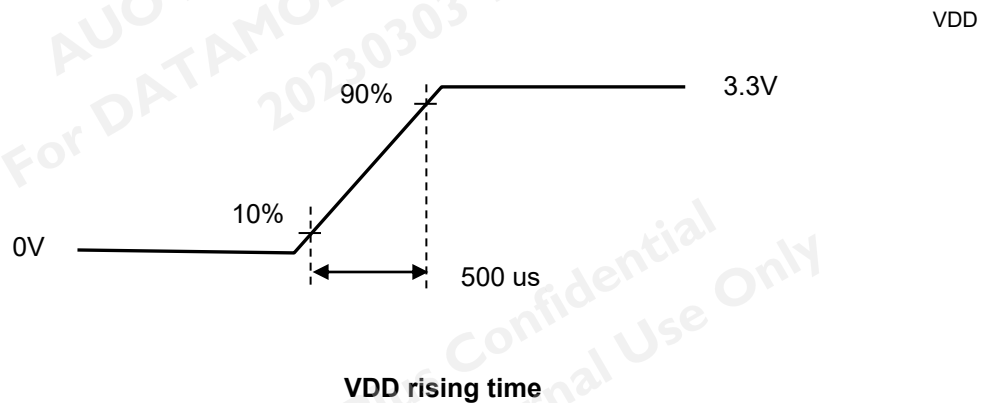

5.1.2 Signal Electrical Characteristics

Input signals shall be low or Hi-Z state when VDD is off.

Parameter		Symbol	Min.	Typ.	Max.	Unit	Remarks
Logic Input Voltage for Display Signals	High	VIH	0.7VDD	-	VDD	Volt	
	Low	VIL	0	-	0.3VDD	Volt	
Input Voltage for RL/UD	High	VIH	0.7VDD	-	VDD	Volt	
	Low	VIL	0	-	0.2VDD	Volt	

5.2 Backlight Unit

5.2.1 Parameter guideline for LED

Following characteristics are measured under stable condition using a LED driving board at 25°C(Room Temperature).

Symbol	Parameter	Min	Typ	Max	Units	Remark
V _{LED}	Input Voltage	9	12	20	Volt	
I _{LED}	Input Current	-	0.12	0.16	A	V _{LED} = 12V, D _{PWM} = 100%
P _{LED}	Power Consumption	-	1.44	1.92	W	V _{LED} = 12V, D _{PWM} = 100%
I _{rushLED}	Inrush Current	-		1.5	A	V _{LED} = 12V, D _{PWM} = 100%
V _{PWM}	Dimming control Voltage High	2.0	3.3	5	Volt	Note 1,2
	Dimming control Voltage Low	-	-	0.15	Volt	
F _{PWM}	Dimming Frequency	200		30K	Hz	
D _{PWM}	Dimming duty cycle	1		100	%	
V _{ENABLE}	On Control Voltage	2	3.3	5	Volt	Note 3, 4
	Off Control Voltage	-	-	0.8	Volt	
I _F	LED Forward Current		50		mA	Ta = 25oC
V _F	LED Forward Voltage				Volt	IF = 50mA, Ta = -30oC
		24	25.6	28.8	Volt	IF = 50mA, Ta = 25oC
					Volt	IF = 50mA, Ta = 85oC
P _{LED}	LED Power		1.28		Watt	
Operating Life		50000	-	-	Hrs	Note 5, 6

Note 1: PWM dimming function can be operated by PWM signal. PWM duty cycle can adjust white Luminance.

(PWM High: ON and PWM Low: OFF)

Note 2: PWM signal can not be floating and pull-down to ground when waiting.

Note 3: V_{ENABLE} must be turned on late than V_{LED} and PWM Signal.



AUO Display+

Note 4: V_{ENABLE} must be turned off early than V_{LED} and PWM Signal.

Note 5: If G057QTN01.0 module is driven by high current or at high ambient temperature & humidity condition. The operating life will be reduced.

Note 6: Operating life means brightness goes down to 50% initial brightness. Minimum operating life time is estimated data.

AUO Display Plus Confidential
For DATAMODUL Internal Use Only
20230303 16:48:02

AUO Display Plus Confidential
For DATAMODUL Internal Use Only
20230303 16:48:02

AUO Display Plus Confidential
For DATAMODUL Internal Use Only
20230303 16:48:02

AUO Display Plus Confidential
For DATAMODUL Internal Use Only
20230303 16:48:02

6. Signal Characteristic

6.1 Pixel Format Image

Following figure shows the relationship between input signal and LCD pixel format.

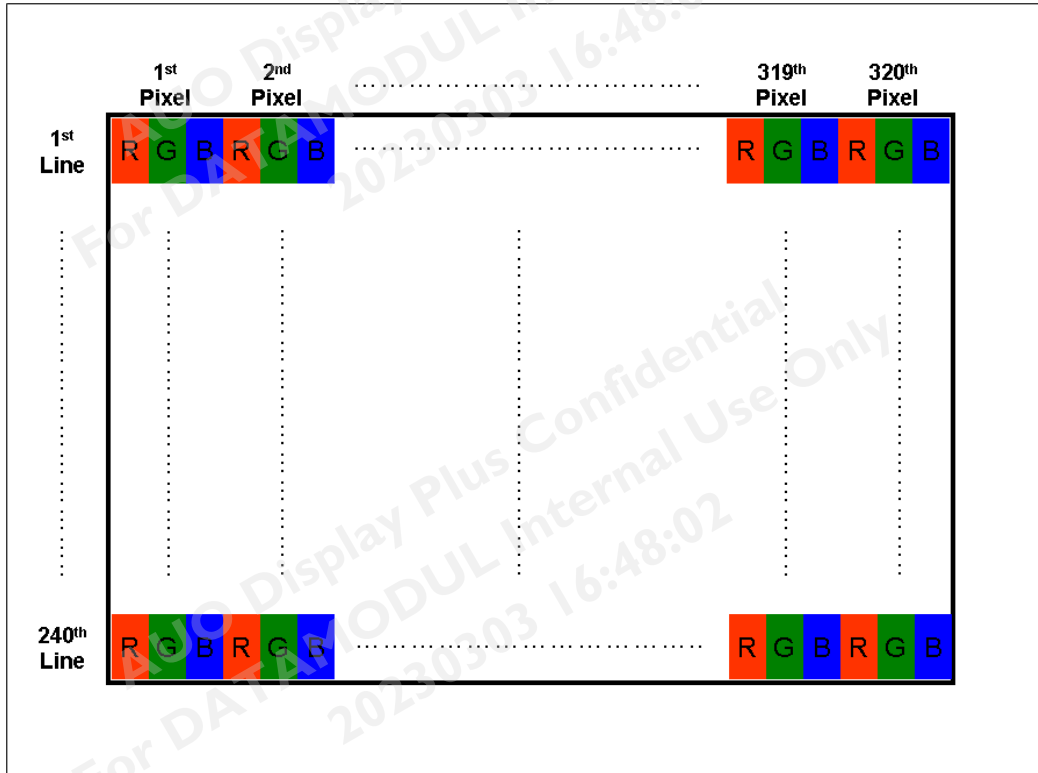

6.2 Scanning Direction

The following figures show the image seen from the front view. The arrow indicates the direction of scan.



R/L=Low or NC; U/D=High or NC



R/L=High; U/D=High or NC



R/L=Low or NC; U/D=Low



R/L=High; U/D=Low

6.3 TFT- LCD Interface Signal Description

Pin#	Signal Name	Description
1	GND	Ground
2	DOTCLK	Dot clock
3	NC	NC
4	NC	NC
5	GND	Ground
6	R0	Red data(LSB)
7	R1	Red data
8	R2	Red data
9	R3	Red data
10	R4	Red data
11	R5	Red data(MSB)
12	GND	Ground
13	G0	Green data(LSB)
14	G1	Green data
15	G2	Green data
16	G3	Green data
17	G4	Green data
18	G5	Green data(MSB)
19	GND	Ground
20	B0	Blue data(LSB)
21	B1	Blue data
22	B2	Blue data
23	B3	Blue data
24	B4	Blue data
25	B5	Blue data(MSB)
26	GND	Ground
27	DE	Data enable signal
28	VDD	Power supply (3.3V Typ. Only)
29	VDD	Power supply (3.3V Typ. Only)
30	R/L	Horizontal reverse scan
31	U/D	Vertical reverse scan
32	NC	NC
33	GND	Ground

Note 1: "Low" stands for 0V. "High" stands for 3.3V. "NC" stands for "No Connection".

6.4 The Input Data Format

This product displays 262,144 colors in terms of the 64 grey levels on RGB respectively. The following table demonstrates the display of input data.

Display colors		Data signal (0 : Low level, 1: High level)																	
		R5	R4	R3	R2	R1	R0	G5	G4	G3	G2	G1	G0	B5	B4	B3	B2	B1	B0
Basic colors	Black	0	0	0	0	0	0	0	0	0	0	0	0	0	0	0	0	0	0
	Blue	0	0	0	0	0	0	0	0	0	0	0	0	1	1	1	1	1	1
	Red	1	1	1	1	1	1	0	0	0	0	0	0	0	0	0	0	0	0
	Magenta	1	1	1	1	1	1	0	0	0	0	0	0	1	1	1	1	1	1
	Green	0	0	0	0	0	0	1	1	1	1	1	1	0	0	0	0	0	0
	Cyan	0	0	0	0	0	0	1	1	1	1	1	1	1	1	1	1	1	1
	Yellow	1	1	1	1	1	1	1	1	1	1	1	1	0	0	0	0	0	0
	White	1	1	1	1	1	1	1	1	1	1	1	1	1	1	1	1	1	1
Red grayscale	Black	0	0	0	0	0	0	0	0	0	0	0	0	0	0	0	0	0	0
	Dark	0	0	0	0	0	1	0	0	0	0	0	0	0	0	0	0	0	0
	↑																		
	↓																		
	bright	1	1	1	1	0	1	0	0	0	0	0	0	0	0	0	0	0	0
	Red	1	1	1	1	1	0	0	0	0	0	0	0	0	0	0	0	0	0
Green grayscale	Black	0	0	0	0	0	0	0	0	0	0	0	0	0	0	0	0	0	0
	Dark	0	0	0	0	0	0	0	0	0	0	0	1	0	0	0	0	0	0
	↑																		
	↓																		
	bright	0	0	0	0	0	0	1	1	1	1	0	1	0	0	0	0	0	0
	Green	0	0	0	0	0	0	1	1	1	1	1	1	0	0	0	0	0	0
Blue grayscale	Black	0	0	0	0	0	0	0	0	0	0	0	0	0	0	0	0	0	0
	Dark	0	0	0	0	0	0	0	0	0	0	0	0	0	0	0	0	0	1
	↑																		
	↓																		
	bright	0	0	0	0	0	0	0	0	0	0	0	0	1	1	1	1	0	1
	Blue	0	0	0	0	0	0	0	0	0	0	0	0	1	1	1	1	1	1

6.5 Interface Timing

6.5.1 Timing Characteristics

Parameter		Symbol	Min.	Typ.	Max.	Unit
Clock frequency		$1/T_{\text{Clock}}$	5	6	8	MHz
Data	Setup Time	T_{dsu}	12			ns
	Hold Time	T_{dhd}	12			ns
DE	Setup Time	T_{dest}	12			ns
	Hold Time	T_{dehd}	12			ns
HSYNC	Period Time	T_{h}	325	371	438	DCLK
	Display Period	T_{hdisp}		320		
	Back Porch	T_{hbp}	3	43	43	
	Front Porch	T_{hfp}	2	8	75	
	Pulse Width	T_{hw}	2	4	43	
VSYNC	Period Time	T_{v}	244	260	289	HSYNC
	Display Period	T_{vdisp}		240		
	Back Porch	T_{vbp}	2	12	12	
	Front Porch	T_{vfp}	2	8	37	
	Pulse Width	T_{vw}	2	4	12	
Frame Rate		F		60	70	Hz

Note: DE mode only.

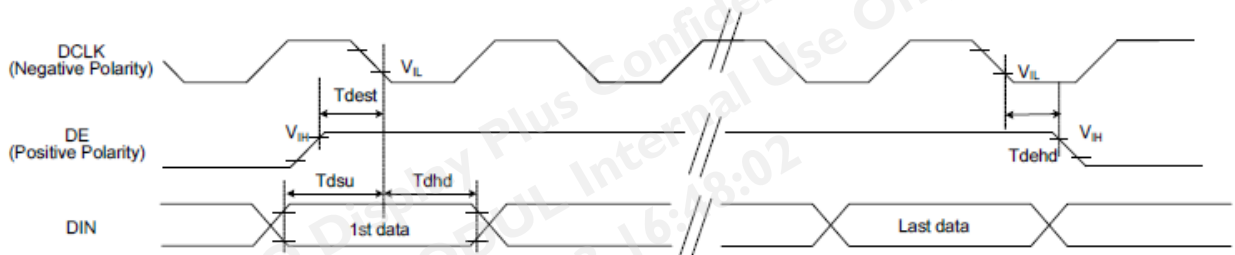

6.5.2 Input Timing Diagram

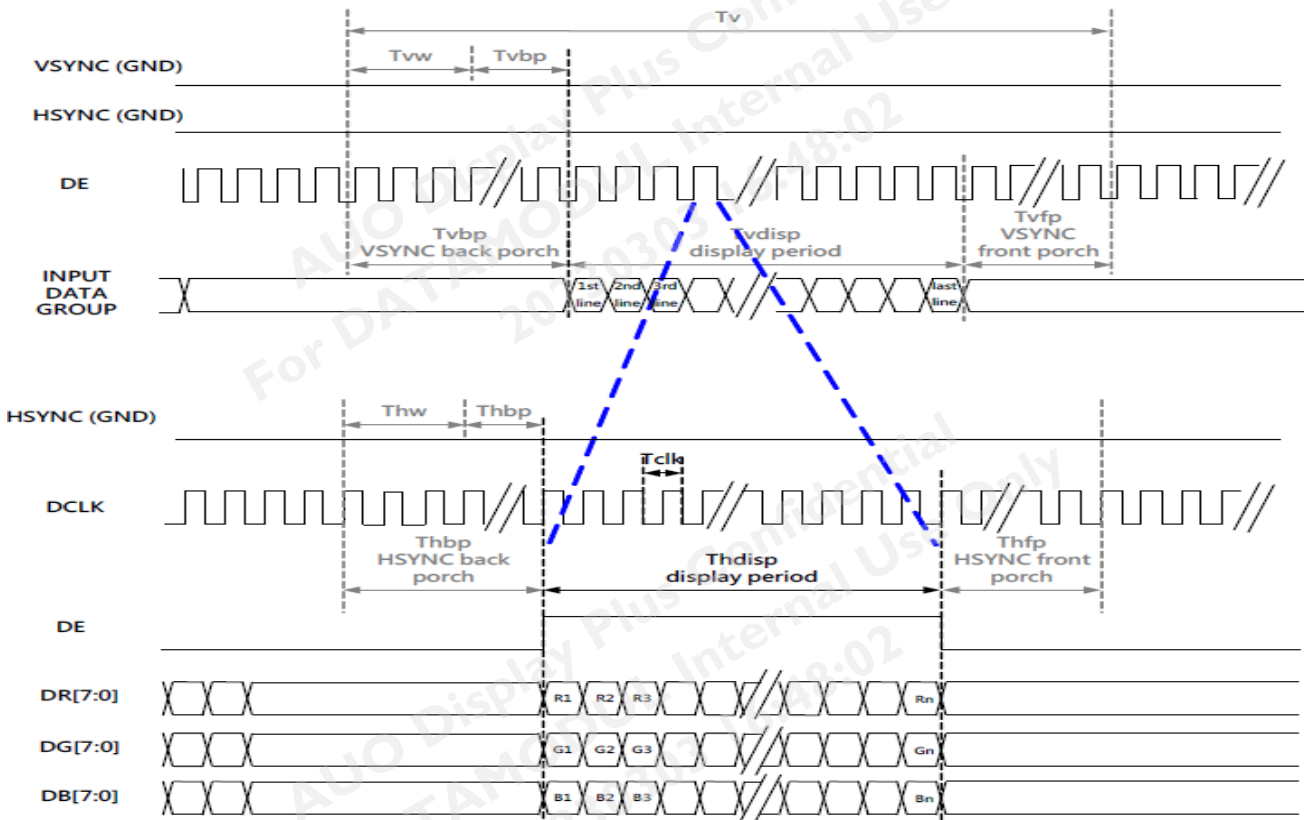

6.6 LED Backlight Unit Interface Signal Description

Pin #	Symbol	Pin Description
1	V_{LED}	12V input
2	V_{LED}	12V input
3	GND	Ground
4	GND	Ground
5	V_{PWM}	1~100% PWM dimming
6	V_{ENABLE}	0V-Off; 2~5V/NC-On

Note 1: "NC" stands for "No Connection"

6.7 Power ON/OFF Sequence

VDD power and LED on/off sequence is as below. Interface signals are also shown in the chart. Signals from any system shall be Hi-Z state or low level when VDD is off.

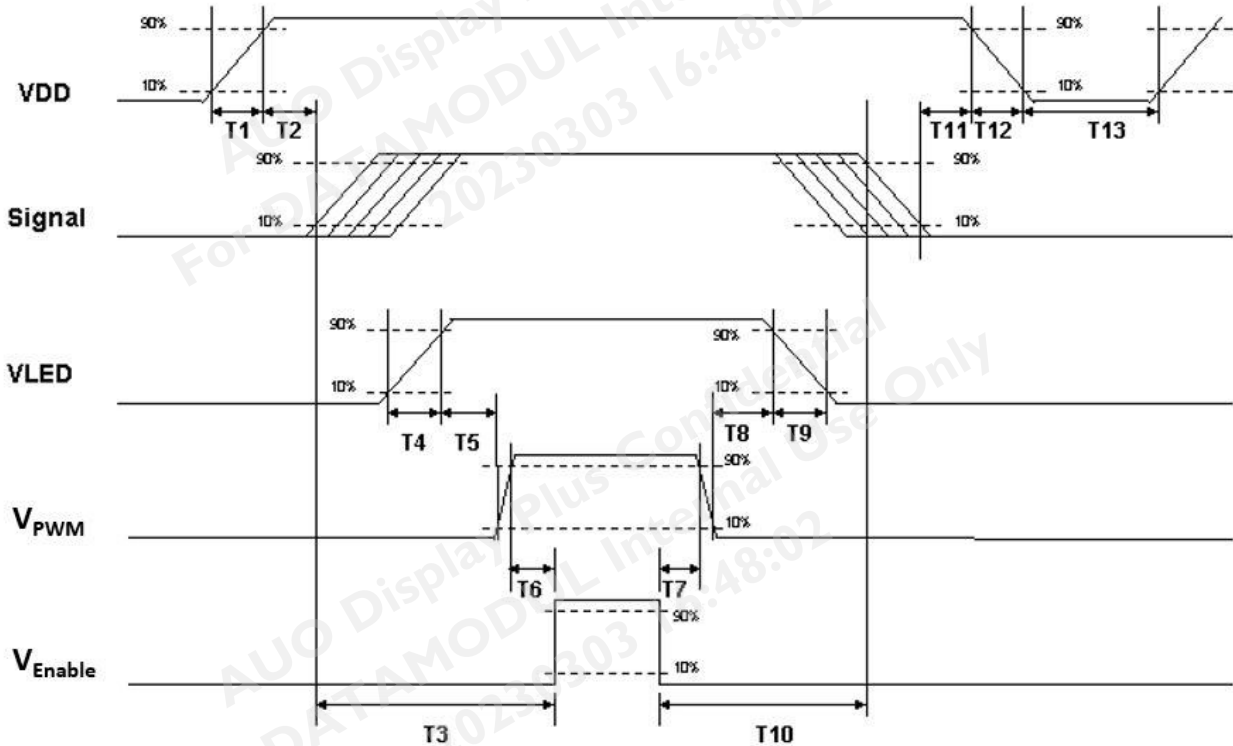

Power ON/OFF sequence timing

Parameter	Value			Units
	Min.	Typ.	Max.	
T1	0.5	-	10	[ms]
T2	30	40	50	[ms]
T3	200	-	-	[ms]
T4	0.5	-	10	[ms]
T5	10	-	-	[ms]
T6	10	-	-	[ms]
T7	0	-	-	[ms]
T8	10	-	-	[ms]
T9	-	-	10	[ms]
T10	110	-	-	[ms]
T11	0	16	50	[ms]
T12	-	-	10	[ms]
T13	1000	-	-	[ms]

The above on/off sequence should be applied to avoid abnormal function in the display. Please make sure to turn off the power when you plug the cable into the input connector or pull the cable out of the connector.

7. Connector & Pin Assignment

Physical interface is described as for the connector on module. These connectors are capable of accommodating the following signals and will be following components.

7.1 TFT- LCD Signal (CN1): LCD Connector

Manufacturer	Starconn
Connector Model Number	089H33-000100-G2-R, compatible with MS2406P33M

7.2 LED Backlight Unit (CN2): Backlight Connector

Manufacturer	JST
Connector Model Number	SM06B-SRKS-G-TB compatible with JST SM06B-SRSS-TB (LS) (SN)
Mating Connector Model Number	JST SHR-06V-BKHF-B or compatible

7.3 LED Light Bar Input (CN3): Light Bar Connector

Manufacturer	STM or compatible
Connector Model Number	P24021P6 or compatible
Mating Connector Model Number	SM06B-SHLK-G-TF or compatible

Pin #	Symbol	Pin Description	Cable color
1	AN1	Channel 1 LED anode	Red
2	AN2	Channel 2 LED anode	Red
3	AN3	Channel 3 LED anode	Red
4	CA1	Channel 1 LED cathode	White
5	CA2	Channel 2 LED cathode	Blue
6	CA3	Channel 3 LED cathode	Black

7.4 Connector Illustration

7.4.1 PIN 1 definition of CN1 and CN2

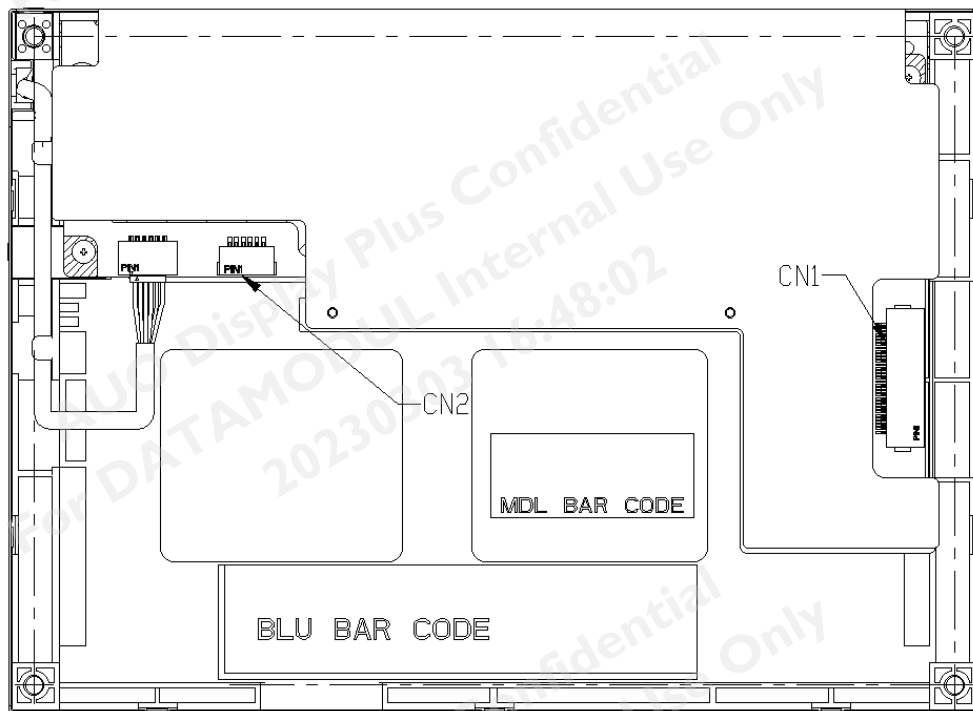

(Rear side of TFT-LCD)

7.4.2 PIN 1 definition of CN3

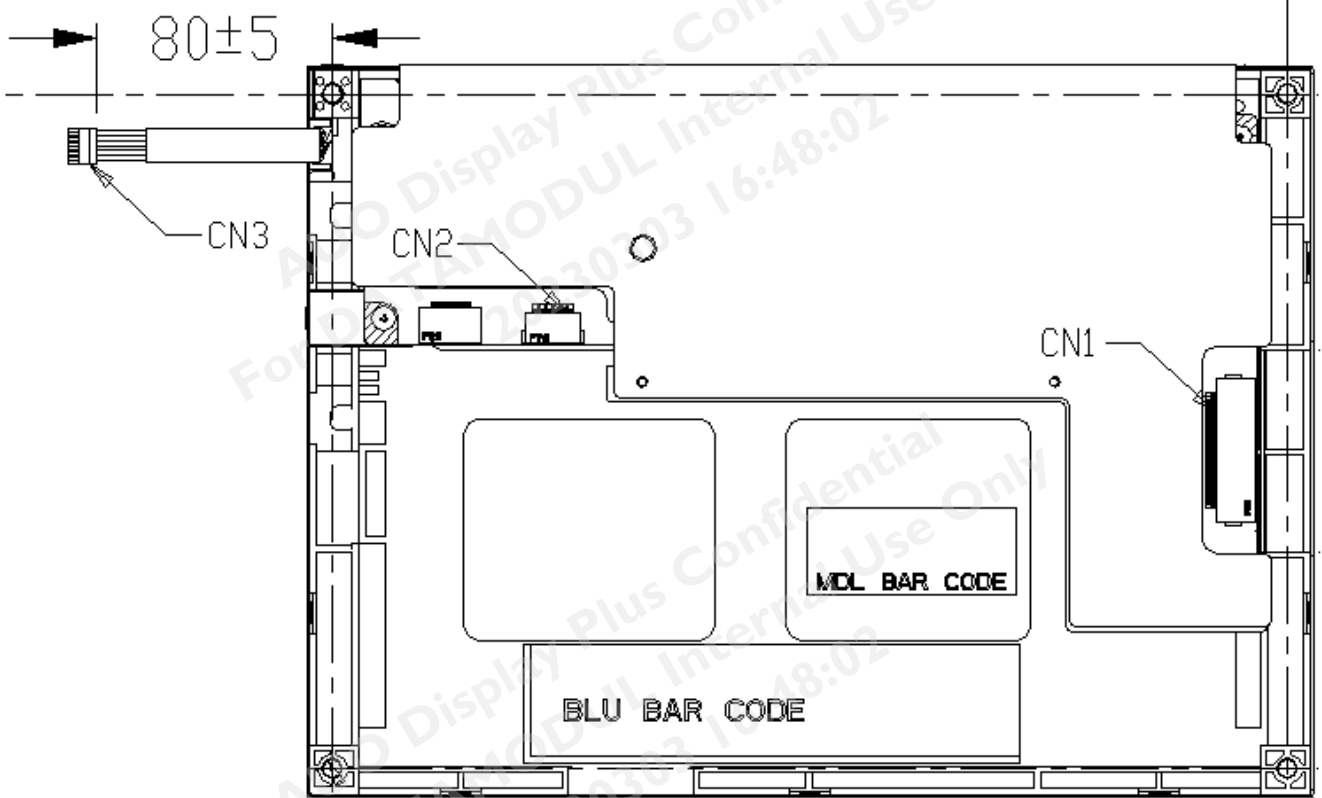

(Rear side of TFT-LCD)

8. Reliability Test Criteria

Items	Required Condition	Note
Temperature Humidity Bias	40°C/90%,300 hours	Note 2
High Temperature Operation	85°C,300 hours	Note 2
Low Temperature Operation	-30°C,300 hours	Note 2
Hot Storage	85°C,300 hours	Note 2
Cold Storage	-30°C,300 hours	Note 2
Thermal Shock Test	-20°C/30 min ,60°C/30 min ,100cycles	Note 2
Hot Start Test	85°C/1 Hr (min.), power on/off per 5 minutes, repeat 5 times	Note 2
Cold Start Test	-30°C/1 Hr (min.), power on/off per 5 minutes, repeat 5 times	Note 2
Shock Test (Non-Operating)	50G,20ms,Half-sine wave,(±X, ±Y, ±Z)	Note 2
Vibration Test (Non-Operating)	1.5G, (10~200Hz, P-P) 30 mins/axis (X, Y, Z)	Note 2
On/off test	On/10 sec, Off/10 sec, 30,000 cycles	Note 1,2
ESD	Contact Discharge:±8KV,150pF(330Ω)1sec,8 points,25 times/ point Air Discharge: ±15KV, 150pF(330Ω)1sec, 8 points, 25 times/ point	Note 2
Altitude Test	Operating: 14,000 ft, Ramp: 2000 ft/min, 8hrs Non-operating: 40,000 ft, Ramp: 2000 ft/min, 24hrs	Note 2

Note 1: According to EN61000-4-2, ESD class B: Some performance degradation allowed. No data lost
Self-recoverable. No hardware failures.

Note 2:

- Water condensation is not allowed for each test items.
- Each test is done by new TFT-LCD module. Don't use the same TFT-LCD module repeatedly for reliability test.
- The reliability test is performed only to examine the TFT-LCD module capability.
- To inspect TFT-LCD module after reliability test, please store it at room temperature and room humidity for 24 hours at least in advance.
- No function failure occurs.

9. Mechanical Characteristics

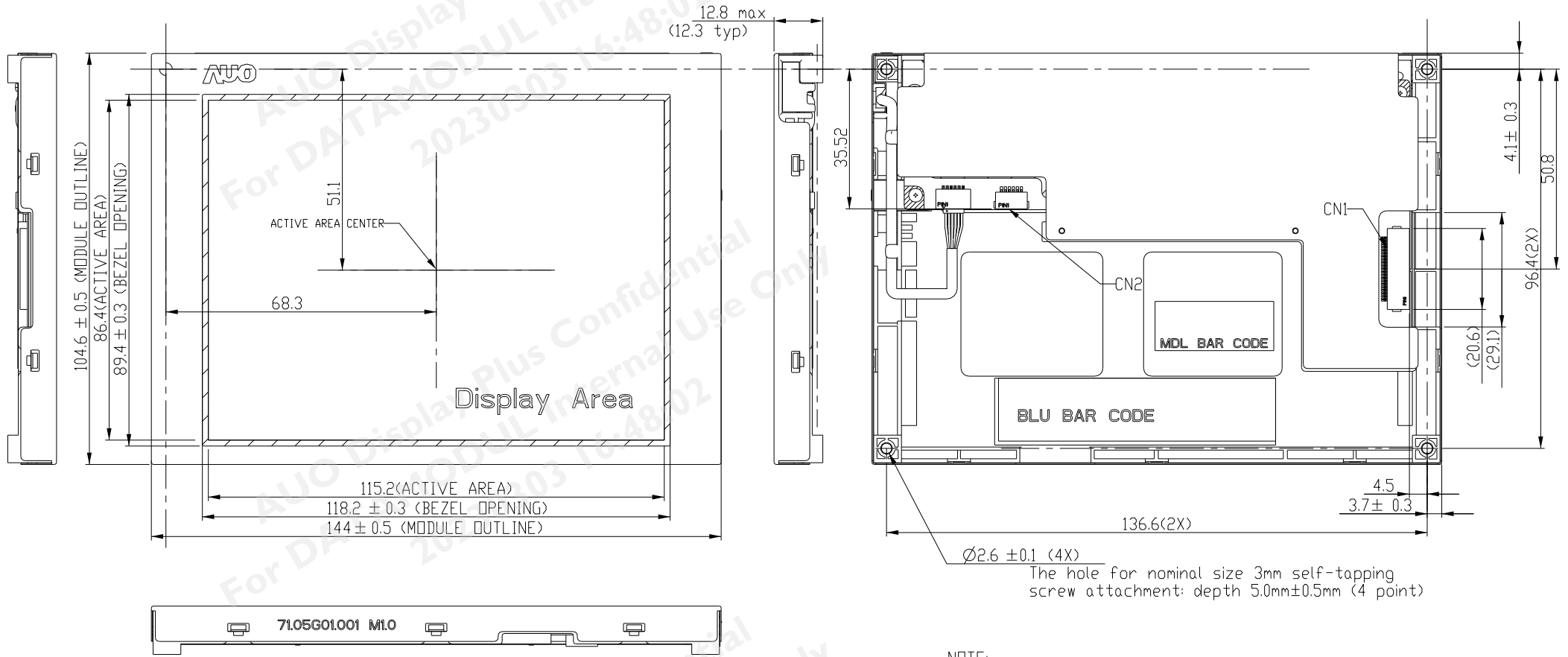

The hole for nominal size 3mm self-tapping screw attachment: depth 5.0mm±0.5mm (4 point)

- NOTE:
 1.CN1:I/F CONNCTOR IS 089H33-000100-G2-R (STARCONN)
 CN2:LED DRIVER CONNECTOR IS SM06B-SRKHFS(LF)(SN)(JST)
 2.TOLERANCE IS ±0.5 IF NOT SPECIFIED.

Note: Please evaluate the tightening torque according to customer's application.

10. Label and Packaging

10.1 Shipping Label (on the rear side of TFT-LCD display)

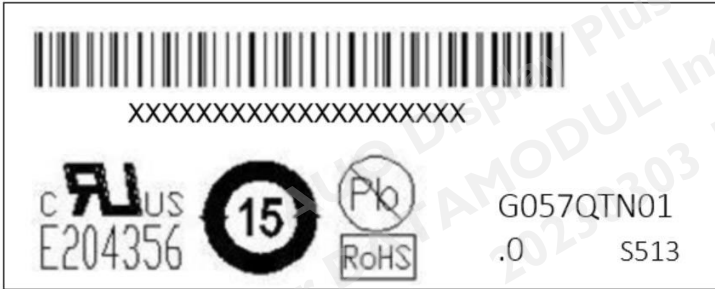

10.2 Carton Package

Max. capacity: 60 pieces TFT-LCD module per carton

Max. weight: 12.95 kg per carton

Outside dimension of carton: 520(L)mm* 340(W)mm* 250(H)mm

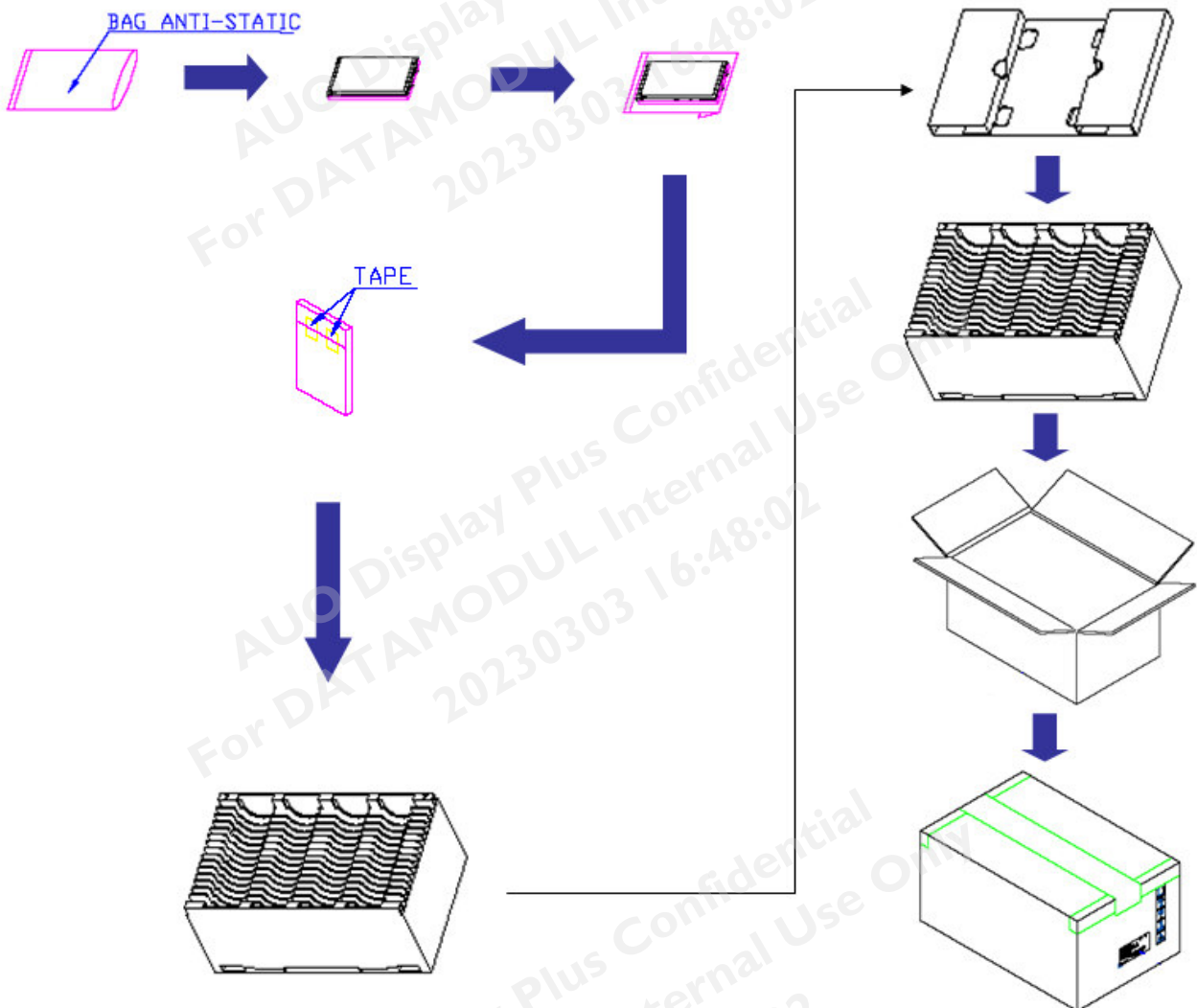

11 Safety

11.1 Sharp Edge Requirements

There will be no sharp edges or comers on the display assembly that could cause injury.

11.2 Materials

11.2.1 Toxicity

There will be no carcinogenic materials used anywhere in the display module. If toxic materials are used, they will be reviewed and approved by the responsible AUO toxicologist.

11.2.2 Flammability

All components including electrical components that do not meet the flammability grade UL94-V1 in the module will complete the flammability rating exception approval process.

The printed circuit board will be made from material rated 94-V1 or better. The actual UL flammability rating will be printed on the printed circuit board.

11.3 Capacitors

If any polarized capacitors are used in the display assembly, provisions will be made to keep them from being inserted backwards.

11.4 National Test Lab Requirement

The display module will satisfy all requirements for compliance to:

UL 60950-1, Second Edition

U.S.A. Information Technology Equipment



ALL TECHNOLOGIES. ALL COMPETENCIES. ONE SPECIALIST.



DATA MODUL AG
Landsberger Straße 322
DE-80687 Munich
Phone: +49-89-56017-0

DATA MODUL WEIKERSHEIM GMBH
Lindenstraße 8
DE-97990 Weikersheim
Phone: +49-7934-101-0

