



SPECIFICATION



G057VTN01.110

5.7" – VGA – RGB/TTL

Version: 0.0

Date: 22.08.2022

Note: This specification is subject to change without prior notice

- Preliminary Specification
- Final Specification

Module	5.7 Inch Color TFT-LCD
Model Name	G057VTN01.1 (97D05G03.110)

Customer	Date
_____	_____
Checked & Approved by	
_____	_____
<p>Note: This Specification is subject to change without notice.</p>	

Approved by	Date
LeaDer Feng	2022/08/22
Prepared by	
Dan Lin	2022/08/22
<p>General Display Business Division / AU Optonics corporation</p>	

Contents

1. Operating Precautions	4
2. General Description	5
2.1 Display Characteristics	5
2.2 Optical Characteristics.....	6
3. Functional Block Diagram	8
4. Absolute Maximum Ratings	9
4.1 Absolute Ratings	9
4.2 Absolute Ratings of Environment.....	9
5. Electrical Characteristics	10
5.1 TFT-LCD Driving	10
5.2 Backlight Unit Driving	11
6. Signal Characteristic	13
6.1 Pixel Format Image	13
6.2 Scanning Direction	13
6.3 The Input Data Format	14
6.4 TFT- LCD Interface Signal Description	15
6.5 TFT- LCD Interface Timing.....	17
6.6 LED Backlight Unit Interface Signal Description.....	18
6.7 Power ON/OFF Sequence	18
7. Connector & Pin Assignment.....	20
7.1 TFT- LCD Signal (CN1): LCD Connector	20
7.2 LED Backlight Unit (CN2): Backlight Connector.....	20
7.3 LED Light Bar Input (CN3): Light Bar Connector	21
7.4 PIN 1 definition of CN1 and CN2.....	22
7.5 PIN 1 definition of CN3.....	22
8. Reliability Test Criteria	23
9. Mechanical Characteristics	24
10. Label and Packaging	25
10.1 Shipping Label (on the rear side of TFT-LCD display).....	25
10.2 Carton Package.....	25
11 Safety.....	25
11.1 Keen Edge Requirements	26
11.2 Materials	26
11.3 Capacitors.....	26
11.4 National Test Lab Requirement.....	26

1. Operating Precautions

- 1) Display area (Polarizer) of TFT-LCD Module is easily to be damaged, please be cautious and not to scratch it.
- 2) Be sure to power off your machine before connecting or disconnecting your signal cable to TFT-LCD Module.
- 3) Wipe off water drop on display area immediately. Long contact with water may cause discoloration or spots.
- 4) When the panel surface is soiled, wipe it with absorbent cotton or soft cloth.
- 5) Display area (Glass) of TFT-LCD Module may be broken or cracked if bump Module against hard object.
- 6) To avoid ESD (Electro Static Discharge) damage, be sure to ground yourself before handling TFT-LCD Module.
- 7) Do not open nor modify the TFT-LCD module assembly.
- 8) Do not press the reflector sheet at the back of the module to any direction.
- 9) In case if TFT-LCD module has to be put back into the packing container slot after it was taken out from the container, do not press the center of the LED Reflector edge. Instead, press at the far ends of the LED Reflector edge softly. Otherwise the TFT-LCD Module may be damaged.
- 10) When inserting or removing of your signal cable to TFT-LCD Module, be sure not to apply abnormal force (rotate, tilt...etc.) to the Connector of the TFT-LCD Module.
- 11) TFT-LCD Module is not allowed to be twisted & bent even force is added on module in a very short time. Please design your display product well to avoid external force applying to module by end-user directly.
- 12) Small amount of materials without flammability grade are used in the TFT-LCD module. The TFT-LCD module should be supplied by power complied with requirements of Limited Power Source (IEC60950 or UL1950), or be applied exemption.
- 13) Severe temperature condition may result in different luminance, response time.
- 14) Continuous operating TFT-LCD Module under high temperature environment may accelerate LED light bar exhaustion and reduce luminance dramatically.
- 15) The data on this specification sheet is applicable when TFT-LCD module is placed in landscape position.
- 16) Continuous displaying fixed pattern may induce image sticking. It's recommended to use screen saver or moving content periodically if fixed pattern is displayed on the screen.

2. General Description

G057VTN01.1 is designed for industrial display applications with VGA (640 x RGB x 480) resolution and 262k colors (Digital 6-bits Parallel RGB interface). It is composed of a TFT-LCD panel, driver ICs, control and power supply circuits board and backlight unit including LED driver circuit.

2.1 Display Characteristics

The following items are G057VTN01.1 characteristics summary at 25 °C (Room Temperature).

Items	Unit	Specifications
Screen Diagonal	inch	5.7
Active Area	mm	115.2(H) x 86.4(V)
Pixels H x V	dots	640 x 3(RGB) x 480
Pixel Pitch	mm	0.18 x 0.18
Pixel Arrangement	—	R.G.B. Vertical Stripe
Display Mode	—	AHVA, Normally black
Nominal Input Voltage VDD	Volt	3.3 typ.
Typical Power Consumption	Watt	TBD
Weight	Grams	150g (typ.), 165g (max.)
Physical Size	mm	144.0(H)x 104.6(V) x 12.3(D) (typ.)
Electrical Interface	—	Digital 6-bit Parallel RGB
Surface Treatment	—	Anti-Glare, Hardness 3H
Support Color	—	262K colors
Temperature Range		
Operating	°C	-30 to +85
Storage (Non-Operating)	°C	-30 to +85
RoHS Compliance	—	RoHS Compliance

2.2 Optical Characteristics

The optical characteristics are measured under stable conditions at 25°C (Room Temperature).

Item	Unit	Conditions	Min.	Typ.	Max.	Remark
White Luminance	cd/m ²	V _{LED} = 12V, D _{PWM} = 100% (center point)	440	550	-	Note 1
Uniformity	%	5 Points	75	-	-	Note 1, 2, 3
Contrast Ratio			800	1000	-	Note 4
Response Time	msec	Rising	-	15	20	Note 5
	msec	Falling	-	10	15	
	msec	Rising + Falling	-	25	35	
Viewing Angle	degree	Horizontal (Right)	80	89	-	Note 6
	degree	CR = 10 (Left)	80	89	-	
	degree	Vertical (Upper)	80	89	-	
	degree	CR = 10 (Lower)	80	89	-	
Color / Chromaticity Coordinates (CIE 1931)		White x	0.263	0.313	0.363	
		White y	0.279	0.329	0.379	
		Red x		TBD		
		Red y		TBD		
		Green x		TBD		
		Green y		TBD		
		Blue x		TBD		
		Blue y		TBD		
Color Gamut	%		-	50	-	

Note 1: Measurement method

- Equipment: Pattern Generator, Power Supply, Digital Voltmeter, Luminance meter (SR_3 or equivalent)
- Aperture: 1° with 50cm viewing distance
- Test Point: Center
- Environment: < 1 lux

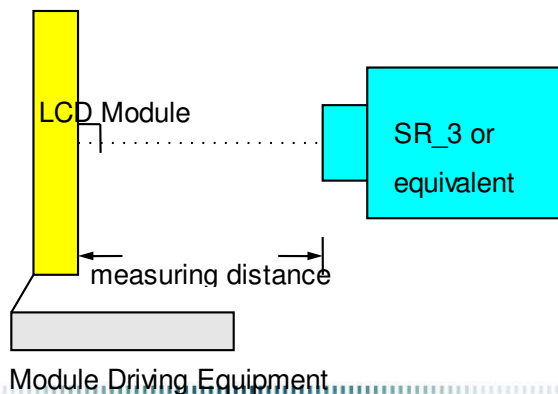

Note 2: Definition of 5 points position (Display active area: 115.2mm(W) x 86.4mm(H))

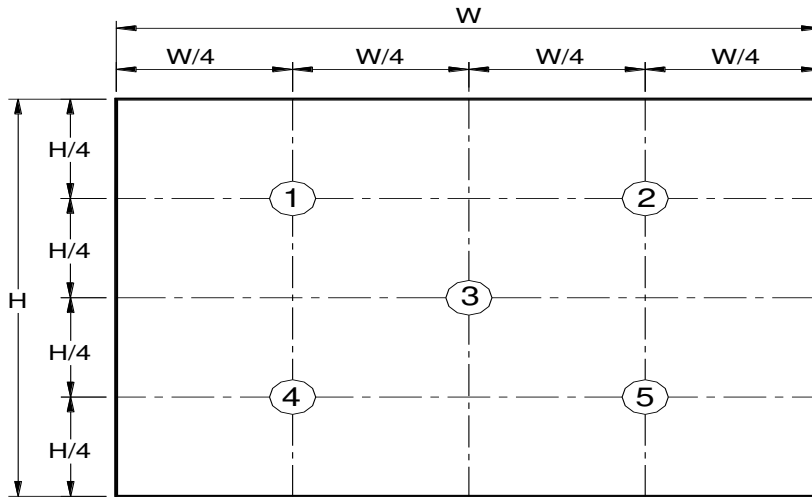

Note 3:

The luminance uniformity of 5 points is defined by dividing the minimum luminance value by the maximum luminance value at full white condition.

$$\delta_{w5} = \frac{\text{Minimum Brightness of 5 points}}{\text{Maximum Brightness of 5 points}}$$

Note 4: Definition of contrast ratio (CR):

$$\text{Contrast ratio (CR)} = \frac{\text{Brightness @ "White" state}}{\text{Brightness @ "Black" state}}$$

Note 5: Definition of response time:

The output signals of photo detector are measured when the input signals are changed from "White" to "Black" (falling time) and from "Black" to "White" (rising time), respectively. The response time interval definition is between 10% and 90% of amplitude. Please refer to the figure as below.

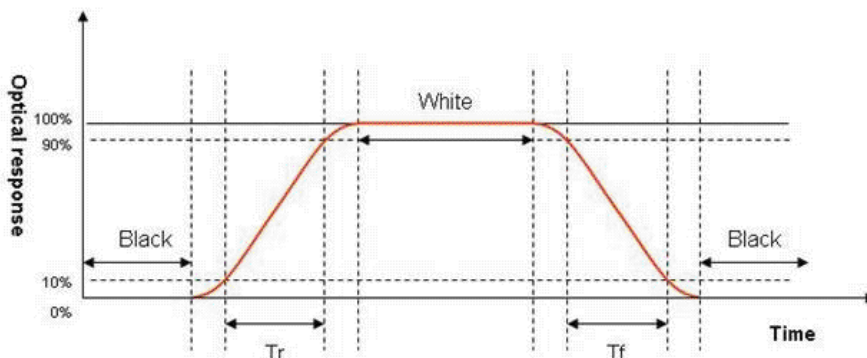

Note 6: Definition of viewing angle

Viewing angle is the measurement of contrast ratio ≥ 10 , at the screen center, over 180° horizontal and 180° vertical range. The 180° horizontal (θ_L, θ_R) and 180° vertical (ϕ_H, ϕ_L) range are illustrated as following figure.

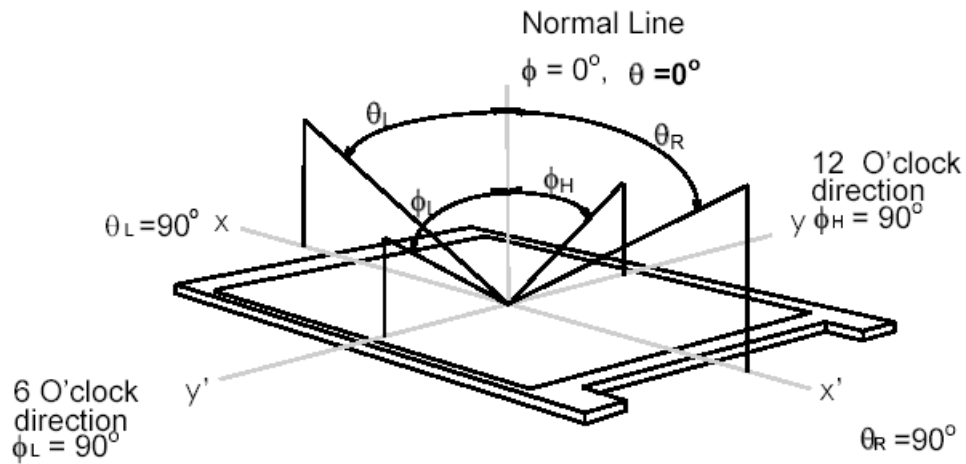

3. Functional Block Diagram

The following diagram shows the functional block of the G057VTN01.1 color TFT/LCD module.

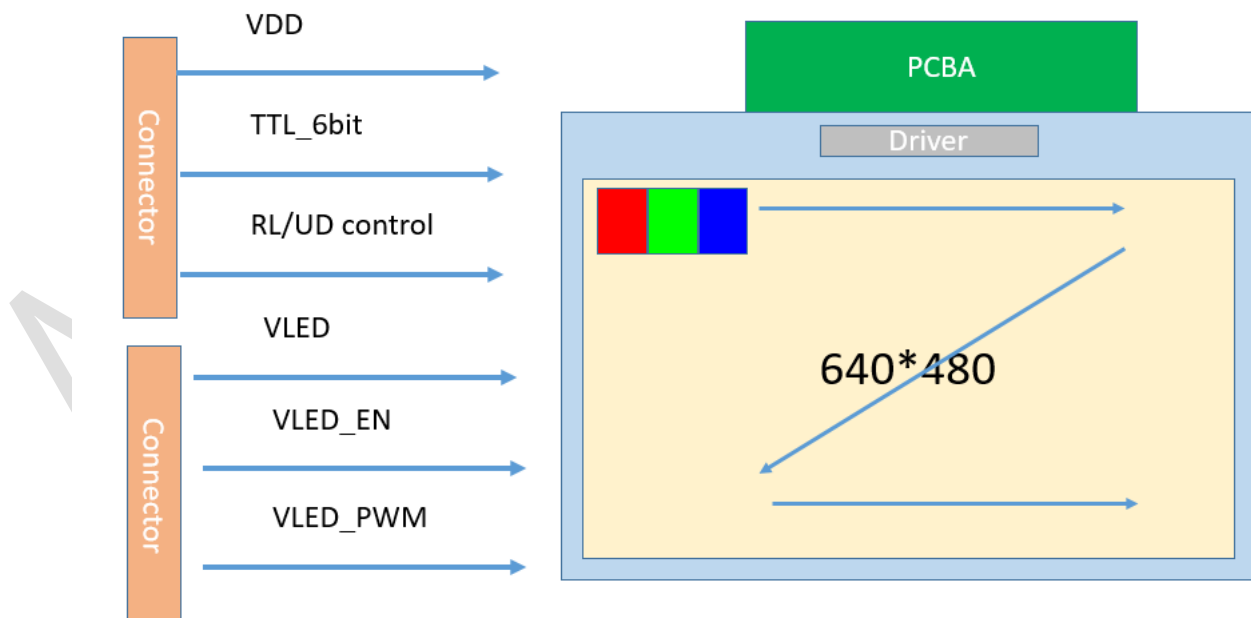

4. Absolute Maximum Ratings

4.1 Absolute Ratings

Item	Symbol	Min	Max	Unit	Remark
Logic/LCD Drive Voltage	VDD	- 0.3	+3.6	Volt	Ta= 25°C
LED BLU Drive Voltage	V _{LED}	0	23	Volt	Ta= 25°C
LED Dimming Input Voltage	VLED_PWM	0	VLED	Volt	Ta= 25°C

4.2 Absolute Ratings of Environment

Item	Symbol	Min	Max	Unit	Remark
Operating Temperature	TOP	-30	+85	°C	Note 1, 2
Operation Humidity	HOP	5	95	%RH	Note 1, 2
Storage Temperature	TST	-30	+85	°C	Note 1
Storage Humidity	HST	5	95	%RH	Note 1

Note 1: Maximum Wet-Bulb should be 39°C and no condensation.

Note 2: Only operation is guaranteed. Optical performance should be evaluated at 25°C only.

5. Electrical Characteristics

5.1 TFT-LCD Driving

5.1.1 Power Specification

Symbol	Parameter	Min	Typ	Max	Units	Remark
VDD	Logic/LCD Drive Voltage	3.0	3.3	3.5	Volt	
IDD	VDD Current	-	TBD	TBD	mA	All Black Pattern (VDD=3.3V, at 60Hz)
Irush	LCD Inrush Current	-	-	TBD	A	Note 1
PDD	VDD Power	-	TBD	TBD	Watt	All Black Pattern (VDD=3.3V, at 60Hz)
VDDrp	Allowable Logic/LCD Drive Ripple Voltage	-	-	TBD	mVp-p	All Black Pattern (VDD=3.3V, at 60Hz)

Note 1: Measurement condition:

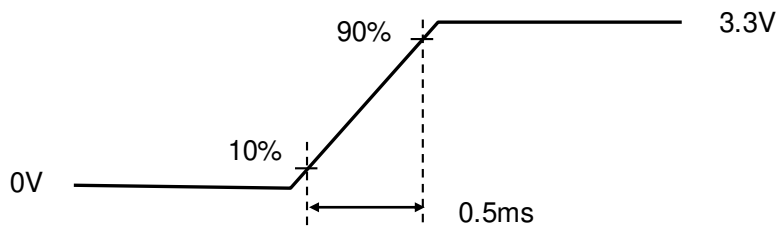
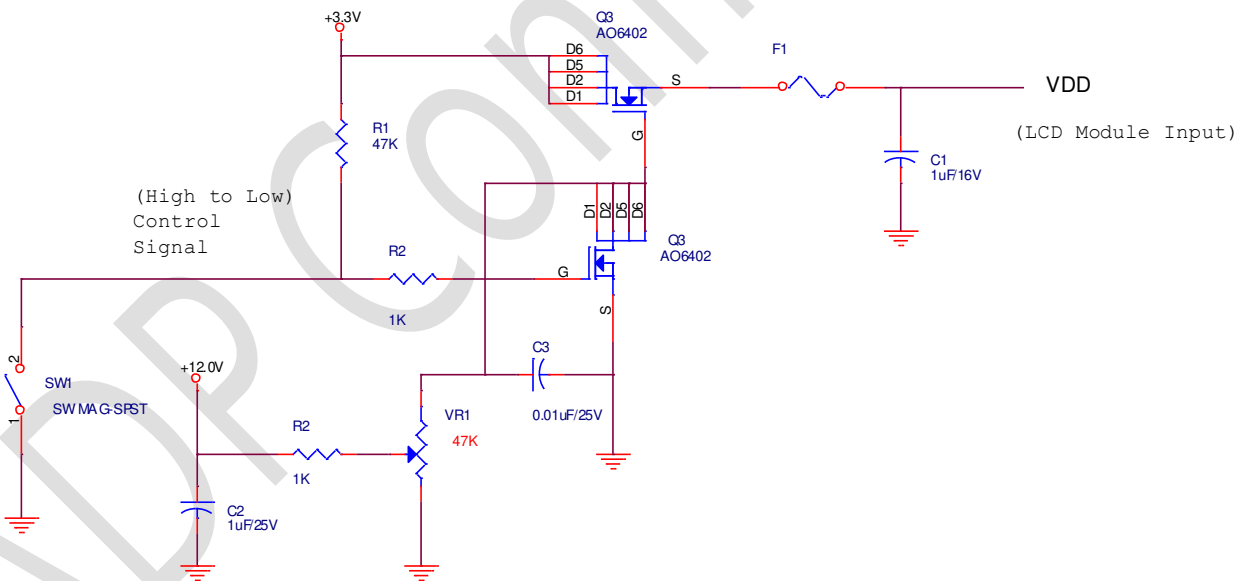

VDD rising time

5.1.2 Signal Electrical Characteristics

Input signals shall be low or Hi-Z state when VDD is off.

Parameter		Symbol	Min.	Typ.	Max.	Unit	Remarks
Logic Input Voltage for Display Signals	High	V _{IH}	0.7VDD	-	VDD	Volt	
	Low	V _{IL}	0	-	0.3VDD	Volt	
Input Voltage for RL/UD	High	V _{IH}	0.7VDD	-	VDD	Volt	
	Low	V _{IL}	0	-	0.3VDD	Volt	

5.2 Backlight Unit Driving

5.2.1 Parameter guideline for LED

Following characteristics are measured under stable condition using a LED driving board at 25°C (Room Temperature)

Symbol	Parameter	Min	Typ	Max	Units	Remark
V _{LED}	Input Voltage	9	12	20	Volt	
I _{LED}	Input Current	-	TBD	TBD	A	V _{LED} = 12V, D _{PWM} = 100%
P _{LED}	Power Consumption	-	TBD	TBD	Watt	V _{LED} = 12V, D _{PWM} = 100%
I _{rushVLED}	Inrush Current	-		TBD	A	V _{LED} = 12V, D _{PWM} = 100%
V _{LED_PWM}	Dimming control Voltage High	2.0	3.3	5.0	Volt	Note 1,2
	Dimming control Voltage Low	-	-	0.2	Volt	
F _{PWM}	Dimming Frequency	200		20K	Hz	
D _{PWM}	Dimming duty cycle	TBD		100	%	
V _{LED_EN}	On Control Voltage	2	3.3	5.5	Volt	Note 3, 4
	Off Control Voltage	-	-	0.8	Volt	
I _F	LED Forward Current		35		mA	Ta = 25oC
V _F	LED Forward Voltage	-	30	34	Volt	I _F = 35mA, Ta = 25oC
P _{LED}	LED Power		1.05	1.19	Watt	
Operating Life		70000	-	-	Hrs	Note 5, 6, 7

Note 1: PWM dimming function can be operated by PWM signal. PWM duty cycle can adjust white Luminance.
(PWM High: ON and PWM Low: OFF)

Note 2: PWM signal can not be floating and pull-down to ground when waiting.

Note 3: Enable ([VLED_EN](#)) must be turned on late than VLED and PWM Signal.

Note 4: Enable ([VLED_EN](#)) must be turned off early than VLED and PWM Signal.

Note 5: If G057VTN01.1 module is driven by high current or at high ambient temperature & humidity condition. The operating life will be reduced.

Note 6: Operating life means brightness goes down to 50% initial brightness. Minimum operating life time is estimated data.

Note 7: Test condition is 35mA of each LED and 25°C room temperature.

Note 8: See Section 6.6 for LED Backlight Unit Interface Signal Description

6. Signal Characteristic

6.1 Pixel Format Image

Following figure shows the relationship between input signal and LCD pixel format.

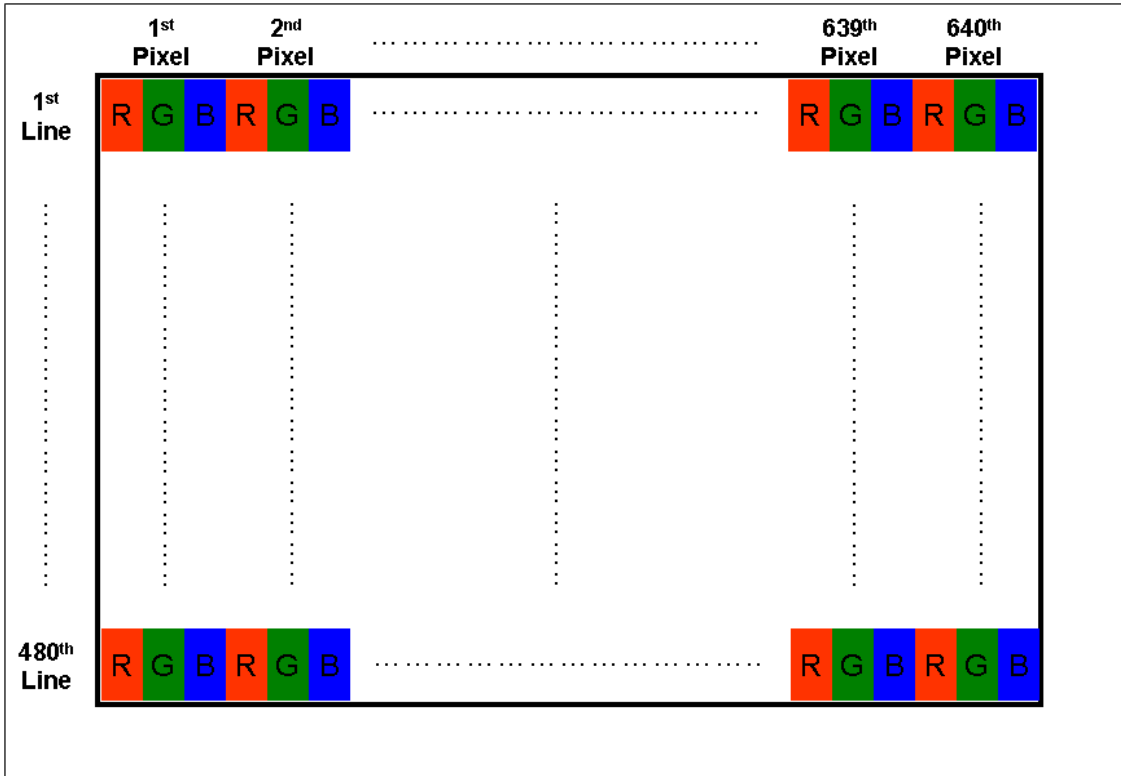

6.2 Scanning Direction

The following figures show the image seen from the front view. The arrow indicates the direction of scan.

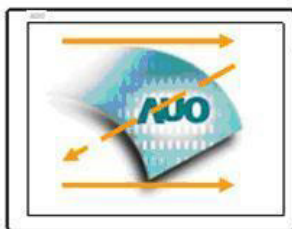

R/L=Low or NC; U/D=High or NC



R/L=High; U/D=High or NC



R/L=Low or NC; U/D=Low



R/L=High; U/D=Low

Note 1: TFT-LCD interface signal description is shown in section 6.4.

6.3 The Input Data Format

This product displays 262,144 colors in terms of the 64 grey levels on RGB respectively. The following table demonstrates the display of input data.

Display colors		Data signal (0 : Low level, 1: High level)																	
		R5	R4	R3	R2	R1	R0	G5	G4	G3	G2	G1	G0	B5	B4	B3	B2	B1	B0
Basic colors	Black	0	0	0	0	0	0	0	0	0	0	0	0	0	0	0	0	0	0
	Blue	0	0	0	0	0	0	0	0	0	0	0	0	1	1	1	1	1	1
	Red	1	1	1	1	1	1	0	0	0	0	0	0	0	0	0	0	0	0
	Magenta	1	1	1	1	1	1	0	0	0	0	0	0	1	1	1	1	1	1
	Green	0	0	0	0	0	0	1	1	1	1	1	1	0	0	0	0	0	0
	Cyan	0	0	0	0	0	0	1	1	1	1	1	1	1	1	1	1	1	1
	Yellow	1	1	1	1	1	1	1	1	1	1	1	1	0	0	0	0	0	0
	White	1	1	1	1	1	1	1	1	1	1	1	1	1	1	1	1	1	1
Red grayscale	Black	0	0	0	0	0	0	0	0	0	0	0	0	0	0	0	0	0	0
	Dark	0	0	0	0	1	0	0	0	0	0	0	0	0	0	0	0	0	0
	↑ ↓ bright																		
		1	1	1	1	0	1	0	0	0	0	0	0	0	0	0	0	0	0
		1	1	1	1	1	0	0	0	0	0	0	0	0	0	0	0	0	0
	Red	1	1	1	1	1	1	0	0	0	0	0	0	0	0	0	0	0	0
Green grayscale	Black	0	0	0	0	0	0	0	0	0	0	0	0	0	0	0	0	0	0
	Dark	0	0	0	0	0	0	0	0	0	0	1	0	0	0	0	0	0	0
	↑ ↓ bright																		
		0	0	0	0	0	0	1	1	1	1	0	1	0	0	0	0	0	0
		0	0	0	0	0	0	1	1	1	1	1	0	0	0	0	0	0	0
	Green	0	0	0	0	0	0	1	1	1	1	1	1	0	0	0	0	0	0
Blue grayscale	Black	0	0	0	0	0	0	0	0	0	0	0	0	0	0	0	0	0	0
	Dark	0	0	0	0	0	0	0	0	0	0	0	0	0	0	0	0	1	0
	↑ ↓ bright																		
		0	0	0	0	0	0	0	0	0	0	0	0	1	1	1	1	0	1
		0	0	0	0	0	0	0	0	0	0	0	0	1	1	1	1	1	0
	Blue	0	0	0	0	0	0	0	0	0	0	0	0	1	1	1	1	1	1

6.4 TFT- LCD Interface Signal Description

Pin#	Symbol	Pin Description
1	GND	Ground
2	CLK	Dot clock
3	NC	Reserved for internal test. Please treat it as no Connect.
4	NC	Reserved for internal test. Please treat it as no Connect.
5	GND	Ground
6	R0	Red data(LSB)
7	R1	Red data
8	R2	Red data
9	R3	Red data
10	R4	Red data
11	R5	Red data(MSB)
12	GND	Ground
13	G0	Green data(LSB)
14	G1	Green data
15	G2	Green data
16	G3	Green data
17	G4	Green data
18	G5	Green data(MSB)
19	GND	Ground
20	B0	Blue data(LSB)
21	B1	Blue data
22	B2	Blue data
23	B3	Blue data
24	B4	Blue data
25	B5	Blue data(MSB)
26	GND	Ground
27	DE	Data Enable signal
28	VDD	Power Supply
29	VDD	Power Supply
30	R/L	Horizontal scan Normal: L or NC, Reverse: H

31	U/D	Vertical scan Normal: H or NC, Reverse: L
32	NC	Reserved for internal test. Please treat it as no Connect.
33	GND	Ground

Note 1: "Low" stands for 0V. "High" stands for 3.3V. "NC" stands for "No Connection".

ADP Confidential

6.5 TFT- LCD Interface Timing

6.5.1 Timing Characteristics

DE mode only

Signal	Symbol	Min.	Typ.	Max.	Unit	Remark	
Clock frequency (DOTCLK)	$1/ T_{\text{CLOCK}}$	23.9	25.2	28.73	MHz	Note1	
Data	Setup Time	T_{dsu}	8		ns	RL, GL, BL to DCLK	
	Hold Time	T_{dhd}	8		ns		
DE	Setup Time	T_{esu}	8		ns		
Horizontal Section	Period	T_{H}	770	800	840	T_{CLOCK}	Note1
	Active	T_{HD}	640				
	Blanking	T_{HB}	130	160	200		
Vertical Section	Period	T_{V}	516	525	570	T_{LINE}	Note1
	Active	T_{VD}	480				
	Blanking	T_{VB}	36	45	90		

Note 1: Recommended frame rate is 60 Hz.

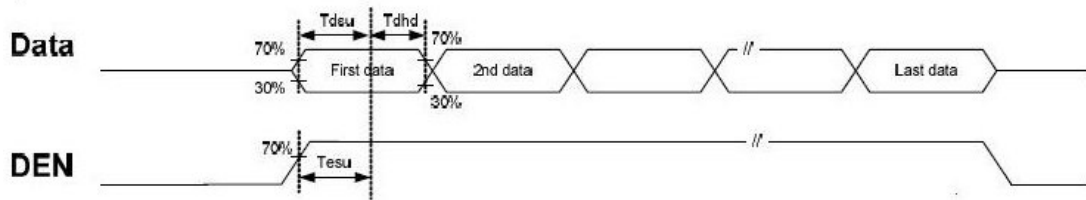

6.5.2 Input Timing Diagram

Input Timing Definition (DE Mode)

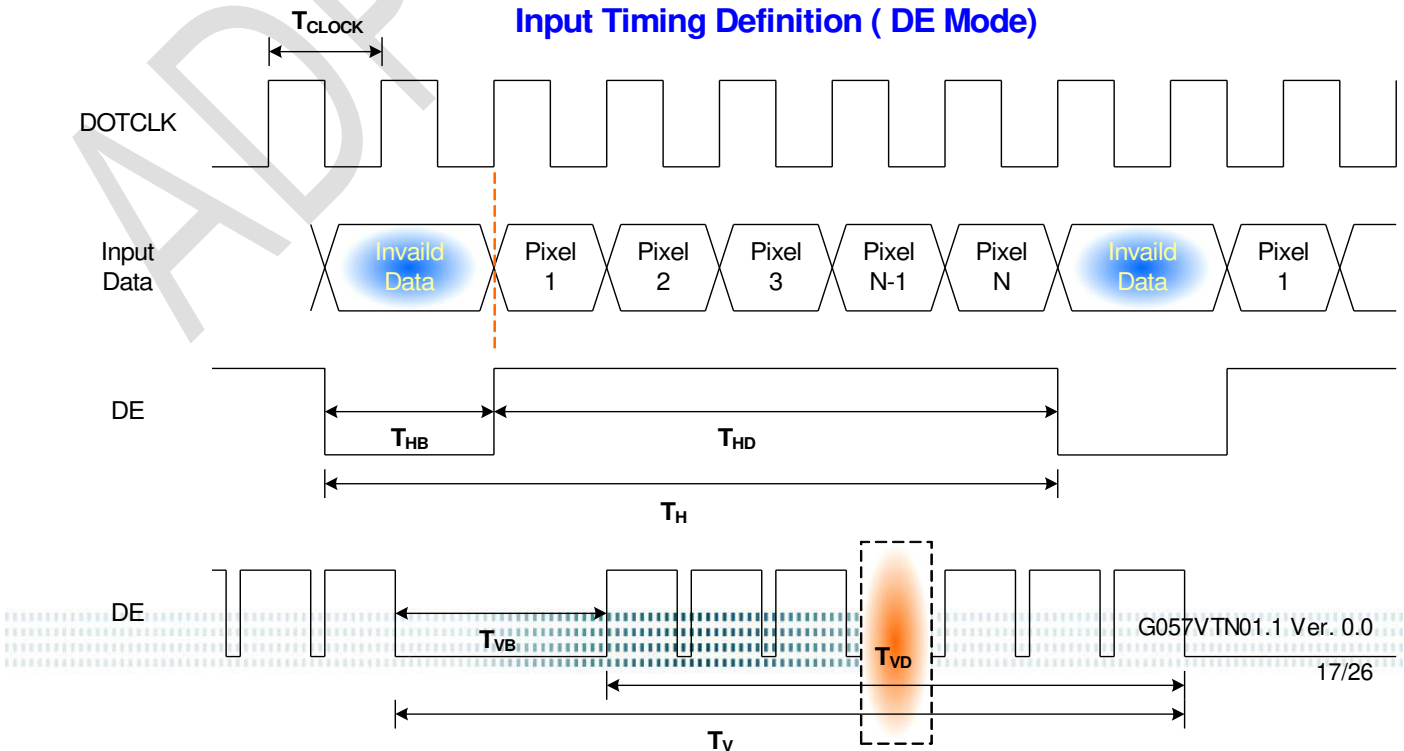

6.6 LED Backlight Unit Interface Signal Description

Pin #	Symbol	Pin Description
1	VLED	12V input
2	VLED	12V input
3	GND	Ground
4	GND	Ground
5	VLED_PWM	TBD
6	VLED_EN	0V-Off; 3.3~5V/NC-On

Note 1: "NC" stands for "No Connection"

6.7 Power ON/OFF Sequence

VDD power, LCD interface signals and backlight on/off sequence are shown in the following chart. Signals from any system shall be Hi-Z state or low level when VDD is off.

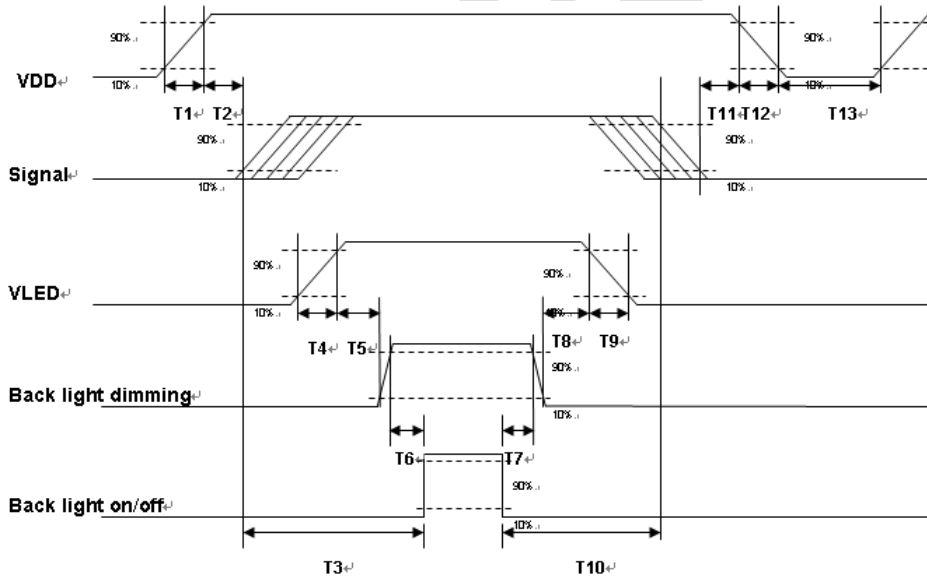

Power ON/OFF sequence timing

Parameter	Value			Units
	Min.	Typ.	Max.	
T1	0.5	--	10	[ms]
T2	TBD	--	200	[ms]
T3	TBD	--	--	[ms]
T4	10	--	--	[ms]
T5	50	--	--	[ms]
T6	0	--	--	[ms]

T7	0	--	--	[ms]
T8	TBD	--	--	[ms]
T9	0	TBD	TBD	[ms]
T10	TBD	--	--	[ms]
T11	2	--	--	[s]

ON/OFF sequence should be applied to avoid abnormal function in the display. Please make sure to turn off the power when you plug the cable into the input connector or pull the cable out of the connector.

ADP Confidential

7. Connector & Pin Assignment

7.1 TFT- LCD Signal (CN1): LCD Connector

Manufacturer	Starconn
Connector Model Number	089H33-000100-G2-R, compatible with IMSA-9637S-33Y902 & ELCO 08-6210--033-340-800+

Pin#	Symbol	Pin#	Symbol	Pin#	Symbol
1	GND	12	GND	23	B3
2	DOTCLK	13	G0	24	B4
3	NC	14	G1	25	B5
4	NC	15	G2	26	GND
5	GND	16	G3	27	DE
6	R0	17	G4	28	VDD
7	R1	18	G5	29	VDD
8	R2	19	GND	30	R/L
9	R3	20	B0	31	U/D
10	R4	21	B1	32	NC
11	R5	22	B2	33	GND

7.2 LED Backlight Unit (CN2): Backlight Connector

Manufacturer	JST
Connector Model Number	SM06B-SRKS-G-TB (HF)
Mating Connector Model Number	JST SHR-06V-BKHF-B or compatible

Pin #	Symbol	Pin #	Symbol
1	V _{LED}	4	GND
2	V _{LED}	5	PWM DIM
3	GND	6	LED ON/OFF

7.3 LED Light Bar Input (CN3): Light Bar Connector

Manufacturer	JST
Connector Model Number	SM06B-SHLK-GTF(HF)
Mating Connector Model Number	SM06B-SHLS-TF or compatible

Pin #	Symbol	Pin Description	Cable color
1	AN1	Channel 1 LED anode	Red
2	AN2	Channel 2 LED anode	Red
3	AN3	Channel 3 LED anode	Red
4	CA1	Channel 1 LED cathode	White
5	CA2	Channel 2 LED cathode	Blue
6	CA3	Channel 3 LED cathode	Black

7.4 PIN 1 definition of CN1 and CN2

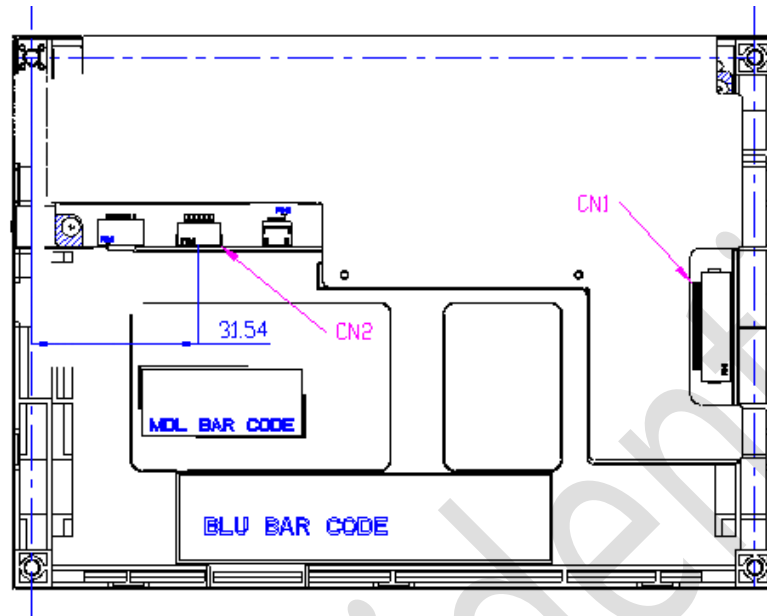

(Rear side of TFT-LCD)

7.5 PIN 1 definition of CN3

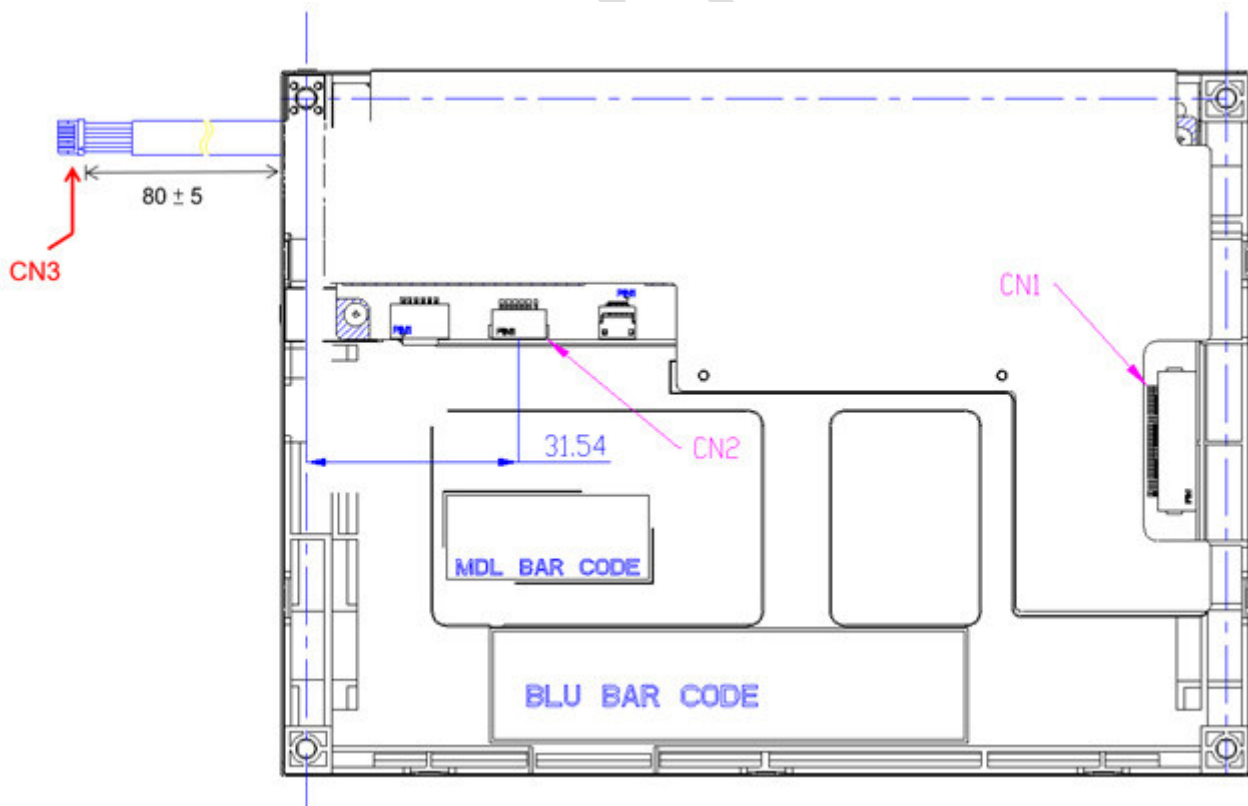

8. Reliability Test Criteria

Items	Required Condition	Remark
Temperature Humidity Bias	40°C /90%,300Hr	Note 2
High Temperature Operation	85°C ,300Hr	Note 2
Low Temperature Operation	-30°C ,300Hr	Note 2
High Temperature Storage	85°C ,300 hours	Note 2
Low Temperature Storage	-30°C ,300 hours	Note 2
Thermal Shock Test	-20°C /30 min ,60°C /30 min ,100cycles	Note 2
Hot Start Test	85°C /1 Hr (min.), power on/off per 5 minutes, repeat 5 times	Note 2
Cold Start Test	-30°C /1 Hr (min.), power on/off per 5 minutes, repeat 5 times	Note 2
Shock Test (Non-Operating)	50G,20ms,Half-sine wave, (±X, ±Y, ±Z)	Note 2
Vibration Test (Non-Operating)	Sine wave : 1.5G, 10~200~10Hz/Sine wave, 30mins/axis	Note 2
ESD	Contact Discharge: ±8KV, 150pF(330Ω) 1sec, 8 points, 25 times/point Air Discharge: ±15KV, 150pF(330Ω) 1sec, 8 points, 25 times/point	Note 1,2
Attitude Test	Operating: 14,000 ft, Ramp: 2000 ft/min, 8hrs Non-operating: 40,000 ft, Ramp: 2000 ft/min, 24hrs	Note 2

Note1: According to EN61000-4-2 ESD class B criteria, some performance degradation is allowed.

TFT-LCD module

is self-recoverable, no data lost and no hardware failures after test.

Note2:

- Water condensation is not allowed for each test items.
- Each test is done by new TFT-LCD module. Don't use the same TFT-LCD module repeatedly for reliability test.
- The reliability test is performed only to examine the TFT-LCD module capability.
- To inspect TFT-LCD module after reliability test, please store it at room temperature and room humidity for 24 hours at least in advance.

9. Mechanical Characteristics

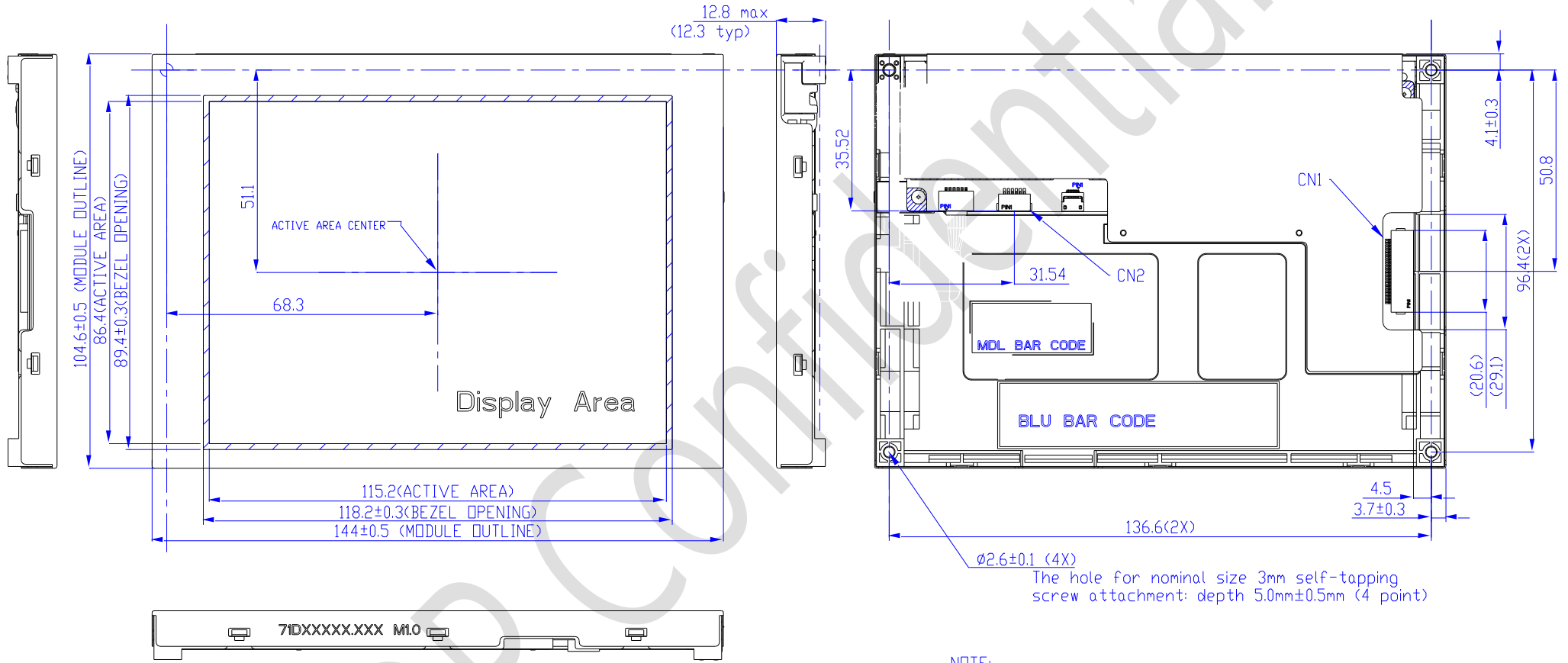

NOTE:
1. CN1: I/F CONNECTOR IS 089H33-000100-G2-R (STARCONN)
CN2: LED DRIVER CONNECTOR IS SM06B-SRKHFS(LF)(SN)(JST)
2. TOLERANCE IS ± 0.5 IF NOT SPECIFIED.

Note : Please evaluate the tightening torque according to customer's application.

10. Label and Packaging

10.1 Shipping Label (on the rear side of TFT-LCD display)

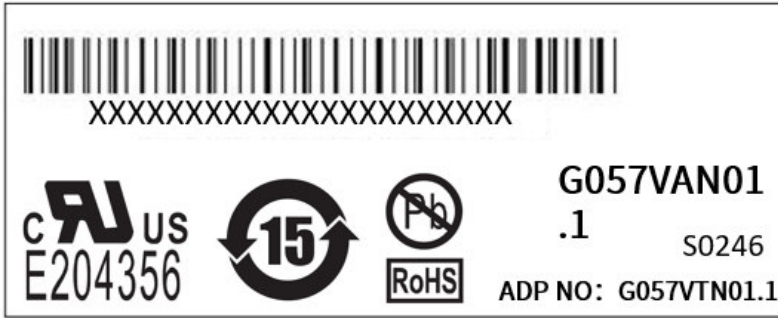

10.2 Carton Package

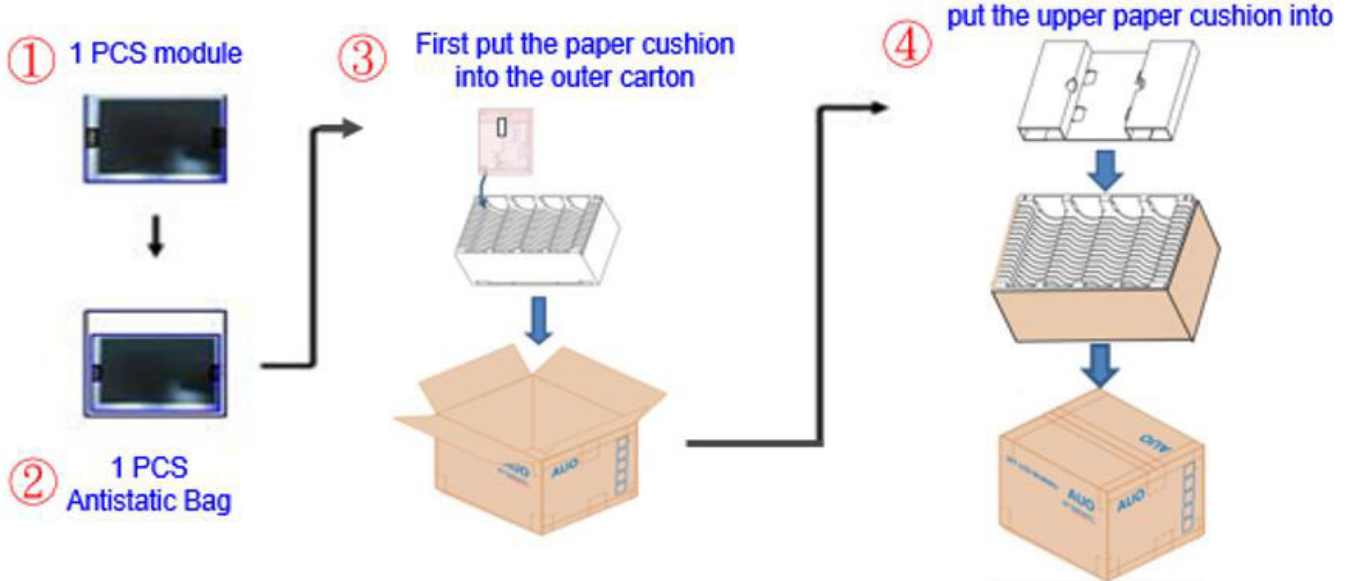

	<p>Total 60 pcs Module/carton</p> <p>Max. weight: 12.95 kg per carton</p> <p>Carton : 528mm*348mm 265mm</p> <p>pallet size: 1070 x1070 x 135 mm, pallet Model name : AU</p> <p>Box stacked : (3 * 2) * 5 layers, one pallet put 30 boxes, Total 1800 pcs module.</p>
--	--

11 Safety

11.1 Keen Edge Requirements

There will be no keen edges or corners on the display assembly that could cause injury.

11.2 Materials

11.2.1 Toxicity

There will be no carcinogenic materials used anywhere in the TFT-LCD module. If toxic materials are used, they will be reviewed and approved by the responsible AUO toxicologist.

11.2.2 Flammability

All components including electrical components that do not meet the flammability grade UL94-V1 in the TFT-LCD Module will complete the flammability rating exception approval process.

The printed circuit board will be made from material rated 94-V1 or better. The actual UL flammability rating will be printed on the printed circuit board.

11.3 Capacitors

If any polarized capacitors are used in the TFT-LCD module, provisions will be made to keep them from being inserted backwards.

11.4 National Test Lab Requirement

The TFT-LCD Module will satisfy all requirements for compliance to UL 60950 (U.S.A. Information Technology Equipment).



ALL TECHNOLOGIES. ALL COMPETENCIES. ONE SPECIALIST.

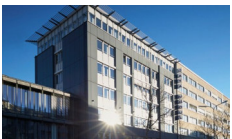

DATA MODUL AG
Landsberger Straße 322
DE-80687 Munich
Phone: +49-89-56017-0

DATA MODUL WEIKERSHEIM GMBH
Lindenstraße 8
DE-97990 Weikersheim
Phone: +49-7934-101-0



More information and worldwide locations can be found at

www.data-modul.com