



# SPECIFICATION

---



**G070VW01 V012**

**7" - WVGA – LVDS**

Version: 1.0

Date: 15.06.2023

Note: This specification is subject to change without prior notice



AUO Display+

# Product Specification

G070VW01.0

Preliminary Specification

Final Specification

<b>Module</b>	7.0 Inch Color TFT-LCD
<b>Model Name</b>	G070VW01.0 (97D07G01.012)

<b>Company</b>	
<hr/>	
<b>Checked &amp; Approved by</b>	<b>Date</b>
<hr/>	<hr/>

<b>Approved by</b>	<b>Date</b>
<hr/> Danny Liao	<hr/> 2023/06/15
<b>Prepared by</b>	
<hr/> Danny Liao	<hr/> 2023/06/15
General Display Business Unit / AUO Display Plus Corporation	



## Contents

<b>1. Operating Precautions .....</b>	<b>5</b>
<b>2. General Description.....</b>	<b>6</b>
2.1 Display Characteristics .....	6
2.2 Optical Characteristics .....	7
<b>3. Functional Block Diagram.....</b>	<b>10</b>
<b>4. Absolute Maximum Ratings .....</b>	<b>11</b>
4.1 Absolute Ratings of TFT LCD Module .....	11
4.2 Absolute Ratings of Environment .....	11
<b>5. Electrical Characteristics .....</b>	<b>12</b>
5.1 TFT LCD Module .....	12
5.2 Backlight Unit .....	14
<b>6. Signal Characteristic .....</b>	<b>15</b>
6.1 Pixel Format Image .....	15
6.2 Signal Description .....	16
6.3 Scanning Direction .....	17
6.4 The Input Data Format .....	18
6.5 Interface Timing.....	19
6.6 Power ON/OFF Sequence .....	20
<b>7. Connector &amp; Pin Assignment.....</b>	<b>21</b>
7.1 TFT LCD Signal (CN1): LVDS Connector .....	21
7.2 LED Backlight Unit (CN2): LED Driver Connector .....	21
7.3 LED Light Bar Input Connector (CN4): .....	22
<b>8. Reliability Test Criteria .....</b>	<b>22</b>
<b>9. Mechanical Characteristics.....</b>	<b>23</b>
9.1 LCM Front View.....	23
9.2 LCM Rear View .....	23
<b>10. Label and Packaging .....</b>	<b>24</b>
10.1 Shipping Label (on the rear side of TFT-LCD display) .....	24
10.2 Carton Package .....	24
11.1 Keen Edge Requirements .....	26
11.2 Materials .....	26
11.3 Capacitors .....	26
11.4 International Safety Standard Compliance .....	26

## Record of Revision

Version and Date	Page	Old description	New Description	Remark																																																																																																																																																																																																																		
0.0 2022/09/27	All	First edition																																																																																																																																																																																																																				
0.1 2022/10/31	All	Model name: G070VW01 V0	Model name: G070VW01.0																																																																																																																																																																																																																			
0.2 2022/12/08	24	TBD	Update shipping label <b>10.1 Shipping Label</b> (on the rear side of TFT-LCD display)- 																																																																																																																																																																																																																			
0.3 2023/01/11	6	Typical Power Consumption- [Watt]- TBD-	Typical Power Consumption- [Watt]- 2.68 tp-																																																																																																																																																																																																																			
	7	<table border="1"> <tr><td>Red x<sub>v</sub></td><td>TBD</td><td>TBD</td><td>TBD</td></tr> <tr><td>Red y<sub>v</sub></td><td>TBD</td><td>TBD</td><td>TBD</td></tr> <tr><td>Green x<sub>v</sub></td><td>TBD</td><td>TBD</td><td>TBD</td></tr> <tr><td>Green y<sub>v</sub></td><td>TBD</td><td>TBD</td><td>TBD</td></tr> <tr><td>Blue x<sub>v</sub></td><td>TBD</td><td>TBD</td><td>TBD</td></tr> <tr><td>Blue y<sub>v</sub></td><td>TBD</td><td>TBD</td><td>TBD</td></tr> <tr><td>White x<sub>v</sub></td><td>0.26</td><td>0.31</td><td>0.36</td></tr> <tr><td>White y<sub>v</sub></td><td>0.26</td><td>0.33</td><td>0.38</td></tr> </table>	Red x <sub>v</sub>	TBD	TBD	TBD	Red y <sub>v</sub>	TBD	TBD	TBD	Green x <sub>v</sub>	TBD	TBD	TBD	Green y <sub>v</sub>	TBD	TBD	TBD	Blue x <sub>v</sub>	TBD	TBD	TBD	Blue y <sub>v</sub>	TBD	TBD	TBD	White x <sub>v</sub>	0.26	0.31	0.36	White y <sub>v</sub>	0.26	0.33	0.38	<table border="1"> <tr><td>Red x<sub>v</sub></td><td>(0.573)</td><td>(0.629)</td><td>(0.673)</td></tr> <tr><td>Red y<sub>v</sub></td><td>(0.311)</td><td>(0.361)</td><td>(0.411)</td></tr> <tr><td>Green x<sub>v</sub></td><td>(0.276)</td><td>(0.326)</td><td>(0.376)</td></tr> <tr><td>Green y<sub>v</sub></td><td>(0.539)</td><td>(0.589)</td><td>(0.639)</td></tr> <tr><td>Blue x<sub>v</sub></td><td>(0.097)</td><td>(0.147)</td><td>(0.197)</td></tr> <tr><td>Blue y<sub>v</sub></td><td>(0.611)</td><td>(0.661)</td><td>(0.711)</td></tr> <tr><td>White x<sub>v</sub></td><td>0.26</td><td>0.31</td><td>0.36</td></tr> <tr><td>White y<sub>v</sub></td><td>0.28</td><td>0.33</td><td>0.38</td></tr> </table>	Red x <sub>v</sub>	(0.573)	(0.629)	(0.673)	Red y <sub>v</sub>	(0.311)	(0.361)	(0.411)	Green x <sub>v</sub>	(0.276)	(0.326)	(0.376)	Green y <sub>v</sub>	(0.539)	(0.589)	(0.639)	Blue x <sub>v</sub>	(0.097)	(0.147)	(0.197)	Blue y <sub>v</sub>	(0.611)	(0.661)	(0.711)	White x <sub>v</sub>	0.26	0.31	0.36	White y <sub>v</sub>	0.28	0.33	0.38																																																																																																																																																			
Red x <sub>v</sub>	TBD	TBD	TBD																																																																																																																																																																																																																			
Red y <sub>v</sub>	TBD	TBD	TBD																																																																																																																																																																																																																			
Green x <sub>v</sub>	TBD	TBD	TBD																																																																																																																																																																																																																			
Green y <sub>v</sub>	TBD	TBD	TBD																																																																																																																																																																																																																			
Blue x <sub>v</sub>	TBD	TBD	TBD																																																																																																																																																																																																																			
Blue y <sub>v</sub>	TBD	TBD	TBD																																																																																																																																																																																																																			
White x <sub>v</sub>	0.26	0.31	0.36																																																																																																																																																																																																																			
White y <sub>v</sub>	0.26	0.33	0.38																																																																																																																																																																																																																			
Red x <sub>v</sub>	(0.573)	(0.629)	(0.673)																																																																																																																																																																																																																			
Red y <sub>v</sub>	(0.311)	(0.361)	(0.411)																																																																																																																																																																																																																			
Green x <sub>v</sub>	(0.276)	(0.326)	(0.376)																																																																																																																																																																																																																			
Green y <sub>v</sub>	(0.539)	(0.589)	(0.639)																																																																																																																																																																																																																			
Blue x <sub>v</sub>	(0.097)	(0.147)	(0.197)																																																																																																																																																																																																																			
Blue y <sub>v</sub>	(0.611)	(0.661)	(0.711)																																																																																																																																																																																																																			
White x <sub>v</sub>	0.26	0.31	0.36																																																																																																																																																																																																																			
White y <sub>v</sub>	0.28	0.33	0.38																																																																																																																																																																																																																			
	12	<b>5.1.1 Power Specification</b> <table border="1"> <thead> <tr> <th>Symbol</th> <th>Parameter</th> <th>Min.</th> <th>Typ.</th> <th>Max.</th> <th>Units</th> <th>Remark</th> </tr> </thead> <tbody> <tr> <td>VDD</td> <td>Logic/LCD Drive Voltage</td> <td>3.0</td> <td>3.3</td> <td>3.6</td> <td>[Volt]</td> <td>±10%</td> </tr> <tr> <td>I<sub>VDD</sub></td> <td>VDD Current</td> <td>--</td> <td>TBD</td> <td>TBD</td> <td>[mA]</td> <td>64 Gray Bar Pattern - (VDD=3.3V, at 60Hz)</td> </tr> <tr> <td>I<sub>insh</sub></td> <td>LCD Inrush Current</td> <td>--</td> <td>--</td> <td>TBD</td> <td>[A]</td> <td>Note 1.</td> </tr> <tr> <td>P<sub>VDD</sub></td> <td>VDD Power</td> <td>--</td> <td>TBD</td> <td>TBD</td> <td>[Watt]</td> <td>64 Gray Bar Pattern - (VDD=3.3V, at 60Hz)</td> </tr> </tbody> </table>	Symbol	Parameter	Min.	Typ.	Max.	Units	Remark	VDD	Logic/LCD Drive Voltage	3.0	3.3	3.6	[Volt]	±10%	I <sub>VDD</sub>	VDD Current	--	TBD	TBD	[mA]	64 Gray Bar Pattern - (VDD=3.3V, at 60Hz)	I <sub>insh</sub>	LCD Inrush Current	--	--	TBD	[A]	Note 1.	P <sub>VDD</sub>	VDD Power	--	TBD	TBD	[Watt]	64 Gray Bar Pattern - (VDD=3.3V, at 60Hz)	<b>5.1.1 Power Specification</b> <table border="1"> <thead> <tr> <th>Symbol</th> <th>Parameter</th> <th>Min.</th> <th>Typ.</th> <th>Max.</th> <th>Units</th> <th>Remark</th> </tr> </thead> <tbody> <tr> <td>VDD</td> <td>Logic/LCD Drive Voltage</td> <td>3.0</td> <td>3.3</td> <td>3.6</td> <td>[Volt]</td> <td>±10%</td> </tr> <tr> <td>I<sub>VDD</sub></td> <td>VDD Current</td> <td>--</td> <td>230</td> <td>250</td> <td>[mA]</td> <td>64 Gray Bar Pattern - (VDD=3.3V, at 60Hz)</td> </tr> <tr> <td>I<sub>insh</sub></td> <td>LCD Inrush Current</td> <td>--</td> <td>--</td> <td>3</td> <td>[A]</td> <td>Note 1.</td> </tr> <tr> <td>P<sub>VDD</sub></td> <td>VDD Power</td> <td>--</td> <td>0.76</td> <td>0.9</td> <td>[Watt]</td> <td>64 Gray Bar Pattern - (VDD=3.3V, at 60Hz)</td> </tr> </tbody> </table>	Symbol	Parameter	Min.	Typ.	Max.	Units	Remark	VDD	Logic/LCD Drive Voltage	3.0	3.3	3.6	[Volt]	±10%	I <sub>VDD</sub>	VDD Current	--	230	250	[mA]	64 Gray Bar Pattern - (VDD=3.3V, at 60Hz)	I <sub>insh</sub>	LCD Inrush Current	--	--	3	[A]	Note 1.	P <sub>VDD</sub>	VDD Power	--	0.76	0.9	[Watt]	64 Gray Bar Pattern - (VDD=3.3V, at 60Hz)																																																																																																																																													
Symbol	Parameter	Min.	Typ.	Max.	Units	Remark																																																																																																																																																																																																																
VDD	Logic/LCD Drive Voltage	3.0	3.3	3.6	[Volt]	±10%																																																																																																																																																																																																																
I <sub>VDD</sub>	VDD Current	--	TBD	TBD	[mA]	64 Gray Bar Pattern - (VDD=3.3V, at 60Hz)																																																																																																																																																																																																																
I <sub>insh</sub>	LCD Inrush Current	--	--	TBD	[A]	Note 1.																																																																																																																																																																																																																
P <sub>VDD</sub>	VDD Power	--	TBD	TBD	[Watt]	64 Gray Bar Pattern - (VDD=3.3V, at 60Hz)																																																																																																																																																																																																																
Symbol	Parameter	Min.	Typ.	Max.	Units	Remark																																																																																																																																																																																																																
VDD	Logic/LCD Drive Voltage	3.0	3.3	3.6	[Volt]	±10%																																																																																																																																																																																																																
I <sub>VDD</sub>	VDD Current	--	230	250	[mA]	64 Gray Bar Pattern - (VDD=3.3V, at 60Hz)																																																																																																																																																																																																																
I <sub>insh</sub>	LCD Inrush Current	--	--	3	[A]	Note 1.																																																																																																																																																																																																																
P <sub>VDD</sub>	VDD Power	--	0.76	0.9	[Watt]	64 Gray Bar Pattern - (VDD=3.3V, at 60Hz)																																																																																																																																																																																																																
	14	<b>5.2.1 Parameter guideline for LED</b> Following characteristics are measured under a stable condition using an inverter at 25°C (Room Temperature):- <table border="1"> <thead> <tr> <th>Symbol</th> <th>Parameter</th> <th>Min.</th> <th>Typ.</th> <th>Max.</th> <th>Unit</th> <th>Remark</th> </tr> </thead> <tbody> <tr> <td>VCC</td> <td>Input Voltage</td> <td>10.8</td> <td>12</td> <td>12.6</td> <td>[Volt]</td> <td>--</td> </tr> <tr> <td>I<sub>insh</sub></td> <td>Input Current</td> <td>--</td> <td>TBD</td> <td>--</td> <td>[A]</td> <td>100% analog dimming</td> </tr> <tr> <td>P<sub>VCC</sub></td> <td>Power Consumption</td> <td>--</td> <td>TBD</td> <td>TBD</td> <td>[Watt]</td> <td>100% analog dimming</td> </tr> <tr> <td>I<sub>insh LED</sub></td> <td>Inrush Current</td> <td>--</td> <td>--</td> <td>TBD</td> <td>[A]</td> <td>at rising time=470us</td> </tr> <tr> <td>Dimming</td> <td>Swing Voltage</td> <td>0.3</td> <td>--</td> <td>5.0</td> <td>V</td> <td>Analog Dimming</td> </tr> <tr> <td>Display ON/OFF</td> <td>On Control Voltage</td> <td>2</td> <td>3.3</td> <td>5</td> <td>[Volt]</td> <td>--</td> </tr> <tr> <td></td> <td>Off Control Voltage</td> <td>--</td> <td>0</td> <td>0.6</td> <td>[Volt]</td> <td>--</td> </tr> <tr> <td></td> <td>Brightness percentage</td> <td>25</td> <td>--</td> <td>100</td> <td>%</td> <td>--</td> </tr> <tr> <td>I<sub>f</sub></td> <td>LED Forward Current</td> <td>--</td> <td>TBD</td> <td>TBD</td> <td>mA</td> <td>Ta=25°C</td> </tr> <tr> <td></td> <td></td> <td>--</td> <td>TBD</td> <td>--</td> <td>[Volt]</td> <td>I<sub>f</sub>=50mA, Ta=-30°C</td> </tr> <tr> <td>V<sub>f</sub></td> <td>LED Forward Voltage</td> <td>--</td> <td>TBD</td> <td>TBD</td> <td>[Volt]</td> <td>I<sub>f</sub>=50mA, Ta=25°C</td> </tr> <tr> <td></td> <td></td> <td>--</td> <td>TBD</td> <td>--</td> <td>[Volt]</td> <td>I<sub>f</sub>=50mA, Ta=85°C</td> </tr> <tr> <td>P<sub>LED</sub></td> <td>LED Power Consumption</td> <td>--</td> <td>TBD</td> <td>--</td> <td>Watt</td> <td>I<sub>f</sub>=50mA, Ta=25°C</td> </tr> <tr> <td>Operation Lifetime</td> <td></td> <td>50,000</td> <td>--</td> <td>--</td> <td>Hrs</td> <td>I<sub>f</sub>=50mA, Ta=25°C</td> </tr> </tbody> </table>	Symbol	Parameter	Min.	Typ.	Max.	Unit	Remark	VCC	Input Voltage	10.8	12	12.6	[Volt]	--	I <sub>insh</sub>	Input Current	--	TBD	--	[A]	100% analog dimming	P <sub>VCC</sub>	Power Consumption	--	TBD	TBD	[Watt]	100% analog dimming	I <sub>insh LED</sub>	Inrush Current	--	--	TBD	[A]	at rising time=470us	Dimming	Swing Voltage	0.3	--	5.0	V	Analog Dimming	Display ON/OFF	On Control Voltage	2	3.3	5	[Volt]	--		Off Control Voltage	--	0	0.6	[Volt]	--		Brightness percentage	25	--	100	%	--	I <sub>f</sub>	LED Forward Current	--	TBD	TBD	mA	Ta=25°C			--	TBD	--	[Volt]	I <sub>f</sub> =50mA, Ta=-30°C	V <sub>f</sub>	LED Forward Voltage	--	TBD	TBD	[Volt]	I <sub>f</sub> =50mA, Ta=25°C			--	TBD	--	[Volt]	I <sub>f</sub> =50mA, Ta=85°C	P <sub>LED</sub>	LED Power Consumption	--	TBD	--	Watt	I <sub>f</sub> =50mA, Ta=25°C	Operation Lifetime		50,000	--	--	Hrs	I <sub>f</sub> =50mA, Ta=25°C	<b>5.2.1 Parameter guideline for LED</b> Following characteristics are measured under a stable condition using an inverter at 25°C (Room Temperature):- <table border="1"> <thead> <tr> <th>Symbol</th> <th>Parameter</th> <th>Min.</th> <th>Typ.</th> <th>Max.</th> <th>Unit</th> <th>Remark</th> </tr> </thead> <tbody> <tr> <td>VCC</td> <td>Input Voltage</td> <td>10.8</td> <td>12</td> <td>12.6</td> <td>[Volt]</td> <td>--</td> </tr> <tr> <td>I<sub>insh</sub></td> <td>Input Current</td> <td>--</td> <td>0.16</td> <td>--</td> <td>[A]</td> <td>100% analog dimming</td> </tr> <tr> <td>P<sub>VCC</sub></td> <td>Power Consumption</td> <td>--</td> <td>1.02</td> <td>2.65</td> <td>[Watt]</td> <td>100% analog dimming</td> </tr> <tr> <td>I<sub>insh LED</sub></td> <td>Inrush Current</td> <td>--</td> <td>--</td> <td>3.0</td> <td>[A]</td> <td>at rising time=470us</td> </tr> <tr> <td>Dimming</td> <td>Swing Voltage</td> <td>0.3</td> <td>--</td> <td>5.0</td> <td>V</td> <td>Analog Dimming</td> </tr> <tr> <td>Display ON/OFF</td> <td>On Control Voltage</td> <td>2</td> <td>3.3</td> <td>5</td> <td>[Volt]</td> <td>--</td> </tr> <tr> <td></td> <td>Off Control Voltage</td> <td>--</td> <td>0</td> <td>0.6</td> <td>[Volt]</td> <td>--</td> </tr> <tr> <td></td> <td>Brightness percentage</td> <td>25</td> <td>--</td> <td>100</td> <td>%</td> <td>--</td> </tr> <tr> <td>I<sub>f</sub></td> <td>LED Forward Current</td> <td>--</td> <td>50</td> <td>--</td> <td>mA</td> <td>Ta=25°C</td> </tr> <tr> <td></td> <td></td> <td>--</td> <td>30</td> <td>--</td> <td>[Volt]</td> <td>I<sub>f</sub>=50mA, Ta=-30°C</td> </tr> <tr> <td>V<sub>f</sub></td> <td>LED Forward Voltage</td> <td>--</td> <td>30</td> <td>33</td> <td>[Volt]</td> <td>I<sub>f</sub>=50mA, Ta=25°C</td> </tr> <tr> <td></td> <td></td> <td>--</td> <td>28.2</td> <td>--</td> <td>[Volt]</td> <td>I<sub>f</sub>=50mA, Ta=85°C</td> </tr> <tr> <td>P<sub>LED</sub></td> <td>LED Power Consumption</td> <td>--</td> <td>1.5</td> <td>--</td> <td>Watt</td> <td>I<sub>f</sub>=50mA, Ta=25°C</td> </tr> <tr> <td>Operation Lifetime</td> <td></td> <td>50,000</td> <td>--</td> <td>--</td> <td>Hrs</td> <td>I<sub>f</sub>=50mA, Ta=25°C</td> </tr> </tbody> </table>	Symbol	Parameter	Min.	Typ.	Max.	Unit	Remark	VCC	Input Voltage	10.8	12	12.6	[Volt]	--	I <sub>insh</sub>	Input Current	--	0.16	--	[A]	100% analog dimming	P <sub>VCC</sub>	Power Consumption	--	1.02	2.65	[Watt]	100% analog dimming	I <sub>insh LED</sub>	Inrush Current	--	--	3.0	[A]	at rising time=470us	Dimming	Swing Voltage	0.3	--	5.0	V	Analog Dimming	Display ON/OFF	On Control Voltage	2	3.3	5	[Volt]	--		Off Control Voltage	--	0	0.6	[Volt]	--		Brightness percentage	25	--	100	%	--	I <sub>f</sub>	LED Forward Current	--	50	--	mA	Ta=25°C			--	30	--	[Volt]	I <sub>f</sub> =50mA, Ta=-30°C	V <sub>f</sub>	LED Forward Voltage	--	30	33	[Volt]	I <sub>f</sub> =50mA, Ta=25°C			--	28.2	--	[Volt]	I <sub>f</sub> =50mA, Ta=85°C	P <sub>LED</sub>	LED Power Consumption	--	1.5	--	Watt	I <sub>f</sub> =50mA, Ta=25°C	Operation Lifetime		50,000	--	--	Hrs	I <sub>f</sub> =50mA, Ta=25°C	
Symbol	Parameter	Min.	Typ.	Max.	Unit	Remark																																																																																																																																																																																																																
VCC	Input Voltage	10.8	12	12.6	[Volt]	--																																																																																																																																																																																																																
I <sub>insh</sub>	Input Current	--	TBD	--	[A]	100% analog dimming																																																																																																																																																																																																																
P <sub>VCC</sub>	Power Consumption	--	TBD	TBD	[Watt]	100% analog dimming																																																																																																																																																																																																																
I <sub>insh LED</sub>	Inrush Current	--	--	TBD	[A]	at rising time=470us																																																																																																																																																																																																																
Dimming	Swing Voltage	0.3	--	5.0	V	Analog Dimming																																																																																																																																																																																																																
Display ON/OFF	On Control Voltage	2	3.3	5	[Volt]	--																																																																																																																																																																																																																
	Off Control Voltage	--	0	0.6	[Volt]	--																																																																																																																																																																																																																
	Brightness percentage	25	--	100	%	--																																																																																																																																																																																																																
I <sub>f</sub>	LED Forward Current	--	TBD	TBD	mA	Ta=25°C																																																																																																																																																																																																																
		--	TBD	--	[Volt]	I <sub>f</sub> =50mA, Ta=-30°C																																																																																																																																																																																																																
V <sub>f</sub>	LED Forward Voltage	--	TBD	TBD	[Volt]	I <sub>f</sub> =50mA, Ta=25°C																																																																																																																																																																																																																
		--	TBD	--	[Volt]	I <sub>f</sub> =50mA, Ta=85°C																																																																																																																																																																																																																
P <sub>LED</sub>	LED Power Consumption	--	TBD	--	Watt	I <sub>f</sub> =50mA, Ta=25°C																																																																																																																																																																																																																
Operation Lifetime		50,000	--	--	Hrs	I <sub>f</sub> =50mA, Ta=25°C																																																																																																																																																																																																																
Symbol	Parameter	Min.	Typ.	Max.	Unit	Remark																																																																																																																																																																																																																
VCC	Input Voltage	10.8	12	12.6	[Volt]	--																																																																																																																																																																																																																
I <sub>insh</sub>	Input Current	--	0.16	--	[A]	100% analog dimming																																																																																																																																																																																																																
P <sub>VCC</sub>	Power Consumption	--	1.02	2.65	[Watt]	100% analog dimming																																																																																																																																																																																																																
I <sub>insh LED</sub>	Inrush Current	--	--	3.0	[A]	at rising time=470us																																																																																																																																																																																																																
Dimming	Swing Voltage	0.3	--	5.0	V	Analog Dimming																																																																																																																																																																																																																
Display ON/OFF	On Control Voltage	2	3.3	5	[Volt]	--																																																																																																																																																																																																																
	Off Control Voltage	--	0	0.6	[Volt]	--																																																																																																																																																																																																																
	Brightness percentage	25	--	100	%	--																																																																																																																																																																																																																
I <sub>f</sub>	LED Forward Current	--	50	--	mA	Ta=25°C																																																																																																																																																																																																																
		--	30	--	[Volt]	I <sub>f</sub> =50mA, Ta=-30°C																																																																																																																																																																																																																
V <sub>f</sub>	LED Forward Voltage	--	30	33	[Volt]	I <sub>f</sub> =50mA, Ta=25°C																																																																																																																																																																																																																
		--	28.2	--	[Volt]	I <sub>f</sub> =50mA, Ta=85°C																																																																																																																																																																																																																
P <sub>LED</sub>	LED Power Consumption	--	1.5	--	Watt	I <sub>f</sub> =50mA, Ta=25°C																																																																																																																																																																																																																
Operation Lifetime		50,000	--	--	Hrs	I <sub>f</sub> =50mA, Ta=25°C																																																																																																																																																																																																																
0.4 2023/03/03	22	7.3 LED Light Bar Input Connector (CN4)	7.3 LED Light Bar Input Connector (CN3)																																																																																																																																																																																																																			
	23			Revise CN number																																																																																																																																																																																																																		

## AUO Display+

0.5 2023/05/11	24	<b>10.1 Shipping Label</b> (on the rear side of TFT-LCD display)- 	<b>10.1 Shipping Label</b> (on the rear side of TFT-LCD display)- 
1.0 2023/06/15		Final spec.	

AUO Display Plus Confidential  
 For DATAMODUL Internal Use Only  
 20230816 16:57:58

## 1. Operating Precautions

- 1) Since front polarizer is easily damaged, please be cautious not to scratch it.
- 2) Be sure to turn off power supply when inserting or disconnecting from input connector.
- 3) Wipe off water drop immediately. Long contact with water may cause discoloration or spots.
- 4) When the panel surface is soiled, wipe it with absorbent cotton or soft cloth.
- 5) Since the panel is made of glass, it may be broken or cracked if dropped or bumped on hard surface.
- 6) To avoid ESD (Electro Static Discharge) damage, be sure to ground yourself before handling TFT-LCD Module.
- 7) Do not open nor modify the module assembly.
- 8) Do not press the reflector sheet at the back of the module to any direction.
- 9) In case if a module has to be put back into the packing container slot after it was taken out from the container, do not press the center of the LED Reflector edge. Instead, press at the far ends of the LED Reflector edge softly. Otherwise the TFT Module may be damaged.
- 10) At the insertion or removal of the Signal Interface Connector, be sure not to rotate nor tilt the Interface Connector of the TFT Module.
- 11) After installation of the TFT Module into an enclosure (Notebook PC Bezel, for example), do not twist nor bend the TFT Module even momentary. At designing the enclosure, it should be taken into consideration that no bending/twisting forces are applied to the TFT Module from outside. Otherwise the TFT Module may be damaged.
- 12) Small amount of materials having no flammability grade is used in the LCD module. The LCD module should be supplied by power complied with requirements of Limited Power Source (IEC 62368-1), or be applied exemption.
- 13) Severe temperature condition may result in different luminance, response time.
- 14) Continuous operating TFT-LCD Module under high temperature environment may accelerate LED light bar exhaustion and reduce luminance dramatically.
- 15) The data on this specification sheet is applicable when LCD module is placed in landscape position.
- 16) Continuous displaying fixed pattern may induce image sticking. It is recommended to use screen saver or shuffle content periodically if fixed pattern is displayed on the screen.

## 2. General Description

This specification applies to the 7.0 inch color TFT LCD module G070VW01.0

G070VW01.0 designed with wide viewing angle; wide operating temperature and long life LEDs backlight is well suited to be the display units for Industrial Applications.

LED driving board for backlight unit is included in this panel.

G070VW01.0 is built in timing controller and LVDS interface.

The screen format is intended to support the WVGA (800(H) x 480(V)) screen and 16.2M (RGB 8-bits) or 262K colors (RGB 6-bits).

G070VW01.0 is a RoHS product.

## 2.1 Display Characteristics

The following items are characteristics summary on the table under 25°C condition:

Items	Unit	Specifications
Screen Diagonal	[inch]	7.0 (177.8mm)
Active Area	[mm]	152.40(H) x 91.44(V)
Pixels H x V		800 x 3(RGB) x 480
Pixel Pitch	[mm]	0.1905 x 0.1905
Pixel Arrangement		R.G.B. Vertical Stripe
Display Mode		AHVA, Normally Black
Nominal Input Voltage VDD	[Volt]	3.3 typ.
Typical Power Consumption	[Watt]	2.68 typ.
Weight	[Grams]	157 (max)
Physical Size	[mm]	170.0(W) x 111.0(H) x 7.5(D) (typ.)
Electrical Interface		1 channel LVDS
Surface Treatment		Anti-glare, Hardness 3H
Support Color		262K(6-bit) / 16.2M(8-bit)
Temperature Range Operating Storage (Non-Operating)	[°C] [°C]	-30 to +85 (panel surface temperature) -30 to +85
RoHS Compliance		RoHS Compliance

## 2.2 Optical Characteristics

The optical characteristics are measured under stable conditions at 25°C (Room Temperature):

Item	Unit	Conditions	Min.	Typ.	Max.	Note
White Luminance	[cd/m <sup>2</sup> ]	I <sub>F</sub> = 80mA (center point)	300	400	-	1
Uniformity		5 Points		-	1.3	1.2.3
Contrast Ratio			700	1000	-	4
	[msec]	Rising + Falling	-	25	35	5
Viewing Angle	[degree]	Horizontal (Right)	80	89	-	6
	[degree]	CR ≥ 10 (Left)	80	89	-	
	[degree]	Vertical (Upper)	80	89	-	
	[degree]	CR ≥ 10 (Lower)	80	89	-	
Color / Chromaticity Coordinates (CIE 1931)		Red x	0.573	0.623	0.673	1
		Red y	0.311	0.361	0.411	
		Green x	0.276	0.326	0.376	
		Green y	0.530	0.580	0.630	
		Blue x	0.097	0.147	0.197	
		Blue y	0.011	0.061	0.111	
		White x	0.26	0.31	0.36	
		White y	0.28	0.33	0.38	
Color Gamut	%		-	60	-	1

Note 1: Measurement method

Equipment : Pattern Generator, Power Supply, Digital Voltmeter, Luminance meter (SR\_3 or equivalent)

Aperture 1φwith 50cm viewing distance

Test Point Center

Environment < 1 lux

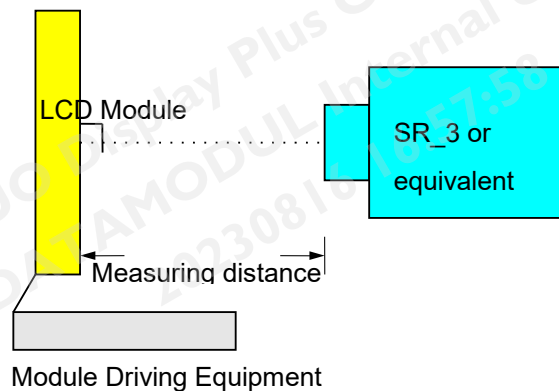



Note 2: Definition of 5 points position (Display active area: 152.40(H) x 91.44(V))

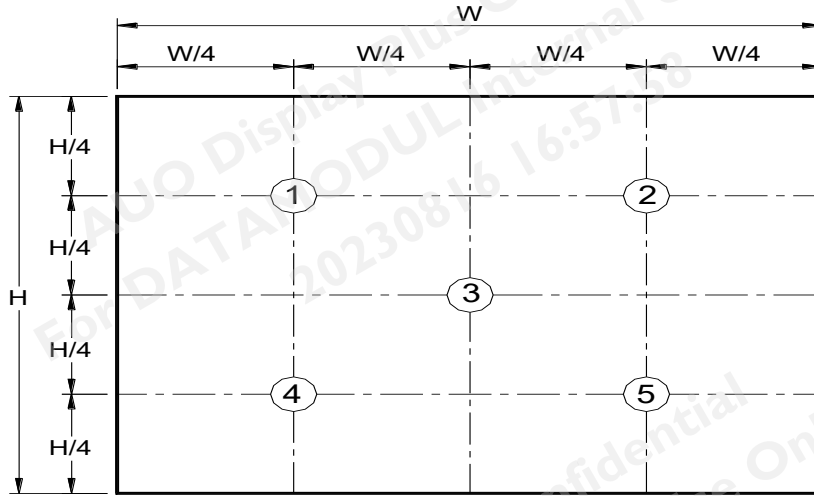

Note 3:

The luminance uniformity of 5 points is defined by dividing the maximum luminance value by the minimum luminance value at full white condition.

$$\delta_{w5} = \frac{\text{Maximum Brightness of five points}}{\text{Minimum Brightness of five points}}$$

Note 4 : Definition of contrast ratio (CR):

$$\text{Contrast ratio (CR)} = \frac{\text{Brightness on the "White" state}}{\text{Brightness on the "Black" state}}$$

Note 5: Definition of response time:

The output signals of photo detector are measured when the input signals are changed from "White" to "Black" (falling time) and from "Black" to "White" (rising time), respectively. The response time interval is between 10% and 90% of amplitudes. Please refer to the figure as below.

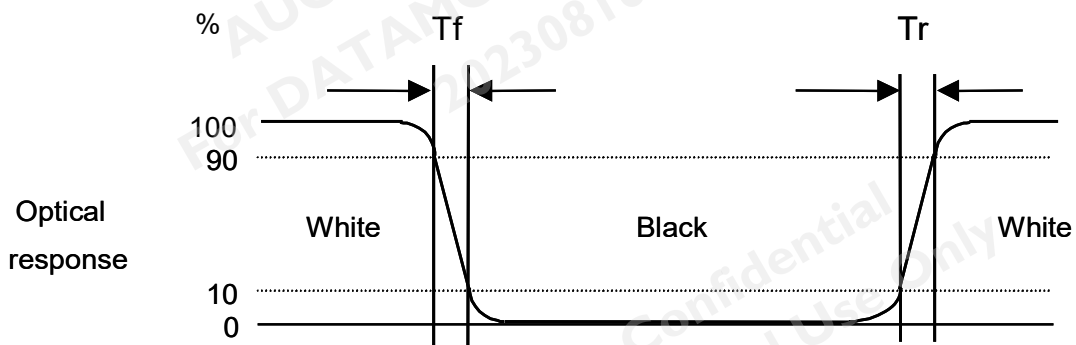

Note 6: Definition of viewing angle

Viewing angle is the measurement of contrast ratio  $\geq 10$ , at the screen center, over a 180° horizontal and 180° vertical range (off-normal viewing angles). The 180° viewing angle range is broken down as below: 90° ( $\theta$ ) horizontal left and right, and 90° ( $\phi$ ) vertical high (up) and low (down). The measurement direction is typically perpendicular to the display surface with the screen rotated to its center to develop the desired measurement viewing angle.

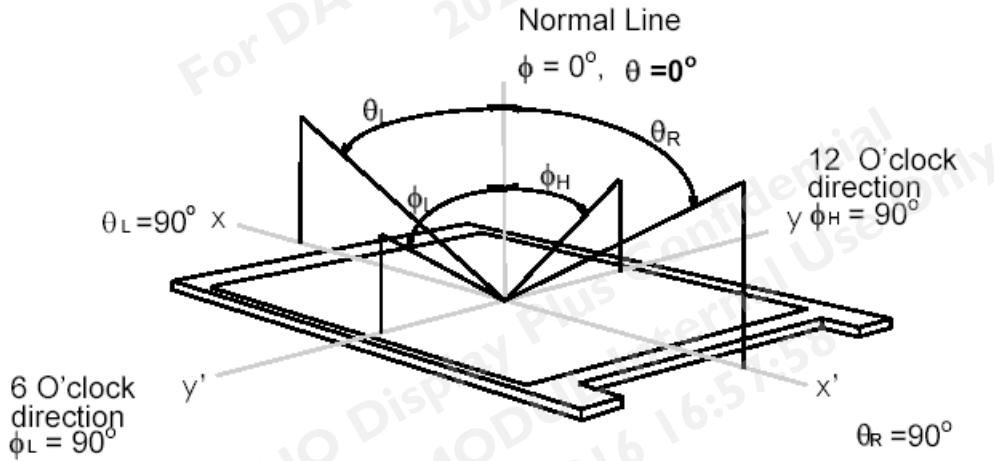

## 3. Functional Block Diagram

The following diagram shows the functional block of the 7.0 inch color TFT/LCD module:

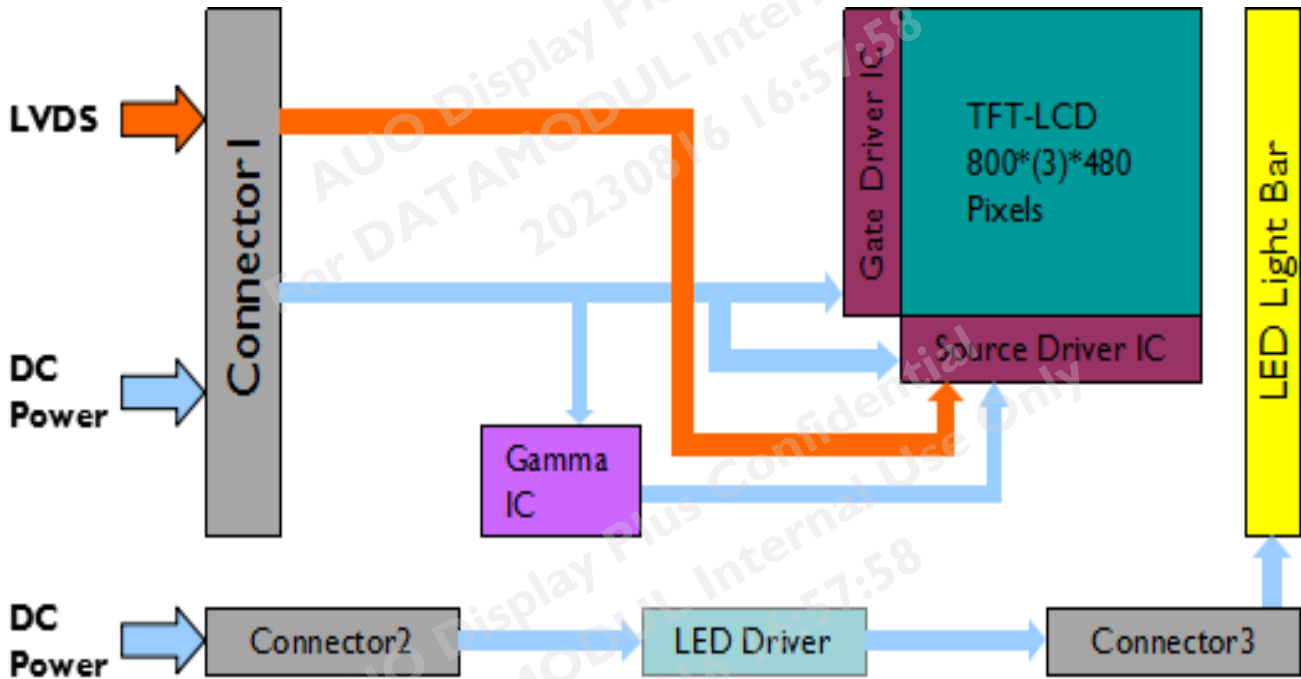

## 4. Absolute Maximum Ratings

### 4.1 Absolute Ratings of TFT LCD Module

Item	Symbol	Min	Max	Unit	Conditions
Logic/LCD Drive Voltage	VDD	-0.3	+3.6	[Volt]	

### 4.2 Absolute Ratings of Environment

Item	Symbol	Min	Max	Unit
Operating Temperature	TOP	-30	+85	[°C]
Operation Humidity	HOP	5	90	[%RH]
Storage Temperature	TST	-30	+85	[°C]
Storage Humidity	HST	5	90	[%RH]

Note: Maximum Wet-Bulb should be 39°C and no condensation.

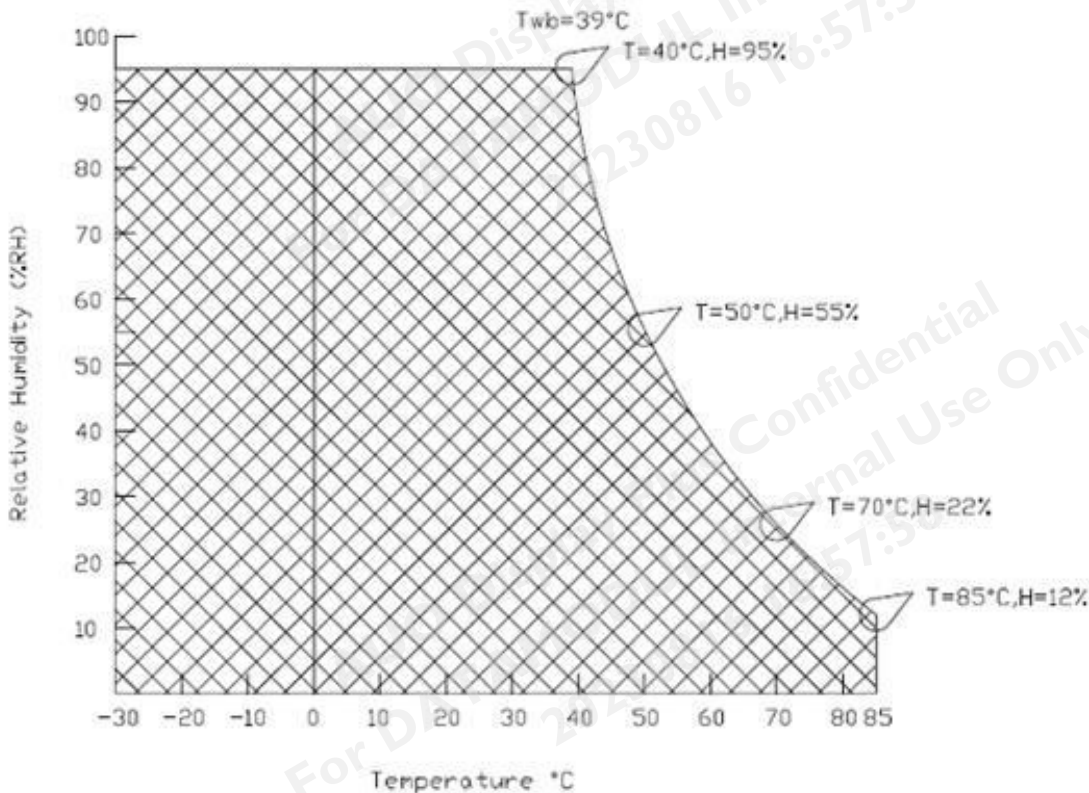

## 5. Electrical Characteristics

### 5.1 TFT LCD Module

#### 5.1.1 Power Specification

Symbol	Parameter	Min	Typ	Max	Units	Remark
VDD	Logic/LCD Drive Voltage	3.0	3.3	3.6	[Volt]	± 10%
I <sub>VDD</sub>	VDD Current	-	230	250	[mA]	64 Gray Bar Pattern (VDD=3.3V, at 60Hz)
I <sub>rush</sub>	LCD Inrush Current	-	-	3	[A]	Note 1
P <sub>VDD</sub>	VDD Power	-	0.76	0.9	[Watt]	64 Gray Bar Pattern (VDD=3.3V, at 60Hz)

Note 1: Measurement condition:

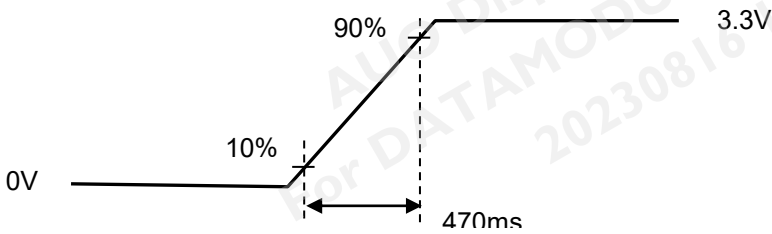
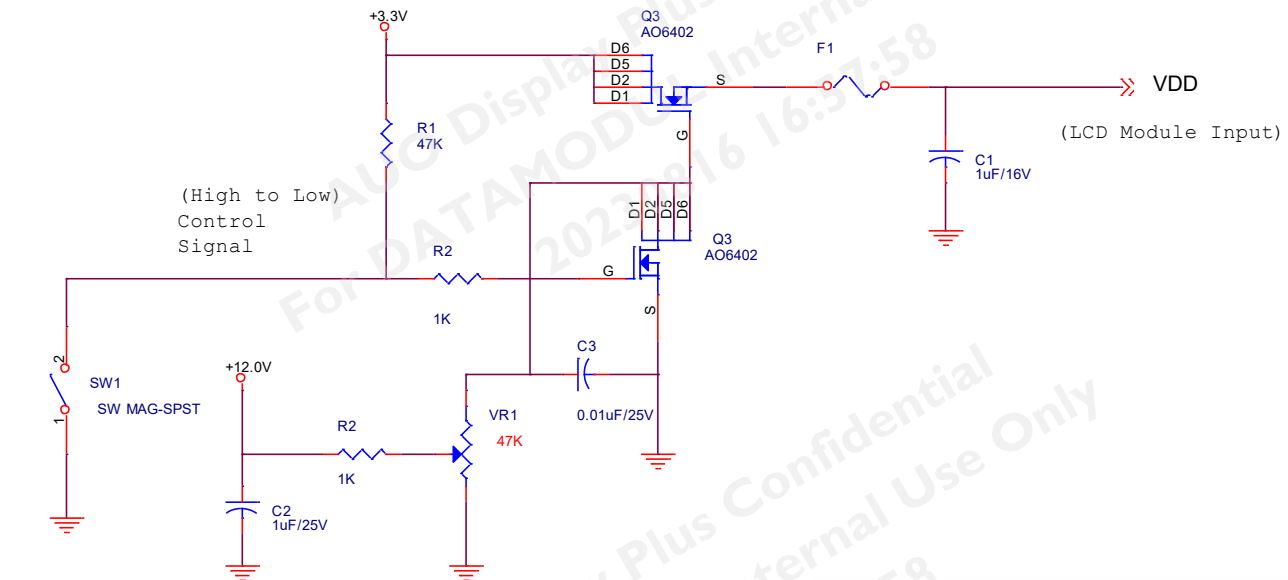

VDD rising time



64 Gray pattern

## 5.1.2 Signal Electrical Characteristics

Symbol	Item	Min.	Typ.	Max.	Unit	Remark
VTH	Differential Input High Threshold	-	-	100	[mV]	VICM=1.2V
VTL	Differential Input Low Threshold	-100	-	-	[mV]	VICM=1.2V
VID	Input Differential Voltage	100	400	600	[mV]	
VICM	Differential Input Common Mode Voltage	1.1		1.6	[V]	VTH/VTL=±100mV

Input signals shall be low or Hi-Z state when VDD is off.

Note: LVDS Signal Waveform.

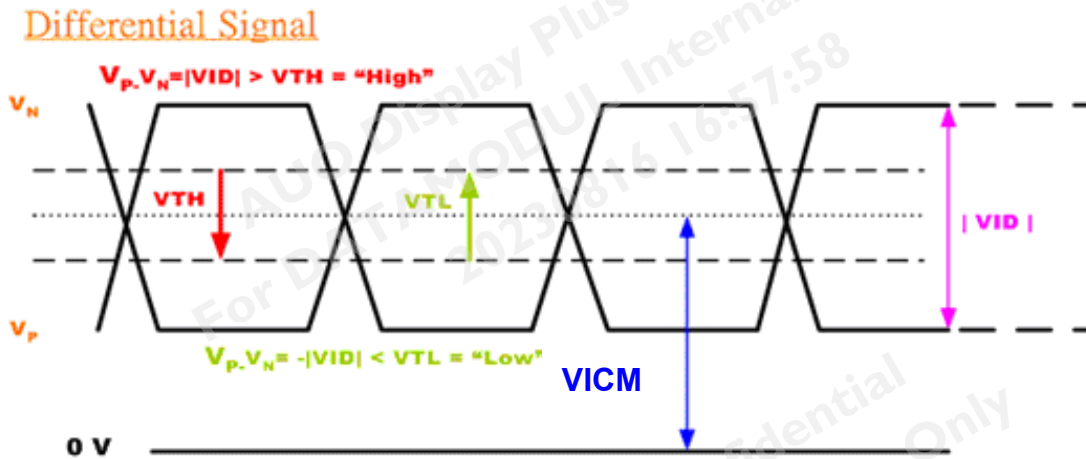

## 5.2 Backlight Unit

### 5.2.1 Parameter guideline for LED

Following characteristics are measured under a stable condition using an inverter at 25°C (Room Temperature):

Symbol	Parameter	Min.	Typ.	Max.	Unit	Remark
<b>VCC</b>	Input Voltage	10.8	12	12.6	[Volt]	
<b>I<sub>VCC</sub></b>	Input Current	-	0.16	-	[A]	100% analog dimming
<b>P<sub>VCC</sub></b>	Power Consumption	-	1.92	2.65	[Watt]	100% analog dimming
<b>I<sub>rush LED</sub></b>	Inrush Current	-	-	3.0	[A]	at rising time=470us
<b>Dimming</b>	Swing Voltage	0.3		5.0	V	Analog Dimming
<b>Display ON/OFF</b>	On Control Voltage	2	3.3	5	[Volt]	
	Off Control Voltage	-	0	0.6	[Volt]	
	Brightness percentage	25		100	%	
<b>I<sub>F</sub></b>	LED Forward Current	-	50	-	mA	Ta=25°C
<b>V<sub>F</sub></b>	LED Forward Voltage	-	30	-	[Volt]	I <sub>F</sub> =50mA, Ta=-30°C
		-	30	33	[Volt]	I <sub>F</sub> =50mA, Ta=25°C
		-	29.2	-		I <sub>F</sub> =50mA, Ta=85°C
<b>P<sub>LED</sub></b>	LED Power Consumption	-	1.5	-	Watt	I <sub>F</sub> =50mA, Ta=25°C
<b>Operation Lifetime</b>		50,000			Hrs	I <sub>F</sub> =50mA, Ta=25°C

Note 1: Ta means ambient temperature of TFT-LCD module.

Note 2: VCC, I<sub>VCC</sub>, P<sub>VCC</sub>, I<sub>rush LED</sub> are defined for LED B/L. (100% analog dimming).

Note 3: I<sub>F</sub>, V<sub>F</sub>, P<sub>LED</sub> are defined for LED Light Bar. There is one LED channel (AN1-CA1) in back light unit.

Note 4: If G070VW01.0 module is driven by high current or at high ambient temperature & humidity condition. The operating life will be reduced.

Note 5: Operating life means brightness goes down to 50% initial brightness. Typical operating life time is estimated data.

AUO Display+

## 6. Signal Characteristic

### 6.1 Pixel Format Image

Following figure shows the relationship between input signal and LCD pixel format.

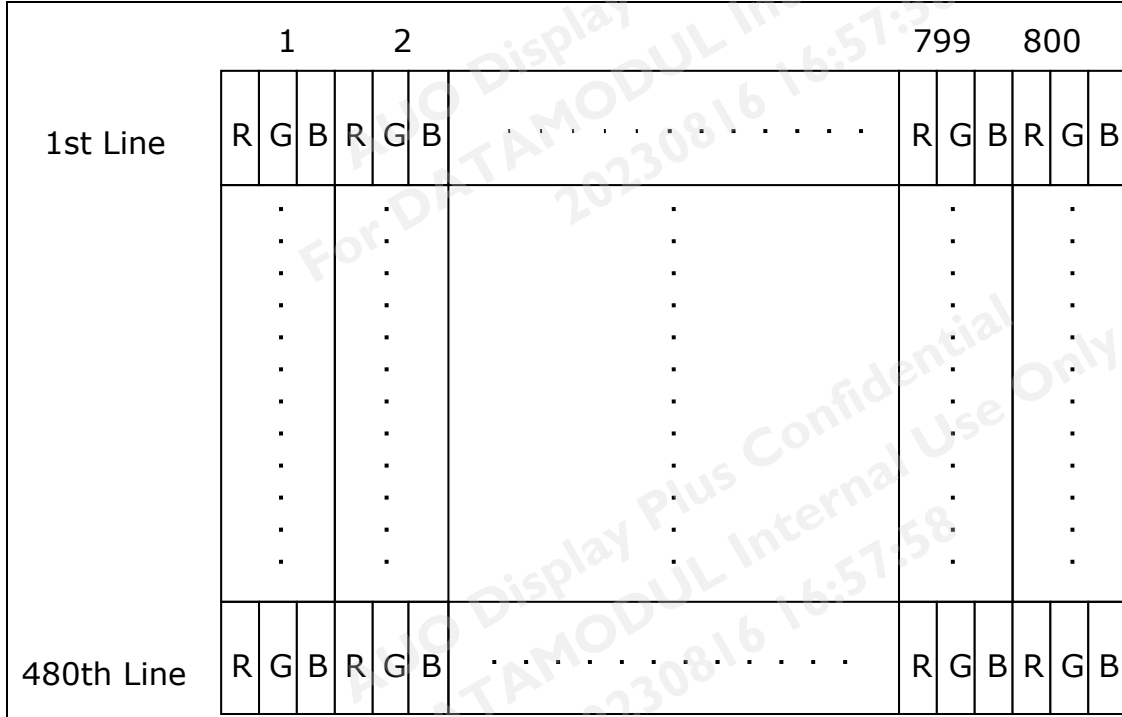



## AUO Display+

### 6.2 Signal Description

LVDS is a differential signal technology for LCD interface and high speed data transfer device. The connector pin definition is as below.

Pin No.	Symbol	Description
1	VDD	Power Supply, 3.3V (typical)
2	VDD	Power Supply, 3.3V (typical)
3	UD	Vertical Reverse Scan Control, When UD=High or NC → Normal Mode. When UD=Low → Vertical Reverse Scan. <small>Note 1</small>
4	LR	Horizontal Reverse Scan Control, When LR=High or NC → Normal Mode. When LR=Low → Horizontal Reverse Scan. <small>Note 1</small>
5	RxIN1-	LVDS differential data input Pair 0
6	RxIN1+	
7	GND	Ground
8	RxIN2-	LVDS differential data input Pair 1
9	RxIN2+	
10	GND	Ground
11	RxIN3-	LVDS differential data input Pair 2
12	RxIN3+	
13	GND	Ground
14	RxCLKIN-	LVDS differential Clock input Pair
15	RxCLKIN+	
16	GND	Ground
17	SEL 68	LVDS 6/8 bit select function control, Low or NC → 6 Bit Input Mode. High → 8 Bit Input Mode. <small>Note</small>
18	NC	NC
19	RxIN4-	LVDS differential data input Pair 3. Pin19: VDD & PIN20: GND for 6 Bit Input Mode <small>Note2</small>
20	RxIN4+	

Note 1: "Low" stands for 0V. "High" stands for 3.3V. "NC" stands for "No Connected."

Note 2:

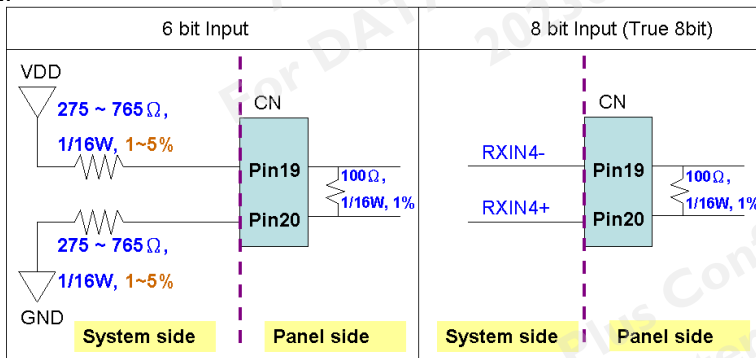

AUO Display+

## 6.3 Scanning Direction

The following figures show the image seen from the front view. The arrow indicates the direction of scan.



Fig. 1



Fig. 2



Fig. 3

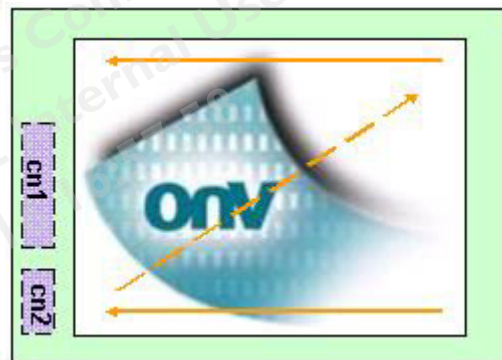

Fig. 4

Fig. 1 Normal scan (Pin3, UD = High or NC; Pin4, RL = High or NC)

Fig. 2 Reverse scan (Pin3, UD = High or NC; Pin4, RL = Low)

Fig. 3 Reverse scan (Pin3, UD = Low; Pin4, RL = High or NC)

Fig. 4 Reverse scan (Pin3, UD = Low; Pin4, RL = Low)

## 6.4 The Input Data Format

### 6.4.1 SEL68

**SEL68 = "Low" or "NC" for 6 bits LVDS Input**

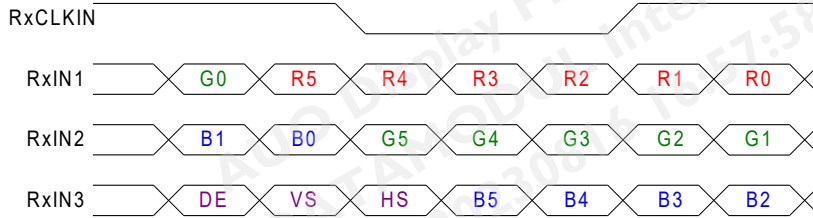

**SEL68 = "High" for 8 bits LVDS Input**

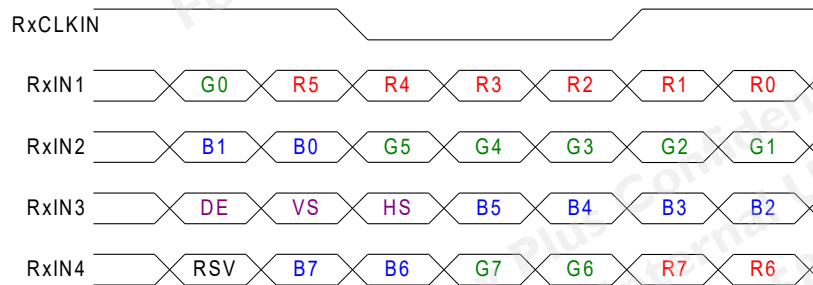

**Note1:** Please follow PSWG.

**Note2:** R/G/B data 7:MSB, R/G/B data 0:LSB

Signal Name	Description	Remark
R7 R6 R5 R4 R3 R2 R1 R0	Red Data 7 (MSB) Red Data 6 Red Data 5 Red Data 4 Red Data 3 Red Data 2 Red Data 1 Red Data 0 (LSB)	Red-pixel Data Each red pixel's brightness data consists of these 8 bits pixel data.
G7 G6 G5 G4 G3 G2 G1 G0	Green Data 7 (MSB) GreenData 6 GreenData 5 GreenData 4 GreenData 3 GreenData 2 GreenData 1 GreenData 0 (LSB)	Green-pixel Data Each green pixel's brightness data consists of these 8 bits pixel data.
B7 B6 B5 B4 B3 B2 B1 B0	Blue Data 7 (MSB) Blue Data 6 Blue Data 5 Blue Data 4 Blue Data 3 Blue Data 2 Blue Data 1 Blue Data 0 (LSB)	Blue-pixel Data Each blue pixel's brightness data consists of these 8 bits pixel data.
RxCLKIN+ RxCLKIN-	LVDS Clock Input	
DE	Display Enable	
VS	Vertical Sync	
HS	Horizontal Sync	

Note: Output signals from any system shall be low or Hi-Z state when VDD is off.

AUO Display+

## 6.5 Interface Timing

### 6.5.1 Timing Characteristics

**DE mode only**

Parameter	Symbol	Min.	Typ.	Max.	Unit	Condition
Clock frequency	$1/T_{\text{Clock}}$	27	33.3	39.4	MHz	
Vertical Section	Period	$T_V$	490	508	530	$T_H$
	Active	$T_{VD}$	480	480	480	
	Blanking	$T_{VB}$	10	28	50	
Horizontal Section	Period	$T_H$	920	1056	1240	$T_{\text{Clock}}$
	Active	$T_{HD}$	800	800	800	
	Blanking	$T_{HB}$	120	256	440	

Note: Frame rate is 60 Hz.

Note: DE mode.

### 6.5.2 Input Timing Diagram

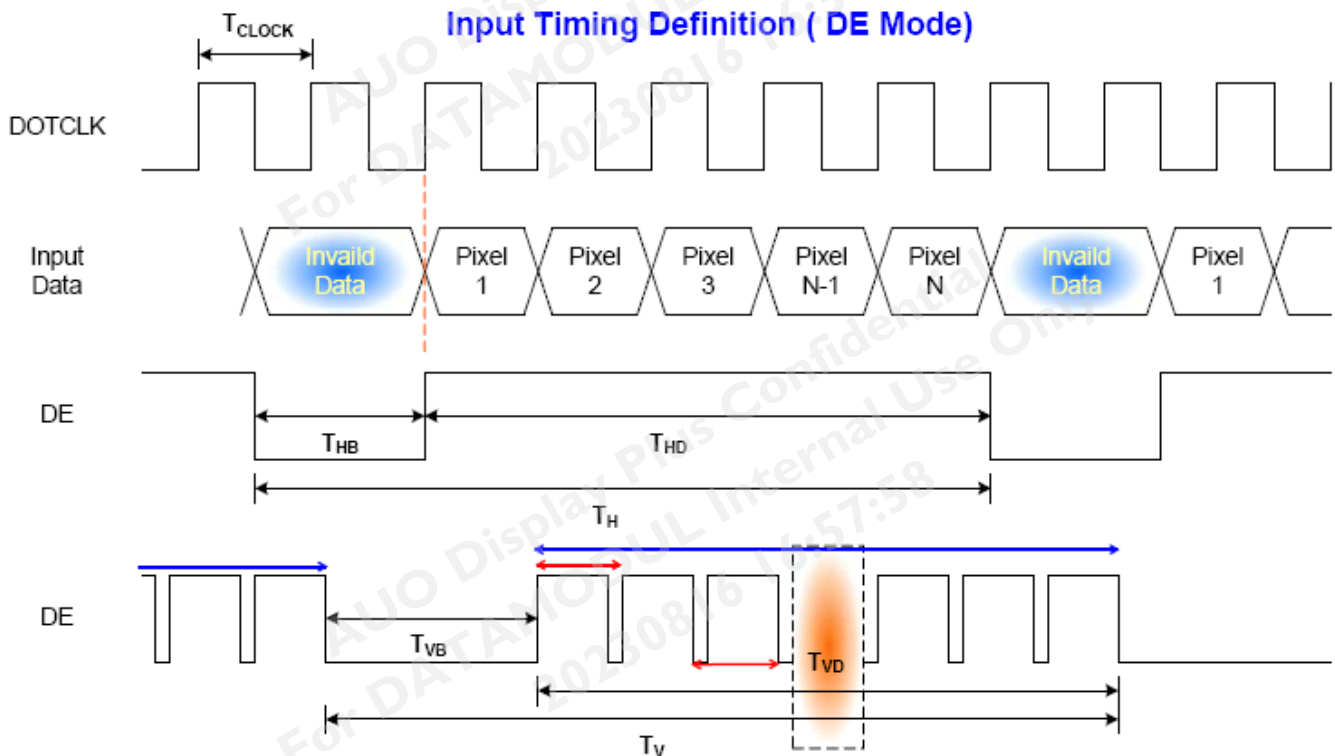

## 6.6 Power ON/OFF Sequence

VDD power and backlight on/off sequence is as below. Interface signals are also shown in the chart. Signals from any system shall be Hi-Z state or low level when VDD is off.

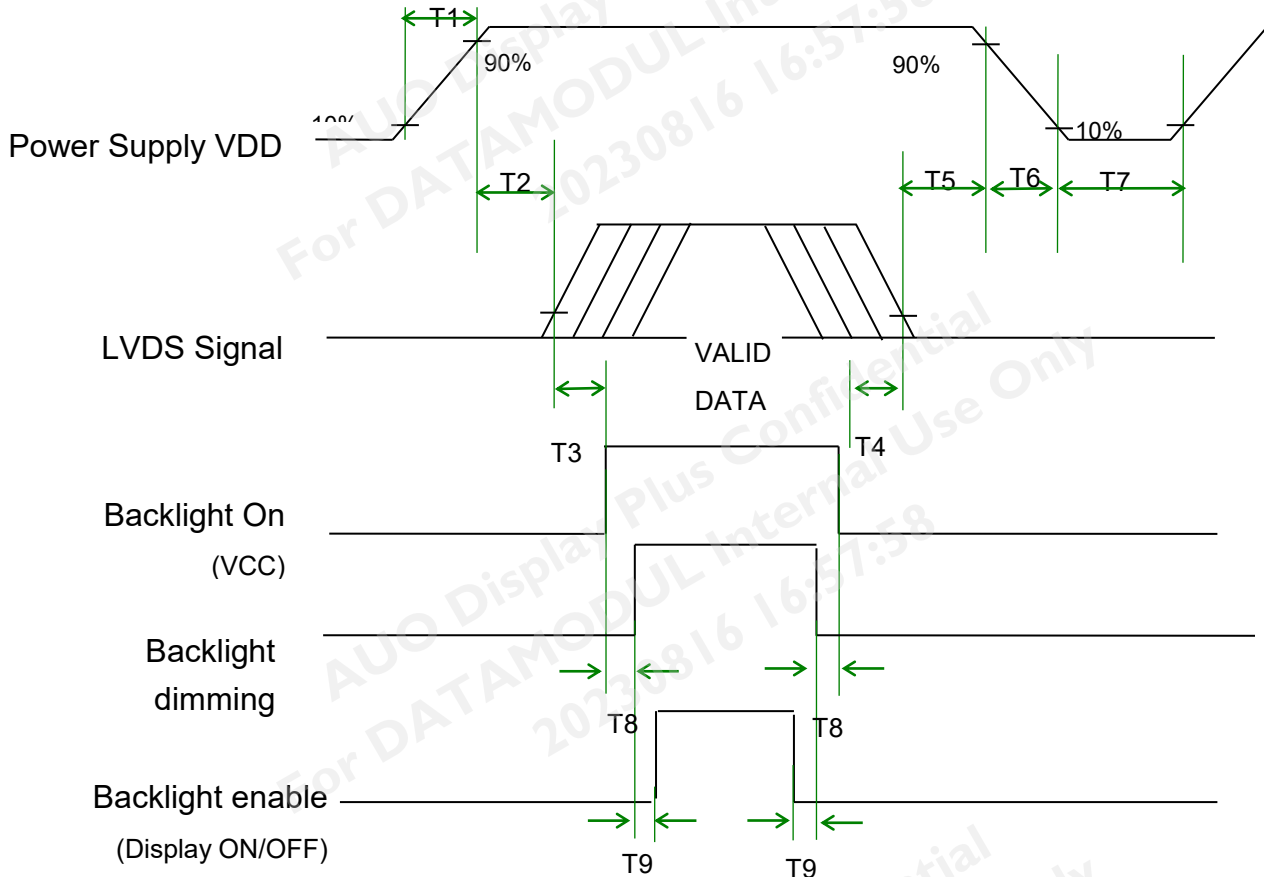

**Power ON/OFF sequence timing**

Parameter	Value			Units
	Min.	Typ.	Max.	
T1	0.5	-	10	ms
T2	0	40	50	ms
T3	300	-	-	ms
T4	200	-	-	ms
T5	0	16	50	ms
T6	0	-	10	ms
T7	1000	-	-	ms
T8	10	-	-	ms
T9	10	-	-	ms

The above on/off sequence should be applied to avoid abnormal function in the display. Please make sure to turn off the power when you plug the cable into the input connector or pull the cable out of the connector.

AUO Display+

## 7. Connector & Pin Assignment

Physical interface is described as for the connector on module. These connectors are capable of accommodating the following signals and will be following components.

### 7.1 TFT LCD Signal (CN1): LVDS Connector

Connector Name / Designation	Signal Connector
Manufacturer	STM or compatible
Connector Model Number	STM MSB24013P20HA or compatible
Mating Model Number	Hirose-DF19-20S-1C or compatible

Pin No.	Signal Name	Pin No.	Signal Name
1	VDD	2	VDD
3	UD	4	LR
5	RxIN1-	6	RxIN1+
7	GND	8	RxIN2-
9	RxIN2+	10	GND
11	RxIN3-	12	RxIN3+
13	GND	14	RxCKIN-
15	RxCKIN+	16	GND
17	SEL 68	18	NC
19	RxIN4-	20	RxIN4+

### 7.2 LED Backlight Unit (CN2): LED Driver Connector

Connector Name / Designation	LED Driver Connector
Manufacturer	STM
Connector Model Number	MSB24038P4D or compatible
Mating Model Number	P24038P4 or compatible

Pin #	Symbol	Pin Description
1	GND	GND
2	Display ON/OFF	+3.3V: ON, 0V: OFF
3	Dimming	Analog Dimming
4	VCC12V	12V Power Input

## 7.3 LED Light Bar Input Connector (CN3):

<b>Manufacturer</b>	STM or compatible
<b>Connector Model Number</b>	MSB24038P2D or compatible
<b>Mating Connector Model Number</b>	P24038P2 or compatible

Pin #	Symbol	Pin Description
1	AN1	LED anode
2	CA1	LED cathode

Pin #	Symbol	Cable color
1	AN1	Red
2	CA1	Black

## 8. Reliability Test Criteria

Items	Required Condition	Note
Temperature Humidity Bias	40°C/90%, 300 hours	
High Temperature Operation	85°C, 300 hours	
Low Temperature Operation	-30°C, 300 hours	
Hot Storage	85°C, 300 hours	
Cold Storage	-30°C, 300 hours	
Thermal Shock Test	-20°C/30 min, 60°C/30 min, 100 cycles	
Shock Test (Non-Operating)	50G, 20ms, Half-sine wave ( $\pm X$ , $\pm Y$ , $\pm Z$ )	
Vibration Test (Non-Operating)	1.5G, (10~200Hz, P-P) 30 mins/axis (X, Y, Z)	
On/off test	On/10 sec, Off/10 sec, 30,000 cycles	
ESD	Contact Discharge: $\pm 8KV$ , 150pF (330 $\Omega$ ) 1sec, 8 points, 25 times/point Air Discharge: $\pm 15KV$ , 150pF (330 $\Omega$ ) 1sec, 8 points, 25 times/point	Note 1

Note1: According to EN61000-4-2, ESD class B: Some performance degradation allowed. No data lost  
Self-recoverable. No hardware failures.

Note2:

- The reliability test is performed only to examine the TFT-LCD module capability
- No function failure occurs. Mura shall be ignored after high temperature reliability test.

AUO Display+

## 9. Mechanical Characteristics

### 9.1 LCM Front View

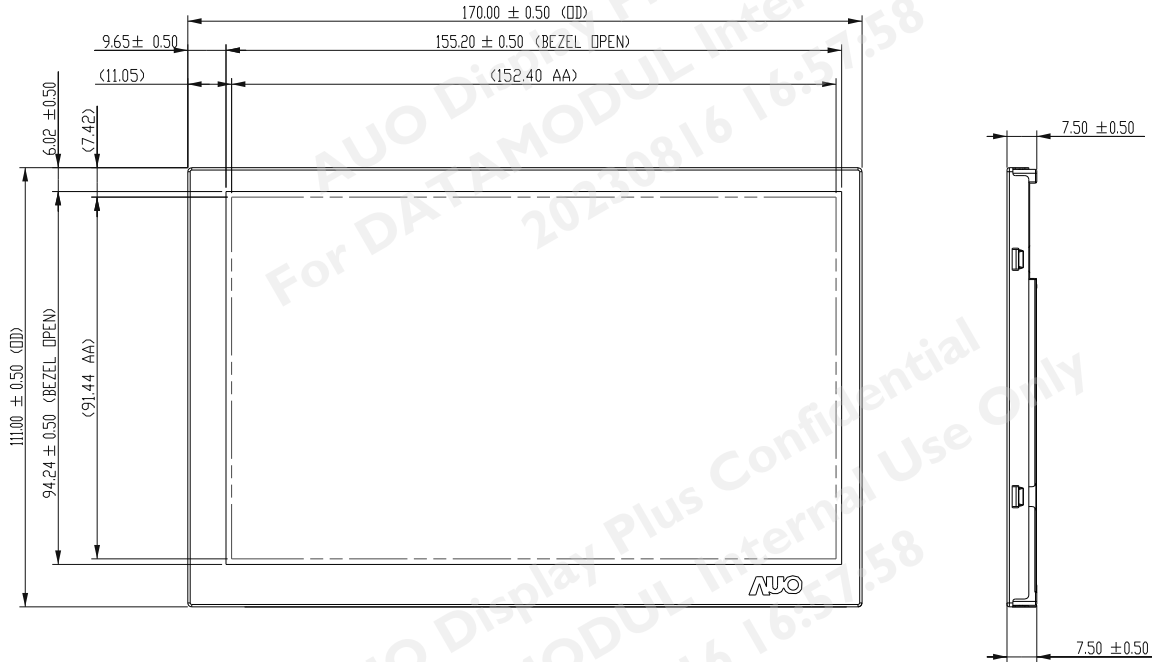

### 9.2 LCM Rear View

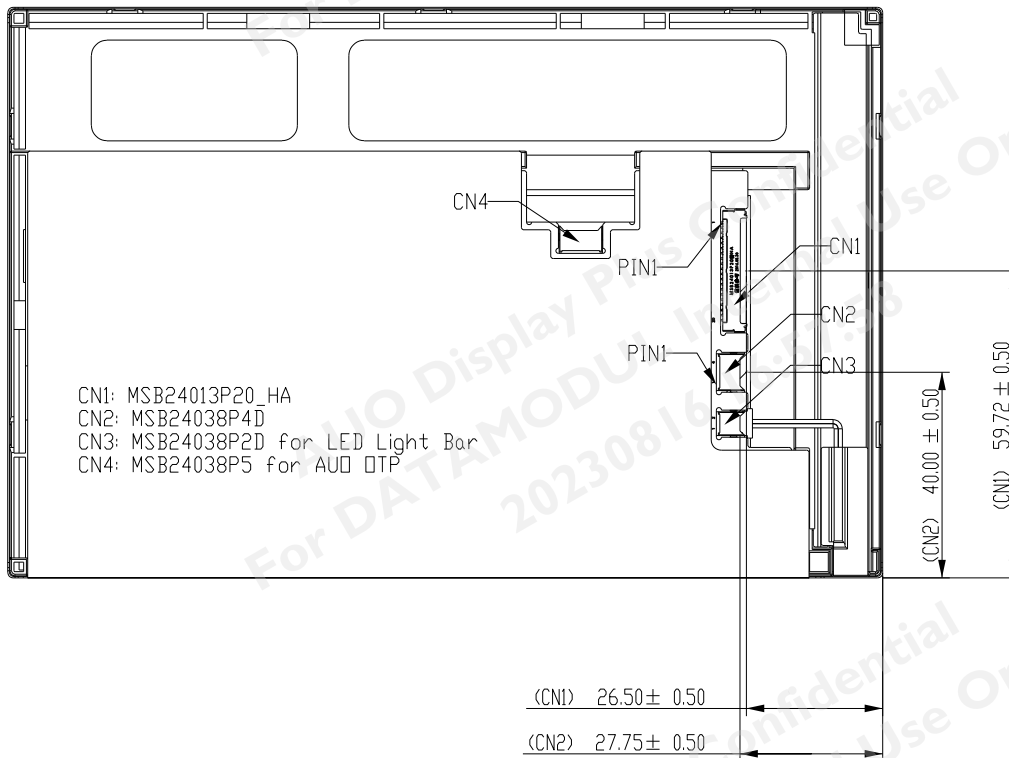



AUO Display+

## 10. Label and Packaging

### 10.1 Shipping Label (on the rear side of TFT-LCD display)

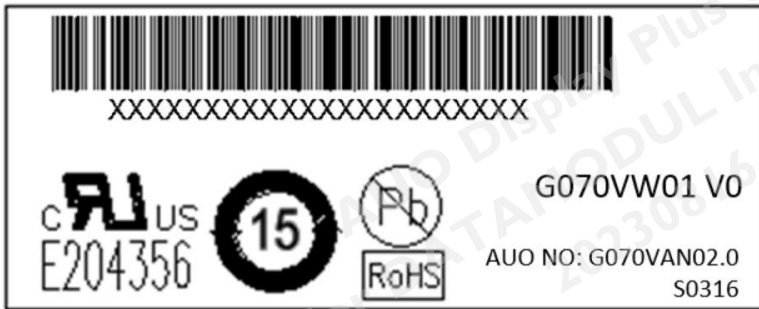

### 10.2 Carton Package

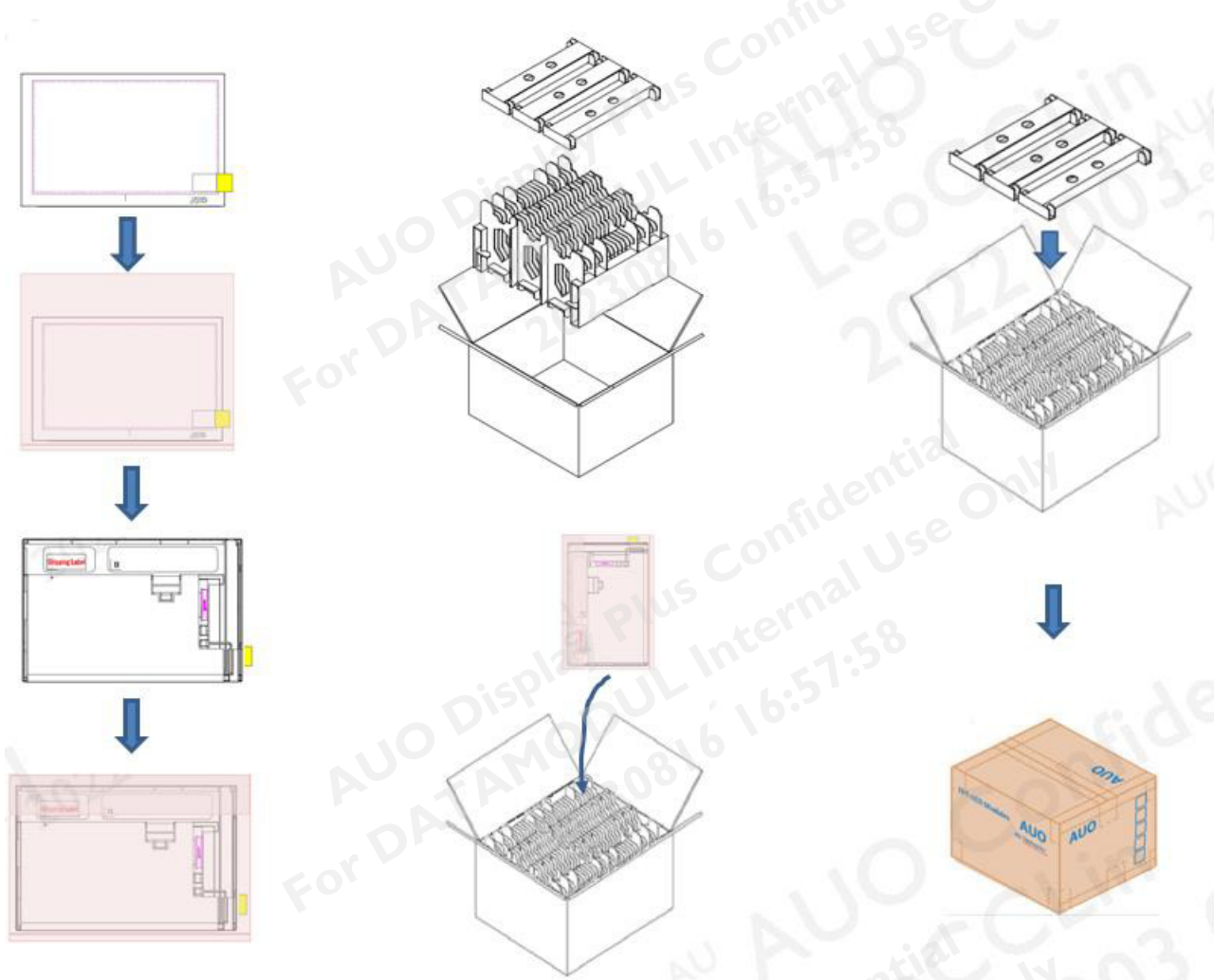

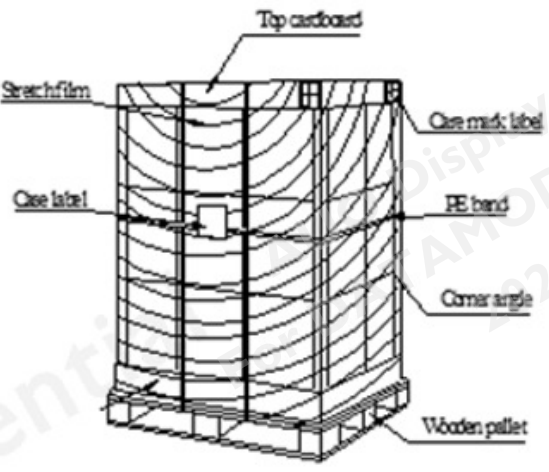

Total 60 pcs Module/Carton  
 Max weight : 14.5 kg  
 Carton : 434(L)\*377(W)\*264(H)mm  
 Pallet size 1140 X 890 X 140 mm  
 Pallet Model name : M24  
 Box stacked : (3 \* 2) \* 5 layers,  
 One pallet put 30 Boxes,  
 Total 1800 pcs Module

AUO Display Plus Confidential  
 For DATAMODUL Internal Use Only  
 20230816 16:57:58

AUO Display+

## 11 Safety

### 11.1 Keen Edge Requirements

There will be no keen edges or corners on the display assembly that could cause injury.

### 11.2 Materials

#### 11.2.1 Toxicity

There will be no carcinogenic materials used anywhere in the TFT-LCD module. If toxic materials are used, they will be reviewed and approved by the responsible AUO toxicologist.

#### 11.2.2 Flammability

The printed circuit board will be made from material rated 94 V-1 or better. The actual UL flammability rating will be printed on the printed circuit board.

### 11.3 Capacitors

If any polarized capacitors are used in the TFT-LCD module, provisions will be made to keep them from being inserted backwards.

### 11.4 International Safety Standard Compliance

The TFT-LCD Module will satisfy all requirements for compliance to IEC/UL 62368-1.



ALL TECHNOLOGIES. ALL COMPETENCIES. ONE SPECIALIST.

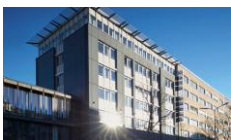

DATA MODUL AG  
Landsberger Straße 322  
DE-80687 Munich  
Phone: +49-89-56017-0

DATA MODUL WEIKERSHEIM GMBH  
Lindenstraße 8  
DE-97990 Weikersheim  
Phone: +49-7934-101-0

