

Specification

G104XCE-LH1

10,4" - 1024 x 768 – XGA-LVDS

Spec Revision: 2.1
Revision Date: 13.09.2023

Note: This specification is subject to change without prior notice

Doc. Number :

- Tentative Target Specification
- Preliminary Specification
- Approval Specification

MODEL NO.: G104XCE
SUFFIX: LH1

Customer: Common	
APPROVED BY	SIGNATURE
Name / Title _____	_____
Note	
Product Version	

Please return 1 copy for your confirmation with your signature and comments.	

Approved By	Checked By	Prepared By
林秋森	吳承旻	阮志昌

CONTENTS

1. GENERAL DESCRIPTION	5
1.1 OVERVIEW	5
1.2 FEATURES.....	5
1.3 APPLICATION	5
1.4 GENERAL SPECIFICATIONS	5
1.5 MECHANICAL SPECIFICATIONS.....	5
2. ABSOLUTE MAXIMUM RATINGS	6
2.1 ABSOLUTE RATINGS OF ENVIRONMENT.....	6
2.2 ELECTRICAL ABSOLUTE RATINGS	7
2.2.1 TFT LCD MODULE	7
2.2.2 LED CONVERTER.....	7
3. ELECTRICAL CHARACTERISTICS	8
3.1 TFT LCD MODULE	8
3.2 BACKLIGHT UNIT	10
4. BLOCK DIAGRAM	11
4.1 TFT LCD MODULE	11
5. INTERFACE PIN ASSIGNMENT	12
5.1 TFT LCD MODULE	12
5.2 BACKLIGHT UNIT (CONVERTER CONNECTOR PIN).....	13
5.3 COLOR DATA INPUT ASSIGNMENT	15
6. INTERFACE TIMING	17
6.1 INPUT SIGNAL TIMING SPECIFICATIONS	17
6.2 POWER ON/OFF SEQUENCE.....	20
6.3 THE INPUT DATA FORMAT	21
6.4 SCANNING DIRECTION	23
7. OPTICAL CHARACTERISTICS	24
7.1 TEST CONDITIONS	24
7.2 OPTICAL SPECIFICATIONS.....	24
8. RELIABILITY TEST CRITERIA	27
9. PACKAGING.....	28
9.1 PACKING SPECIFICATIONS	28
9.2 PACKING METHOD	28
9.3 UN-PACKING METHOD.....	29
10. DEFINITION OF LABELS.....	30
10.1 INNOLUX MODULE LABEL	30
11. PRECAUTIONS	31

11.1 ASSEMBLY AND HANDLING PRECAUTIONS.....	31
11.2 STORAGE PRECAUTIONS.....	31
11.3 OTHER PRECAUTIONS.....	32
12. MECHANICAL CHARACTERISTIC	33

REVISION HISTORY

Version	Date	Page	Description
Ver.2.0	10 Jan 2022	All	Spec Ver.2.0 was first issued.
Ver.2.1	13 Sep 2023	All	Drive IC type from EK77221ABI096A change to EK77526AHI205A. SPEC Version from 2.0 to 2.1.
		5	1.1 Overview:Display Colors is 16.7M colors & deleted 6-bits colors with FRC.
			1.4 Total power consumption from 7.47W(Typ) to 7.7W(Typ).
			1.4 @cell 1.67W(Typ) to @cell 1.9W (Typ).
		8	Modify 3.1 TFT LCD MODULE : Power Supply Voltage Value Power Supply Current White & Black Value Power Consumption Value.
		12	Modify 5.1 TFT LCD MODULE: Note (3).

The copyright belongs to InnoLux. Any unauthorized use is prohibited.

1. GENERAL DESCRIPTION

1.1 OVERVIEW

G104XCE- LH1 is a 10.4" IAV TFT Liquid Crystal Display module with LED backlight unit and 30-pin-and-1ch LVDS interface. This product supports 1024 x 768 XGA format and can display true 16.7M colors. The PSWG is to establish a set of displays with standard mechanical dimensions and select electrical interface requirements for an industry standard 10.4" XGA LCD panel and the LED driving device for Backlight is built in PCBA.

1.2 FEATURES

- Excellent brightness (1000 nits)
- Ultra high contrast ratio (1000:1)
- Fast response time ($T_R + T_F = 25$ ms)
- XGA (1024 x 768 pixels) resolution
- DE (Data Enable) only mode
- LVDS (Low Voltage Differential Signaling) interface
- PSWG (Panel Standardization Working Group)
- Ultra wide viewing angle: 168(H)/ 168(V) (CR>10) AAS technology
- 180 degree rotation display option
- Wide operation temperature

1.3 APPLICATION

- TFT LCD monitor
- Industrial applications

1.4 GENERAL SPECIFICATIONS

Item	Specification	Unit	Note
Active Area	210.4 (H) x 157.8 (V) (10.4" diagonal)	mm	(1)
Bezel Opening Area	215.4 (H) x 161.8 (V)	mm	
Driver Element	a-si TFT active matrix	-	-
Pixel Number	1024 x R.G.B. x 768	pixel	-
Pixel Pitch (Sub Pixel)	0.0685 (H) x 0.2055 (V)	mm	-
Pixel Arrangement	RGB vertical stripe	-	-
Display Colors	262K/16.7M	color	-
Display Operation Mode	Transmissive mode / Normally black	-	-
Surface Treatment	Anti Glare	-	-
Total power consumption	Total 10.1W(Typ) @cell 1.9W (Typ),BL 8.2W (Typ)	W	typ

Note (1) Please refer to the attached drawings for more information of front and back outline dimensions.

1.5 MECHANICAL SPECIFICATIONS

Item	Min.	Typ.	Max.	Unit	Note	
Module Size	Horizontal (H)	225	225.5	226	mm	(1)
	Vertical (V)	175.8	176.3	176.8	mm	
	Depth (D)	8.2	8.7	9.2	mm	-
Weight		320	335	g	-	

Note (1) Please refer to the attached drawings for more information of front and back outline dimensions.

2. ABSOLUTE MAXIMUM RATINGS

2.1 ABSOLUTE RATINGS OF ENVIRONMENT

Item	Symbol	Value		Unit	Note
		Min.	Max.		
Operating Ambient Temperature	T _{OP}	-30	+85	°C	(1)(2)
Storage Temperature	T _{ST}	-30	+85	°C	

Note (1)

- (a) 90 %RH Max.
- (b) Wet-bulb temperature should be 39 °C Max.
- (c) No condensation.

Note (2) Panel surface temperature should be 0°C min. and 85°C max under Vcc=3.3V, fr =60Hz, typical LED string current, 25°C ambient temperature, and no humidity control . Any condition of ambient operating temperature ,the surface of active area should be keeping not higher than 85°C .

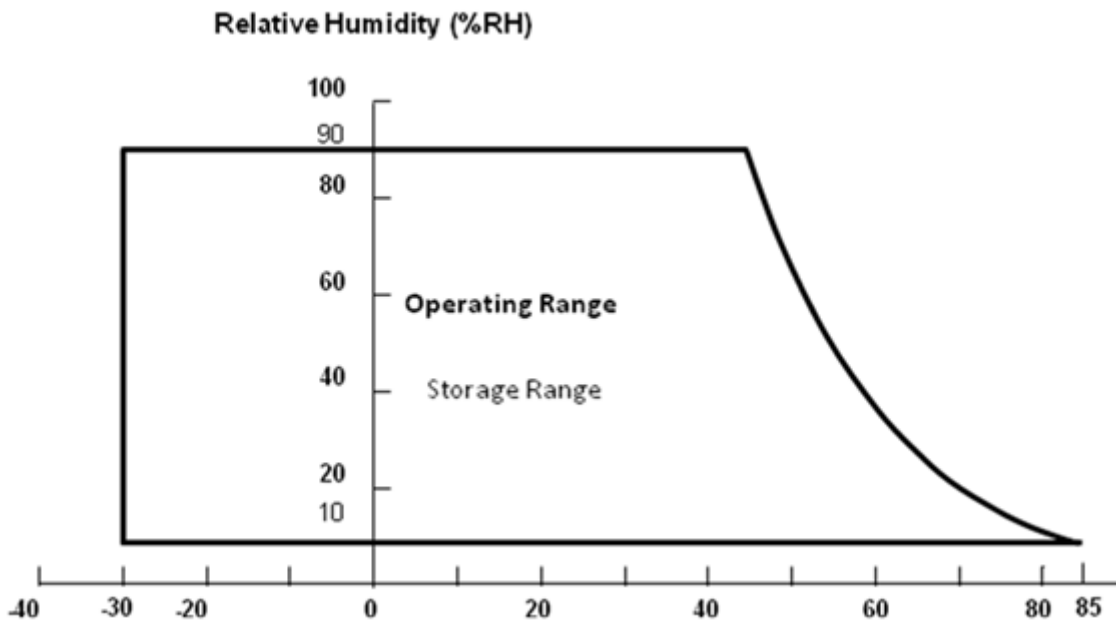

2.2 ELECTRICAL ABSOLUTE RATINGS

2.2.1 TFT LCD MODULE

Item	Symbol	Value		Unit	Note
		Min.	Max.		
Power Supply Voltage	V _{CC}	-0.3	4.0	V	(1)
Logic Input Voltage	V _{IN}	-0.3	4.0	V	

2.2.2 LED CONVERTER

Item	Symbol	Value		Unit	Note
		Min.	Max.		
Converter Voltage	V _i	-0.3	18	V	(1), (2)
Enable Voltage	EN	-0.3	5.5	V	
Backlight Adjust	ADJ	-0.3	5.5	V	

Note (1) Permanent damage to the device may occur if maximum values are exceeded. Function operation should be restricted to the conditions described under Normal Operating Conditions.

Note (2) Specified values are for LED light bar (Refer to 3.2 for further information).

3. ELECTRICAL CHARACTERISTICS

3.1 TFT LCD MODULE

Ta = 25 ± 2 °C

Parameter	Symbol	Value			Unit	Note	
		Min.	Typ.	Max.			
Power Supply Voltage	VCC	3.0	3.3	3.6	V	(1)	
Power Supply Ripple Voltage	VRP	-	-	100	mV		
Rush Current	IRUSH	-	-	4.0	A	(2)	
Power Supply Current	White	ICC	-	575	690	mA	(3)
	Black		-	445	535	mA	
Power Consumption	PL	-	1.9	2.28	W		
LVDS differential input voltage	Vid	100	-	600	mV		
LVDS common input voltage	Vic	1.0	1.2	1,4	V		
Logic High Input Voltage	VIH	2.3	-	VCC	V		
Logic Low Input Voltage	VIL	0	-	0.7	V		
LVDS terminating resistor	RT	-	100	-	ohm		

Note (1)The assembly should be always operated within above ranges.

Note (2)Measurement Conditions:

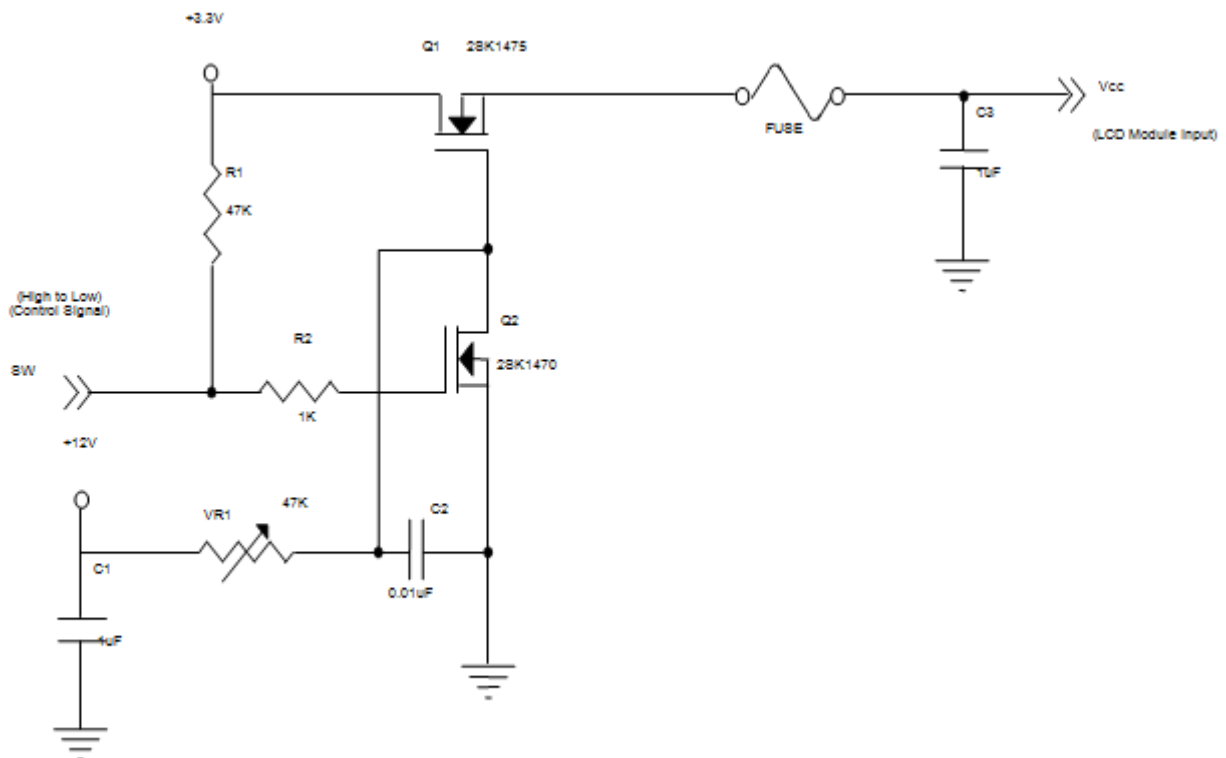

VCC rising time is 470us

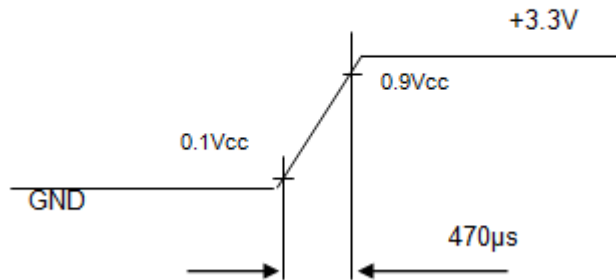

Note (3) The specified power supply current is under the conditions at $V_{cc} = 3.3\text{ V}$, $T_a = 25 \pm 2\text{ }^\circ\text{C}$, $f_v = 60\text{ Hz}$, whereas a power dissipation check pattern below is displayed.

a. White Pattern

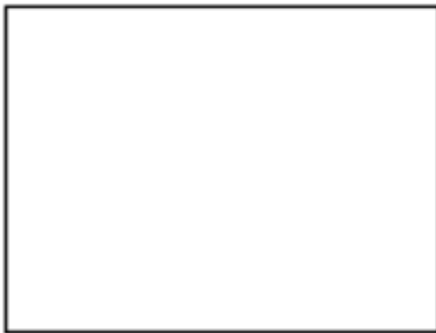

Active Area

b. Black Pattern



Active Area

3.2 BACKLIGHT UNIT

Parameter	Symbol	Value			Unit	Note	
		Min.	Typ.	Max.			
Converter Input Voltage	V_i	10.8	12.0	13.2	V	(Duty 100%)	
Converter Input Ripple Voltage	V_{iRP}	-	-	350	mV		
Converter Input Current	I_i	-	0.67	0.79	A	@ $V_i = 12V$ (Duty 100%)	
Converter Inrush Current	I_{iRUSH}	-	-	3.0	A	@ V_i rising time = 20ms ($V_i = 12V$)	
Input Power Consumption	PBL	-	8.2	9.5	W	(1)	
EN Control Level	Backlight on	ENLED	2.5	3.3	5.0	V	
	Backlight off	(BLON)	0	-	0.3	V	
PWM Control Level	PWM High Level	Dimming	2.5	3.3	5.0	V	
	PWM Low Level	(E_PWM)	0	-	0.15	V	
PWM Noise Range	VNoise	-	-	0.1	V		
PWM Control Frequency	fPWM	190	200	20k	Hz	(2)	
PWM Control Duty Ratio	-		5		100	%	(2), Suggestion @ 190Hz < f_{PWM} < 1kHz
			20	-	100	%	(2), @ 1kHz \leq f_{PWM} < 20kHz
LED Life Time	LL	50,000	-	-	Hrs	(3)	

Note (1) LED current is measured by utilizing a high frequency current meter as shown below:

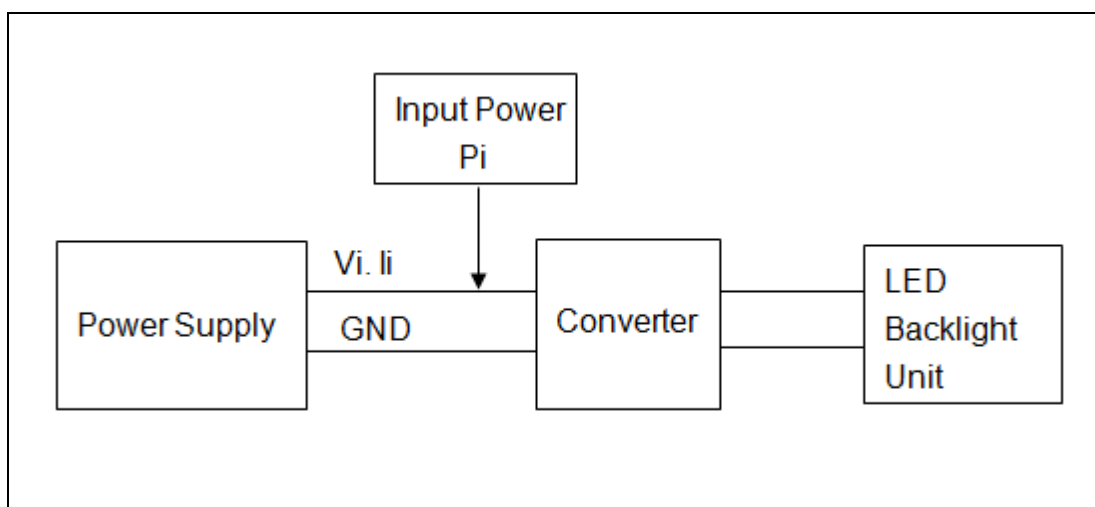

Note (2) At 190 ~1kHz PWM control frequency, duty ratio range is restricted from 5% to 100%.

1K ~20kHz PWM control frequency, duty ratio range is restricted from 20% to 100%.

If PWM control frequency is applied in the range from 1KHz to 20KHz, The “non-linear” phenomenon on the Backlight Unit may be found. So It’s a suggestion that PWM control frequency should be less than 1KHz.

Note (3) The lifetime of LED is estimated data and defined as the time when it continues to operate under the conditions at $T_a = 25 \pm 2 \text{ }^\circ\text{C}$ and Duty 100% until the brightness becomes $\leq 50\%$ of its original value. Operating LED at high temperature condition will reduce life time and lead to color shift.

4. BLOCK DIAGRAM

4.1 TFT LCD MODULE

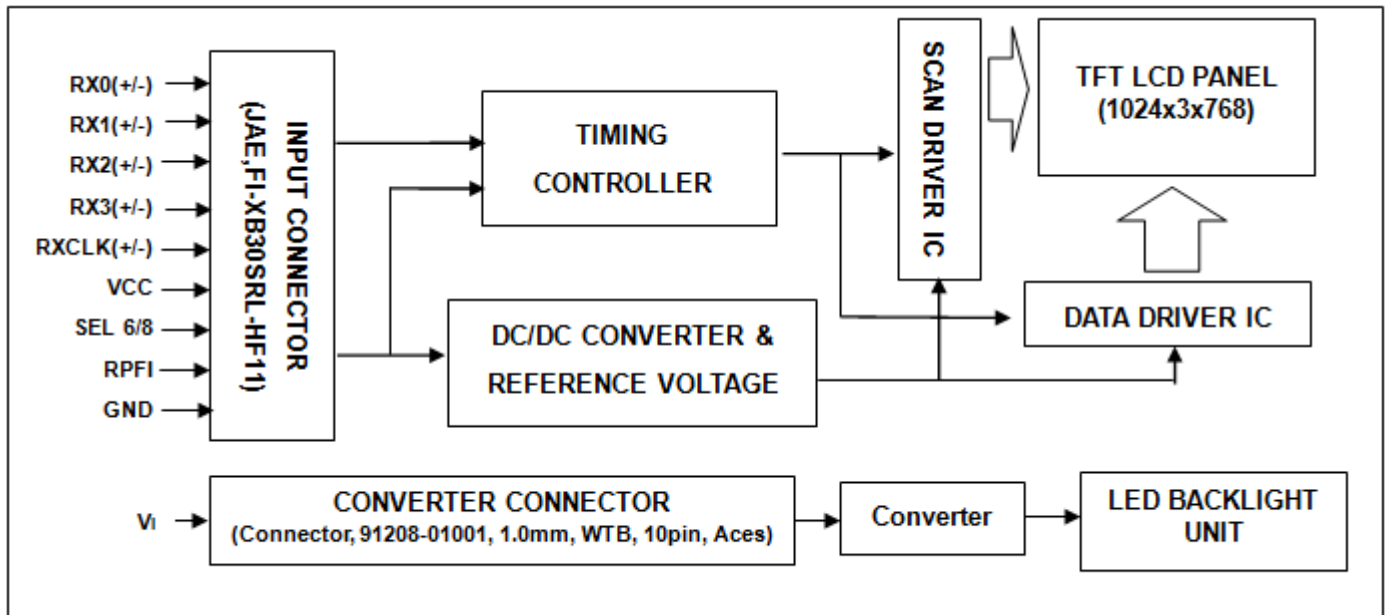

5. INTERFACE PIN ASSIGNMENT

5.1 TFT LCD MODULE

J1 Connector Pin Assignment

Pin No.	Symbol	Description	Note
1	VCC	Power supply: +3.3V	-
2	VCC	Power supply: +3.3V	-
3	VCC	Power supply: +3.3V	-
4	GND	Ground	-
5	GND	Ground	-
6	GND	Ground	-
7	RPFI	Reverse Panel Function (Display Rotation)	(3)
8	NC	No Connection	(4)
9	NC	No Connection	(4)
10	NC	No Connection	(4)
11	SEL6/8	LVDS 6/8 bit select function control, Low or NC → 8 bit Input Mode High → 6bit Input Mode	(3)
12	GND	Ground	-
13	NC	No Connection	(4)
14	GND	Ground	-
15	RX0-	Negative transmission data of pixel 0	-
16	RX0+	Positive transmission data of pixel 0	-
17	GND	Ground	-
18	RX1-	Negative transmission data of pixel 1	-
19	RX1+	Positive transmission data of pixel 1	-
20	GND	Ground	-
21	RX2-	Negative transmission data of pixel 2	-
22	RX2+	Positive transmission data of pixel 2	-
23	GND	Ground	-
24	RXCLK-	Negative of clock	-
25	RXCLK+	Positive of clock	-
26	GND	Ground	-
27	RX3-	Negative transmission data of pixel 3	-
28	RX3+	Positive transmission data of pixel 3	-
29	GND	Ground	-
30	NC	No Connection	(4)

Note (1) Connector Part No.: P-TWO 187106-30091 or STM, MSCK2407P30.D or equivalent.

Note (2) User's connector Part No.: JAE FI-X30H(L) or equivalent.

Note (3) "Low" stands for 0V. "High" stands for 3.3V. "NC" stands for "No Connected". The pin setting needs to be synchronized or leading with "Vcc".

Note (4) Pin8, Pin9, Pin10, Pin13, Pin30 input signals should be set to no connection or ground, this module would operate normally.

RPF1 pin:

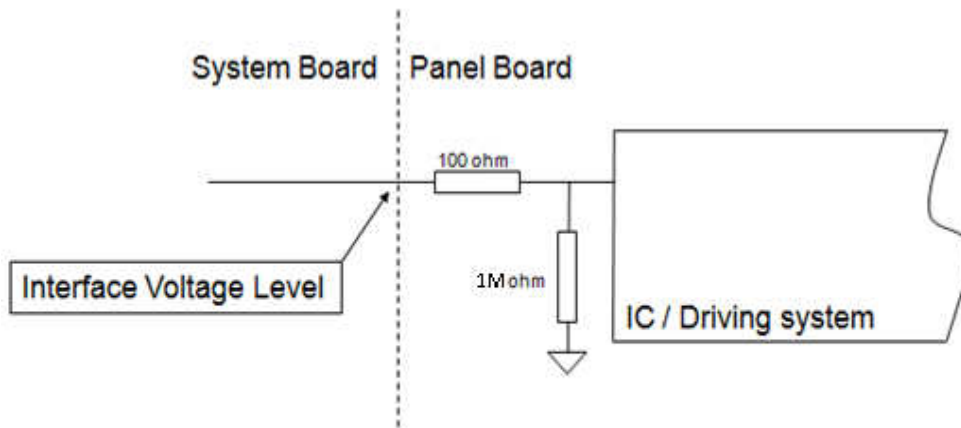

SEL6/8 pin:

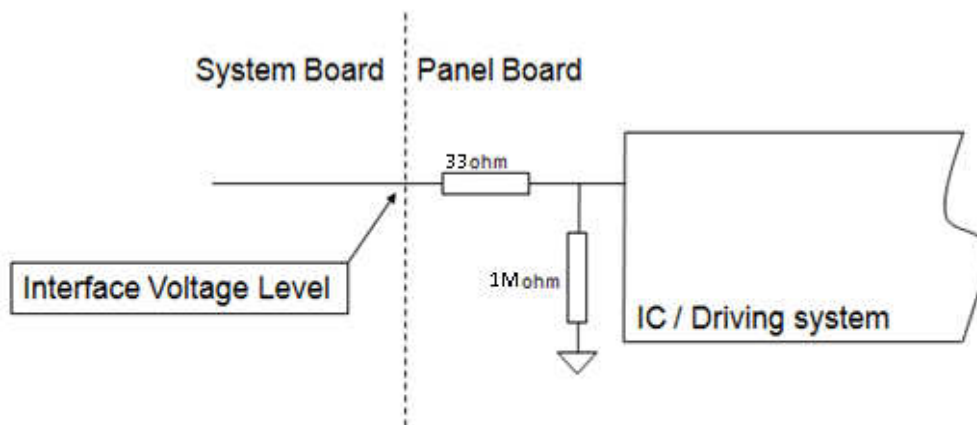

5.2 BACKLIGHT UNIT (CONVERTER CONNECTOR PIN)

Pin	Symbol	Description	Remark
1	V_i	Converter input voltage	12V
2	V_i	Converter input voltage	12V
3	V_i	Converter input voltage	12V
4	V_i	Converter input voltage	12V
5	V_{GND}	Converter ground	Ground
6	V_{GND}	Converter ground	Ground
7	V_{GND}	Converter ground	Ground
8	V_{GND}	Converter ground	Ground
9	EN	Enable pin	3.3V, Note (3)
10	ADJ	Backlight Adjust	PWM Dimming (190-210Hz, Hi: 3.3VDC, Lo: 0VDC) , Note (3)

Note (1) Connector Part No.: ACES,91208-01001-H01 or equivalent

Note (2) User's connector Part No.: ACES,91209-01011 or equivalent

Note (3) EN(BLON), ADJ(E_PWM) as shown below :

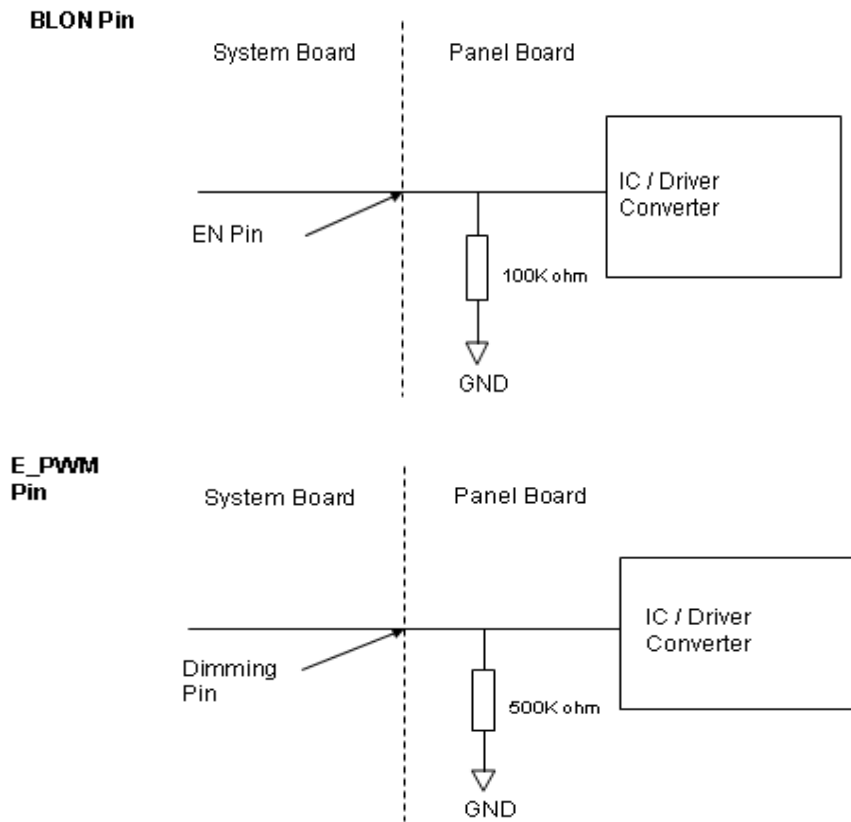

5.3 COLOR DATA INPUT ASSIGNMENT

The brightness of each primary color (red, green and blue) is based on the 6-bit gray scale data input for the color. The higher the binary input, the brighter the color. The table below provides the assignment of color.

Color		Data Signal																	
		Red						Green						Blue					
		R5	R4	R3	R2	R1	R0	G5	G4	G3	G2	G1	G0	B5	B4	B3	B2	B1	B0
Basic Colors	Black	0	0	0	0	0	0	0	0	0	0	0	0	0	0	0	0	0	0
	Red	1	1	1	1	1	1	0	0	0	0	0	0	0	0	0	0	0	0
	Green	0	0	0	0	0	0	1	1	1	1	1	1	0	0	0	0	0	0
	Blue	0	0	0	0	0	0	0	0	0	0	0	0	1	1	1	1	1	1
	Cyan	0	0	0	0	0	0	1	1	1	1	1	1	1	1	1	1	1	1
	Magenta	1	1	1	1	1	1	0	0	0	0	0	0	0	1	1	1	1	1
	Yellow	1	1	1	1	1	1	1	1	1	1	1	1	0	0	0	0	0	0
	White	1	1	1	1	1	1	1	1	1	1	1	1	1	1	1	1	1	1
Gray Scale Of Red	Red(0)/Dark	0	0	0	0	0	0	0	0	0	0	0	0	0	0	0	0	0	
	Red(1)	0	0	0	0	0	1	0	0	0	0	0	0	0	0	0	0	0	
	Red(2)	0	0	0	0	1	0	0	0	0	0	0	0	0	0	0	0	0	
	:	:	:	:	:	:	:	:	:	:	:	:	:	:	:	:	:	:	
	:	:	:	:	:	:	:	:	:	:	:	:	:	:	:	:	:	:	
	:	:	:	:	:	:	:	:	:	:	:	:	:	:	:	:	:	:	
	Red(61)	1	1	1	1	0	1	0	0	0	0	0	0	0	0	0	0	0	
	Red(62)	1	1	1	1	1	0	0	0	0	0	0	0	0	0	0	0	0	
Red(63)	1	1	1	1	1	1	0	0	0	0	0	0	0	0	0	0	0		
Gray Scale Of Green	Green(0)/Dark	0	0	0	0	0	0	0	0	0	0	0	0	0	0	0	0	0	
	Green(1)	0	0	0	0	0	0	0	0	0	0	0	1	0	0	0	0	0	
	Green(2)	0	0	0	0	0	0	0	0	0	0	1	0	0	0	0	0	0	
	:	:	:	:	:	:	:	:	:	:	:	:	:	:	:	:	:	:	
	:	:	:	:	:	:	:	:	:	:	:	:	:	:	:	:	:	:	
	:	:	:	:	:	:	:	:	:	:	:	:	:	:	:	:	:	:	
	Green(61)	0	0	0	0	0	0	1	1	1	1	0	1	0	0	0	0	0	
	Green(62)	0	0	0	0	0	0	1	1	1	1	1	0	0	0	0	0	0	
Green(63)	0	0	0	0	0	0	1	1	1	1	1	1	0	0	0	0	0		
Gray Scale Of Blue	Blue(0)/Dark	0	0	0	0	0	0	0	0	0	0	0	0	0	0	0	0	0	
	Blue(1)	0	0	0	0	0	0	0	0	0	0	0	0	0	0	0	0	1	
	Blue(2)	0	0	0	0	0	0	0	0	0	0	0	0	0	0	0	1	0	
	:	:	:	:	:	:	:	:	:	:	:	:	:	:	:	:	:	:	
	:	:	:	:	:	:	:	:	:	:	:	:	:	:	:	:	:	:	
	:	:	:	:	:	:	:	:	:	:	:	:	:	:	:	:	:	:	
	Blue(61)	0	0	0	0	0	0	0	0	0	0	0	0	1	1	1	1	0	
	Blue(62)	0	0	0	0	0	0	0	0	0	0	0	0	1	1	1	1	0	
Blue(63)	0	0	0	0	0	0	0	0	0	0	0	0	1	1	1	1	1		

Note (1) 0: Low Level Voltage, 1: High Level Voltage

The brightness of each primary color (red, green and blue) is based on the 8-bit gray scale data input for the color. The higher the binary input, the brighter the color. The table below provides the assignment of color versus data input.

Color		Data Signal																							
		Red								Green								Blue							
		R7	R6	R5	R4	R3	R2	R1	R0	G7	G6	G5	G4	G3	G2	G1	G0	B7	B6	B5	B4	B3	B2	B1	B0
Basic Colors	Black	0	0	0	0	0	0	0	0	0	0	0	0	0	0	0	0	0	0	0	0	0	0	0	0
	Red	1	1	1	1	1	1	1	1	0	0	0	0	0	0	0	0	0	0	0	0	0	0	0	0
	Green	0	0	0	0	0	0	0	0	1	1	1	1	1	1	1	1	0	0	0	0	0	0	0	0
	Blue	0	0	0	0	0	0	0	0	0	0	0	0	0	0	0	0	1	1	1	1	1	1	1	1
	Cyan	0	0	0	0	0	0	0	0	1	1	1	1	1	1	1	1	1	1	1	1	1	1	1	1
	Magenta	1	1	1	1	1	1	1	1	0	0	0	0	0	0	0	0	1	1	1	1	1	1	1	1
	Yellow	1	1	1	1	1	1	1	1	1	1	1	1	1	1	1	1	0	0	0	0	0	0	0	0
	White	1	1	1	1	1	1	1	1	1	1	1	1	1	1	1	1	1	1	1	1	1	1	1	1
Gray Scale Of Red	Red(0) / Dark	0	0	0	0	0	0	0	0	0	0	0	0	0	0	0	0	0	0	0	0	0	0	0	
	Red(1)	0	0	0	0	0	0	0	1	0	0	0	0	0	0	0	0	0	0	0	0	0	0	0	
	Red(2)	0	0	0	0	0	0	1	0	0	0	0	0	0	0	0	0	0	0	0	0	0	0	0	
	⋮	⋮	⋮	⋮	⋮	⋮	⋮	⋮	⋮	⋮	⋮	⋮	⋮	⋮	⋮	⋮	⋮	⋮	⋮	⋮	⋮	⋮	⋮	⋮	
	⋮	⋮	⋮	⋮	⋮	⋮	⋮	⋮	⋮	⋮	⋮	⋮	⋮	⋮	⋮	⋮	⋮	⋮	⋮	⋮	⋮	⋮	⋮	⋮	
	Red(253)	1	1	1	1	1	1	0	1	0	0	0	0	0	0	0	0	0	0	0	0	0	0	0	
	Red(254)	1	1	1	1	1	1	1	0	0	0	0	0	0	0	0	0	0	0	0	0	0	0	0	
	Red(255)	1	1	1	1	1	1	1	1	0	0	0	0	0	0	0	0	0	0	0	0	0	0	0	
Gray Scale Of Green	Green(0) / Dark	0	0	0	0	0	0	0	0	0	0	0	0	0	0	0	0	0	0	0	0	0	0	0	
	Green(1)	0	0	0	0	0	0	0	0	0	0	0	0	0	0	1	0	0	0	0	0	0	0	0	
	Green(2)	0	0	0	0	0	0	0	0	0	0	0	0	0	1	0	0	0	0	0	0	0	0	0	
	⋮	⋮	⋮	⋮	⋮	⋮	⋮	⋮	⋮	⋮	⋮	⋮	⋮	⋮	⋮	⋮	⋮	⋮	⋮	⋮	⋮	⋮	⋮	⋮	
	⋮	⋮	⋮	⋮	⋮	⋮	⋮	⋮	⋮	⋮	⋮	⋮	⋮	⋮	⋮	⋮	⋮	⋮	⋮	⋮	⋮	⋮	⋮	⋮	
	Green(253)	0	0	0	0	0	0	0	0	1	1	1	1	1	1	0	1	0	0	0	0	0	0	0	
	Green(254)	0	0	0	0	0	0	0	0	1	1	1	1	1	1	1	0	0	0	0	0	0	0	0	
	Green(255)	0	0	0	0	0	0	0	0	1	1	1	1	1	1	1	1	0	0	0	0	0	0	0	
Gray Scale Of Blue	Blue(0) / Dark	0	0	0	0	0	0	0	0	0	0	0	0	0	0	0	0	0	0	0	0	0	0	0	
	Blue(1)	0	0	0	0	0	0	0	0	0	0	0	0	0	0	0	0	0	0	0	0	0	0	1	
	Blue(2)	0	0	0	0	0	0	0	0	0	0	0	0	0	0	0	0	0	0	0	0	0	0	1	
	⋮	⋮	⋮	⋮	⋮	⋮	⋮	⋮	⋮	⋮	⋮	⋮	⋮	⋮	⋮	⋮	⋮	⋮	⋮	⋮	⋮	⋮	⋮	⋮	
	⋮	⋮	⋮	⋮	⋮	⋮	⋮	⋮	⋮	⋮	⋮	⋮	⋮	⋮	⋮	⋮	⋮	⋮	⋮	⋮	⋮	⋮	⋮	⋮	
	Blue(253)	0	0	0	0	0	0	0	0	0	0	0	0	0	0	0	1	1	1	1	1	1	1	0	
	Blue(254)	0	0	0	0	0	0	0	0	0	0	0	0	0	0	0	1	1	1	1	1	1	1	0	
	Blue(255)	0	0	0	0	0	0	0	0	0	0	0	0	0	0	0	1	1	1	1	1	1	1	1	

Note (1) 0: Low Level Voltage, 1: High Level Voltage

6. INTERFACE TIMING

6.1 INPUT SIGNAL TIMING SPECIFICATIONS

The input signal timing specifications are shown as the following table and timing diagram.

Signal	Item	Symbol	Min.	Typ.	Max.	Unit	Note
LVDS Clock	Frequency	F_c	57.7	65	73.6	MHz	-
	Period	T_c	13.6	15.4	17.3	ns	
	Input cycle to cycle jitter	T_{rd}	---	---	200	ns	(a)
	Input Clock to data skew	TLVCCS	$-0.02 \cdot T_c$	---	$0.02 \cdot T_c$	ps	(b)
	Spread spectrum modulation range	F_{clkin_mod}	$0.987 \cdot F_c$	---	$1.013 \cdot F_c$	MHz	(c)
	Spread spectrum modulation frequency	F_{SSM}	---	---	200	KHz	
	High Time	T_{ch}	---	4/7	---	T_{ch}	
	Low Time	T_{cl}	---	3/7	---	T_{ch}	
Vertical Display Term	Frame Rate	Fr	---	60	---	Hz	$T_v = T_{vd} + T_{vb}$
	Total	T_v	776	806	838	Th	-
	Active Display	T_{vd}	768	768	768	Th	-
	Blank	T_{vb}	8	38	70	Th	-
Horizontal Display Term	Total	T_h	1240	1344	1464	Tc	$T_h = T_{hd} + T_{hb}$
	Active Display	T_{hd}	1024	1024	1024	Tc	-
	Blank	T_{hb}	216	320	440	Tc	-

Note (1) Because this module is operated by DE only mode, Hsync and Vsync input signals should be set to low logic level or ground. Otherwise, this module would operate abnormally.

Note (2) The $T_v(T_{vd} + T_{vb})$ must be integer, otherwise, the module would operate abnormally.

INPUT SIGNAL TIMING DIAGRAM

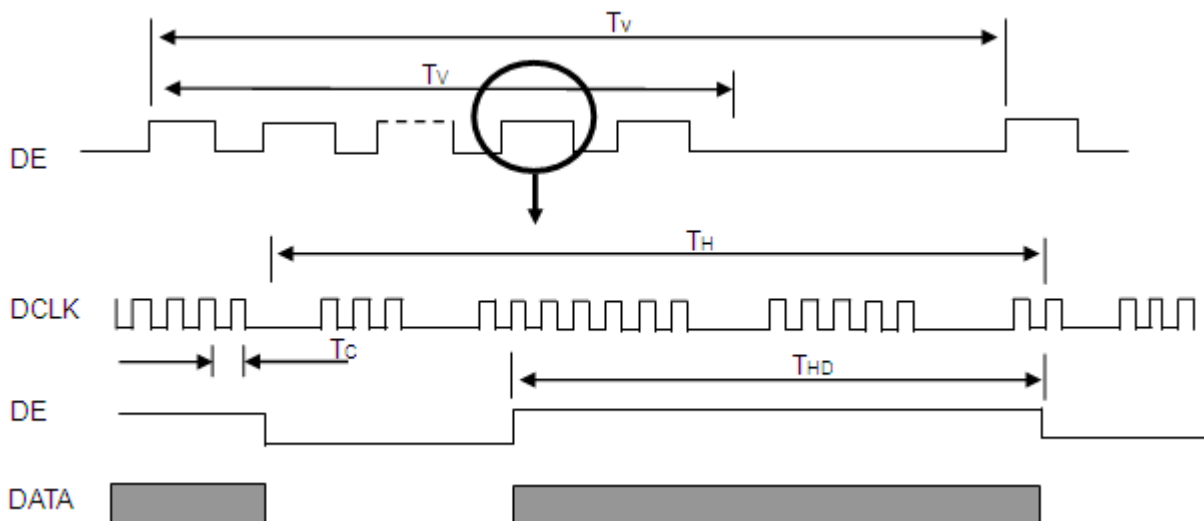

TIMING DIAGRAM of LVDS

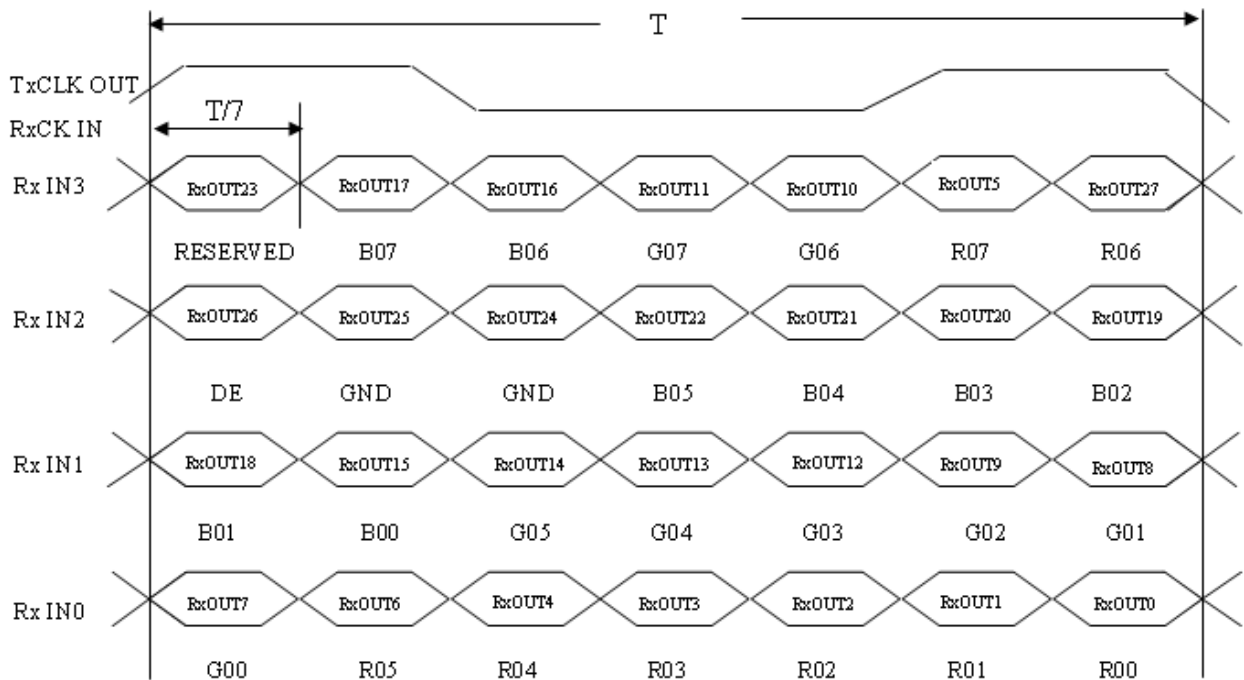

Note (a) The input clock cycle-to-cycle jitter is defined as below figures. $Trcl = |T_1 - T|$

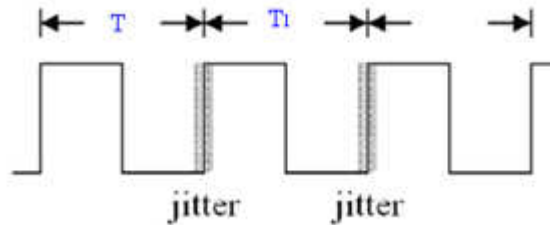

Note (b) Input Clock to data skew is defined as below figures.

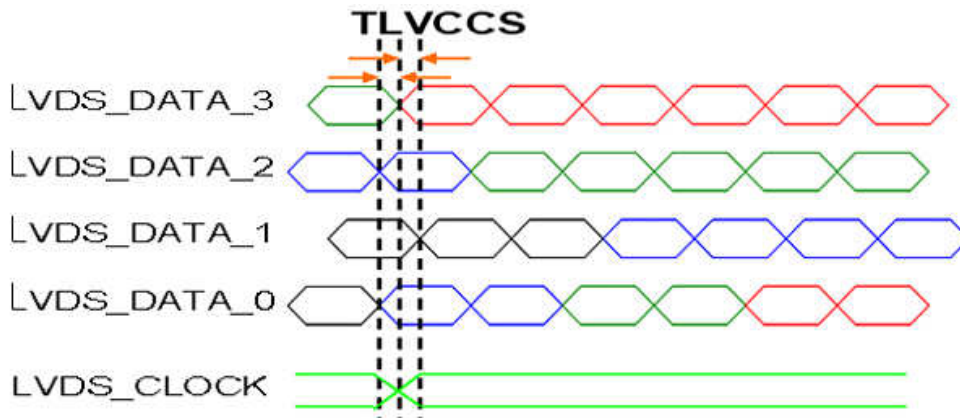

Note (c) The SSCG (Spread spectrum clock generator) is defined as below figures.

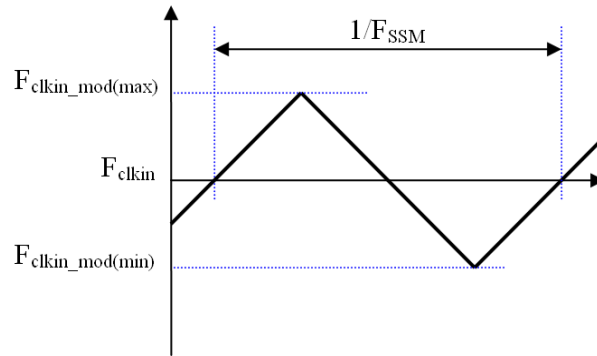

6.2 POWER ON/OFF SEQUENCE

To prevent a latch-up or DC operation of LCD assembly, the power on/off sequence should be as the diagram below.

Power ON/OFF sequence

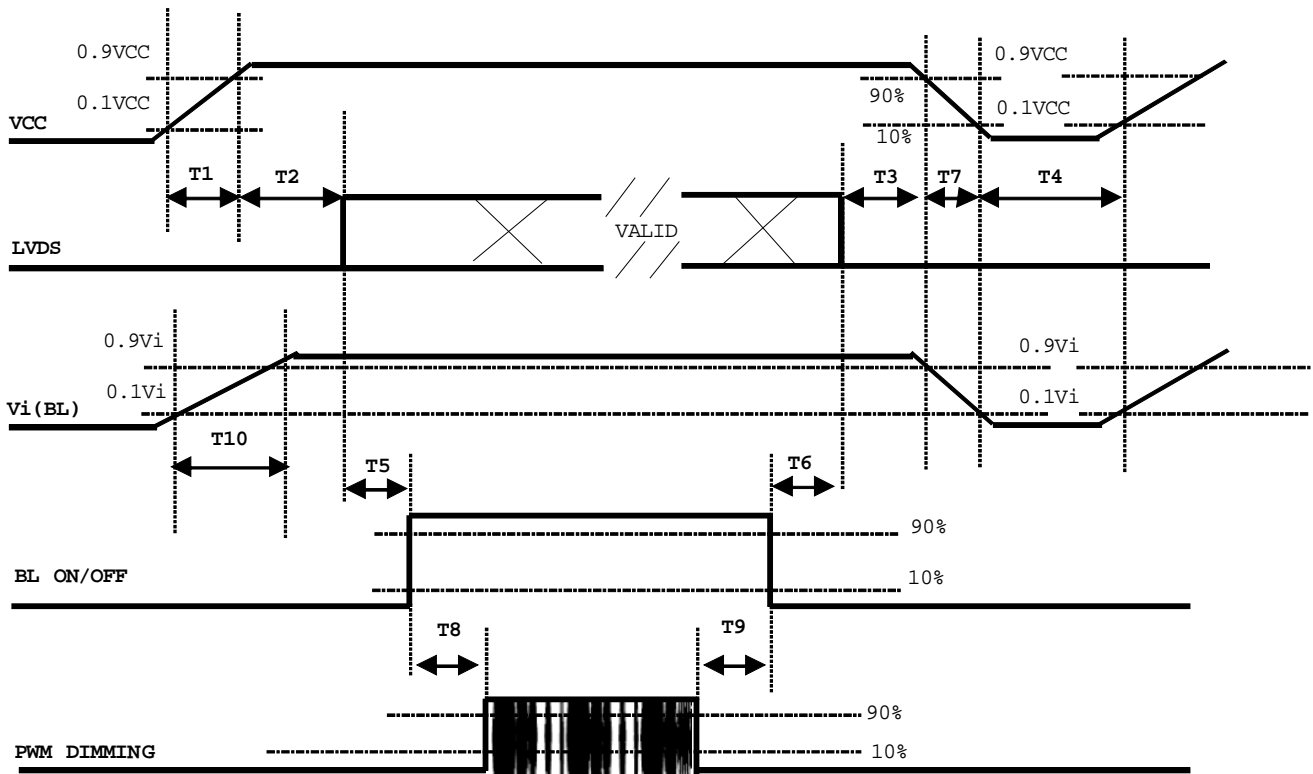

Note:

- (1) The supply voltage of the external system for the module input should be the same as the definition of Vcc.
- (2) When the backlight turns on before the LCD operation of the LCD turns off, the display may momentarily become abnormal screen.
- (3) In case of VCC = off level, please keep the level of input signals on the low or keep a high impedance.
- (4) T4 should be measured after the module has been fully discharged between power off and on period.
- (5) Interface signal shall not be kept at high impedance when the power is on.
- (6) INX won't take any responsibility for the products which are damaged by the customers not following the Power Sequence.
- (7) There might be slight electronic noise when LCD is turned off (even backlight unit is also off). To avoid this symptom, we suggest "Vcc falling timing" to follow "T7 spec".

Parameter	Value			Units
	Min	Typ	Max	
T1	0.5	---	10	ms
T2	0	---	50	ms
T3	0	---	50	ms
T4	500	---	---	ms
T5	450	---	---	ms
T6	200	---	---	ms
T7	10	---	100	ms
T8	10	---	---	ms
T9	10	---	---	ms
T10	20	---	50	ms

6.3 THE INPUT DATA FORMAT

SEL 6/8 = "High" for 6 bits LVDS Input

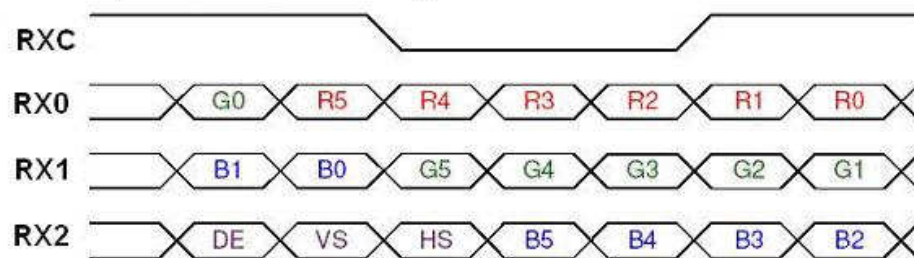

SEL 6/8 = "Low" or "NC" for 8 bits LVDS Input

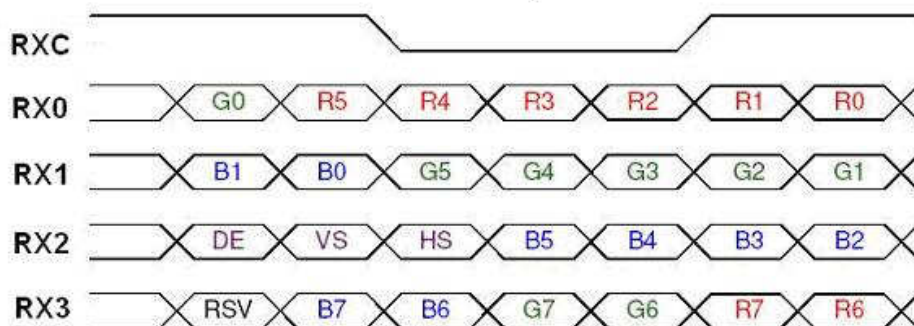

Note (1) R/G/B data 7: MSB, R/G/B data 0: LSB

Note (2) Please follow PSWG

Signal Name	Description	Remark
R7 R6 R5 R4 R3 R2 R1 R0	Red Data 7 (MSB) Red Data 6 Red Data 5 Red Data 4 Red Data 3 Red Data 2 Red Data 1 Red Data 0 (LSB)	Red-pixel Data Each red pixel's brightness data consists of these 8 bits pixel data.
G7 G6 G5 G4 G3 G2 G1 G0	Green Data 7 (MSB) GreenData 6 GreenData 5 GreenData 4 GreenData 3 GreenData 2 GreenData 1 GreenData 0 (LSB)	Green-pixel Data Each green pixel's brightness data consists of these 8 bits pixel data.
B7 B6 B5 B4 B3 B2 B1 B0	Blue Data 7 (MSB) Blue Data 6 Blue Data 5 Blue Data 4 Blue Data 3 Blue Data 2 Blue Data 1 Blue Data 0 (LSB)	Blue-pixel Data Each blue pixel's brightness data consists of these 8 bits pixel data.
RXCLKIN+ RXCLKIN-	LVDS Clock Input	
DE	Display Enable	
VS	Vertical Sync	
HS	Horizontal Sync	

6.4 SCANNING DIRECTION

The following figures show the image see from the front view. The arrow indicates the direction of scan.

Fig.1 Normal Scan



PCBA on the top side

Fig.2 Reverse Scan



PCBA on the top side

Fig. 1 Normal scan (pin 7, RPFI = Low or NC)

Fig. 2 Reverse scan (pin 7, RPFI = High)

7. OPTICAL CHARACTERISTICS

7.1 TEST CONDITIONS

Item	Symbol	Value	Unit
Ambient Temperature	Ta	25±2	oC
Ambient Humidity	Ha	50±10	%RH
Supply Voltage	According to typical value and tolerance in "ELECTRICAL CHARACTERISTICS"		
Input Signal			
PWM Duty Ratio	D	100	%

7.2 OPTICAL SPECIFICATIONS

The relative measurement methods of optical characteristics are shown here and all items are measured at the center point of screen unless otherwise noted. The following items should be measured under the test conditions described above and stable conditions shown in Note (5).

Item		Symbol	Condition	Min.	Typ.	Max.	Unit	Note
Color Chromaticity	Red	Rx	$\theta X=0^\circ, \theta Y=0^\circ$ Grayscale Maximum	0.599	0.649	0.699	-	(1), (5)
		Ry		0.290	0.340	0.390		
	Green	Gx		0.270	0.320	0.370		
		Gy		0.556	0.606	0.656		
	Blue	Bx		0.099	0.149	0.199		
		By		0.005	0.055	0.105		
	White	Wx		0.263	0.313	0.363		
		Wy		0.279	0.329	0.379		
Center Luminance of White		LC		800	1000	-	nits	(4), (5)
Contrast Ratio		CR		700	1000	-		(2), (5)
Response Time		TR	$\theta X=0^\circ, \theta Y=0^\circ$	-	13	18	-	(3)
		TF		-	12	17	-	
White Variation		δW	$\theta X=0^\circ, \theta Y=0^\circ$	72	80	-	%	(5), (6)
Viewing Angle	Horizontal	$\theta X+$	$CR \geq 10$	80	88	-	Deg.	(1), (5)
		$\theta X-$		80	88	-		
	Vertical	$\theta Y+$		80	88	-		
		$\theta Y-$		80	88	-		

Definition :

Grayscale Maximum : Grayscale 255 (10 bits: grayscale 1023 ; 8 bits : grayscale 255 ; 6 bits: grayscale 63)

White : Luminance of Grayscale Maximum (All R,G,B)

Black : Luminance of grayscale 0 (All R,G,B)

Note (1) Definition of Viewing Angle (θ_x, θ_y):

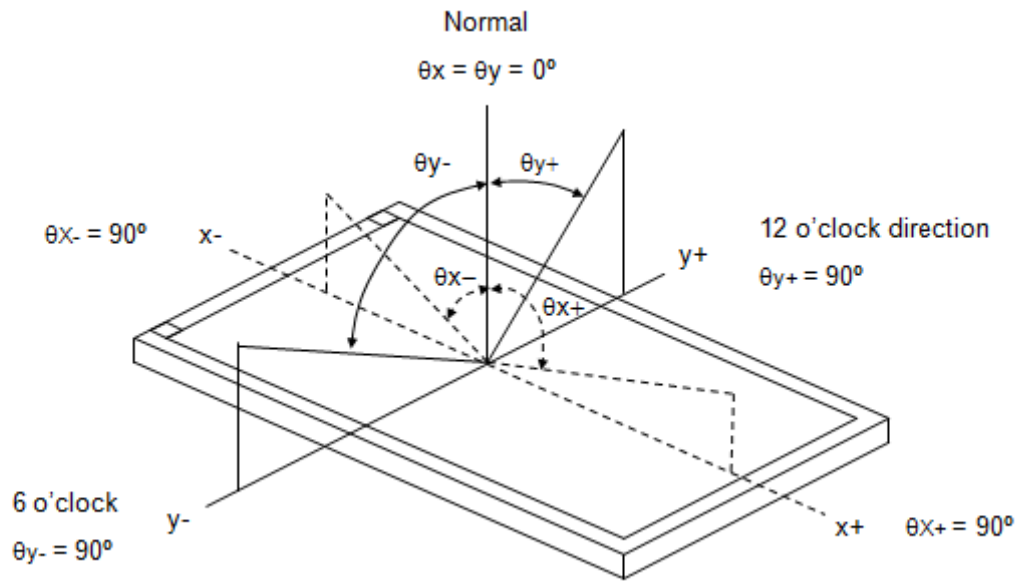

Note (2) Definition of Contrast Ratio (CR):

The contrast ratio can be calculated by the following expression at center point.

$$\text{Contrast Ratio (CR)} = \text{White} / \text{Black}$$

Note (3) Definition of Response Time (T_R, T_F)

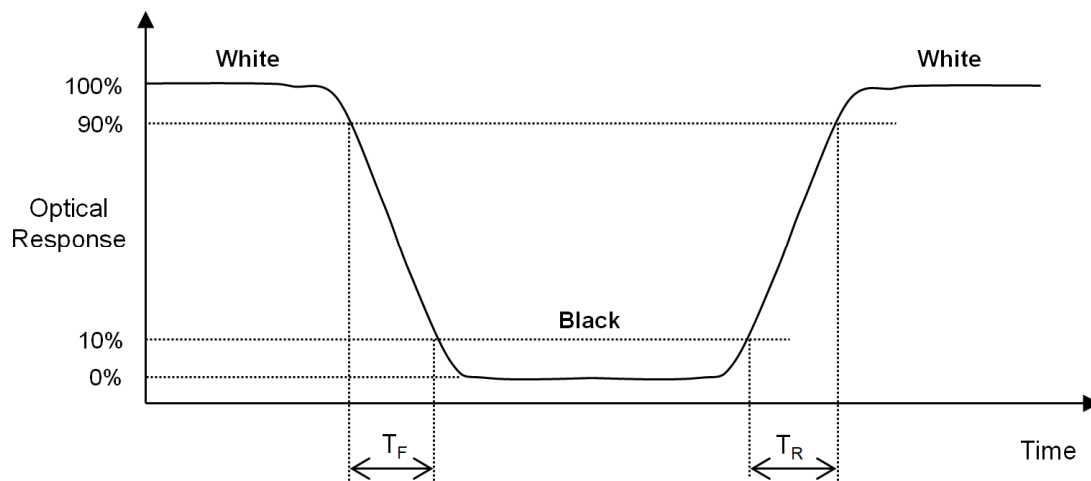

Note (4) Definition of Luminance of White (L_c):

Measure the luminance of White at center point.

Note (5) Measurement Setup:

The LCD module should be stabilized at given temperature to avoid abrupt temperature change during measuring. In order to stabilize the luminance, the measurement should be executed after lighting Backlight for 40 minutes in a windless room. The measurement placement of module should be in accordance with module drawing.

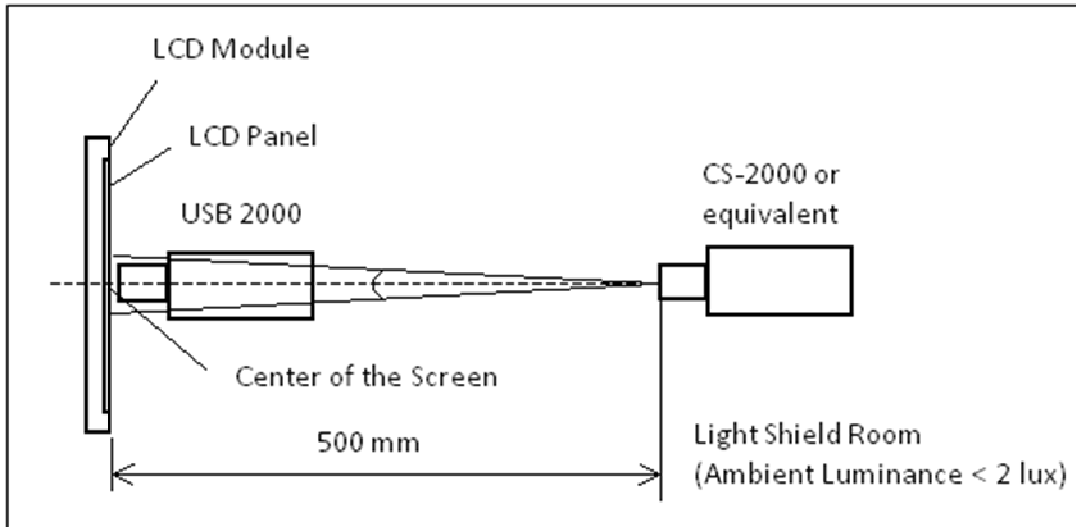

Note (6) Definition of White Variation (δW):

Measure the luminance of White at 5 points.

Luminance of White : $L(X)$, where X is from 1 to 5.

$$\delta W = \frac{\text{Minimum [L(1) to L(5)]}}{\text{Maximum [L(1) to L(5)]}} \times 100\%$$

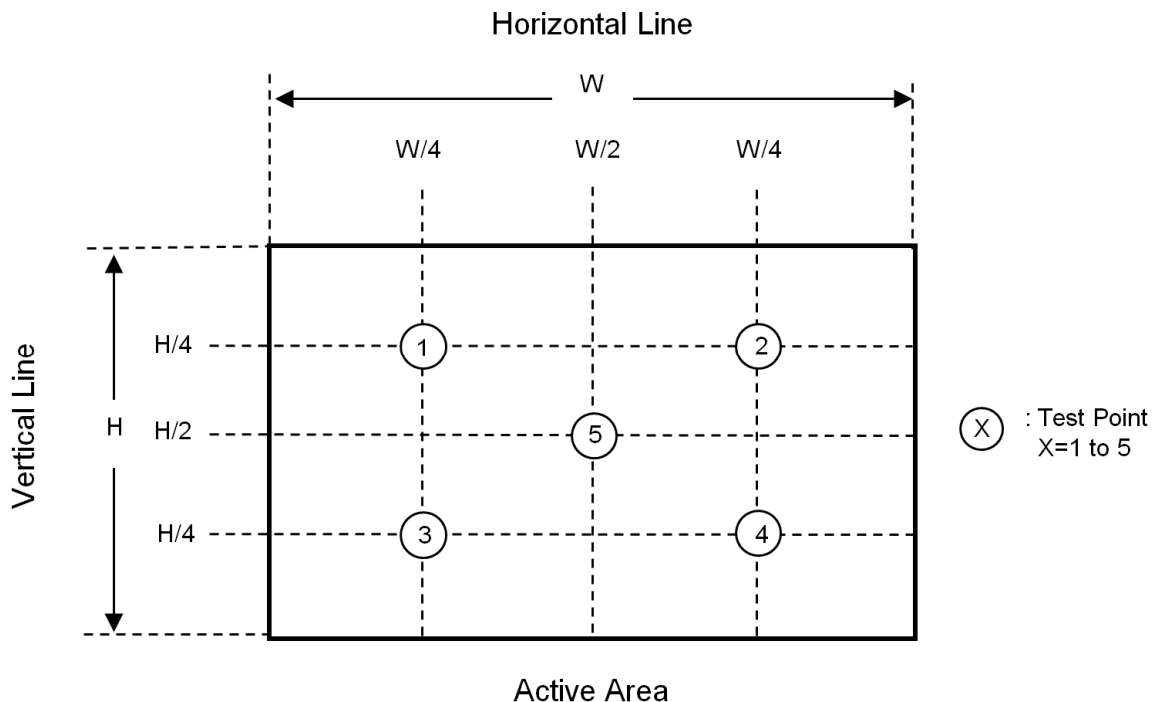

8. RELIABILITY TEST CRITERIA

Test Item	Test Condition	Note
High Temperature Storage Test	85°C, 240 hours	(1),(2) (4),(5)
Low Temperature Storage Test	-30°C, 240 hours	
Thermal Shock Storage Test	-20°C, 0.5hour \longleftrightarrow 70°C, 0.5hour; 100cycles, 1hour/cycle	
High Temperature Operation Test	85°C, 240 hours	
Low Temperature Operation Test	-30°C, 240 hours	
High Temperature & High Humidity Operation Test	50°C, 80%RH, 240hours	
ESD Test (Operation)	150pF, 330 Ω , 1 sec/cycle Condition 1 : panel contact, \pm 8 KV Condition 2 : panel non-contact \pm 15 KV	(1),(4)
Shock (Non-Operating)	5G, 11ms, half sine wave, 1 time for \pm X, \pm Y, \pm Z direction	(2),(3)
Vibration (Non-Operating)	1.5G, 10 ~ 300 Hz sine wave, 10 min/cycle, 3 cycles each X, Y, Z direction	

Note(1) There should be no condensation on the surface of panel during test ,

Note(2) Temperature of panel display surface area should be 90°C Max.

Note(3) At testing Vibration and Shock, the fixture in holding the module has to be hard and rigid enough so that the module would not be twisted or bent by the fixture.

Note(4) In the standard conditions, there is no function failure issue occurred. All the cosmetic specification is judged before reliability test.

Note(5) Before cosmetic and function test, the product must have enough recovery time, at least 24 hours at room temperature.

9. PACKAGING

9.1 PACKING SPECIFICATIONS

- (1) 24pcs LCD modules / 1 Box
- (2) Box dimensions: 490 (L) X 350 (W) X 320 (H) mm
- (3) Weight: approximately 13.1 Kg (24 modules per box)

9.2 PACKING METHOD

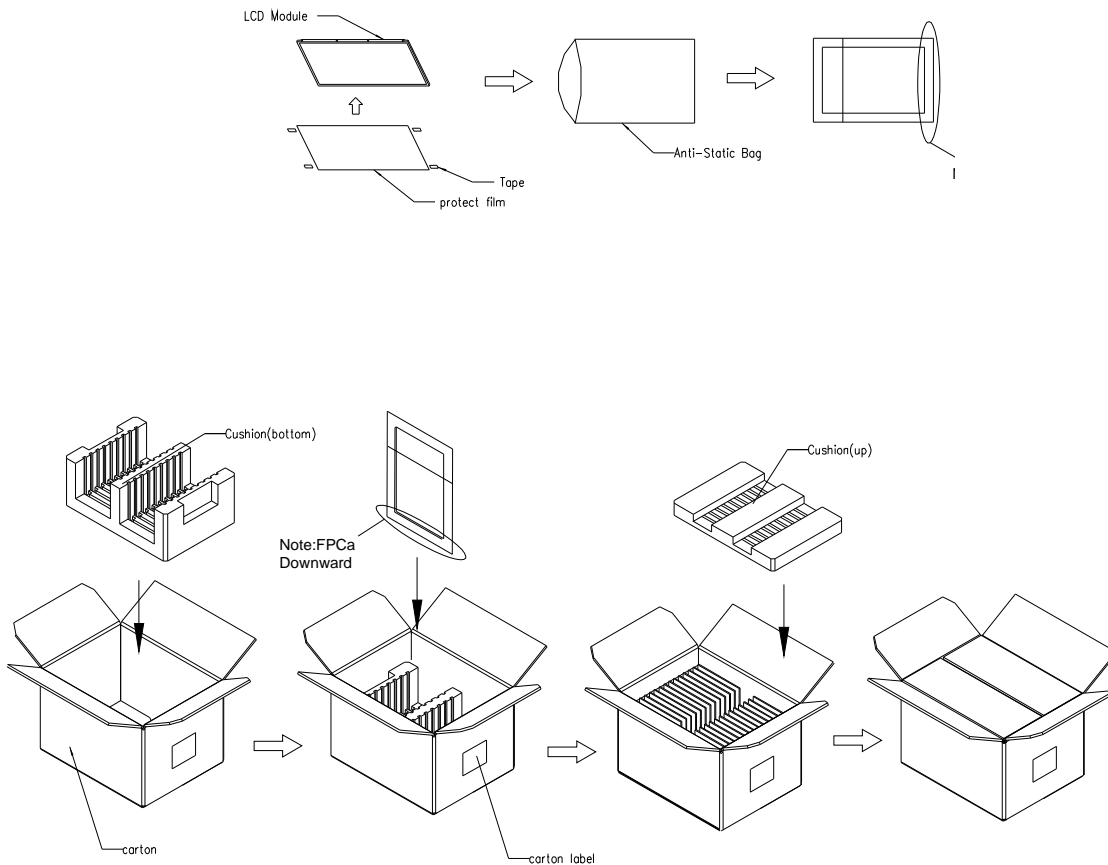

Figure.9-1 packing method

Sea & Land Transportation

Air Transportation

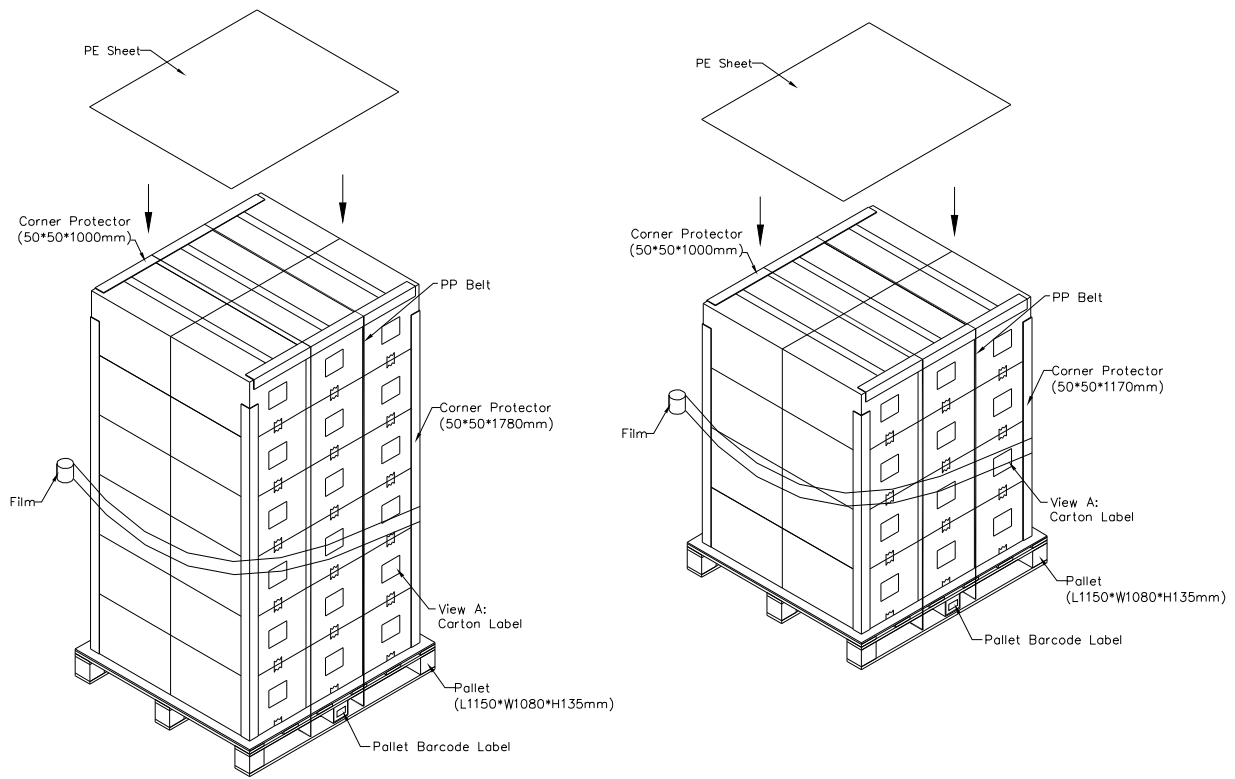

Figure. 9-2 Packing method

9.3 UN-PACKING METHOD

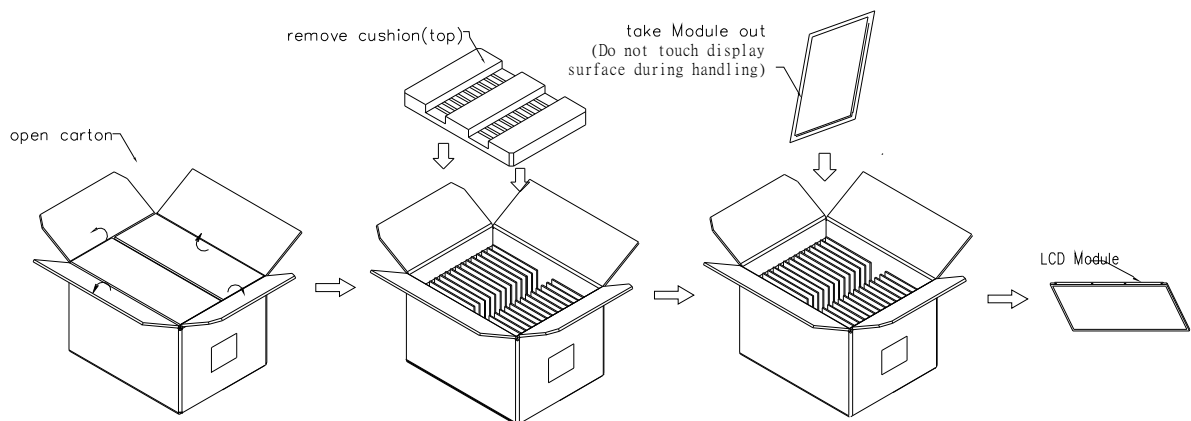
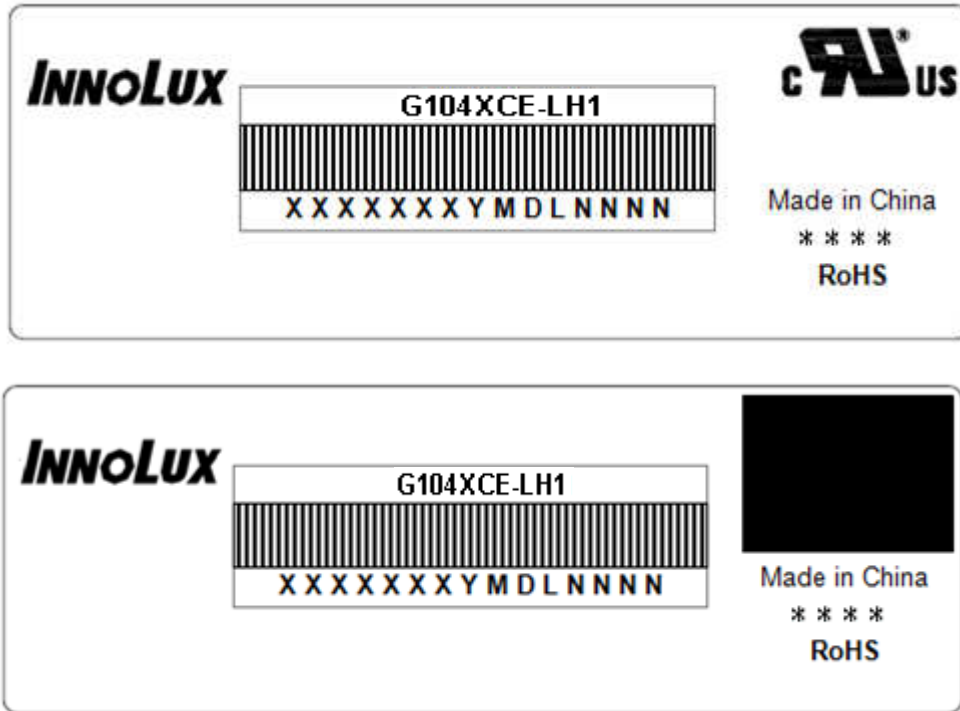

Figure. 9-3 UN-Packing method

10. DEFINITION OF LABELS

10.1 INNOLUX MODULE LABEL

The barcode nameplate is pasted on each module as illustration, and its definitions are as following explanation.



Note (1) Safety Compliance(UL logo) will open after C1 version.

(a) Model Name: G104XCE-L01

(b) * * * * : Factory ID

(c) Serial ID: X X X X X X Y M D X N N N N

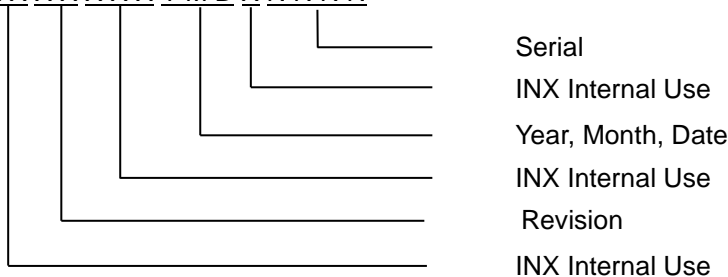

Serial ID includes the information as below:

- (a) Manufactured Date: Year: 1~9, for 2021~2029
Month: 1~9, A~C, for Jan. ~ Dec.
Day: 1~9, A~Y, for 1st to 31st, exclude I , O and U
- (b) Revision Code: cover all the change
- (c) Serial No.: Manufacturing sequence of product

11. PRECAUTIONS

11.1 ASSEMBLY AND HANDLING PRECAUTIONS

- (1) The module should be assembled into the system firmly by using every mounting hole. Be careful not to twist or bend the module.
- (2) While assembling or installing modules, it can only be in the clean area. The dust and oil may cause electrical short or damage the polarizer.
- (3) Use fingerstalls or soft gloves in order to keep display clean during the incoming inspection and assembly process.
- (4) Do not press or scratch the surface harder than a HB pencil lead on the panel because the polarizer is very soft and easily scratched.
- (5) If the surface of the polarizer is dirty, please clean it by some absorbent cotton or soft cloth. Do not use Ketone type materials (ex. Acetone), Ethyl alcohol, Toluene, Ethyl acid or Methyl chloride. It might permanently damage the polarizer due to chemical reaction.
- (6) Wipe off water droplets or oil immediately. Staining and discoloration may occur if they left on panel for a long time.
- (7) If the liquid crystal material leaks from the panel, it should be kept away from the eyes or mouth. In case of contacting with hands, legs or clothes, it must be washed away thoroughly with soap.
- (8) Protect the module from static electricity, it may cause damage to the C-MOS Gate Array IC.
- (9) Do not disassemble the module.
- (10) Do not pull or fold the lamp wire.
- (11) Pins of I/F connector should not be touched directly with bare hands.

11.2 STORAGE PRECAUTIONS

- (1) When storing for a long time, the following precautions are necessary.
 - (a) Store them in a dark place. Do not expose the module to sunlight or fluorescent light. Keep the temperature between 5°C and 30°C at humidity 50+-10%RH.
 - (b) The polarizer surface should not come in contact with any other object.
 - (c) It is recommended that they be stored in the container in which they were shipped.
 - (d) Storage condition is guaranteed under packing conditions.
 - (e) The phase transition of Liquid Crystal in the condition of the low or high storage temperature will be recovered when the LCD module returns to the normal condition
- (2) High temperature or humidity may reduce the performance of module. Please store LCD module within the specified storage conditions.
- (3) It is dangerous that moisture come into or contacted the LCD module, because the moisture may damage LCD module when it is operating.
- (4) It may reduce the display quality if the ambient temperature is lower than 10 °C. For example, the response time will become slowly, and the starting voltage of lamp will be higher than the room temperature.

11.3 OTHER PRECAUTIONS

- (1) Normal operating condition
 - (a) Display pattern: dynamic pattern (Real display)
 - (Note) Long-term static display can cause image sticking.
- (2) Operating usages to protect against image sticking due to long-term static display
 - (a) Suitable operating time: under 16 hours a day.
 - (b) Static information display recommended to use with moving image.
 - (c) Cycling display between 5 minutes' information(static) display and 10 seconds' moving image.
- (3) Abnormal condition just means conditions except normal condition.

12. MECHANICAL CHARACTERISTIC

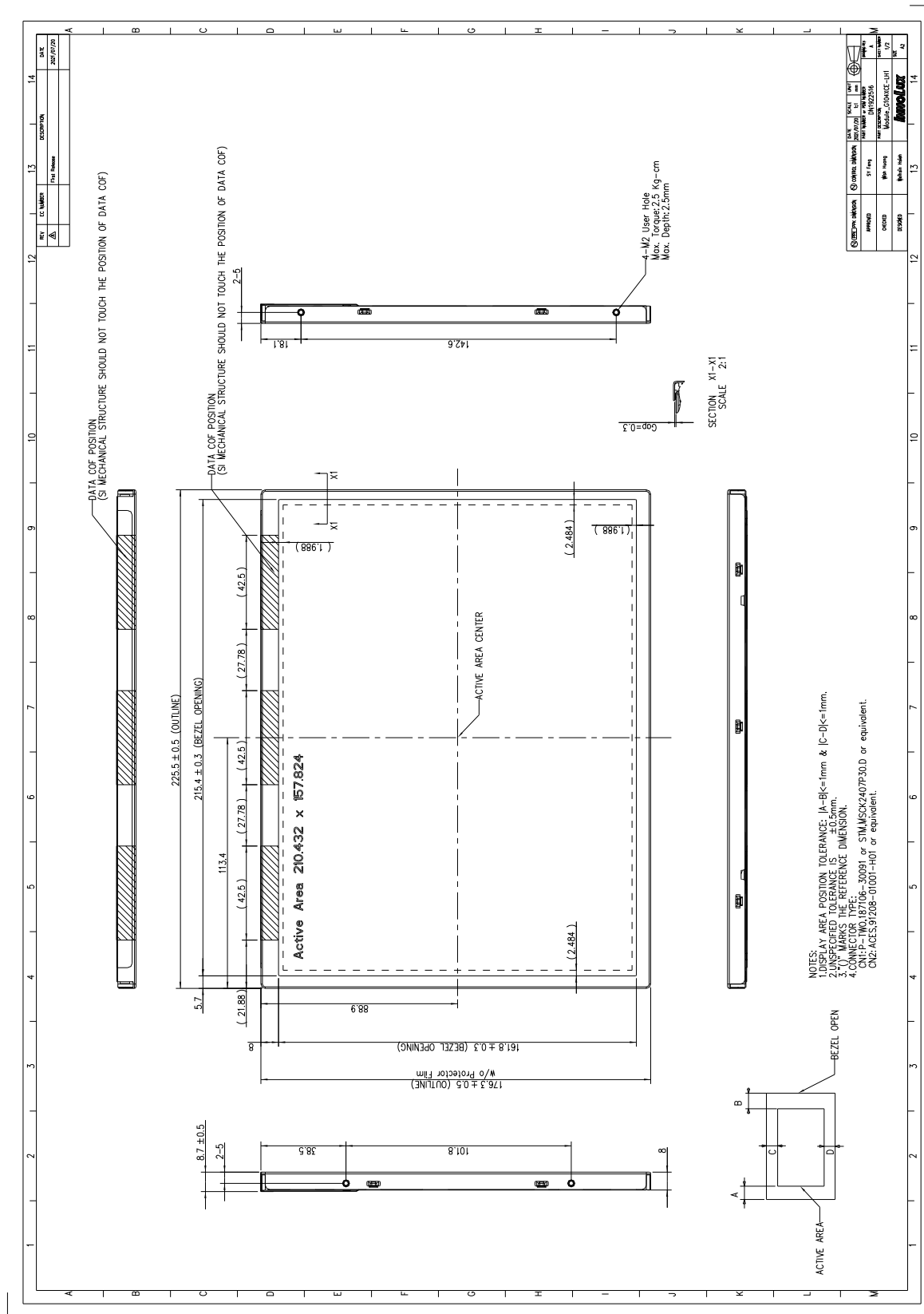

Customer/Model	Part Number	Rev.	ECN/Change	DATE
STI/STI	STI/STI	1.0		2017/07/25
Customer/Model	Part Number	Rev.	ECN/Change	DATE
INNOLUX	INNOLUX	1.0		2017/07/25

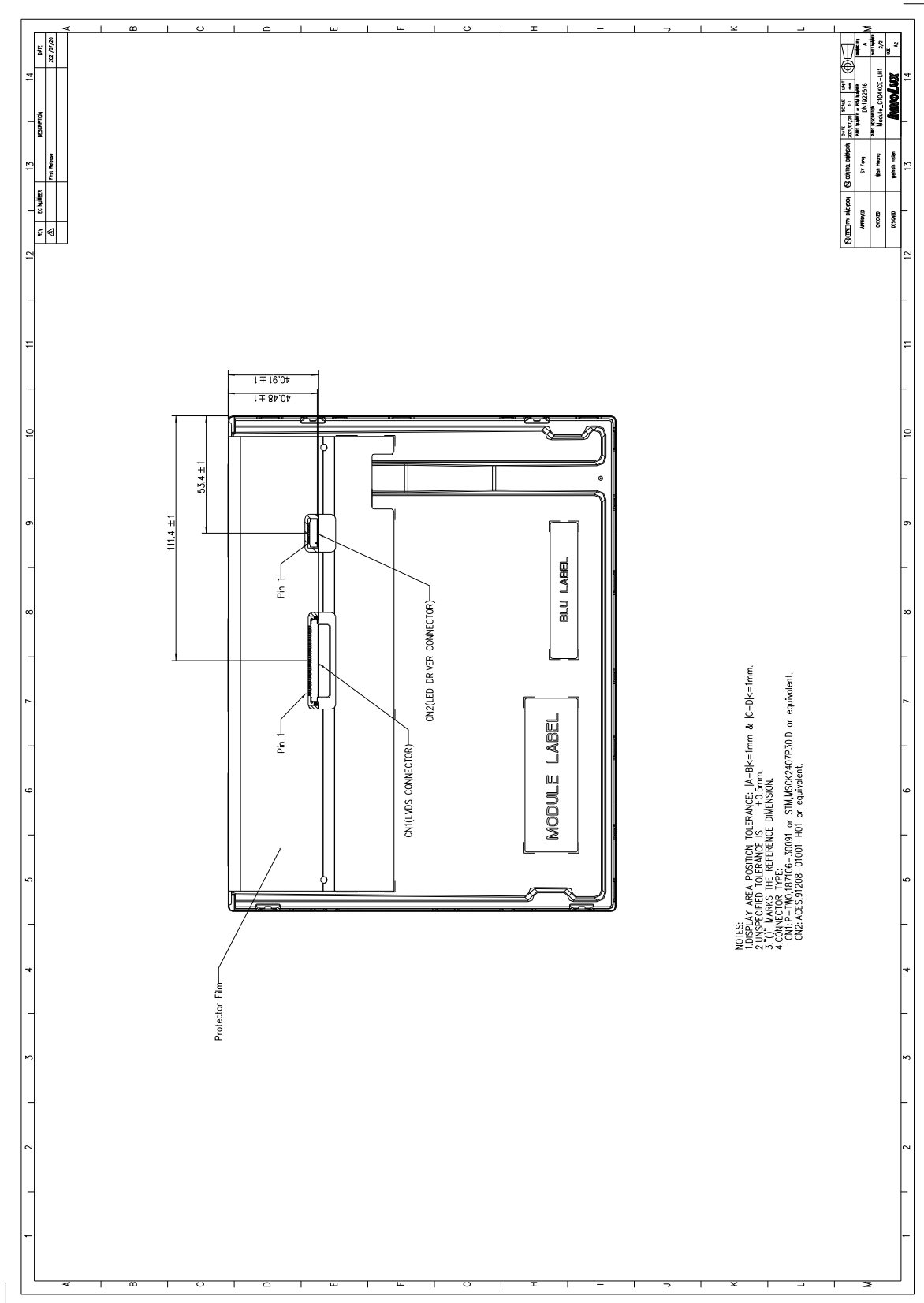



NOTES:
 1. DISPLAY AREA POSITION TOLERANCE: |A-B| ≤ 1mm & |C-D| ≤ 1mm.
 2. UNSPECIFIED TOLERANCE IS ±0.5mm.
 3. UNLESS SPECIFIED, ALL DIMENSIONS ARE IN MILLIMETERS.
 4. CONTACT FACTOR: CN1: P-TWO, 187106-30081 or STM, MS0240FP30.D or equivalent.
 CN2: ACE5, 91208-01001-H01 or equivalent.

REV	IC NUMBER	DESCRIPTION	DATE
1		Pin Release	2012/2/28

QWERTY-01000	QWERTY-01000	QWERTY-01000	QWERTY-01000
REV	REV	REV	REV
1.0	1.0	1.0	1.0
DATE	DATE	DATE	DATE
2012/2/28	2012/2/28	2012/2/28	2012/2/28
DESIGNER	DESIGNER	DESIGNER	DESIGNER
INNOVATION	INNOVATION	INNOVATION	INNOVATION
INNOVATION	INNOVATION	INNOVATION	INNOVATION
INNOVATION	INNOVATION	INNOVATION	INNOVATION
INNOVATION	INNOVATION	INNOVATION	INNOVATION

Appendix . SYSTEM COVER DESIGN NOTICE

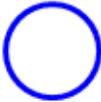
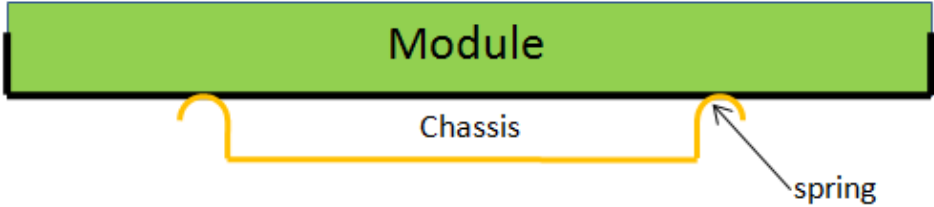
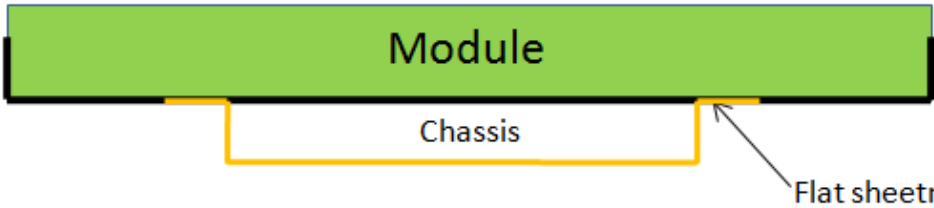
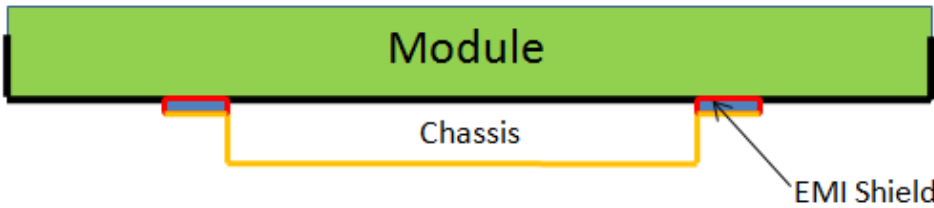
1	Set Chassis and IAVM Module touching Mode
  	 <p>Module</p> <p>Chassis</p> <p>spring</p>  <p>Module</p> <p>Chassis</p> <p>Flat sheetmetal</p>  <p>Module</p> <p>Chassis</p> <p>EMI Shielding Gasket (Tape/ Sponge)</p>
Definition	<p>a. To prevent from abnormal display & white spot after mechanical test, it is not recommended to use spring type chassis.</p> <p>b. We suggest the contact mode between Chassis and Module rear cover is Tape/Sponge, second is Flat sheet metal type chassis.</p>

2	Tape/Sponge design on system inner surface
<p>The top diagram is a cross-sectional view showing a green 'Module' resting on a yellow 'Chassis'. A red 'Tape/Sponge' layer is placed between the bottom of the module and the top of the chassis. A cyan 'System rear bezel' is shown on the right side. Below this are two top-down views of the module area. The first view, marked with a red 'X', shows four separate red L-shaped 'Tape/Sponge' pieces placed at the corners. The second view, marked with a blue circle, shows a single red rectangular 'Tape/Sponge' piece placed centrally between the module and the chassis.</p>	
Definition	<p>a. To prevent from abnormal display & white spot after mechanical test, we suggest using Tape/Sponge as medium between chassis and Module rear cover could reduce the occurrence of white spot.</p> <p>b. When using the Tape/Sponge, we suggest it be lay over between set chassis and Module rear cover. It is not recommended to add Tape/Sponge in separate location. Since each Tape/Sponge may act as pressure concentration location.</p>

3	System inner surface examination
<p>The diagram illustrates the system inner surface examination. The top portion shows a top-down view of the Module PCBA, which is a green rectangular area. A specific region within this area is highlighted with red diagonal hatching and labeled 'The hatch area'. The bottom portion shows a cross-sectional view of the Module, which is a green rectangular block. This view shows the PCBA (green) mounted on a Chassis (cyan). The System cover inner surface (cyan) is shown surrounding the PCBA. Labels indicate 'Burr' (sharp edges), 'Step' (changes in height), and 'PCBA' (the printed circuit board assembly).</p>	
Definition	<p>a. The hatch area on Module PCBA should keep at least 1mm gap(X,Y,Z direction) to any structure with system cover inner surface.</p> <p>b. Burr, Step, PCB protrusion may cause stress concentration. White spot may occur during reliability test.</p>

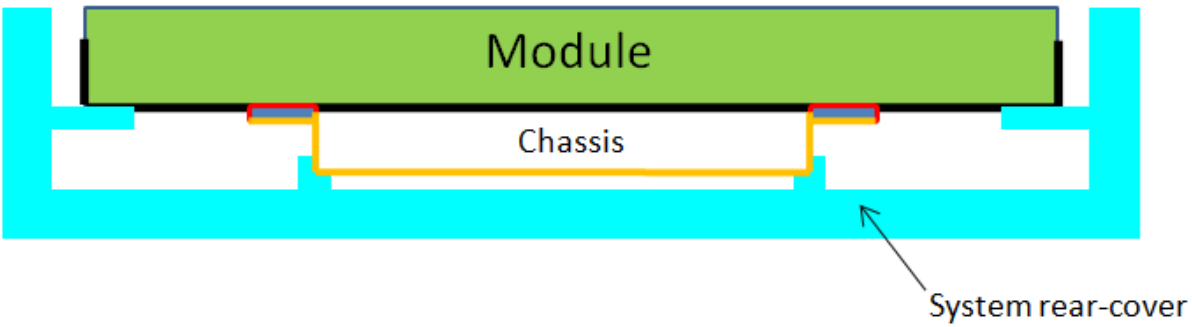
4	Material used for system rear-cover
	
Definition	<p>System rear-cover material with high rigidity is needed to resist deformation during scuffing test, hinge test, pogo test or backpack test. Abnormal display, white spot, pooling issue may occur if low rigidity material is used. Pooling issue may occur because screw's boss position for module's bracket are deformed open-close test. Solid structure design of system rear-cover may also influence the rigidity of system rear-cover. The deformation of system rear-cover should not caused interference.</p>

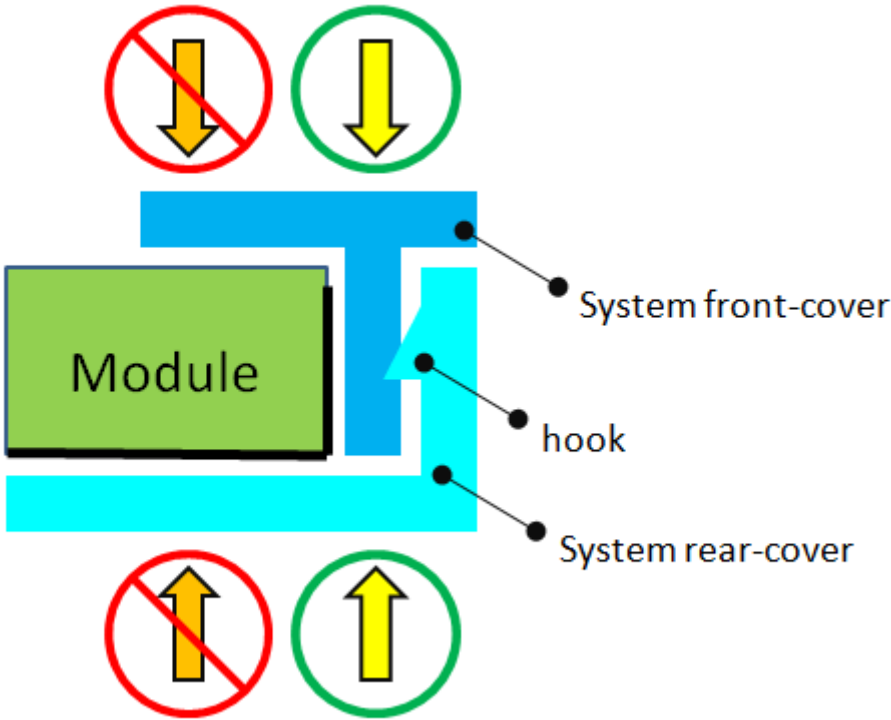
5	Assembly SOP examination for system front-cover with hook structure
	
Definition	<p>To prevent panel crack during system front-cover assembly process with hook structure, it is not recommended to press panel or any location that relate directly to the panel.</p>

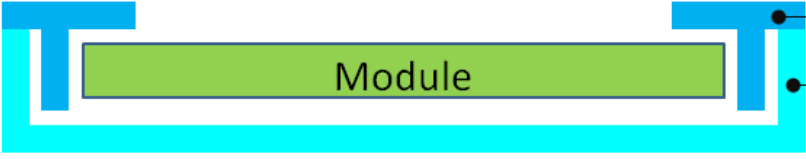
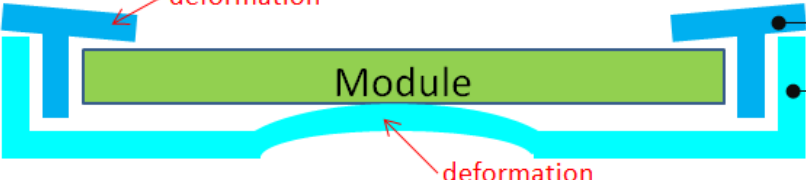
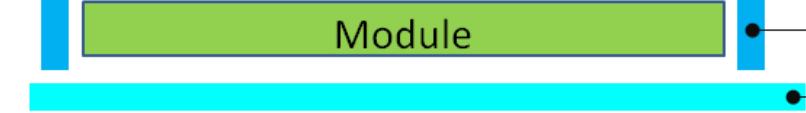
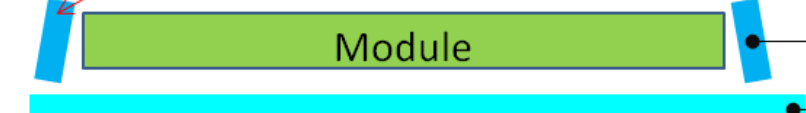
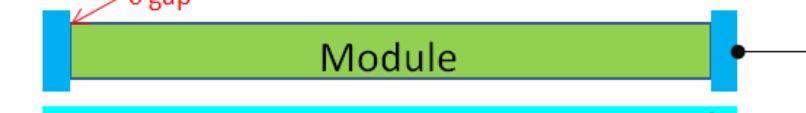
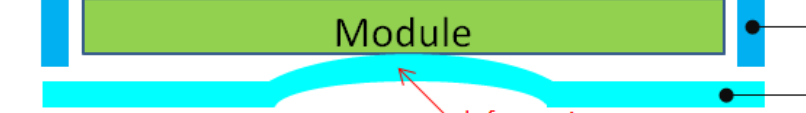
6	Permanent deformation of system cover after reliability test
○	 <ul style="list-style-type: none"> ● System front-cover ● System rear-cover
✗	 <ul style="list-style-type: none"> ● System front-cover ● System rear-cover
○	 <ul style="list-style-type: none"> ● System front-cover ● System rear-cover
✗	 <ul style="list-style-type: none"> ● System front-cover ● System rear-cover
✗	 <ul style="list-style-type: none"> ● System front-cover ● System rear-cover
✗	 <ul style="list-style-type: none"> ● System front-cover ● System rear-cover
Definition	<p>System cover including front cover and rear cover may deform during reliability test. Permanent deformation of system front cover and rear cover after reliability test should not interfere with panel. Because it may cause issue such as pooling, abnormal display, white spot and also cell creak.</p> <p>Note: If the interference cannot be avoided, please feel free to contract INX FAE Engineer for collaboration design. We can help to verify and pass risk assessment for customer reference.</p>

7	Design gap A between panel & any components on system rear-cover
Definition	<p>System cover including front cover and rear cover may deform during reliability test. Permanent deformation of system front cover and rear cover after reliability test should not interfere with panel. Because it may cause issue such as pooling, abnormal display, white spot and also cell creak.</p> <p>Note: If the interference cannot be avoided, please feel free to contract INX FAE Engineer for collaboration design. We can help to verify and pass risk assessment for customer reference.</p>

8	Design gap B between system front-cover & panel surface
Definition	<p>Gap between system front-cover & panel surface is needed to prevent pooling or glass broken. Zero gap or interference such as burr and warpage from mold frame may cause pooling issue near system front-cover opening edge. This phenomenon is obvious during swing test, hinge test, knock test or during pooling inspection procedure.</p> <p>To remain sufficient gap, design with system rib higher than maximum panel thickness is recommended.</p> <p>Note: If the interference cannot be avoided, please feel free to contract INX FAE Engineer for collaboration design. We can help to verify and pass risk assessment for customer reference.</p>

9	Design gap C between panel & system front-cover or protrusions
Definition	<p>Gap between panel & system front-cover or protrusions is needed to prevent shock test failure. Because system front-cover or protrusions with small gap may hit panel during the test. Issue such as cell crack, abnormal display may occur.</p> <p>The gap should be large enough to absorb the maximum displacement during the test.</p> <p>Note: If the interference cannot be avoided, please feel free to contract INX FAE Engineer for collaboration design. We can help to verify and pass risk assessment for customer reference.</p>

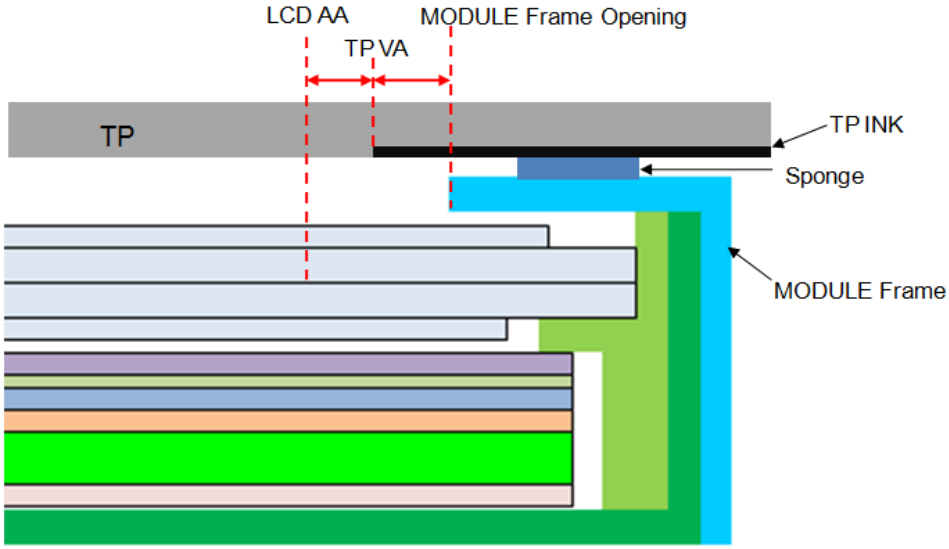
10	Design distance between TP AA to LCD AA
	
Definition	TP VA should avoid TP ink area covering LCD AA or causing the module frame to be exposed.

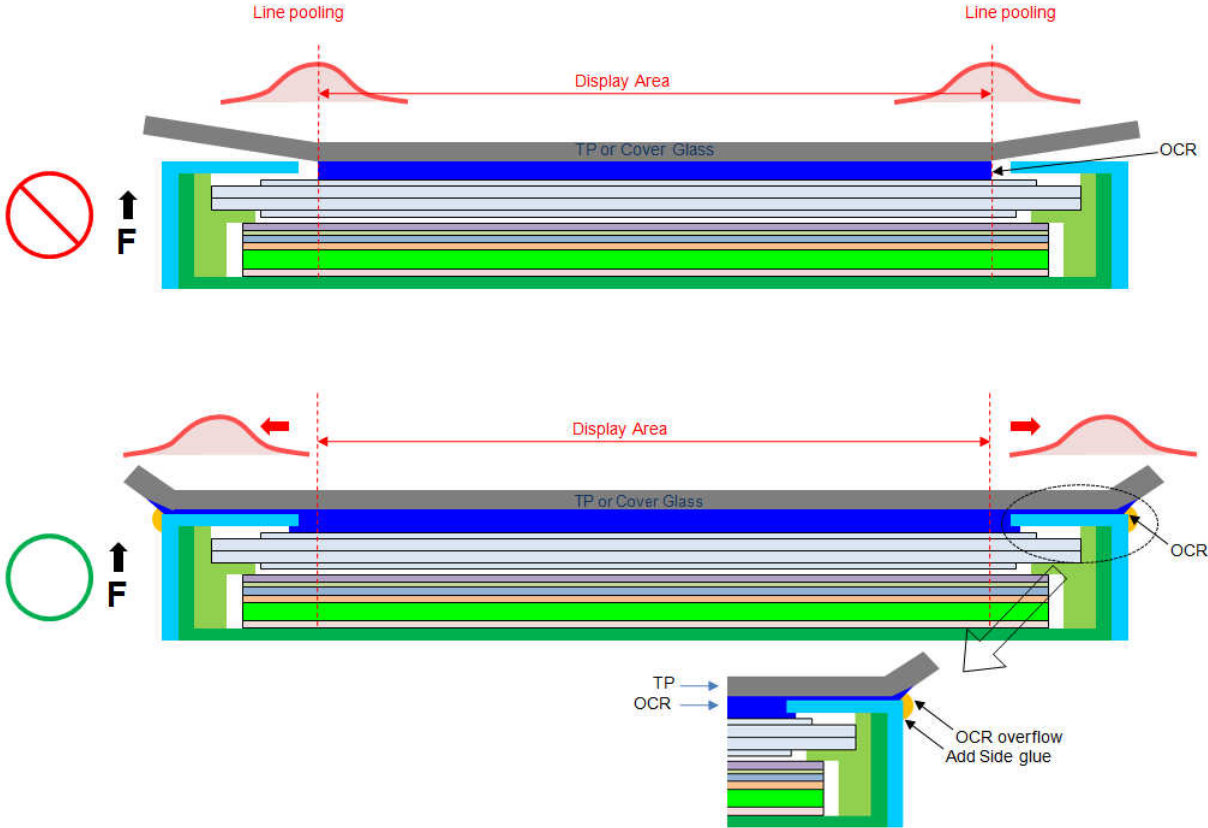
11	Use OCR Lamination
	
Definition	<ol style="list-style-type: none"> 1.OCR glue as possible beyond module, in order to avoid Line Pooling 2.Add side glue to avoid Line Pooling

DATA MODUL

Passion Displayed



All good things come in threes:

With **Hardware**, **Software** and **Services**, we realise unique display solutions that turn your ideas into reality.

www.data-modul.com

