

- Tentative Specification
- Preliminary Specification
- Approval Specification

MODEL NO.: G150XJE  
SUFFIX: E01

<b>Customer:</b>	
<b>APPROVED BY</b>	<b>SIGNATURE</b>
<b>Name / Title</b> _____	_____
Note	
_____	
Please return 1 copy for your confirmation with your signature and comments.	

Approved By	Checked By	Prepared By
陳立錚	林秋森	吳承旻

**CONTENTS**

<b>1. GENERAL DESCRIPTION .....</b>	<b>4</b>
1.1 OVERVIEW .....	4
1.2 FEATURE .....	4
1.3 APPLICATION .....	4
1.4 GENERAL SPECIFICATIONS .....	4
1.5 MECHANICAL SPECIFICATIONS .....	5
<b>2. ABSOLUTE MAXIMUM RATINGS .....</b>	<b>6</b>
2.1 ABSOLUTE RATINGS OF ENVIRONMENT .....	6
2.2 ELECTRICAL ABSOLUTE RATINGS .....	7
2.2.1 TFT LCD MODULE .....	7
2.2.2 BACKLIGHT UNIT .....	7
<b>3. ELECTRICAL CHARACTERISTICS .....</b>	<b>8</b>
3.1 TFT LCD MODULE .....	8
3.2 INPUT TERMINAL PIN ASSIGNMENT .....	9
3.3 ELECTRICAL CHARACTERISTICS .....	10
3.3.1 TFT LCD MODULE .....	10
3.3.2 BACKLIGHT UNIT .....	11
3.4 DISPLAY PORT INPUT SIGNAL TIMING SPECIFICATIONS .....	12
3.4.1 ELECTRICAL SPECIFICATIONS .....	12
3.4.2 COLOR DATA INPUT ASSIGNMENT .....	13
3.5 INTERFACE TIMING .....	14
3.6 POWER ON/OFF SEQUENCE .....	15
<b>4. OPTICAL CHARACTERISTICS .....</b>	<b>18</b>
4.1 TEST CONDITIONS .....	18
4.2 OPTICAL SPECIFICATIONS .....	18
<b>5. RELIABILITY TEST CRITERIA .....</b>	<b>21</b>
<b>6. PACKAGING .....</b>	<b>22</b>
6.1 PACKING SPECIFICATIONS .....	22
6.2 PACKING METHOD .....	22
6.3 UN-PACKING METHOD .....	23
<b>7. DEFINITION OF LABELS .....</b>	<b>24</b>
7.1 INX MODULE LABEL .....	24
<b>8. PRECAUTIONS .....</b>	<b>25</b>
8.1 ASSEMBLY AND HANDLING PRECAUTIONS .....	25
8.2 SAFETY PRECAUTIONS .....	25
<b>9. MECHANICAL CHARACTERISTICS .....</b>	<b>26</b>

**REVISION HISTORY**

Version	Date	Page	Description
Ver. 2.0	11 Jul 2018	All	Approval Specification was first issued.
Ver. 2.1	7 May 2019	4	1.3 Removed Vehicle application.
Ver. 2.1	7 May 2019	6	2.1 Modified the ratings of diagram.
Ver. 2.1	7 May 2019	11	3.3.2 Converter Power Supply Current & Backlight Power Consumption modified.
Ver. 2.1	7 May 2019	13	3.4.2 Gray Scale of Red/Green/Blue modified.

## 1. GENERAL DESCRIPTION

### 1.1 OVERVIEW

G150XJE-E01 is a 15.0" TFT Liquid Crystal Display IAV module with LED Backlight units and 30 pins eDP interface. This module supports 1024 x 768 XGA mode and can display 16.7M/262k colors.

The PSWG is to establish a set of displays with standard mechanical dimensions and select electrical interface requirements for an industry standard 15.0" XGA LCD panel and the LED driving device for Backlight is built in PCBA.

### 1.2 FEATURE

- XGA (1024 x 768 pixels) resolution
- PSWG (Panel Standardization Working Group)
- Wide operating temperature.
- RoHS compliance

### 1.3 APPLICATION

- TFT LCD Monitor
- Factory Application
- Amusement

### 1.4 GENERAL SPECIFICATIONS

Item	Specification	Unit	Note
Active Area	304.1 (H) x 228.1(V) (15.0" diagonal)	mm	(1)
Bezel Opening Area	307.4(H) x 231.3(V)	mm	
Driver Element	a-Si TFT active matrix	-	-
Pixel Number	1024 x R.G.B x 768	pixel	-
Pixel Pitch	0.297(H) x 0.297(W)	mm	-
Pixel Arrangement	RGB vertical Stripe	-	-
Display Colors	16,777,216 / 262,144	color	-
Display Mode	Normally Black	-	-
Surface Treatment	Hard Coating (3H), Anti-Glare	-	-
Module Power Consumption	9.8W	W	Max.

1.5 MECHANICAL SPECIFICATIONS

Item		Min.	Typ.	Max.	Unit	Note
Module Size	Horizontal(H)	326.0	326.5	327.0	mm	(1)
	Vertical(V)	253.0	253.5	254.0	mm	
	Depth(D)	8.6	9.1	9.6	mm	(1)(2)
Bezel Area	Horizontal	307.1	307.4	307.7	mm	-
	Vertical	231.0	231.3	231.6	mm	
Active Area	Horizontal	-	304.1	-	mm	
	Vertical	-	228.1	-	mm	
Weight		-	942	980	g	

Note (1) Please refer to the attached drawings for more information of front and back outline dimensions.

Note (2) The depth is without connector.

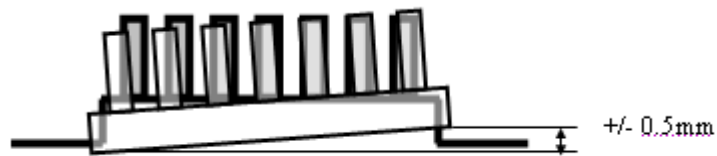

**2. ABSOLUTE MAXIMUM RATINGS**

**2.1 ABSOLUTE RATINGS OF ENVIRONMENT**

Item	Symbol	Value		Unit	Note
		Min.	Max.		
Operating Ambient Temperature	TOP	-20	+70	°C	(1)(2)(3)
Storage Temperature	TST	-30	+70	°C	(1)(2)(3)

Note (1) Temperature and relative humidity range is shown in the figure below.

Note (2) 90 %RH Max. (Ta < 40°C).

Note (3) Wet-bulb temperature should be 39°C Max.

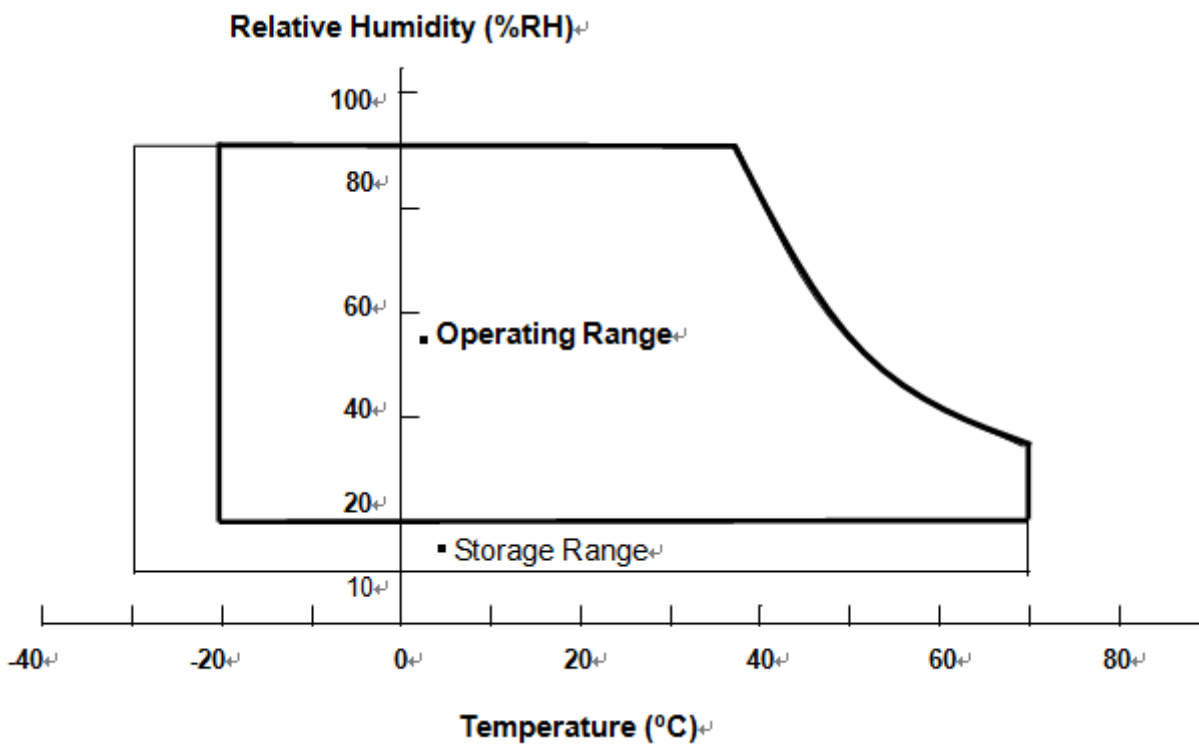

## 2.2 ELECTRICAL ABSOLUTE RATINGS

### 2.2.1 TFT LCD MODULE

Item	Symbol	Value		Unit	Note
		Min.	Max.		
Power Supply Voltage	VCC	-0.3	4	V	(1)

### 2.2.2 BACKLIGHT UNIT

Item	Symbol	Value		Unit	Note
		Min.	Max.		
Converter Voltage	$V_i$	-0.3	18	V	(1), (2)
Enable Voltage	EN	---	5.5	V	
Backlight Adjust	Dimming	---	5.5	V	

Note (1) Permanent damage to the device may occur if maximum values are exceeded. Function operation should be restricted to the conditions described under Normal Operating Conditions.

Note (2) Specified values are for lamp (Refer to 3.3.2 for further information).

3. ELECTRICAL CHARACTERISTICS

3.1 TFT LCD MODULE

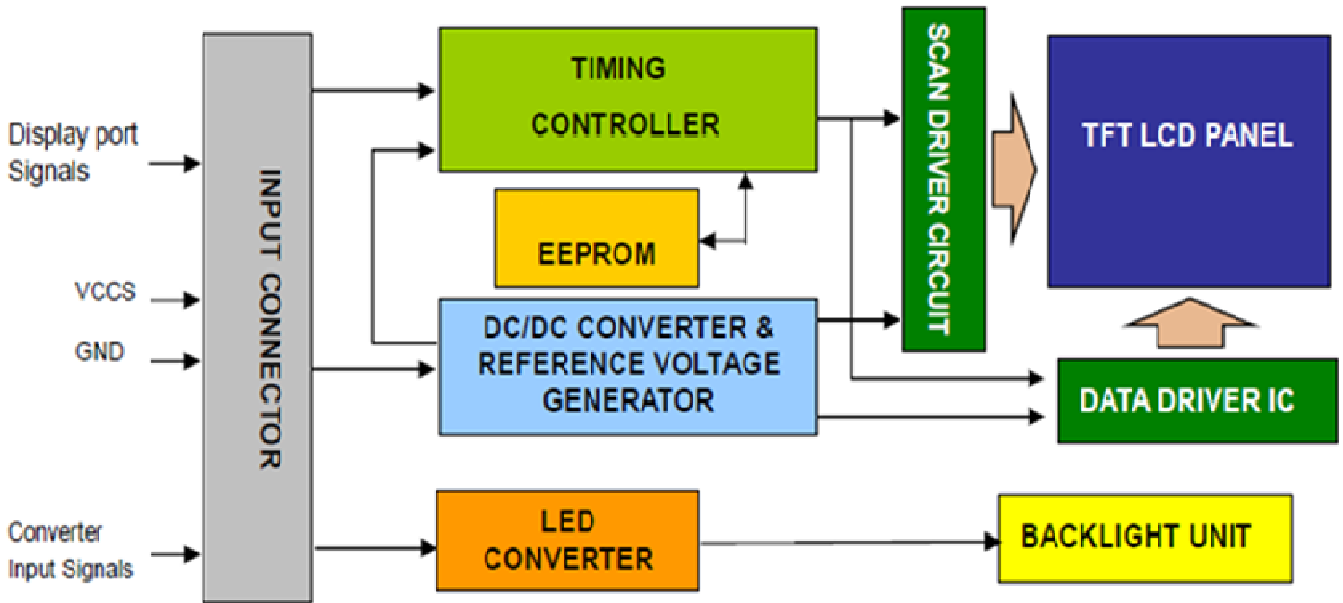



**3.2 INPUT TERMINAL PIN ASSIGNMENT**

PIN ASSIGNMENT

Pin No.	Symbol	Function	Polarity	Note
1	NC	No Connection(Reserved LCD test)		
2	H_GND	High Speed Ground		
3	NC	No Connection(Reserved LCD test)		
4	NC	No Connection(Reserved LCD test)		
5	H_GND	High Speed Ground		
6	ML0-	Complement Signal-Lane 0		
7	ML0+	True Signal-Main-Lane 0		
8	H_GND	High Speed Ground		
9	AUX+	True Signal-Auxiliary Channel		
10	AUX-	Complement Signal- Auxiliary Channel		
11	H_GND	High Speed Ground		
12	VCCS	Power Supply +3.3V (typical)		
13	VCCS	Power Supply +3.3V (typical)		
14	NC	No Connection(Reserved LCD test)		
15	GND	Ground		
16	GND	Ground		
17	HPD	Hot Plug Detect		
18	BL_GND	BL Ground		
19	BL_GND	BL Ground		
20	BL_GND	BL Ground		
21	BL_GND	BL Ground		
22	LED_EN	BL_Enable Signal of LED Converter		
23	LED_PWM	PWM Dimming Control Signal of LED Converter		
24	NC	No Connection(Reserved LCD test)		
25	NC	No Connection(Reserved LCD test)		
26	LED_VCCS	BL Power +12.0V (typical)		
27	LED_VCCS	BL Power +12.0V (typical)		
28	LED_VCCS	BL Power +12.0V (typical)		
29	LED_VCCS	BL Power +12.0V (typical)		
30	NC	No Connection(Reserved LCD test)		

Note (1) Connector Part No.: I-PEX 20455-030E-76 or equivalent.

Note (2)User's connector Part No.: I-PEX 20453-030T-03 or equivalent.

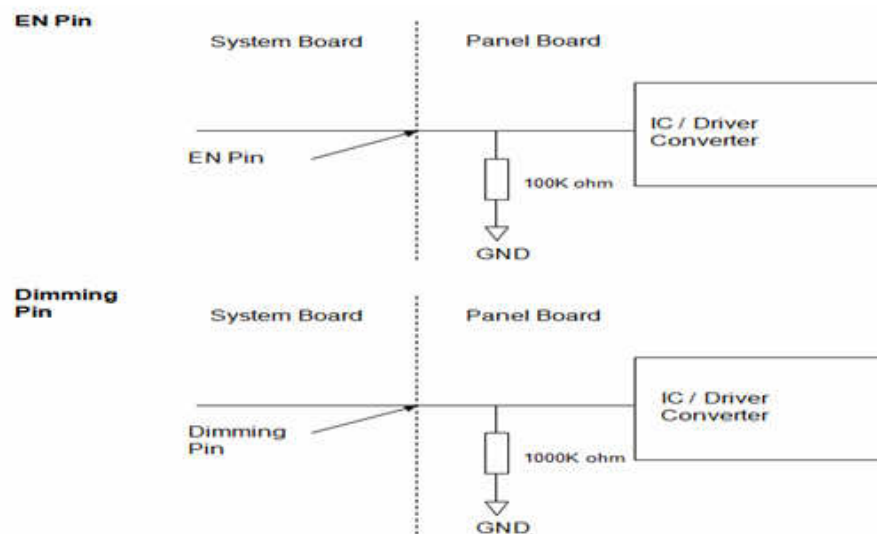

3.3 ELECTRICAL CHARACTERISTICS

3.3.1 TFT LCD MODULE

Parameter	Symbol	Value			Unit	Note	
		Min.	Typ.	Max.			
Power Supply Voltage	$V_{CC}$	3.0	3.3	3.6	V	-	
Ripple Voltage	$V_{RP}$	-	50	-	mVp-p		
Rush Current	$I_{RUSH}$	-	-	2.0	A	(2)	
Power Supply Current	White	-	440	535	mA	(3)a	
	Black	-	340	410	mA	(3)b	
HPD Impedance	$V_{HPD}$	30K			ohm		
HPD	High Level	$V_{IH}$	2.25	-	2.75	V	-
	Low Level	$V_{IL}$	0	-	0.4	V	-

Note (1) The module should be always operated within above ranges.

Note (2) Measurement Conditions:

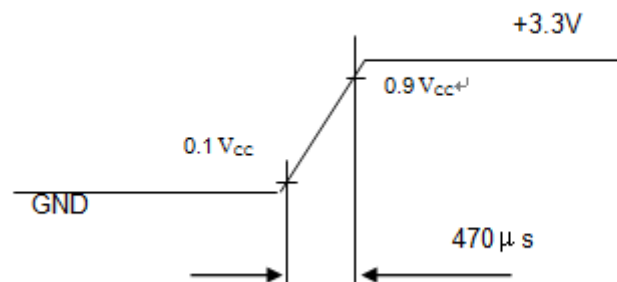
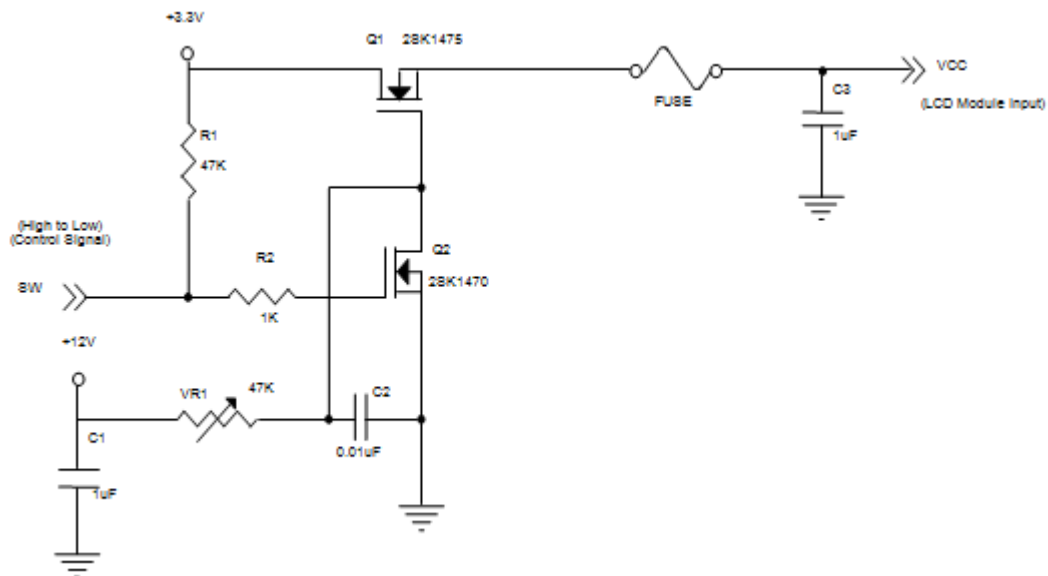

Note (3) The specified power supply current is under the conditions at  $V_{DD} = 3.3V$ ,  $T_a = 25 \pm 2^\circ C$ , DC Current and  $f_v = 60\text{ Hz}$ , whereas a power dissipation check pattern below is displayed.

a. White Pattern

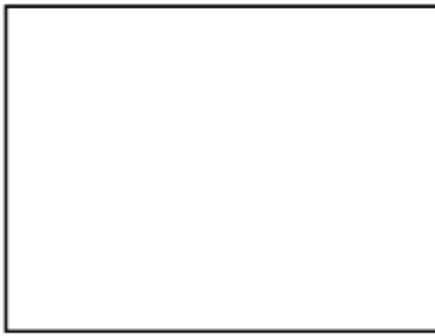

Active Area

b. Black Pattern



Active Area

### 3.3.2 BACKLIGHT UNIT

Ta = 25 ± 2 °C

Parameter	Symbol	Value			Unit	Note	
		Min.	Typ.	Max.			
Converter Power Supply Voltage	V <sub>i</sub>	10.8	12.0	13.2	V		
Converter Power Supply Current	I <sub>i</sub>	0.48	0.68	0.88	A	@ Vi = 12V (Duty 100%)	
Rush Current	I <sub>RUSH</sub>			5	A	(4)	
Backlight Power Consumption	P <sub>BL</sub>	-	--	8.2	W	@ Vi = 12V (Duty 100%)	
EN Control Level	Backlight on	-	2.0	3.3	5.0	V	
	Backlight off	-	0	---	0.15	V	
PWM Control Level	PWM High Level	-	2.0	3.3	5.0	V	
	PWM Low Level	-	0	-	0.15	V	
PWM Control Duty Ratio	-	1	-	100	%	@200Hz	
PWM Control Frequency	f <sub>PWM</sub>	190	200	20k	Hz	(2)	
LED Life Time	L <sub>L</sub>	50,000	70,000	-	Hrs	(3)	

Note (1) LED current is measured by utilizing a high frequency current meter as shown below:

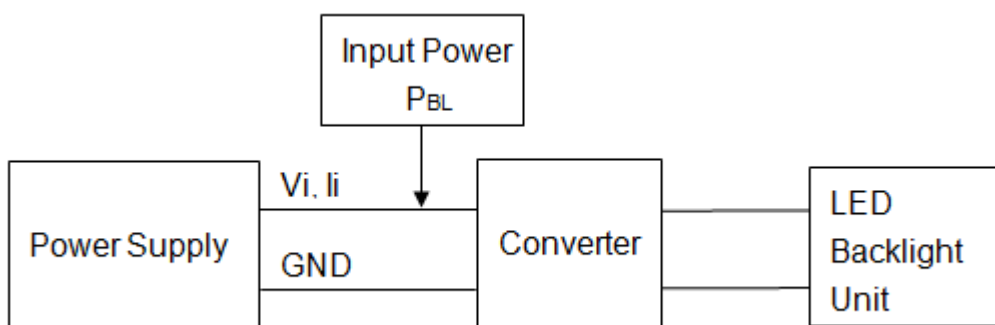

Note (2) At 20k Hz PWM control frequency, duty ratio range is restricted from 20% to 100%.

Note (3) The lifetime of LED is estimated data and defined as the time when it continues to operate under the conditions at Ta = 25 ± 2 °C and Duty 100% until the brightness becomes ≤ 50% of its original value. Operating LED under high temperature environment will reduce life time and lead to color shift.

3.4 DISPLAY PORT INPUT SIGNAL TIMING SPECIFICATIONS

3.4.1 ELECTRICAL SPECIFICATIONS

Parameter	Symbol	Min.	Typ.	Max.	Unit	Notes
Differential Signal Common Mode Voltage(MainLink and AUX)	VCM	0		2	V	(1)(4)
AUX AC Coupling Capacitor	C_Aux_Source	75		200	nF	(2)
Main Link AC Coupling Capacitor	C_ML_Source	75		200	nF	(3)

Note (1) Display port interface related AC coupled signals should follow VESA DisplayPort Standard Version 1. Revision 1a and VESA Embedded DisplayPort™ Standard Version 1.2. There are many optional items described in eDP1.2. If some optional item is requested, please contact us.

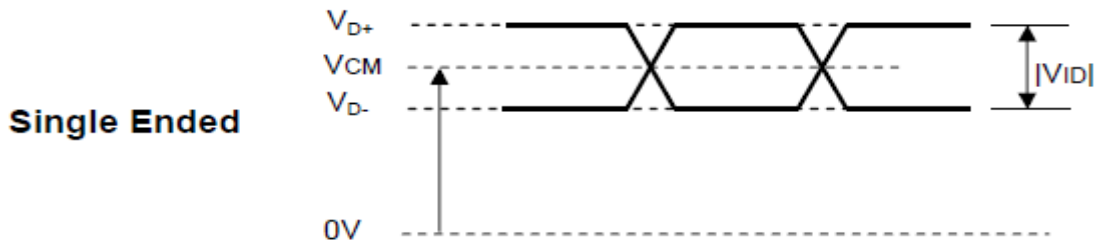

Note (2) Recommended eDP AUX Channel topology is as below and the AUX AC Coupling Capacitor (C\_Aux\_Source) should be placed on the source device.

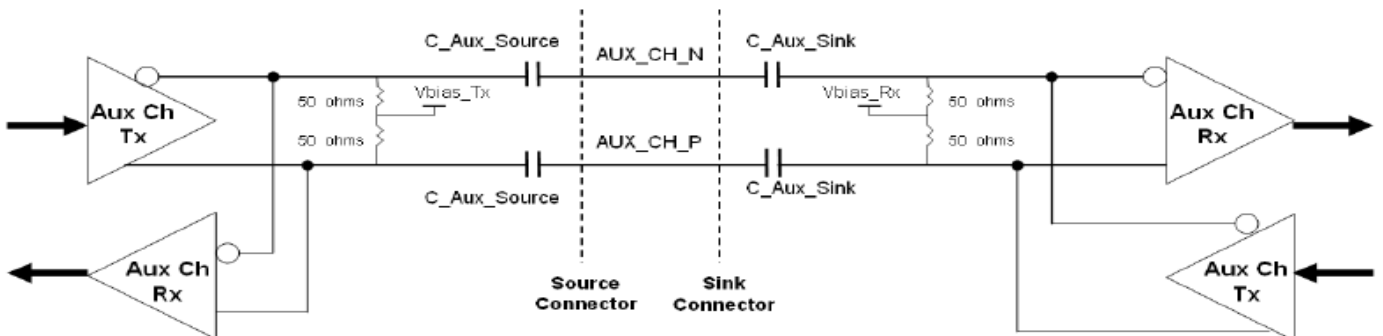

Note (3) Recommended Main Link Channel topology is as below and the Main Link AC Coupling Capacitor (C\_ML\_Source) should be placed on the source device.

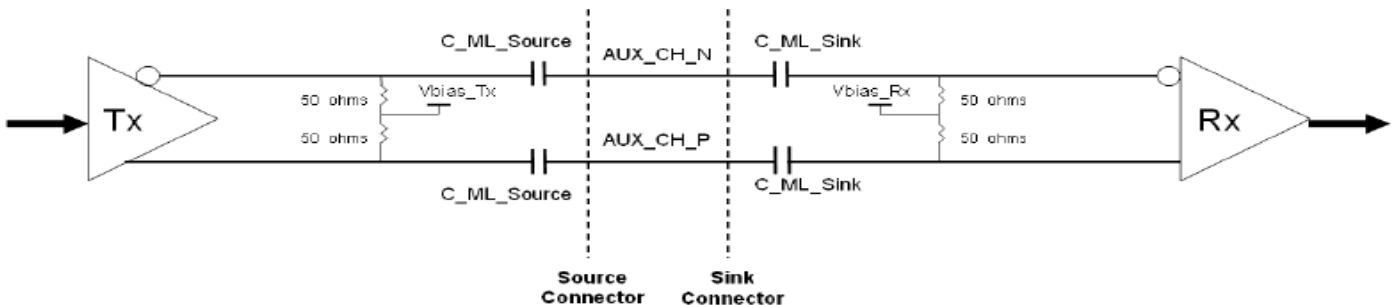

Note (4) The source device should pass the test criteria described in DisplayPortCompliance Test Specification(CTS) 1.1

**3.4.2 COLOR DATA INPUT ASSIGNMENT**

The brightness of each primary color (red, green and blue) is based on the 8-bit gray scale data input for the color.

The higher the binary input the brighter the color. The table below provides the assignment of color versus data input.

Color		Data Signal																							
		Red								Green								Blue							
		R7	R6	R5	R4	R3	R2	R1	R0	G7	G6	G5	G4	G3	G2	G1	G0	B7	B6	B5	B4	B3	B2	B1	B0
Basic Colors	Black	0	0	0	0	0	0	0	0	0	0	0	0	0	0	0	0	0	0	0	0	0	0	0	0
	Red	1	1	1	1	1	1	1	1	0	0	0	0	0	0	0	0	0	0	0	0	0	0	0	0
	Green	0	0	0	0	0	0	0	0	1	1	1	1	1	1	1	1	0	0	0	0	0	0	0	0
	Blue	0	0	0	0	0	0	0	0	0	0	0	0	0	0	0	0	1	1	1	1	1	1	1	1
	Cyan	0	0	0	0	0	0	0	0	1	1	1	1	1	1	1	1	1	1	1	1	1	1	1	1
	Magenta	1	1	1	1	1	1	1	1	0	0	0	0	0	0	0	0	1	1	1	1	1	1	1	1
	Yellow	1	1	1	1	1	1	1	1	1	1	1	1	1	1	1	1	0	0	0	0	0	0	0	0
	White	1	1	1	1	1	1	1	1	1	1	1	1	1	1	1	1	1	1	1	1	1	1	1	1
Gray Scale Of Red	Red(0) / Dark	0	0	0	0	0	0	0	0	0	0	0	0	0	0	0	0	0	0	0	0	0	0	0	
	Red(1)	0	0	0	0	0	0	0	1	0	0	0	0	0	0	0	0	0	0	0	0	0	0	0	
	Red(2)	0	0	0	0	0	0	1	0	0	0	0	0	0	0	0	0	0	0	0	0	0	0	0	
	⋮	⋮	⋮	⋮	⋮	⋮	⋮	⋮	⋮	⋮	⋮	⋮	⋮	⋮	⋮	⋮	⋮	⋮	⋮	⋮	⋮	⋮	⋮	⋮	
	⋮	⋮	⋮	⋮	⋮	⋮	⋮	⋮	⋮	⋮	⋮	⋮	⋮	⋮	⋮	⋮	⋮	⋮	⋮	⋮	⋮	⋮	⋮	⋮	
	Red(253)	1	1	1	1	1	1	0	1	0	0	0	0	0	0	0	0	0	0	0	0	0	0	0	
	Red(254)	1	1	1	1	1	1	1	0	0	0	0	0	0	0	0	0	0	0	0	0	0	0	0	
	Red(255)	1	1	1	1	1	1	1	1	0	0	0	0	0	0	0	0	0	0	0	0	0	0	0	
Gray Scale Of Green	Green(0)/Dark	0	0	0	0	0	0	0	0	0	0	0	0	0	0	0	0	0	0	0	0	0	0	0	
	Green(1)	0	0	0	0	0	0	0	0	0	0	0	0	0	0	0	1	0	0	0	0	0	0	0	
	Green(2)	0	0	0	0	0	0	0	0	0	0	0	0	0	0	1	0	0	0	0	0	0	0	0	
	⋮	⋮	⋮	⋮	⋮	⋮	⋮	⋮	⋮	⋮	⋮	⋮	⋮	⋮	⋮	⋮	⋮	⋮	⋮	⋮	⋮	⋮	⋮		
	⋮	⋮	⋮	⋮	⋮	⋮	⋮	⋮	⋮	⋮	⋮	⋮	⋮	⋮	⋮	⋮	⋮	⋮	⋮	⋮	⋮	⋮	⋮	⋮	
	Green(253)	0	0	0	0	0	0	0	0	1	1	1	1	1	1	0	1	0	0	0	0	0	0	0	
	Green(254)	0	0	0	0	0	0	0	0	1	1	1	1	1	1	1	0	0	0	0	0	0	0	0	
	Green(255)	0	0	0	0	0	0	0	0	1	1	1	1	1	1	1	1	0	0	0	0	0	0	0	
Gray Scale Of Blue	Blue(0) / Dark	0	0	0	0	0	0	0	0	0	0	0	0	0	0	0	0	0	0	0	0	0	0	0	
	Blue(1)	0	0	0	0	0	0	0	0	0	0	0	0	0	0	0	0	0	0	0	0	0	0	1	
	Blue(2)	0	0	0	0	0	0	0	0	0	0	0	0	0	0	0	0	0	0	0	0	0	0	1	
	⋮	⋮	⋮	⋮	⋮	⋮	⋮	⋮	⋮	⋮	⋮	⋮	⋮	⋮	⋮	⋮	⋮	⋮	⋮	⋮	⋮	⋮	⋮		
	⋮	⋮	⋮	⋮	⋮	⋮	⋮	⋮	⋮	⋮	⋮	⋮	⋮	⋮	⋮	⋮	⋮	⋮	⋮	⋮	⋮	⋮	⋮		
	Blue(253)	0	0	0	0	0	0	0	0	0	0	0	0	0	0	0	1	1	1	1	1	1	1	0	
	Blue(254)	0	0	0	0	0	0	0	0	0	0	0	0	0	0	0	1	1	1	1	1	1	1	0	
Blue(255)	0	0	0	0	0	0	0	0	0	0	0	0	0	0	0	1	1	1	1	1	1	1	1		

Note (1)0: Low Level Voltage, 1: High Level Voltage

**3.5 INTERFACE TIMING**

**INPUT SIGNAL TIMING SPECIFICATIONS**

The input signal timing specifications are shown as the following table and timing diagram.

Signal	Item	Symbol	Min.	Typ.	Max.	Unit	Note
Frame rate	Frequency	Fr	-	60	-	Hz	-
DCLK	Clock frequency	Fc	50	65	81	MHz	-
Vertical Display Term	Total	Tv	783	806	968	Th	-
	Active Display	Tvd	-	768	-	Th	-
	Blank	Tvb	Tv-Tvd	38	Tv-Tvd	Th	-
Horizontal Display Term	Total	Th	1244	1344	2024	Tc	Th=Thd+Thb
	Active Display	Thd	-	1024	-	Tc	-
	Blank	Thb	Th-Thd	320	Th-Thd	Tc	-

Note (1) Because this module is operated by DE only mode, Hsync and Vsync input signals should be set to low logic level or ground. Otherwise, this module would operate abnormally.

Note (2) The Tv(Tvd+Tvb) must be integer, otherwise, the module would operate abnormally.

Note (3) The maximum clock frequency =  $Tv * Th * 60 < 81$  MHz.

**INPUT SIGNAL TIMING DIAGRAM**

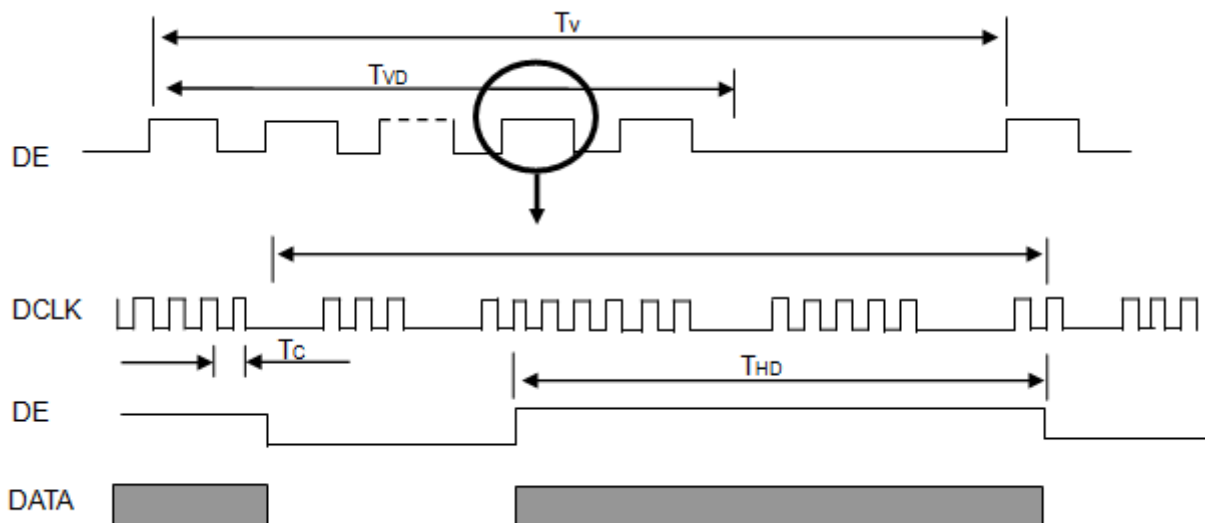

**3.6 POWER ON/OFF SEQUENCE**

To prevent a latch-up or DC operation of LCD assembly, the power on/off sequence should be as the diagram below.

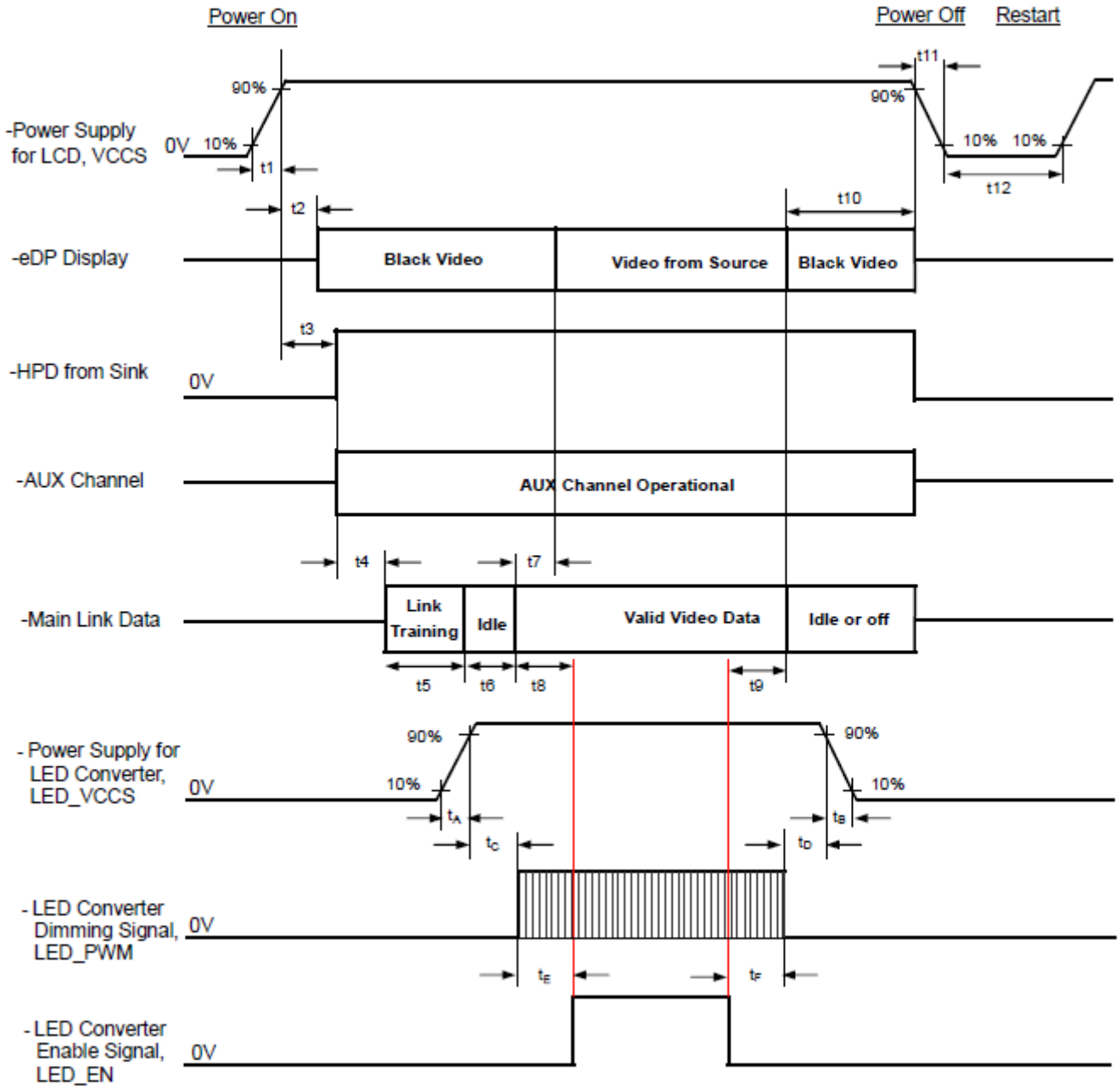

Timing Specification

Parameter	Description	Reqd. By	Value		Unit	Notes
			Min	Max		
t1	Power rail rise time, 10% to 90%	Source	0.5	10	ms	-
t2	Delay from LCD,VCCS to black video generation	Sink	0	200	ms	Automatic Black Video generation prevents display noise until valid video data is received from the Source (see Notes:2 and 3 below)
t3	Delay from LCD,VCCS to HPD high	Sink	0	200	ms	Sink AUX Channel must be operational upon HPD high (see Note:4 below )
t4	Delay from HPD high to link training initialization	Source	0	-	ms	Allows for Source to read Link capability and initialize
t5	Link training duration	Source	0	-	ms	Dependant on Source link training protocol
t6	Link idle	Source	0	-	ms	Min Accounts for required BS-Idle pattern. Max allows for Source frame synchronization
t7	Delay from valid video data from Source to video on display	Sink	0	50	ms	Max value allows for Sink to validate video data and timing. At the end of T7, Sink will indicate the detection of valid video data by setting the SINK_STATUS bit to logic 1 (DPCD 00205h, bit 0), and Sink will no longer generate automatic Black Video
t8	Delay from valid video data from Source to backlight on	Source	80	-	ms	Source must assure display video is stable *: Recommended by INX. To avoid garbage image.
t9	Delay from backlight off to end of valid video data	Source	50	-	ms	Source must assure backlight is no longer illuminated. At the end of T9, Sink will indicate the detection of no valid video data by setting the SINK_STATUS bit to logic 0 (DPCD 00205h, bit 0), and Sink will automatically display Black Video. (See Notes: 2 and 3 below) *: Recommended by INX. To avoid garbage image.
t10	Delay from end of valid video data from Source to power off	Source	0	500	ms	Black video will be displayed after receiving idle or off signals from Source
t11	VCCS power rail fall time, 90% to 10%	Source	0.5	10	ms	-



t12	VCCS Power off time	Source	500	-	ms	-
t <sub>A</sub>	LED power rail rise time, 10% to 90%	Source	0.5	10	ms	-
t <sub>B</sub>	LED power rail fall time, 90% to 10%	Source	0	10	ms	-
t <sub>C</sub>	Delay from LED power rising to LED dimming signal	Source	1	-	ms	-
t <sub>D</sub>	Delay from LED dimming signal to LED power falling	Source	1	-	ms	-
t <sub>E</sub>	Delay from LED dimming signal to LED enable signal	Source	(0)	-	ms	-
t <sub>F</sub>	Delay from LED enable signal to LED dimming signal	Source	(0)	-	ms	-

Note (1) Please don't plug or unplug the interface cable when system is turned on. Before LCD\_VCCS and LED\_VCCS are ready, it is recommended to pull down the backlight control signals

Note (2) The Sink must include the ability to automatically generate Black Video autonomously. The Sink must automatically enable Black Video under the following conditions:

- Upon LCDVCC power-on (within T2 max)
- When the "NoVideoStream\_Flag" (VB-ID Bit 3) is received from the Source (at the end of T9)

Note (3) The Sink may implement the ability to disable the automatic Black Video function, as described in Note (2), above, for system development and debugging purposes.

Note (4) The Sink must support AUX Channel polling by the Source immediately following LCDVCC power-on without causing damage to the Sink device (the Source can re-try if the Sink is not ready). The Sink must be able to response to an AUX Channel transaction with the time specified within T3 max.

## 4. OPTICAL CHARACTERISTICS

### 4.1 TEST CONDITIONS

Item	Value	Unit
Ambient Temperature (Ta)	25±2	°C
Ambient Humidity (Ha)	50±10	%RH
Supply Voltage	According to typical value in "ELECTRICAL CHARACTERISTICS"	
Input Signal		
LED Light Bar Input Current Per Input Pin		

### 4.2 OPTICAL SPECIFICATIONS

The relative measurement methods of optical characteristics are shown in 4.2 and all items are measured at the center point of screen except white variation. The following items should be measured under the test conditions described in 4.1 and stable environment shown in Note (5).

Item	Symbol	Condition	Min.	Typ.	Max.	Unit	Note
Color Chromaticity	Red	R <sub>x</sub>	0.597	0.647	0.697	-	(1), (5)
		R <sub>y</sub>	0.288	0.338	0.388		
	Green	G <sub>x</sub>	0.271	0.321	0.371		
		G <sub>y</sub>	0.556	0.606	0.656		
	Blue	B <sub>x</sub>	0.107	0.157	0.207		
		B <sub>y</sub>	0.000	0.039	0.089		
	White	W <sub>x</sub>	0.263	0.313	0.363		
		W <sub>y</sub>	0.279	0.329	0.379		
Center Luminance of White	L <sub>C</sub>		320	400			(4), (5)
Contrast Ratio	CR		1800	2500			(2), (5)
Response Time	T <sub>R</sub>	θ <sub>x</sub> =0°, θ <sub>y</sub> =0°	-	16	21	-	(3)
	T <sub>F</sub>		-	7	14	-	
White Variation	δW	θ <sub>x</sub> =0°, θ <sub>y</sub> =0° USB2000	-	1.25	1.33		(5), (6)
Viewing Angle	Horizontal	θ <sub>x+</sub>	80	88	-	Deg.	(1), (5)
		θ <sub>x-</sub>	80	88	-		
	Vertical	θ <sub>y+</sub>	80	88	-		
		θ <sub>y-</sub>	80	88	-		

Note (1) Definition of Viewing Angle ( $\theta_x, \theta_y$ ):

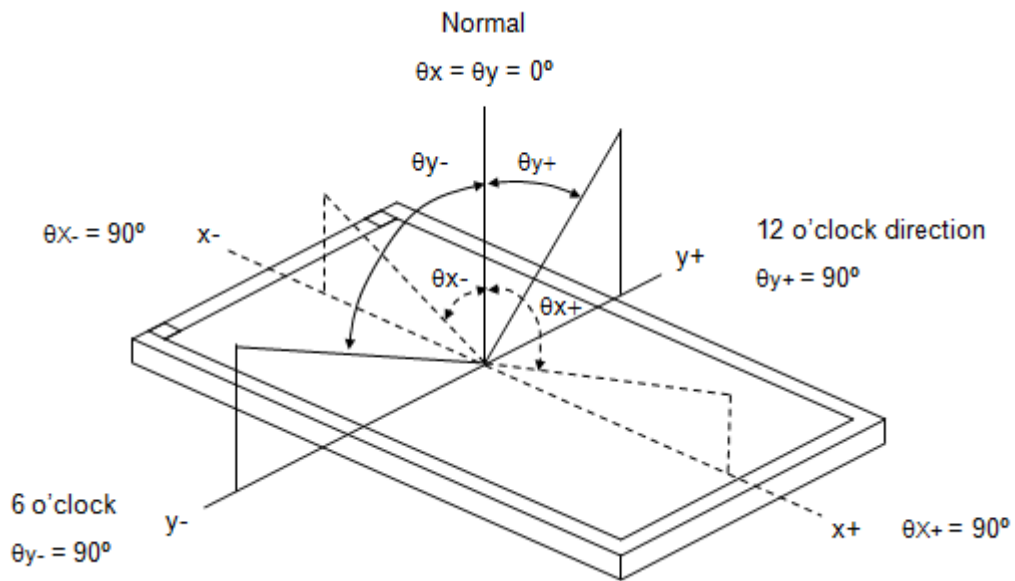

Note (2) Definition of Contrast Ratio (CR):

The contrast ratio can be calculated by the following expression.

$$\text{Contrast Ratio (CR)} = L_{255} / L_0$$

L255: Luminance of gray level 255

L0: Luminance of gray level 0

$$\text{CR} = \text{CR} (5)$$

CR (X) is corresponding to the Contrast Ratio of the point X at Figure in Note (6).

Note (3) Definition of Response Time ( $T_R, T_F$ ):

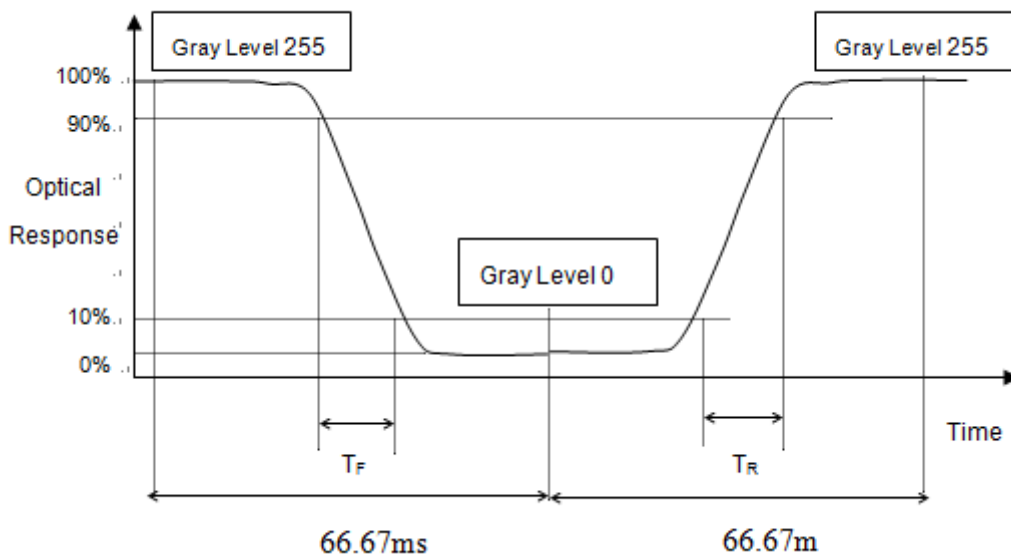

Note (4) Definition of Luminance of White ( $L_C$ ):

Measure the luminance of gray level 255 at center point

$$L_C = L (5)$$

L (x) is corresponding to the luminance of the point X at Figure in Note (6).

**Note (5) Measurement Setup:**

The LCD module should be stabilized at given temperature for 20 minutes to avoid abrupt temperature change during measuring. In order to stabilize the luminance, the measurement should be executed after lighting Backlight for 20 minutes in a windless room.

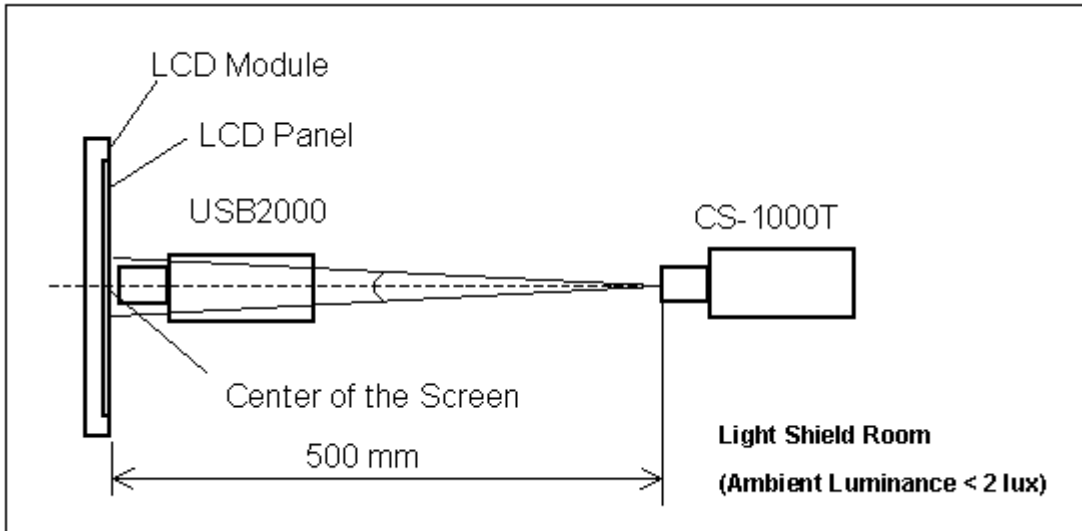

**Note (6) Definition of White Variation ( $\delta W$ ):**

Measure the luminance of gray level 63 (255) at 9 points

$$\delta W = \frac{\text{Maximum [L (1), L (2), L (3), L (4), L (5), L (6), L (7), L (8), L (9)]}}{\text{Minimum [L (1), L (2), L (3), L (4), L (5), L (6), L (7), L (8), L (9)]}}$$

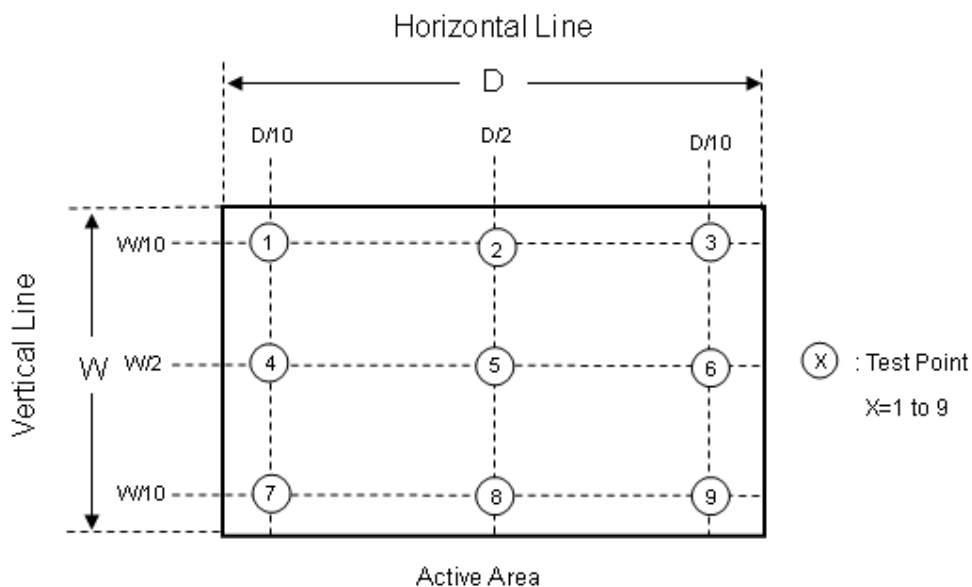

## 5. RELIABILITY TEST CRITERIA

Test Item	Test Condition	Note
High Temperature Storage Test	70°C, 240 hours	(1),(2) (4),(5)
Low Temperature Storage Test	-30°C, 240 hours	
Thermal Shock Storage Test	-30°C, 0.5 hour ↔ 70°C, 0.5 hour; 100cycles, 1 hour/cycle)	
High Temperature Operation Test	70°C, 240 hours	
Low Temperature Operation Test	-20°C, 240 hours	
High Temperature & High Humidity Operation Test	60°C, RH 90%, 240 hours	(1),(2) (4),(6)
ESD Test (Operation)	150pF, 330Ω, 1 sec/cycle Condition 1 : panel contact, ±8 KV Condition 2 : panel non-contact ±15 KV	(1), (4)
Shock (Non-Operating)	50G, 11ms, half sine wave, 1 time for ± X, ± Y, ± Z direction	(2), (3)
Vibration (Non-Operating)	1.5G, 10 ~ 300 Hz sine wave, 10 min/cycle, 3 cycles each X, Y, Z direction	(2), (3)

Note (1) There should be no condensation on the surface of panel during test.

Note (2) Temperature of panel display surface area should be 70°C Max.

Note (3) At testing Vibration and Shock, the fixture in holding the module has to be hard and rigid enough so that the module would not be twisted or bent by the fixture.

Note (4) In the standard conditions, there is no function failure issue occurred. All the cosmetic specification is judged before reliability test.

Note (5) Before cosmetic and function test, the product must have enough recovery time, at least 2 hours at room temperature.

Note (6) Before cosmetic and function test, the product must have enough recovery time, at least 24 hours at room temperature.

## 6. PACKAGING

### 6.1 PACKING SPECIFICATIONS

- (1) 16pcs LCD modules / 1 Box
- (2) Box dimensions: 511 (L) X 420 (W) X 360 (H) mm
- (3) Weight: approximately 16.7Kg (16 modules per box)

### 6.2 PACKING METHOD

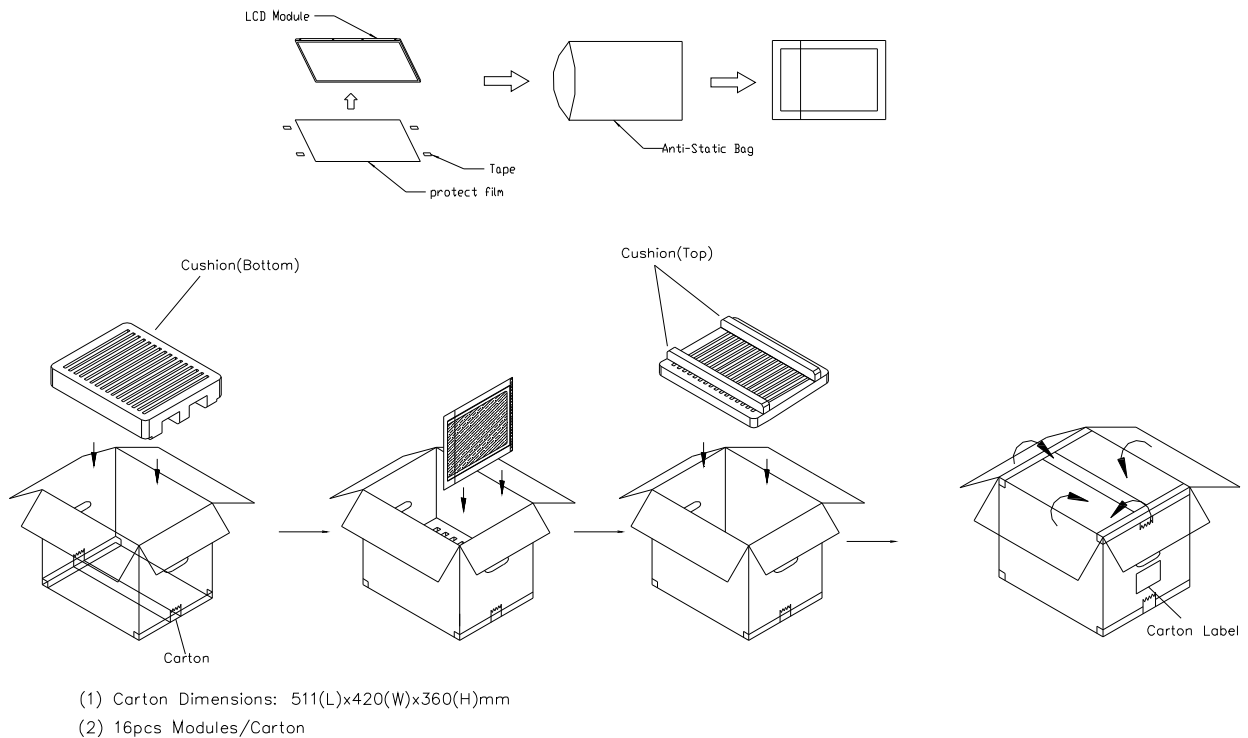

Figure. 6-1 Packing method

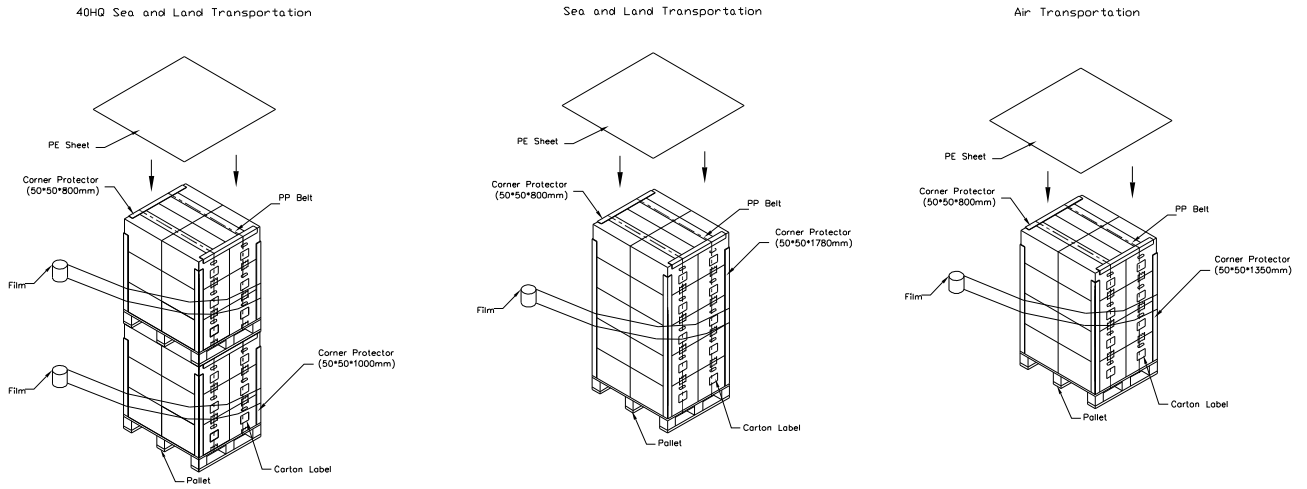

Figure. 6-2 Packing method

**6.3 UN-PACKING METHOD**

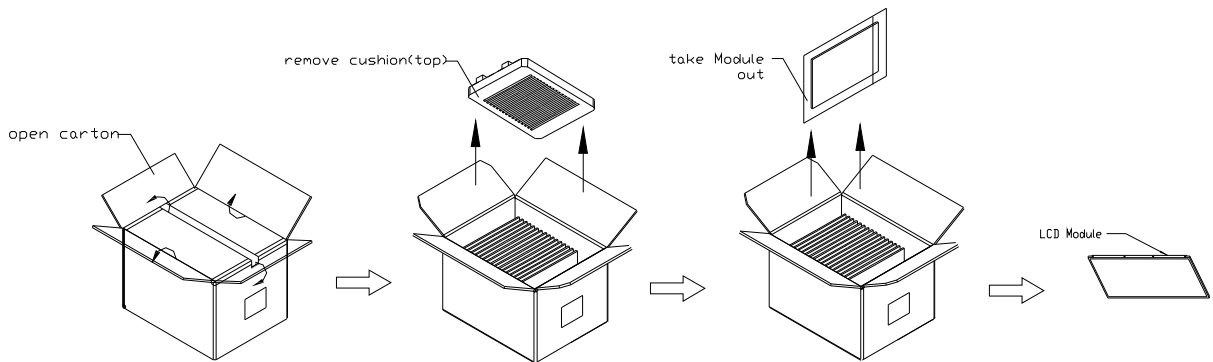
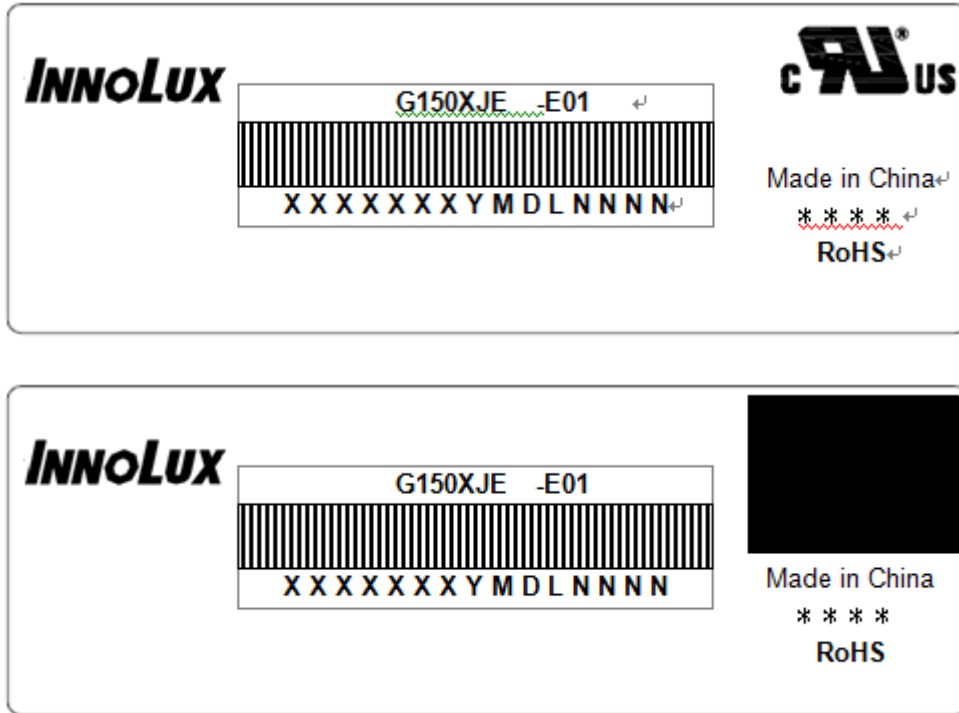

Figure. 6-3 UN-Packing method

**7. DEFINITION OF LABELS**

**7.1 INX MODULE LABEL**

The barcode nameplate is pasted on each module as illustration, and its definitions are as following explanation.



Note (1) Safety Compliance(UL logo) will open after C1 version.

(a) Model Name: G150XJE-E01

(b) \* \* \* \* : Factory ID

(c) Serial ID: X X X X X X Y M D X N N N N

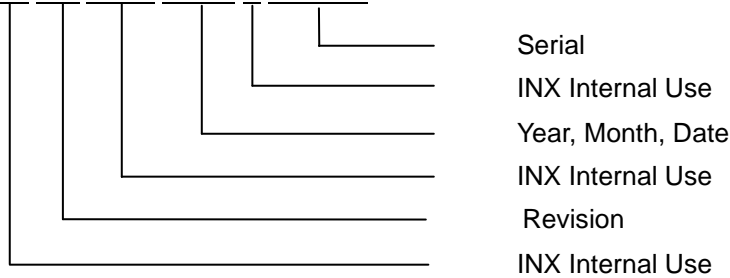

Serial ID includes the information as below:

- (a) Manufactured Date: Year: 1~9, for 2011~2019  
 Month: 1~9, A~C, for Jan. ~ Dec.  
 Day: 1~9, A~Y, for 1<sup>st</sup> to 31<sup>st</sup>, exclude I , O and U
- (b) Revision Code: cover all the change
- (c) Serial No.: Manufacturing sequence of product



## **8. PRECAUTIONS**

### **8.1 ASSEMBLY AND HANDLING PRECAUTIONS**

- (1) Do not apply rough force such as bending or twisting to the module during assembly.
- (2) To assemble or install module into user's system can be only in clean working areas. The dust and oil may cause electrical short or worsen the polarizer.
- (3) It's not permitted to have pressure or impulse on the module because the LCD panel and Backlight will be damaged.
- (4) Always follow the correct power sequence when LCD module is connecting and operating. This can prevent damage to the CMOS LSI chips during latch-up.
- (5) Do not pull the I/F connector in or out while the module is operating.
- (6) Do not disassemble the module.
- (7) Use a soft dry cloth without chemicals for cleaning, because the surface of polarizer is very soft and easily scratched.
- (8) It is dangerous that moisture come into or contacted the LCD module, because moisture may damage LCD module when it is operating.
- (9) High temperature or humidity may reduce the performance of module. Please store LCD module within the specified storage conditions.
- (10) When ambient temperature is lower than 10°C may reduce the display quality. For example, the response time will become slowly.
- (11) Do not keep same pattern in a long period of time. It may cause image sticking on LCD.

### **8.2 SAFETY PRECAUTIONS**

- (1) Do not disassemble the module or insert anything into the Backlight unit.
- (2) If the liquid crystal material leaks from the panel, it should be kept away from the eyes or mouth. In case of contact with hands, skin or clothes, it has to be washed away thoroughly with soap.
- (3) After the module's end of life, it is not harmful in case of normal operation and storage.

**9. MECHANICAL CHARACTERISTICS**

