



# SPECIFICATION

---

**AUO**  
AUO Display+

**G190ETN01.601**

19" – SXGA – LVDS

Version: 1.0  
Date: 16.02.2022

Note: This specification is subject to change without prior notice



AUO Display+

# Product Specification

G190ETN01.6

( ) Preliminary Specifications

( v ) Final Specifications

<b>Module</b>	19" Inch Color TFT-LCD
<b>Model Name</b>	G190ETN01.601

<b>Customer</b>	<b>Date</b>
_____	_____
<b>Checked &amp; Approved by</b>	<b>Date</b>
_____	_____
Customer's sign back page	

<b>Approved by</b>	<b>Date</b>
<u>Flossie Chuang</u>	<u>2022/11/09</u>
<b>Prepared by</b>	<b>Date</b>
<u>Daniel Chang</u>	<u>2022/11/09</u>
General Display Business Division / AUO Display Plus Corporation	



## Contents

<b>1. Operating Precautions</b> .....	<b>4</b>
<b>2. General Description</b> .....	<b>5</b>
2.1 Display Characteristics.....	5
2.2 Optical Characteristics .....	6
<b>3. Functional Block Diagram</b> .....	<b>9</b>
<b>4. Absolute Maximum Ratings</b> .....	<b>10</b>
4.1 Absolute Ratings of TFT LCD Module.....	10
4.2 Absolute Ratings of Environment.....	10
<b>5. Electrical Characteristics</b> .....	<b>11</b>
5.1 TFT LCD Module .....	11
5.2 Backlight Unit.....	13
<b>6. Signal Characteristic</b> .....	<b>15</b>
6.1 Pixel Format Image.....	15
6.2 Scanning Direction .....	錯誤! 尚未定義書籤。
6.3 Signal Description .....	16
6.4 The Input Data Format.....	18
6.5 Interface Timing .....	19
6.6 Power ON/OFF Sequence .....	21
<b>7. Reliability Test Criteria</b> .....	<b>22</b>
<b>8. Mechanical Characteristics</b> .....	<b>23</b>
8.1 LCM Outline Dimension .....	23
<b>9. Label and Packaging</b> .....	<b>24</b>
9.1 Shipping Label (on the rear side of TFT-LCD display).....	24
9.2 Carton Package .....	24
9.3 Palletizing Sequence .....	24

## Record of Revision

Version	Date (yyyy/mm/d)	Page	Old description	New Description																																																																																																																																																																																																																														
0.1	2021/09/03	All	First Preliminary Spec																																																																																																																																																																																																																															
0.2	2021/11/30	P13	<p><b>5.2 Backlight Unit</b></p> <ul style="list-style-type: none"> <li>5.2.1 LED Backlight Unit - Driver Connector</li> </ul> <p>Physical interface is described as for the connector on module. These connectors are capable of accommodating the following signals and will be following components.</p> <table border="1"> <thead> <tr> <th>Connector Name / Designation</th> <th>Lamp Connector</th> </tr> </thead> <tbody> <tr> <td>Manufacturer</td> <td>CvilLux</td> </tr> <tr> <td>Connector Model Number</td> <td>MS240110RHD</td> </tr> <tr> <td>Mating Model Number</td> <td>P240110H or compatible</td> </tr> </tbody> </table>	Connector Name / Designation	Lamp Connector	Manufacturer	CvilLux	Connector Model Number	MS240110RHD	Mating Model Number	P240110H or compatible	<p><b>5.2 Backlight Unit</b></p> <ul style="list-style-type: none"> <li>5.2.1 LED Backlight Unit - Driver Connector</li> </ul> <p>Physical interface is described as for the connector on module. These connectors are capable of accommodating the following signals and will be following components.</p> <table border="1"> <thead> <tr> <th>Connector Name / Designation</th> <th>Lamp Connector</th> </tr> </thead> <tbody> <tr> <td>Manufacturer</td> <td>STM</td> </tr> <tr> <td>Connector Model Number</td> <td>MS240110RHD</td> </tr> <tr> <td>Mating Model Number</td> <td>P240110H or compatible</td> </tr> </tbody> </table>	Connector Name / Designation	Lamp Connector	Manufacturer	STM	Connector Model Number	MS240110RHD	Mating Model Number	P240110H or compatible																																																																																																																																																																																																														
Connector Name / Designation	Lamp Connector																																																																																																																																																																																																																																	
Manufacturer	CvilLux																																																																																																																																																																																																																																	
Connector Model Number	MS240110RHD																																																																																																																																																																																																																																	
Mating Model Number	P240110H or compatible																																																																																																																																																																																																																																	
Connector Name / Designation	Lamp Connector																																																																																																																																																																																																																																	
Manufacturer	STM																																																																																																																																																																																																																																	
Connector Model Number	MS240110RHD																																																																																																																																																																																																																																	
Mating Model Number	P240110H or compatible																																																																																																																																																																																																																																	
		P14	<table border="1"> <thead> <tr> <th>Symbol</th> <th>Parameter</th> <th>Min.</th> <th>Typ.</th> <th>Max.</th> <th>Unit</th> <th>Remark</th> </tr> </thead> <tbody> <tr> <td>V<sub>CC</sub></td> <td>Input Voltage</td> <td>10.8</td> <td>12</td> <td>13.2</td> <td>Volt</td> <td>V<sub>CC</sub>=12V</td> </tr> <tr> <td>I<sub>CC</sub></td> <td>Input Current</td> <td>-</td> <td>2.50</td> <td>-</td> <td>A</td> <td>Ta=25°C at 100% V<sub>CC</sub>=12V</td> </tr> <tr> <td>P<sub>LED</sub></td> <td>Power Consumption</td> <td>-</td> <td>34</td> <td>39</td> <td>Watt</td> <td>Ta=25°C at 100%</td> </tr> <tr> <td>I<sub>inrush</sub></td> <td>Inrush Current</td> <td>-</td> <td>-</td> <td>TBD</td> <td>A</td> <td></td> </tr> <tr> <td>V<sub>LED on/off</sub></td> <td>On Control Voltage</td> <td>2</td> <td>3.3</td> <td>5</td> <td>Volt</td> <td rowspan="2">Back light on/off</td> </tr> <tr> <td></td> <td>Off Control Voltage</td> <td>0</td> <td>-</td> <td>0.6</td> <td>Volt</td> </tr> <tr> <td rowspan="4">E<sub>PMW</sub></td> <td>PWM Dimming Frequency</td> <td>200</td> <td>-</td> <td>20K</td> <td>Hz</td> <td></td> </tr> <tr> <td>High Voltage</td> <td>2</td> <td>3.3</td> <td>5</td> <td>Volt</td> <td></td> </tr> <tr> <td>Low Voltage</td> <td>0</td> <td>-</td> <td>0.6</td> <td>Volt</td> <td></td> </tr> <tr> <td>Dimming Duty Cycle</td> <td>20</td> <td>-</td> <td>100</td> <td>%</td> <td></td> </tr> <tr> <td>I<sub>F</sub></td> <td>LED Forward Current</td> <td>-</td> <td>75</td> <td>-</td> <td>mA</td> <td>Ta = 25°C (per string)</td> </tr> </tbody> </table>	Symbol	Parameter	Min.	Typ.	Max.	Unit	Remark	V <sub>CC</sub>	Input Voltage	10.8	12	13.2	Volt	V <sub>CC</sub> =12V	I <sub>CC</sub>	Input Current	-	2.50	-	A	Ta=25°C at 100% V <sub>CC</sub> =12V	P <sub>LED</sub>	Power Consumption	-	34	39	Watt	Ta=25°C at 100%	I <sub>inrush</sub>	Inrush Current	-	-	TBD	A		V <sub>LED on/off</sub>	On Control Voltage	2	3.3	5	Volt	Back light on/off		Off Control Voltage	0	-	0.6	Volt	E <sub>PMW</sub>	PWM Dimming Frequency	200	-	20K	Hz		High Voltage	2	3.3	5	Volt		Low Voltage	0	-	0.6	Volt		Dimming Duty Cycle	20	-	100	%		I <sub>F</sub>	LED Forward Current	-	75	-	mA	Ta = 25°C (per string)	<p><b>5.2.3 Backlight input signal characteristics</b></p> <table border="1"> <thead> <tr> <th>Symbol</th> <th>Parameter</th> <th>Min.</th> <th>Typ.</th> <th>Max.</th> <th>Unit</th> <th>Remark</th> </tr> </thead> <tbody> <tr> <td>V<sub>CC</sub></td> <td>Input Voltage</td> <td>10.8</td> <td>12</td> <td>13.2</td> <td>Volt</td> <td>V<sub>CC</sub>=12V</td> </tr> <tr> <td>I<sub>CC</sub></td> <td>Input Current</td> <td>-</td> <td>2.60</td> <td>-</td> <td>A</td> <td>Ta=25°C at 100% V<sub>CC</sub>=12V</td> </tr> <tr> <td>P<sub>LED</sub></td> <td>Power Consumption</td> <td>-</td> <td>34</td> <td>39</td> <td>Watt</td> <td>Ta=25°C at 100%</td> </tr> <tr> <td>I<sub>inrush</sub></td> <td>Inrush Current</td> <td>-</td> <td>-</td> <td>TBD</td> <td>A</td> <td></td> </tr> <tr> <td rowspan="2">V<sub>LED on/off</sub></td> <td>On Control Voltage</td> <td>2</td> <td>3.3</td> <td>5</td> <td>Volt</td> <td rowspan="2">Back light on/off</td> </tr> <tr> <td>Off Control Voltage</td> <td>0</td> <td>-</td> <td>0.6</td> <td>Volt</td> </tr> <tr> <td rowspan="4">E<sub>PMW</sub></td> <td>PWM Dimming Frequency</td> <td>200</td> <td>-</td> <td>20K</td> <td>Hz</td> <td></td> </tr> <tr> <td>High Voltage</td> <td>2</td> <td>3.3</td> <td>5</td> <td>Volt</td> <td></td> </tr> <tr> <td>Low Voltage</td> <td>0</td> <td>-</td> <td>0.6</td> <td>Volt</td> <td></td> </tr> <tr> <td>Dimming Duty 200-5K</td> <td>5</td> <td>-</td> <td>100</td> <td>%</td> <td></td> </tr> <tr> <td></td> <td>Dimming Duty 5K-20K</td> <td>15</td> <td>-</td> <td>100</td> <td>%</td> <td></td> </tr> <tr> <td>I<sub>F</sub></td> <td>LED Forward Current</td> <td>-</td> <td>75</td> <td>-</td> <td>mA</td> <td>Ta = 25°C (per string)</td> </tr> </tbody> </table>	Symbol	Parameter	Min.	Typ.	Max.	Unit	Remark	V <sub>CC</sub>	Input Voltage	10.8	12	13.2	Volt	V <sub>CC</sub> =12V	I <sub>CC</sub>	Input Current	-	2.60	-	A	Ta=25°C at 100% V <sub>CC</sub> =12V	P <sub>LED</sub>	Power Consumption	-	34	39	Watt	Ta=25°C at 100%	I <sub>inrush</sub>	Inrush Current	-	-	TBD	A		V <sub>LED on/off</sub>	On Control Voltage	2	3.3	5	Volt	Back light on/off	Off Control Voltage	0	-	0.6	Volt	E <sub>PMW</sub>	PWM Dimming Frequency	200	-	20K	Hz		High Voltage	2	3.3	5	Volt		Low Voltage	0	-	0.6	Volt		Dimming Duty 200-5K	5	-	100	%			Dimming Duty 5K-20K	15	-	100	%		I <sub>F</sub>	LED Forward Current	-	75	-	mA	Ta = 25°C (per string)																																																								
Symbol	Parameter	Min.	Typ.	Max.	Unit	Remark																																																																																																																																																																																																																												
V <sub>CC</sub>	Input Voltage	10.8	12	13.2	Volt	V <sub>CC</sub> =12V																																																																																																																																																																																																																												
I <sub>CC</sub>	Input Current	-	2.50	-	A	Ta=25°C at 100% V <sub>CC</sub> =12V																																																																																																																																																																																																																												
P <sub>LED</sub>	Power Consumption	-	34	39	Watt	Ta=25°C at 100%																																																																																																																																																																																																																												
I <sub>inrush</sub>	Inrush Current	-	-	TBD	A																																																																																																																																																																																																																													
V <sub>LED on/off</sub>	On Control Voltage	2	3.3	5	Volt	Back light on/off																																																																																																																																																																																																																												
	Off Control Voltage	0	-	0.6	Volt																																																																																																																																																																																																																													
E <sub>PMW</sub>	PWM Dimming Frequency	200	-	20K	Hz																																																																																																																																																																																																																													
	High Voltage	2	3.3	5	Volt																																																																																																																																																																																																																													
	Low Voltage	0	-	0.6	Volt																																																																																																																																																																																																																													
	Dimming Duty Cycle	20	-	100	%																																																																																																																																																																																																																													
I <sub>F</sub>	LED Forward Current	-	75	-	mA	Ta = 25°C (per string)																																																																																																																																																																																																																												
Symbol	Parameter	Min.	Typ.	Max.	Unit	Remark																																																																																																																																																																																																																												
V <sub>CC</sub>	Input Voltage	10.8	12	13.2	Volt	V <sub>CC</sub> =12V																																																																																																																																																																																																																												
I <sub>CC</sub>	Input Current	-	2.60	-	A	Ta=25°C at 100% V <sub>CC</sub> =12V																																																																																																																																																																																																																												
P <sub>LED</sub>	Power Consumption	-	34	39	Watt	Ta=25°C at 100%																																																																																																																																																																																																																												
I <sub>inrush</sub>	Inrush Current	-	-	TBD	A																																																																																																																																																																																																																													
V <sub>LED on/off</sub>	On Control Voltage	2	3.3	5	Volt	Back light on/off																																																																																																																																																																																																																												
	Off Control Voltage	0	-	0.6	Volt																																																																																																																																																																																																																													
E <sub>PMW</sub>	PWM Dimming Frequency	200	-	20K	Hz																																																																																																																																																																																																																													
	High Voltage	2	3.3	5	Volt																																																																																																																																																																																																																													
	Low Voltage	0	-	0.6	Volt																																																																																																																																																																																																																													
	Dimming Duty 200-5K	5	-	100	%																																																																																																																																																																																																																													
	Dimming Duty 5K-20K	15	-	100	%																																																																																																																																																																																																																													
I <sub>F</sub>	LED Forward Current	-	75	-	mA	Ta = 25°C (per string)																																																																																																																																																																																																																												
		P19	<table border="1"> <thead> <tr> <th>Signal</th> <th>Symbol</th> <th>Min.</th> <th>Typ.</th> <th>Max.</th> <th>Unit</th> </tr> </thead> <tbody> <tr> <td rowspan="2">Clock</td> <td>Period</td> <td>T<sub>clk</sub></td> <td>44</td> <td>54</td> <td>67.5</td> <td>MHz</td> </tr> <tr> <td>Frequency</td> <td>F<sub>req</sub></td> <td>22.2</td> <td>18.52</td> <td>14.81</td> <td>ns</td> </tr> <tr> <td rowspan="2">Vertical-Section</td> <td>Period</td> <td>T<sub>v</sub></td> <td>1032</td> <td>1066</td> <td>1150</td> <td>ns</td> </tr> <tr> <td>Active</td> <td>T<sub>vp</sub></td> <td>1024</td> <td>1024</td> <td>1024</td> <td>T<sub>use</sub></td> </tr> <tr> <td rowspan="4">Horizontal-Section</td> <td>Blanking</td> <td>T<sub>ve</sub></td> <td>8</td> <td>42</td> <td>126</td> <td>ns</td> </tr> <tr> <td>Period</td> <td>T<sub>hp</sub></td> <td>780</td> <td>844</td> <td>2047</td> <td>ns</td> </tr> <tr> <td>Active</td> <td>T<sub>hp</sub></td> <td>640</td> <td>640</td> <td>640</td> <td>T<sub>use</sub></td> </tr> <tr> <td>Blanking</td> <td>T<sub>hp</sub></td> <td>140</td> <td>204</td> <td>-</td> <td>ns</td> </tr> <tr> <td>Frame Rate</td> <td>F<sub>r</sub></td> <td>49</td> <td>60</td> <td>75</td> <td>Hz</td> </tr> </tbody> </table> <p>Note : DE mode only</p>	Signal	Symbol	Min.	Typ.	Max.	Unit	Clock	Period	T <sub>clk</sub>	44	54	67.5	MHz	Frequency	F <sub>req</sub>	22.2	18.52	14.81	ns	Vertical-Section	Period	T <sub>v</sub>	1032	1066	1150	ns	Active	T <sub>vp</sub>	1024	1024	1024	T <sub>use</sub>	Horizontal-Section	Blanking	T <sub>ve</sub>	8	42	126	ns	Period	T <sub>hp</sub>	780	844	2047	ns	Active	T <sub>hp</sub>	640	640	640	T <sub>use</sub>	Blanking	T <sub>hp</sub>	140	204	-	ns	Frame Rate	F <sub>r</sub>	49	60	75	Hz	<table border="1"> <thead> <tr> <th>Signal</th> <th>Symbol</th> <th>Min.</th> <th>Typ.</th> <th>Max.</th> <th>Unit</th> </tr> </thead> <tbody> <tr> <td rowspan="2">Clock</td> <td>Period</td> <td>T<sub>clk</sub></td> <td>22.2</td> <td>18.52</td> <td>14.81</td> <td>ns</td> </tr> <tr> <td>Frequency</td> <td>F<sub>req</sub></td> <td>44</td> <td>54</td> <td>67.5</td> <td>MHz</td> </tr> <tr> <td rowspan="2">Vertical-Section</td> <td>Period</td> <td>T<sub>v</sub></td> <td>1032</td> <td>1066</td> <td>1150</td> <td>ns</td> </tr> <tr> <td>Active</td> <td>T<sub>vp</sub></td> <td>1024</td> <td>1024</td> <td>1024</td> <td>T<sub>use</sub></td> </tr> <tr> <td rowspan="4">Horizontal-Section</td> <td>Blanking</td> <td>T<sub>ve</sub></td> <td>8</td> <td>42</td> <td>126</td> <td>ns</td> </tr> <tr> <td>Period</td> <td>T<sub>hp</sub></td> <td>780</td> <td>844</td> <td>2047</td> <td>ns</td> </tr> <tr> <td>Active</td> <td>T<sub>hp</sub></td> <td>640</td> <td>640</td> <td>640</td> <td>T<sub>use</sub></td> </tr> <tr> <td>Blanking</td> <td>T<sub>hp</sub></td> <td>140</td> <td>204</td> <td>-</td> <td>ns</td> </tr> <tr> <td>Frame Rate</td> <td>F<sub>r</sub></td> <td>49</td> <td>60</td> <td>75</td> <td>Hz</td> </tr> </tbody> </table>	Signal	Symbol	Min.	Typ.	Max.	Unit	Clock	Period	T <sub>clk</sub>	22.2	18.52	14.81	ns	Frequency	F <sub>req</sub>	44	54	67.5	MHz	Vertical-Section	Period	T <sub>v</sub>	1032	1066	1150	ns	Active	T <sub>vp</sub>	1024	1024	1024	T <sub>use</sub>	Horizontal-Section	Blanking	T <sub>ve</sub>	8	42	126	ns	Period	T <sub>hp</sub>	780	844	2047	ns	Active	T <sub>hp</sub>	640	640	640	T <sub>use</sub>	Blanking	T <sub>hp</sub>	140	204	-	ns	Frame Rate	F <sub>r</sub>	49	60	75	Hz																																																																																																
Signal	Symbol	Min.	Typ.	Max.	Unit																																																																																																																																																																																																																													
Clock	Period	T <sub>clk</sub>	44	54	67.5	MHz																																																																																																																																																																																																																												
	Frequency	F <sub>req</sub>	22.2	18.52	14.81	ns																																																																																																																																																																																																																												
Vertical-Section	Period	T <sub>v</sub>	1032	1066	1150	ns																																																																																																																																																																																																																												
	Active	T <sub>vp</sub>	1024	1024	1024	T <sub>use</sub>																																																																																																																																																																																																																												
Horizontal-Section	Blanking	T <sub>ve</sub>	8	42	126	ns																																																																																																																																																																																																																												
	Period	T <sub>hp</sub>	780	844	2047	ns																																																																																																																																																																																																																												
	Active	T <sub>hp</sub>	640	640	640	T <sub>use</sub>																																																																																																																																																																																																																												
	Blanking	T <sub>hp</sub>	140	204	-	ns																																																																																																																																																																																																																												
Frame Rate	F <sub>r</sub>	49	60	75	Hz																																																																																																																																																																																																																													
Signal	Symbol	Min.	Typ.	Max.	Unit																																																																																																																																																																																																																													
Clock	Period	T <sub>clk</sub>	22.2	18.52	14.81	ns																																																																																																																																																																																																																												
	Frequency	F <sub>req</sub>	44	54	67.5	MHz																																																																																																																																																																																																																												
Vertical-Section	Period	T <sub>v</sub>	1032	1066	1150	ns																																																																																																																																																																																																																												
	Active	T <sub>vp</sub>	1024	1024	1024	T <sub>use</sub>																																																																																																																																																																																																																												
Horizontal-Section	Blanking	T <sub>ve</sub>	8	42	126	ns																																																																																																																																																																																																																												
	Period	T <sub>hp</sub>	780	844	2047	ns																																																																																																																																																																																																																												
	Active	T <sub>hp</sub>	640	640	640	T <sub>use</sub>																																																																																																																																																																																																																												
	Blanking	T <sub>hp</sub>	140	204	-	ns																																																																																																																																																																																																																												
Frame Rate	F <sub>r</sub>	49	60	75	Hz																																																																																																																																																																																																																													
1.0	20221109	P1	Preliminary spec	Final Spec																																																																																																																																																																																																																														
		P24	<p><b>9. Label and Packaging</b></p> <p><b>9.1 Shipping Label</b> (on the rear side of TFT-LCD display)</p>																																																																																																																																																																																																																															
		P6	<p><b>2.2 Optical Characteristics</b></p> <p>The optical characteristics are measured under stable conditions at 25°C (Room Temperature).</p> <table border="1"> <thead> <tr> <th>Item</th> <th>Unit</th> <th>Conditions</th> <th>Min.</th> <th>Typ.</th> <th>Max.</th> <th>Note</th> </tr> </thead> <tbody> <tr> <td>White Luminance</td> <td>cd/m<sup>2</sup></td> <td>L<sub>w</sub>=75mA(center point)</td> <td>1280</td> <td>1600</td> <td>-</td> <td>1</td> </tr> <tr> <td>Uniformity</td> <td>%</td> <td>9 points</td> <td>75</td> <td>80</td> <td>-</td> <td>2,3</td> </tr> <tr> <td>Contrast Ratio</td> <td>-</td> <td>-</td> <td>600</td> <td>1000</td> <td>-</td> <td>4</td> </tr> <tr> <td rowspan="2">Response Time</td> <td rowspan="2">msec</td> <td>Rising</td> <td>-</td> <td>-</td> <td>-</td> <td>-</td> </tr> <tr> <td>Falling</td> <td>-</td> <td>-</td> <td>-</td> <td>-</td> </tr> <tr> <td></td> <td></td> <td>Rising + Falling</td> <td>-</td> <td>10</td> <td>20</td> <td>5</td> </tr> <tr> <td rowspan="4">Viewing Angle</td> <td rowspan="4">degree</td> <td rowspan="2">Horizontal- CR &gt;= 10°</td> <td>(Right)</td> <td>75</td> <td>85</td> <td>-</td> <td rowspan="2">6</td> </tr> <tr> <td>(Left)</td> <td>75</td> <td>85</td> <td>-</td> </tr> <tr> <td rowspan="2">Vertical- CR &gt;= 5°</td> <td>(Upper)</td> <td>70</td> <td>80</td> <td>-</td> <td rowspan="2">6</td> </tr> <tr> <td>(Lower)</td> <td>70</td> <td>80</td> <td>-</td> </tr> <tr> <td rowspan="6">Color / Chromaticity Coordinates (CIE 1931)</td> <td rowspan="6">-</td> <td>Red x<sup>o</sup></td> <td>TBD</td> <td>TBD</td> <td>TBD</td> <td rowspan="6">4</td> </tr> <tr> <td>Red y<sup>o</sup></td> <td>TBD</td> <td>TBD</td> <td>TBD</td> </tr> <tr> <td>Green x<sup>o</sup></td> <td>TBD</td> <td>TBD</td> <td>TBD</td> </tr> <tr> <td>Green y<sup>o</sup></td> <td>TBD</td> <td>TBD</td> <td>TBD</td> </tr> <tr> <td>Blue x<sup>o</sup></td> <td>TBD</td> <td>TBD</td> <td>TBD</td> </tr> <tr> <td>Blue y<sup>o</sup></td> <td>TBD</td> <td>TBD</td> <td>TBD</td> </tr> <tr> <td>White x<sup>o</sup></td> <td>0.260</td> <td>0.310</td> <td>0.360</td> <td rowspan="2">-</td> </tr> <tr> <td>White y<sup>o</sup></td> <td>0.270</td> <td>0.320</td> <td>0.370</td> </tr> <tr> <td>Color Gamut</td> <td>%</td> <td>-</td> <td>70</td> <td>-</td> <td>-</td> </tr> </tbody> </table>	Item	Unit	Conditions	Min.	Typ.	Max.	Note	White Luminance	cd/m <sup>2</sup>	L <sub>w</sub> =75mA(center point)	1280	1600	-	1	Uniformity	%	9 points	75	80	-	2,3	Contrast Ratio	-	-	600	1000	-	4	Response Time	msec	Rising	-	-	-	-	Falling	-	-	-	-			Rising + Falling	-	10	20	5	Viewing Angle	degree	Horizontal- CR >= 10°	(Right)	75	85	-	6	(Left)	75	85	-	Vertical- CR >= 5°	(Upper)	70	80	-	6	(Lower)	70	80	-	Color / Chromaticity Coordinates (CIE 1931)	-	Red x <sup>o</sup>	TBD	TBD	TBD	4	Red y <sup>o</sup>	TBD	TBD	TBD	Green x <sup>o</sup>	TBD	TBD	TBD	Green y <sup>o</sup>	TBD	TBD	TBD	Blue x <sup>o</sup>	TBD	TBD	TBD	Blue y <sup>o</sup>	TBD	TBD	TBD	White x <sup>o</sup>	0.260	0.310	0.360	-	White y <sup>o</sup>	0.270	0.320	0.370	Color Gamut	%	-	70	-	-	<p><b>2.2 Optical Characteristics</b></p> <p>The optical characteristics are measured under stable conditions at 25°C (Room Temperature).</p> <table border="1"> <thead> <tr> <th>Item</th> <th>Unit</th> <th>Conditions</th> <th>Min.</th> <th>Typ.</th> <th>Max.</th> <th>Note</th> </tr> </thead> <tbody> <tr> <td>White Luminance</td> <td>cd/m<sup>2</sup></td> <td>L<sub>w</sub>=75mA(center point)</td> <td>1280</td> <td>1600</td> <td>-</td> <td>1</td> </tr> <tr> <td>Uniformity</td> <td>%</td> <td>9 points</td> <td>75</td> <td>80</td> <td>-</td> <td>2,3</td> </tr> <tr> <td>Contrast Ratio</td> <td>-</td> <td>-</td> <td>600</td> <td>1000</td> <td>-</td> <td>4</td> </tr> <tr> <td rowspan="2">Response Time</td> <td rowspan="2">msec</td> <td>Rising</td> <td>-</td> <td>-</td> <td>-</td> <td>-</td> </tr> <tr> <td>Falling</td> <td>-</td> <td>-</td> <td>-</td> <td>-</td> </tr> <tr> <td></td> <td></td> <td>Rising + Falling</td> <td>-</td> <td>10</td> <td>20</td> <td>5</td> </tr> <tr> <td rowspan="4">Viewing Angle</td> <td rowspan="4">degree</td> <td rowspan="2">Horizontal- CR &gt;= 10°</td> <td>(Right)</td> <td>75</td> <td>85</td> <td>-</td> <td rowspan="2">6</td> </tr> <tr> <td>(Left)</td> <td>75</td> <td>85</td> <td>-</td> </tr> <tr> <td rowspan="2">Vertical- CR &gt;= 5°</td> <td>(Upper)</td> <td>70</td> <td>80</td> <td>-</td> <td rowspan="2">6</td> </tr> <tr> <td>(Lower)</td> <td>70</td> <td>80</td> <td>-</td> </tr> <tr> <td rowspan="6">Color / Chromaticity Coordinates (CIE 1931)</td> <td rowspan="6">-</td> <td>Red x<sup>o</sup></td> <td>0.590</td> <td>0.640</td> <td>0.690</td> <td rowspan="6">-</td> </tr> <tr> <td>Red y<sup>o</sup></td> <td>0.295</td> <td>0.345</td> <td>0.395</td> </tr> <tr> <td>Green x<sup>o</sup></td> <td>0.275</td> <td>0.325</td> <td>0.375</td> </tr> <tr> <td>Green y<sup>o</sup></td> <td>0.571</td> <td>0.621</td> <td>0.671</td> </tr> <tr> <td>Blue x<sup>o</sup></td> <td>0.100</td> <td>0.150</td> <td>0.200</td> </tr> <tr> <td>Blue y<sup>o</sup></td> <td>0.020</td> <td>0.070</td> <td>0.120</td> </tr> <tr> <td>White x<sup>o</sup></td> <td>0.260</td> <td>0.310</td> <td>0.360</td> <td rowspan="2">-</td> </tr> <tr> <td>White y<sup>o</sup></td> <td>0.270</td> <td>0.320</td> <td>0.370</td> </tr> <tr> <td>Color Gamut</td> <td>%</td> <td>-</td> <td>70</td> <td>-</td> <td>-</td> </tr> </tbody> </table>	Item	Unit	Conditions	Min.	Typ.	Max.	Note	White Luminance	cd/m <sup>2</sup>	L <sub>w</sub> =75mA(center point)	1280	1600	-	1	Uniformity	%	9 points	75	80	-	2,3	Contrast Ratio	-	-	600	1000	-	4	Response Time	msec	Rising	-	-	-	-	Falling	-	-	-	-			Rising + Falling	-	10	20	5	Viewing Angle	degree	Horizontal- CR >= 10°	(Right)	75	85	-	6	(Left)	75	85	-	Vertical- CR >= 5°	(Upper)	70	80	-	6	(Lower)	70	80	-	Color / Chromaticity Coordinates (CIE 1931)	-	Red x <sup>o</sup>	0.590	0.640	0.690	-	Red y <sup>o</sup>	0.295	0.345	0.395	Green x <sup>o</sup>	0.275	0.325	0.375	Green y <sup>o</sup>	0.571	0.621	0.671	Blue x <sup>o</sup>	0.100	0.150	0.200	Blue y <sup>o</sup>	0.020	0.070	0.120	White x <sup>o</sup>	0.260	0.310	0.360	-	White y <sup>o</sup>	0.270	0.320	0.370	Color Gamut	%	-	70	-	-
Item	Unit	Conditions	Min.	Typ.	Max.	Note																																																																																																																																																																																																																												
White Luminance	cd/m <sup>2</sup>	L <sub>w</sub> =75mA(center point)	1280	1600	-	1																																																																																																																																																																																																																												
Uniformity	%	9 points	75	80	-	2,3																																																																																																																																																																																																																												
Contrast Ratio	-	-	600	1000	-	4																																																																																																																																																																																																																												
Response Time	msec	Rising	-	-	-	-																																																																																																																																																																																																																												
		Falling	-	-	-	-																																																																																																																																																																																																																												
		Rising + Falling	-	10	20	5																																																																																																																																																																																																																												
Viewing Angle	degree	Horizontal- CR >= 10°	(Right)	75	85	-	6																																																																																																																																																																																																																											
			(Left)	75	85	-																																																																																																																																																																																																																												
		Vertical- CR >= 5°	(Upper)	70	80	-	6																																																																																																																																																																																																																											
			(Lower)	70	80	-																																																																																																																																																																																																																												
Color / Chromaticity Coordinates (CIE 1931)	-	Red x <sup>o</sup>	TBD	TBD	TBD	4																																																																																																																																																																																																																												
		Red y <sup>o</sup>	TBD	TBD	TBD																																																																																																																																																																																																																													
		Green x <sup>o</sup>	TBD	TBD	TBD																																																																																																																																																																																																																													
		Green y <sup>o</sup>	TBD	TBD	TBD																																																																																																																																																																																																																													
		Blue x <sup>o</sup>	TBD	TBD	TBD																																																																																																																																																																																																																													
		Blue y <sup>o</sup>	TBD	TBD	TBD																																																																																																																																																																																																																													
White x <sup>o</sup>	0.260	0.310	0.360	-																																																																																																																																																																																																																														
White y <sup>o</sup>	0.270	0.320	0.370																																																																																																																																																																																																																															
Color Gamut	%	-	70	-	-																																																																																																																																																																																																																													
Item	Unit	Conditions	Min.	Typ.	Max.	Note																																																																																																																																																																																																																												
White Luminance	cd/m <sup>2</sup>	L <sub>w</sub> =75mA(center point)	1280	1600	-	1																																																																																																																																																																																																																												
Uniformity	%	9 points	75	80	-	2,3																																																																																																																																																																																																																												
Contrast Ratio	-	-	600	1000	-	4																																																																																																																																																																																																																												
Response Time	msec	Rising	-	-	-	-																																																																																																																																																																																																																												
		Falling	-	-	-	-																																																																																																																																																																																																																												
		Rising + Falling	-	10	20	5																																																																																																																																																																																																																												
Viewing Angle	degree	Horizontal- CR >= 10°	(Right)	75	85	-	6																																																																																																																																																																																																																											
			(Left)	75	85	-																																																																																																																																																																																																																												
		Vertical- CR >= 5°	(Upper)	70	80	-	6																																																																																																																																																																																																																											
			(Lower)	70	80	-																																																																																																																																																																																																																												
Color / Chromaticity Coordinates (CIE 1931)	-	Red x <sup>o</sup>	0.590	0.640	0.690	-																																																																																																																																																																																																																												
		Red y <sup>o</sup>	0.295	0.345	0.395																																																																																																																																																																																																																													
		Green x <sup>o</sup>	0.275	0.325	0.375																																																																																																																																																																																																																													
		Green y <sup>o</sup>	0.571	0.621	0.671																																																																																																																																																																																																																													
		Blue x <sup>o</sup>	0.100	0.150	0.200																																																																																																																																																																																																																													
		Blue y <sup>o</sup>	0.020	0.070	0.120																																																																																																																																																																																																																													
White x <sup>o</sup>	0.260	0.310	0.360	-																																																																																																																																																																																																																														
White y <sup>o</sup>	0.270	0.320	0.370																																																																																																																																																																																																																															
Color Gamut	%	-	70	-	-																																																																																																																																																																																																																													

## 1. Operating Precautions

- 1) Since front polarizer is easily damaged, please be cautious and not to scratch it.
- 2) Be sure to turn off power supply when inserting or disconnecting from input connector.
- 3) Wipe off water drop immediately. Long contact with water may cause discoloration or spots.
- 4) When the panel surface is soiled, wipe it with absorbent cotton or soft cloth.
- 5) Since the panel is made of glass, it may be broken or cracked if dropped or bumped on hard surface.
- 6) To avoid ESD (Electro Static Discharge) damage, be sure to ground yourself before handling TFT-LCD Module.
- 7) Do not open nor modify the module assembly.
- 8) Do not press the reflector sheet at the back of the module to any direction.
- 9) In case if a module has to be put back into the packing container slot after it was taken out from the container, do not press the center of the LED light bar edge. Instead, press at the far ends of the LED light bar edge softly. Otherwise the TFT Module may be damaged.
- 10) At the insertion or removal of the Signal Interface Connector, be sure not to rotate nor tilt the Interface Connector of the TFT Module.
- 11) TFT-LCD Module is not allowed to be twisted & bent even force is added on module in a very short time. Please design your display product well to avoid external force applying to module by end-user directly.
- 12) Small amount of materials without flammability grade are used in the TFT-LCD module. The TFT-LCD module should be supplied by power complied with requirements of Limited Power Source (IEC60950 or UL1950), or be applied exemption.
- 13) Severe temperature condition may result in different luminance, response time and lamp ignition voltage.
- 14) Continuous operating TFT-LCD display under low temperature environment may accelerate lamp exhaustion and reduce luminance dramatically.
- 15) The data on this specification sheet is applicable when LCD module is placed in landscape position.
- 16) Continuous displaying fixed pattern may induce image sticking. It's recommended to use screen saver or shuffle content periodically if fixed pattern is displayed on the screen.
- 17) Highlight model usage, please be careful the high temperature burn prevention.

## 2. General Description

G190ETN01.6 is a Color Active Matrix Liquid Crystal Display composed of a TFT-LCD panel, a driver circuit, and a backlight system. The screen format is intended to support the SXGA (1280(H) x 1024(V)) screen and 16.7M colors (RGB 6-bits + HiFRC data). All input signals are 2-channel LVDS interface.

### 2.1 Display Characteristics

The following items are characteristics summary on the table under 25 °C condition:

Items	Unit	Specifications
Screen Diagonal	[inch]	19"
Active Area	[mm]	376.32 (H) x 301.06 (V)
Resolution		1280(x3) x 1024
Pixel Pitch	[mm]	0.294 (per one triad) x 0.294
Pixel Arrangement		R.G.B. Vertical Stripe
Display Mode		TN
Nominal Input Voltage VDD	[Volt]	+5.0 V
Power Consumption	[Watt]	37.7W LCD : 6W(max) BLU Power : 31.7W(max)
Weight	[Grams]	Max 1800
Physical Size	[mm]	396 (H) x 324.26 (V) x 15.3 (D) (Typ)
Electrical Interface		Dual channel LVDS
Surface Treatment		Anti- Reflection, Hardness 2H
Support Color		16.7M colors (RGB 6-bit + Hi_FRC)
Temperature Range Operating Storage (Non-Operating)	[°C] [°C]	-30 to +70 -30 to +70
RoHS Compliance		Yes

## 2.2 Optical Characteristics

The optical characteristics are measured under stable conditions at 25 °C (Room Temperature):

Item	Unit	Conditions	Min.	Typ.	Max.	Note	
White Luminance	cd/m <sup>2</sup>	I <sub>LED</sub> =75mA(center point)	1280	1600	-	1	
Uniformity	%	9 points	75	80	-	2,3	
Contrast Ratio	--		600	1000	-	4	
Response Time	msec	Rising	-	-	-	5	
		Falling	-	-	-		
		Rising + Falling	-	10	20		
Viewing Angle	degree	Horizontal CR >= 10	(Right)	75	85	-	6
			(Left)	75	85	-	
		Vertical CR >= 5	(Upper)	70	80	-	
			(Lower)	70	80	-	
Color / Chromaticity Coordinates (CIE 1931)	--	Red x	0.590	0.640	0.690		
		Red y	0.295	0.345	0.395		
		Green x	0.275	0.325	0.375		
		Green y	0.571	0.621	0.671		
		Blue x	0.100	0.150	0.200		
		Blue y	0.020	0.070	0.120		
		White x	0.260	0.310	0.360		
		White y	0.270	0.320	0.370		
Color Gamut	%			70			

Note 1: Measurement method

Equipment Pattern Generator, Power Supply, Digital Voltmeter, Luminance meter (SR\_3 or equivalent)

Aperture 1° with 50cm viewing distance

Test Point Center

Environment < 1 lux

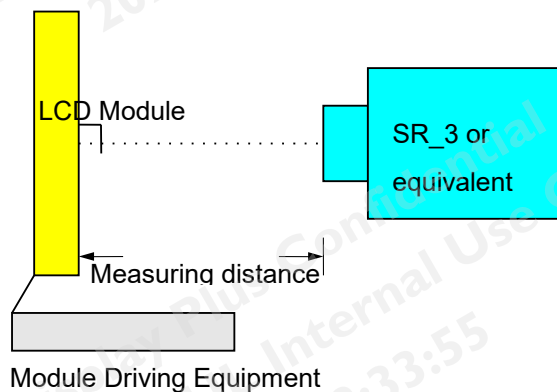

Note 2: Definition of 9 points position

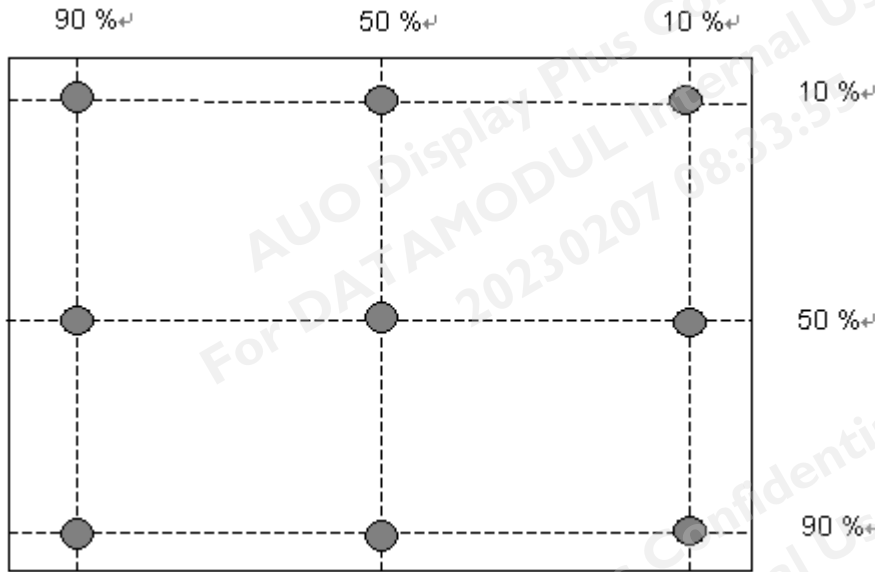

Note 3: The luminance uniformity of 9 points is defined by dividing the minimum luminance values by the maximum test point luminance

$$\text{Uniformity} = \frac{\text{Minimum Brightness of nine points}}{\text{Maximum Brightness of nine points}}$$

Note 4: Definition of contrast ratio (CR):

$$\text{Contrast ratio (CR)} = \frac{\text{Brightness on the "White" state}}{\text{Brightness on the "Black" state}}$$

Note 5: Definition of response time:

The output signals of photo detector are measured when the input signals are changed from "White" to "Black" (falling time) and from "Black" to "White" (rising time), respectively. The response time interval is between 10% and 90% of amplitudes. Please refer to the figure as below.

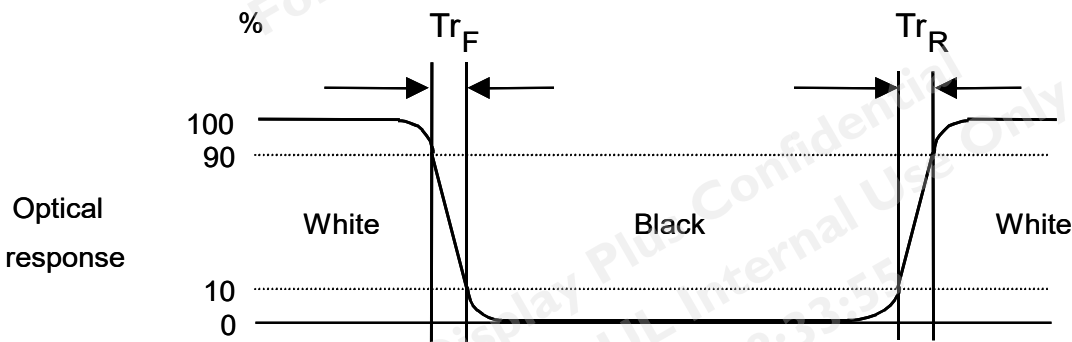



**AUO Display+**

**Note 6: Definition of viewing angle**

Viewing angle is the measurement of contrast ratio  $\geq 10$ , at the screen center, over a  $180^\circ$  horizontal and  $180^\circ$  vertical range (off-normal viewing angles). The  $180^\circ$  viewing angle range is broken down as below:  $90^\circ$  ( $\theta$ ) horizontal left and right, and  $90^\circ$  ( $\Phi$ ) vertical high (up) and low (down). The measurement direction is typically perpendicular to the display surface with the screen rotated to its center to develop the desired measurement viewing angle.

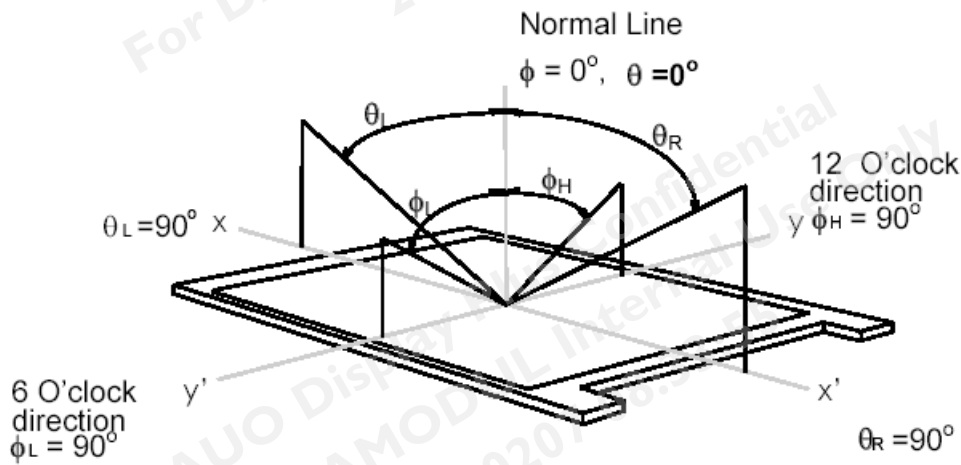

### 3. Functional Block Diagram

The following diagram shows the functional block of the 19.0 inch color TFT/LCD module:

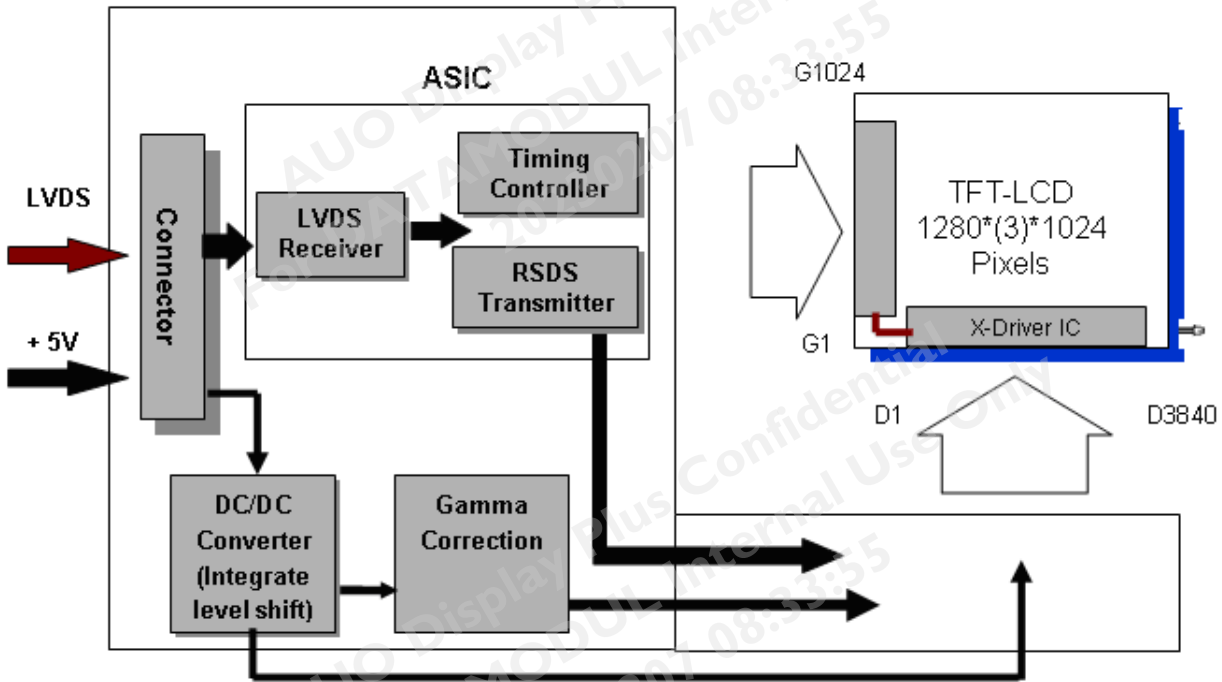

## 4. Absolute Maximum Ratings

### 4.1 Absolute Ratings of TFT LCD Module

Item	Symbol	Min	Max	Unit
Logic/LCD drive Voltage	Vin	-0.3	+6.0	[Volt]

Note: With in Ta (25 °C)

### 4.2 Absolute Ratings of Environment

Item	Symbol	Min	Max	Unit
Operating Temperature	TOP	-30	+70	[°C]
Operation Humidity	HOP	5	95	[%RH]
Storage Temperature	TST	-30	+70	[°C]
Storage Humidity	HST	5	95	[%RH]

Note: Maximum Wet-Bulb should be 39 °C and no condensation.

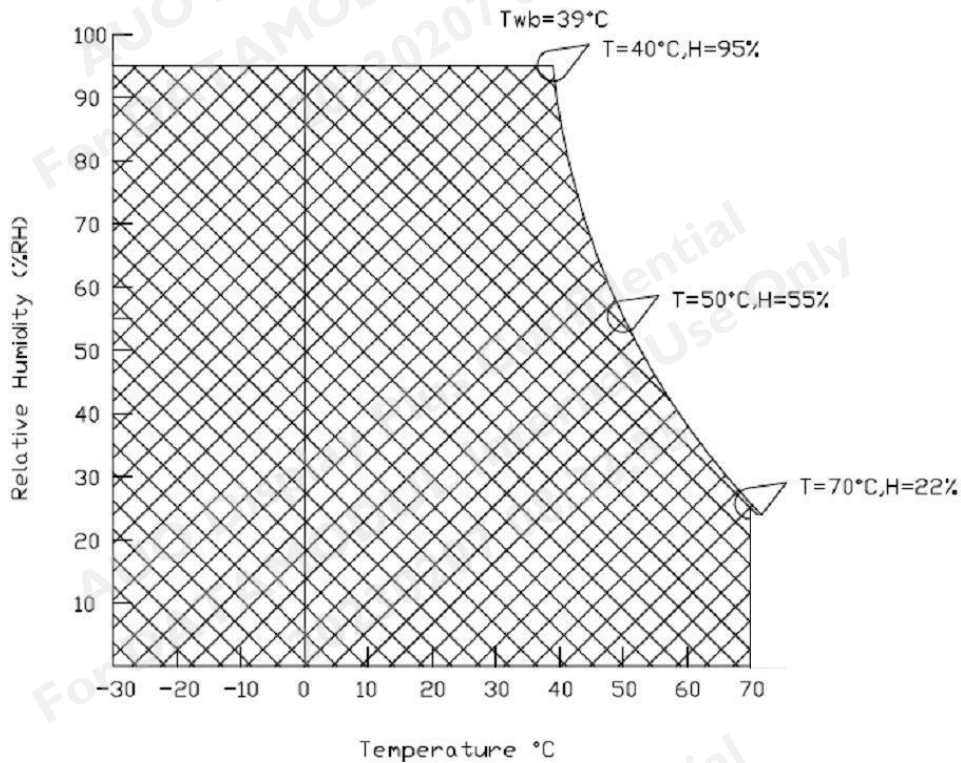

## 5. Electrical Characteristics

### 5.1 TFT LCD Module

#### 5.1.1 Power Specification

Input power specifications are shown as follows ;

Symbol	Parameter	Min	Typ	Max	Units	Remark
VDD	Logic/LCD Drive Voltage	4.5	5.0	5.5	[Volt]	+/-10%
IDD	Input Current	-	1	1.2	[A]	VDD= 5.0V, All Black Pattern At 75Hz
PDD	VDD Power	-	5	6	[Watt]	VDD= 5.0V, All Black Pattern At 75Hz
IRush	Inrush Current	-	-	3.0	[A]	Note 1
VDDrp	Allowable Logic/LCD Drive Ripple Voltage	-	-	100	[mV] p-p	VDD= 5.0V, All Black Pattern At 75Hz

Note 1: Measurement condition:

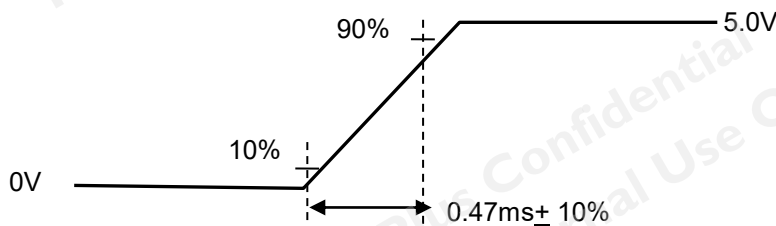
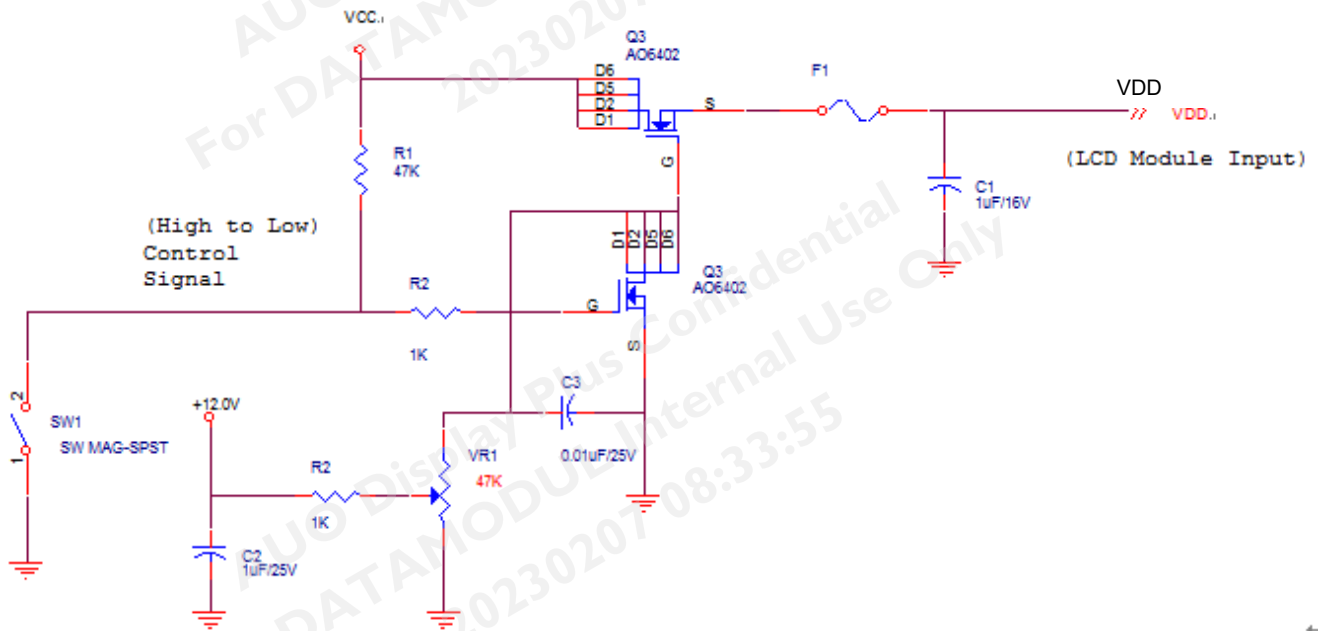

VDD rising time



## 5.1.2 LVDS DC Signal Electrical Characteristics

Please refer to specifications of SN75LVDS82DGG (Texas Instruments) in detail.

Symbol	Item	Min.	Typ.	Max.	Unit	Remark
$V_{TH}$	Differential Input High Threshold	-	-	+100	[mV]	$V_{CM}=1.2V$ , <b>Note</b>
$V_{TL}$	Differential Input Low Threshold	-100	-	-	[mV]	$V_{CM}=1.2V$ , <b>Note</b>
$ V_{ID} $	Input Differential Voltage	100	400	600	[mV]	<b>Note</b>
$V_{ICM}$	Differential Input Common Mode Voltage	+1.0	+1.2	+1.5	[V]	$V_{TH}/V_{TL}=\pm 100mV$ , <b>Note</b>

Input signals shall be low or Hi-Z state when VDD is off.

Note: LVDS Signal Waveform.

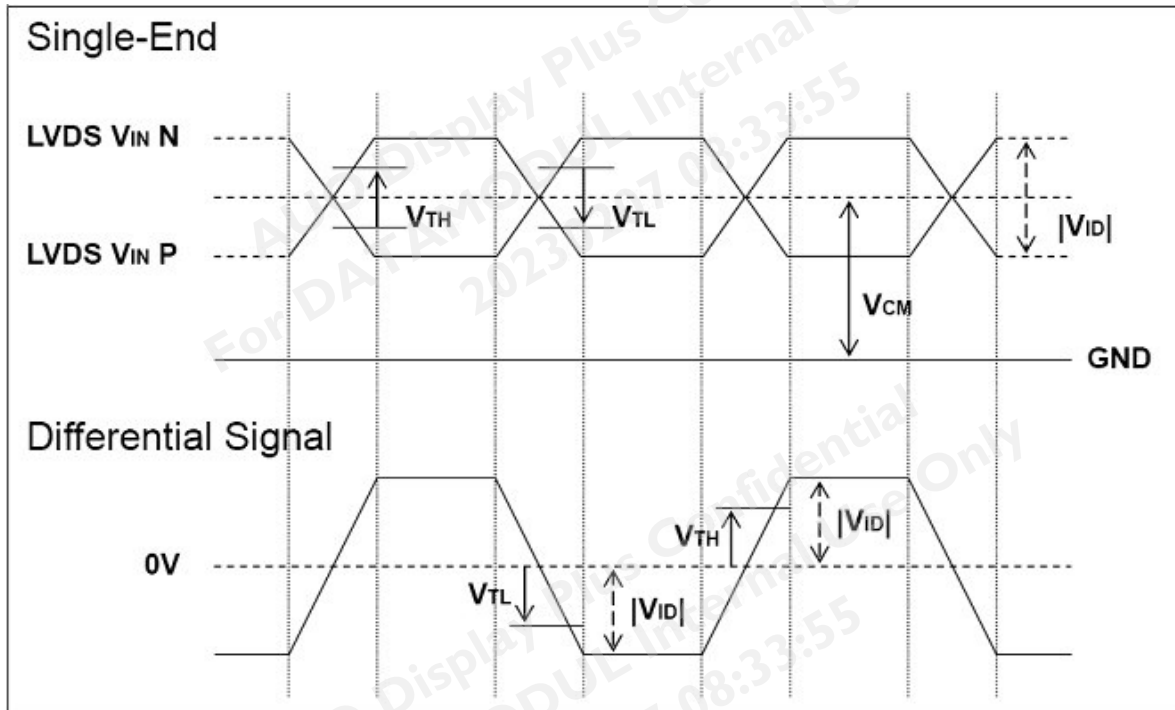

## 5.2 Backlight Unit

### 5.2.1 LED Backlight Unit : Driver Connector

Physical interface is described as for the connector on module. These connectors are capable of accommodating the following signals and will be following components.

<b>Connector Name / Designation</b>	<b>Lamp Connector</b>
Manufacturer	STM
Connector Model Number	MS240110RHD
Mating Model Number	P240110H or compatible

Pin No.	Symbol	Description
1	Vcc	12V
2	Vcc	12V
3	Vcc	12V
4	Vcc	12V
5	GND	GND
6	GND	GND
7	GND	GND
8	GND	GND
9	Enable	3.3V-On / 0V-Off
10	Dimming	PWM Dimming

### 5.2.2 LED characteristics

Following characteristics are measured under a stable condition using an inverter at 25°C (Room Temperature):

Symbol	Parameter	Min	Typ	Max	Units	Condition
PLED	Backlight Power Consumption	-	23.4	27	[Watt]	VCC=12V ,100% Dimming
LTLED	LED Life-Time	50000	-	-	Hour	Ta = 25°C

**Note 1:** Calculator value for reference  $P_{LED} = V_F$  (Normal Distribution) \*  $I_F$  (Normal Distribution) / Efficiency

**Note 2:** The LED life-time define as the estimated time to 50% degradation of initial luminous.

**5.2.3 Backlight input signal characteristics**

Symbol	Parameter	Min	Typ	Max	Unit	Remark
Vcc	Input Voltage	10.8	12	13.2	Volt	
Ivcc	Input Current	-	2.3	-	A	VCC=12V, Ta=25 °C at 100%
PLED	Power Consumption	-	27.6	31.7	Watt	VCC=12V, Ta=25 °C at 100%
Inrush	Inrush Current	-	-	5	A	
VLED on/off	On Control Voltage	2	3.3	5	Volt	Back light on/off
	Off Control Voltage	0	-	0.6	Volt	
EPWM	PWM Dimming Frequency	200	-	20K	Hz	
	High Voltage	2	3.3	5	Volt	
	Low Voltage	0	-	0.6	Volt	
	Dimming Duty 200~5K	5	-	100	%	
	Dimming Duty 5K~20K	15	-	100	%	
I <sub>F</sub>	LED Forward Current	-	65	-	mA	Ta = 25°C (per string)

Note 1: Ta means ambient temperature of TFT-LCD module.

Note 2: If this module is driven at high ambient temperature & humidity condition. The operating life will be reduced.

Note 3: Operating life means brightness goes down to 50% initial brightness. Min. operating life time is estimated data.

**5.2.4 Backlight Driver Board Outline**

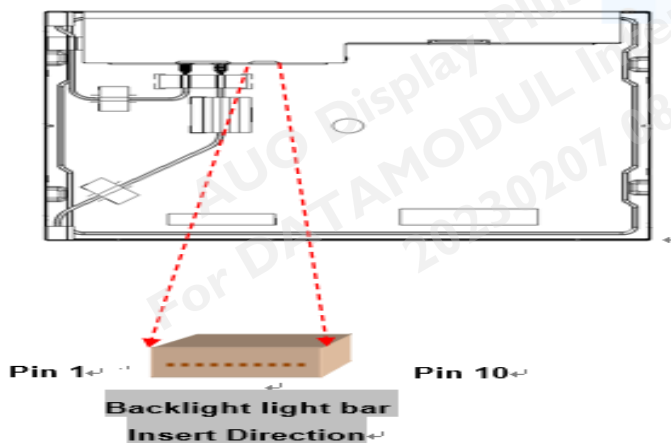

## 6. Signal Characteristic

### 6.1 Pixel Format Image

Following figure shows the relationship between input signal and LCD pixel format.

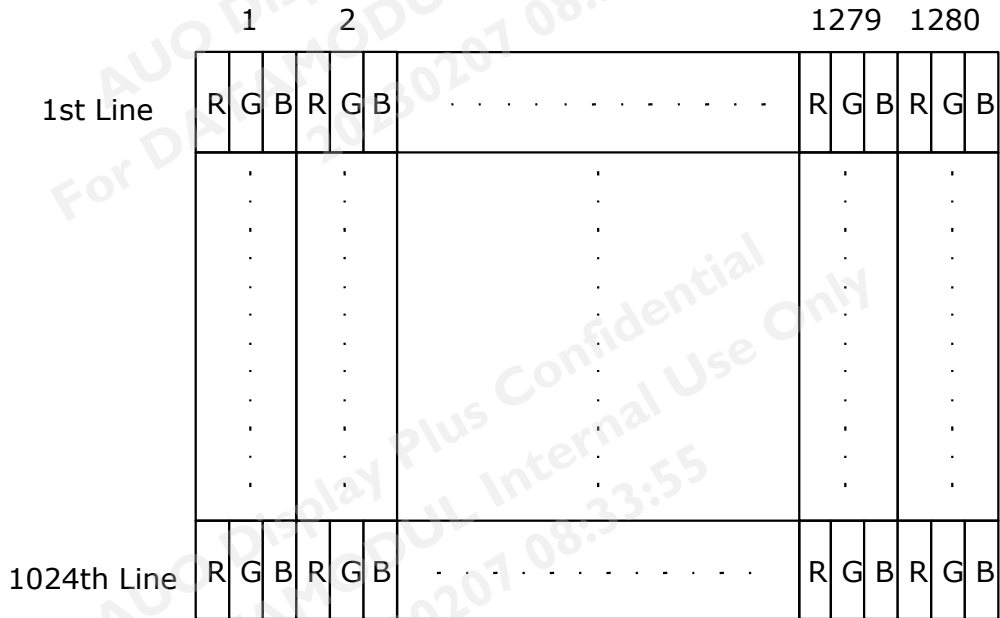

### 6.2 Scanning Direction

The following figures show the image seen from the front view. The arrow indicates the direction of scan.

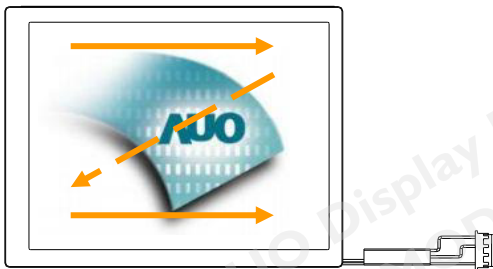

Fig. 1 Normal scan (Pin4, DPS = Low or NC)



## 6.3 Signal Description

The module uses a LVDS receiver embedded in AUO's ASIC. LVDS is a differential signal technology for LCD interface and a high-speed data transfer device.

### 6.3.1 TFT LCD Module: LVDS Connector

Connector Name / Designation	Signal Connector
Manufacturer	JAE
Connector Model Number	FI-XB30SSRLA-HF16-R3500
Adaptable Plug	FI-X30HL or Compatible FI-X30C-NPB or Compatible

The module using one LVDS receiver SN75LVDS82(Texas Instruments). LVDS is a differential signal technology for LCD interface and high speed data transfer device. LVDS transmitters shall be SN75LVDS83(negative edge sampling). The first LVDS port(RxOxxx) transmits odd pixels while the second LVDS port(RxExxx) transmits even pixels.

Pin no	Symbol	Function	Remark
1	RxOIN0-	Negative LVDS differential data input (Odd data)	
2	RxOIN0+	Positive LVDS differential data input (Odd data)	
3	RxOIN1-	Negative LVDS differential data input (Odd data)	
4	RxOIN1+	Positive LVDS differential data input (Odd data)	
5	RxOIN2-	Negative LVDS differential data input (Odd data, DSPTMG)	
6	RxOIN2+	Positive LVDS differential data input (Odd data, DSPTMG)	
7	GND	Power Ground	
8	RxOCLKIN-	Negative LVDS differential clock input (Odd clock)	
9	RxOCLKIN+	Positive LVDS differential clock input (Odd clock)	
10	RxOIN3-	Negative LVDS differential data input (Odd data)	
11	RxOIN3+	Positive LVDS differential data input (Odd data)	
12	RxEIN0-	Negative LVDS differential data input (Even data)	
13	RxEIN0+	Positive LVDS differential data input (Even data)	
14	GND	Power Ground	
15	RxEIN1-	Negative LVDS differential data input (Even data)	
16	RxEIN1+	Positive LVDS differential data input (Even data)	
17	GND	Power Ground	
18	RxEIN2-	Negative LVDS differential data input (Even data)	
19	RxEIN2+	Positive LVDS differential data input (Even data)	
20	RxECLKIN-	Negative LVDS differential clock input (Even clock)	
21	RxECLKIN+	Positive LVDS differential clock input (Even clock)	
22	RxEIN3-	Negative LVDS differential data input (Even data)	

## AUO Display+

23	RxEIN3+	Positive LVDS differential data input (Even data)	
24	GND	Power Ground	
25	GND	NC	
26	GND	NC	
27	GND	NC	
28	POWER	Power +5V	
29	POWER	Power +5V	
30	POWER	Power +5V	

Note 1: Input Signals shall be in low status when VDD is off.

Note 2: High stands for “3.3V”, Low stands for “0V”, NC means “No Connection”.

Note 3: RSV means “Reserved”.

Note 4: “Power Ground” stands for 0V.

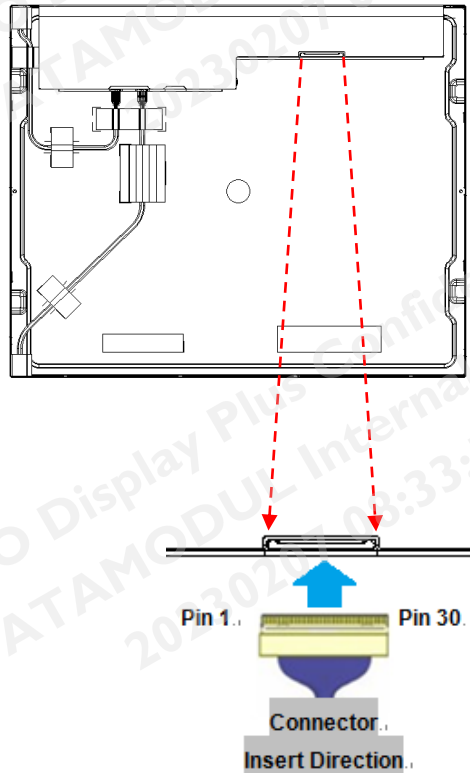

Note1: 30pin start from left side of connector. (Face up)

Note2: Input signals shall be low or High-impedance state when VDD is off.

**6.4 The Input Data Format**

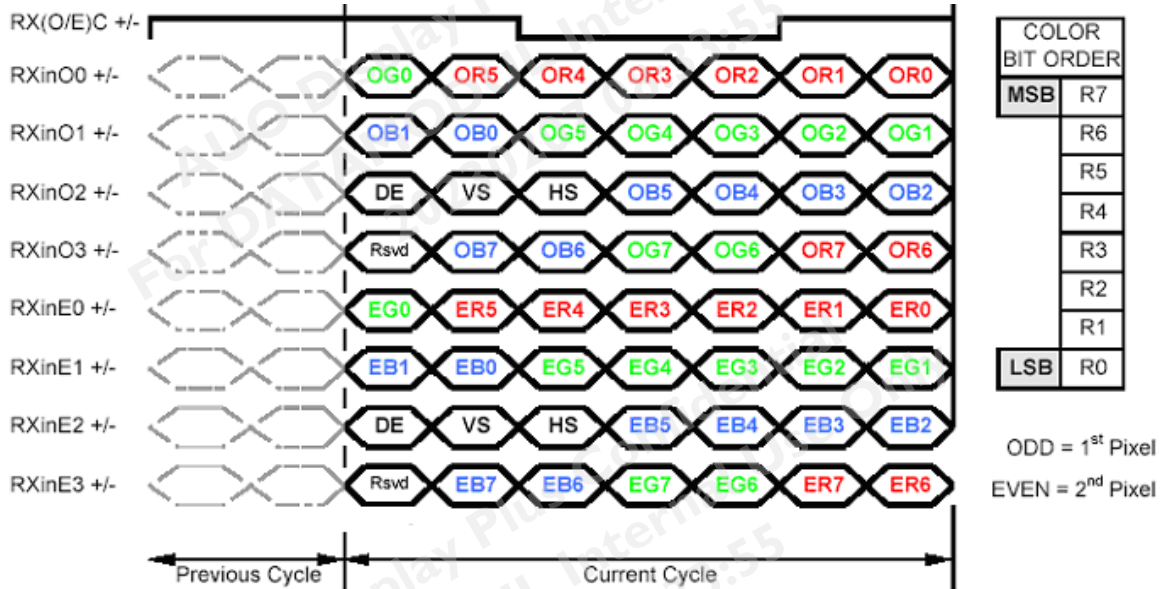

- Note1: Normally, DE, VS, HS on EVEN channel are not used.
- Note2: Please follow PSWG.
- Note3: 8-bit in

## 6.5 Interface Timing

### 6.5.1 Timing Characteristics

Signal		Symbol	Min.	Typ.	Max.	Unit
Clock	Period	T <sub>clk</sub>	22.2	18.52	14.81	ns
	Frequency	Freq.	44	54	67.5	MHz
Vertical Section	Period	T <sub>v</sub>	1032	1066	1150	T <sub>Line</sub>
	Active	T <sub>VD</sub>	1024	1024	1024	
	Blanking	T <sub>VB</sub>	8	42	126	
Horizontal Section	Period	T <sub>H</sub>	780	844	2047	T <sub>Clock</sub>
	Active	T <sub>HD</sub>	640	640	640	
	Blanking	T <sub>HB</sub>	140	204	-	
Frame Rate		F	49	60	75	Hz

Note : DE mode only.



6.5.2 Input Timing Diagram

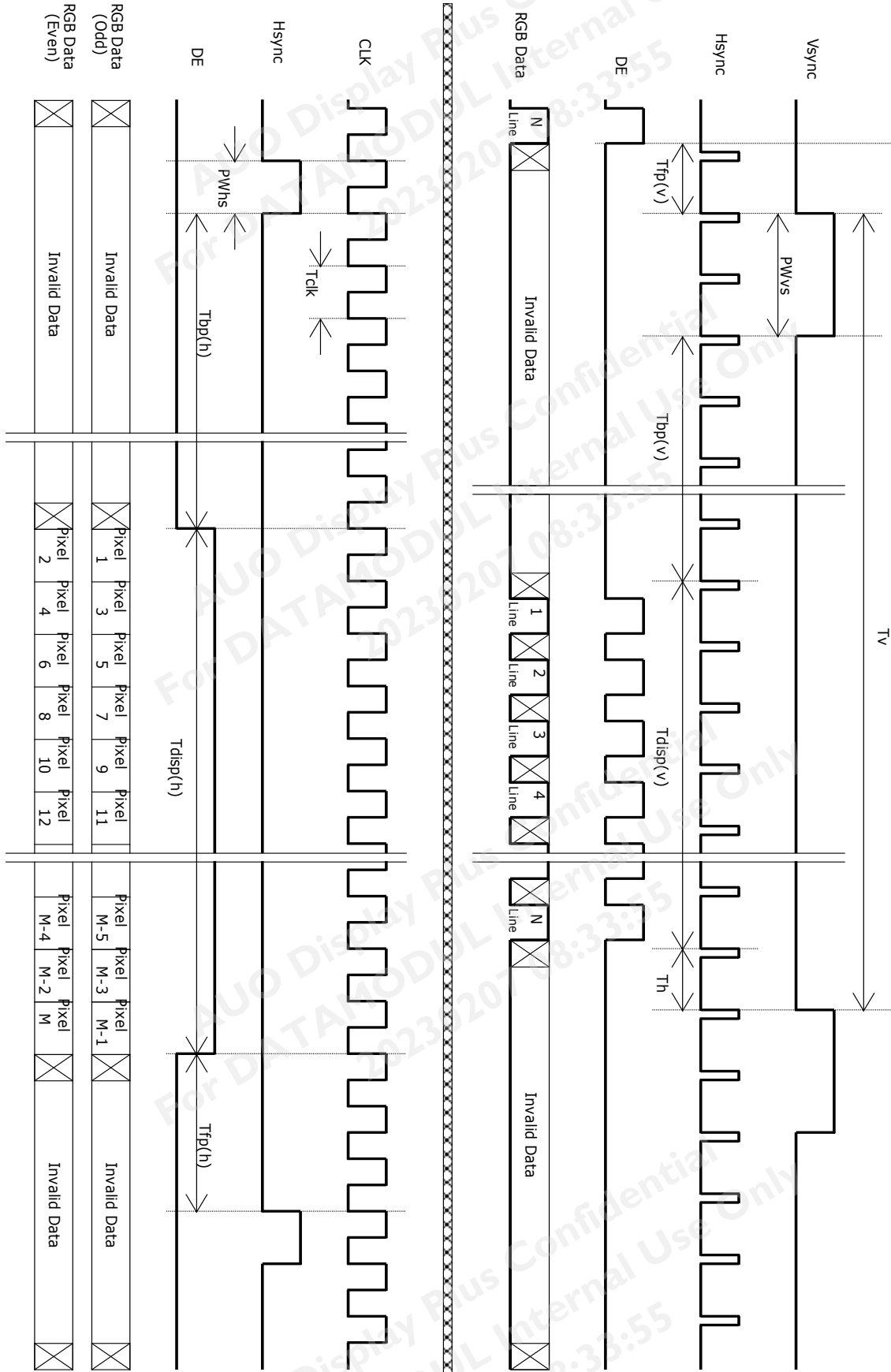

## 6.6 Power ON/OFF Sequence

VDD power and lamp on/off sequence are as follows. Interface signals are also shown in the chart. Signals from any system shall be Hi-Z state or low level when VDD is off.

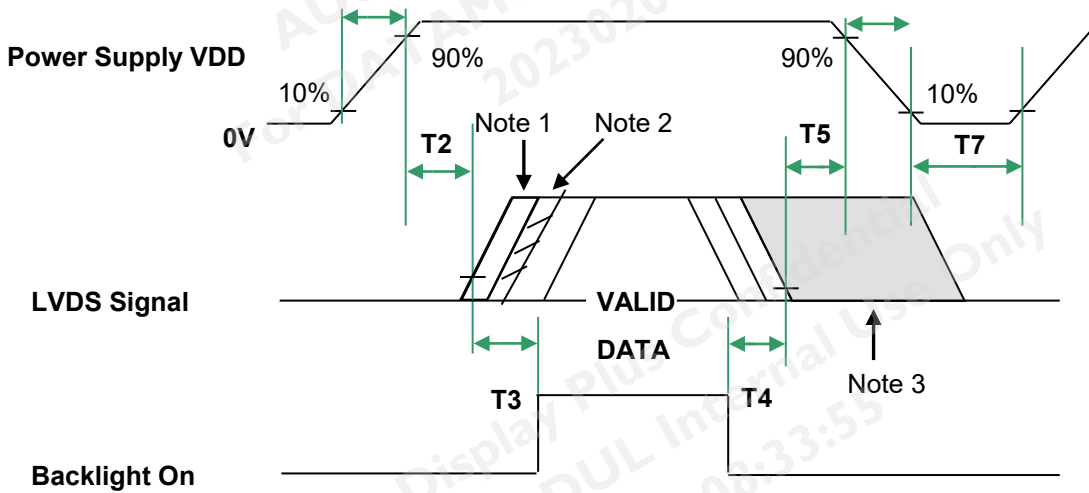

Note1: insert a white pattern 360ms

Note2: insert a black pattern

Note3: insert a white pattern after valid data and last until VDD falls to 10%.

Note4: when AC on/off, timing rule of logo power on/off is the same as above.

### Power ON/OFF sequence timing

Parameter	Value			Units
	Min.	Typ.	Max.	
T1	0.5	-	10	[ms]
T2	0	40	50	[ms]
T3	500	-	-	[ms]
T4	300	-	-	[ms]
T5	40	1500	-	[ms]
T6	-	-	-	[ms]
T7	1000	-	-	[ms]

The above on/off sequence should be applied to avoid abnormal function in the display. Please make sure to turn off the power when you plug the cable into the input connector or pull the cable out of the connector.

## 7. Reliability Test Criteria

Items	Required Condition	Note
Temperature Humidity Bias (THB)	Ta= 50°C, 80%RH, 240hours	
High Temperature Operation (HTO)	Ta= 70°C, 240hours	3
Low Temperature Operation (LTO)	Ta= -30°C, 240hours	
High Temperature Storage (HTS)	Ta= 70°C, 240hours	3
Low Temperature Storage (LTS)	Ta= -30°C, 240hours	
Vibration Test (Non-operation)	Acceleration: 1.5 Grms Wave: Random Frequency: 10 – 200 Hz Sweep: 30 Minutes each Axis (X, Y, Z)	
Shock Test (Non-operation)	Acceleration: 50 G Wave: Half-sine Active Time: 20 ms Direction: ±X, ±Y, ±Z (one time for each Axis) Axis)	
Thermal Shock Test (TST)	-20°C/30min, 60°C/30min, 50 cycles	
ESD (Electro-Static Discharge)	Contact Discharge: ± 8KV, 150pF(330Ω ) 1sec, 9 points, 25 times/ point.	1
	Air Discharge: ± 15KV, 150pF(330Ω ) 1sec, 9 points, 25 times/ point.	

Note1:

According to EN61000-4-2, ESD class B: Some performance degradation allowed. No data lost Self-recoverable. No hardware failures.

Note2:

- Water condensation is not allowed for each test items.
- Each test is done by new TFT-LCD module. Don't use the same TFT-LCD module repeatedly for reliability test.
- The reliability test is performed only to examine the TFT-LCD module capability.
- To inspect TFT-LCD module after reliability test, please store it at room temperature and room humidity for 24 hours at least in advance.
- Mura shall be ignored after high temperature reliability test.

Note 3 :

No function failure occurs at HTO and HTS test

## 8. Mechanical Characteristics

### 8.1 LCM Outline Dimension

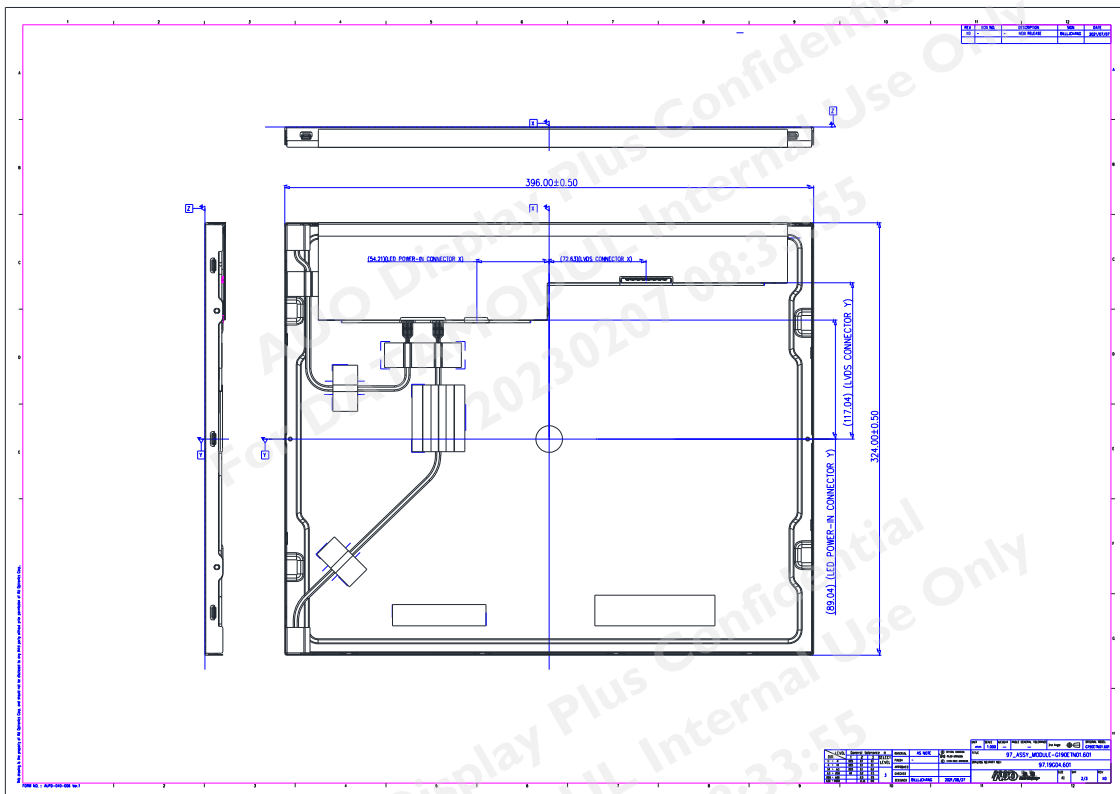
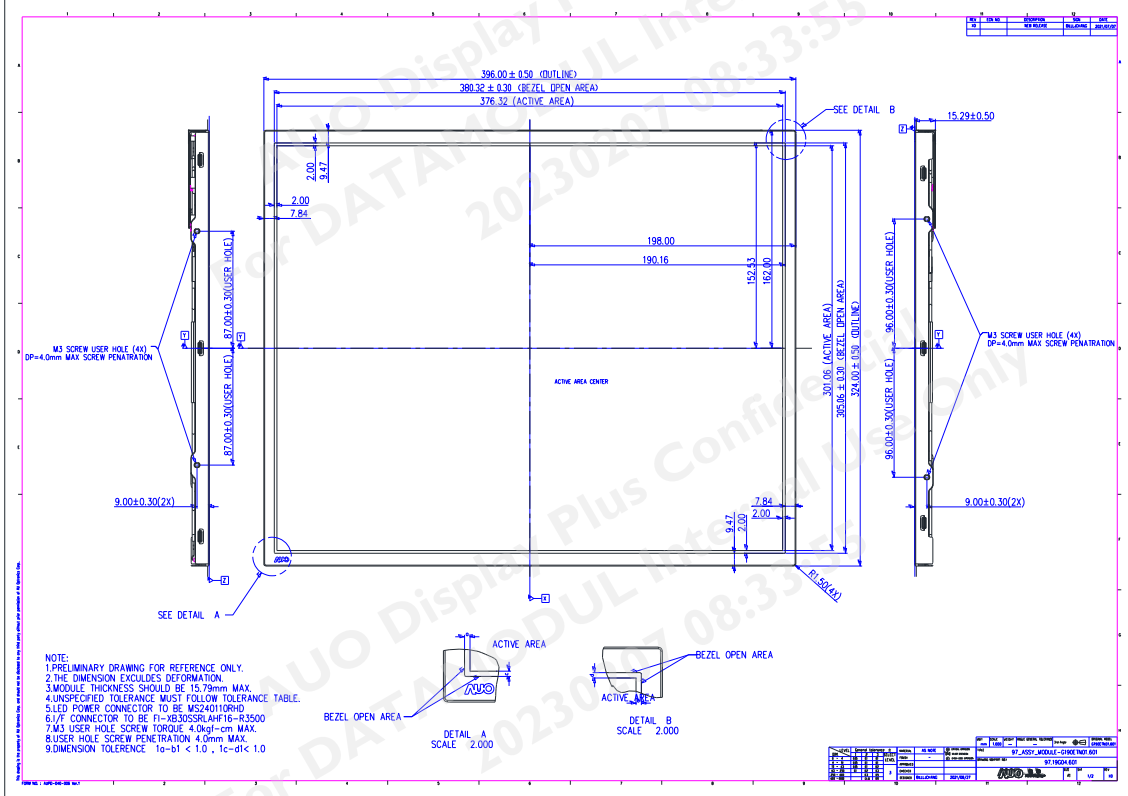

## 9. Label and Packaging

### 9.1 Shipping Label (on the rear side of TFT-LCD display)

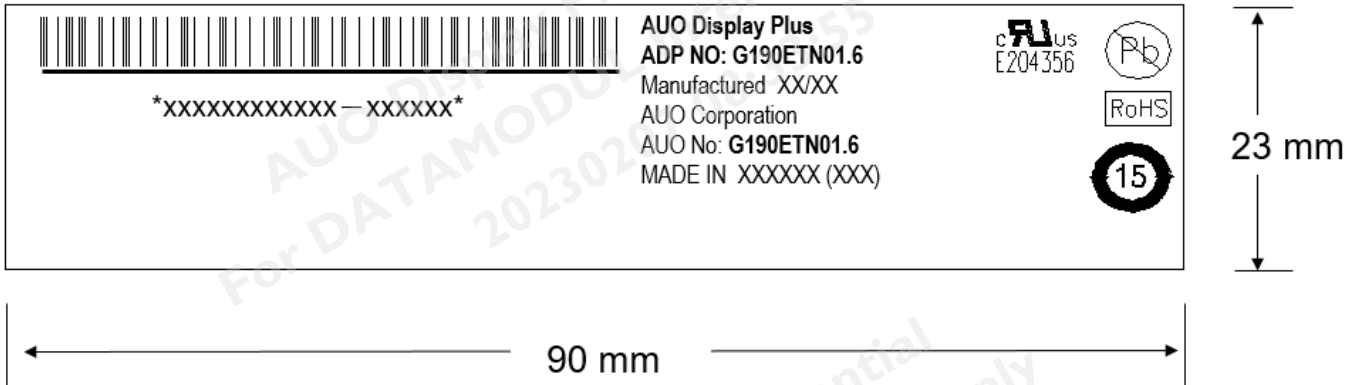

### 9.2 Carton Package

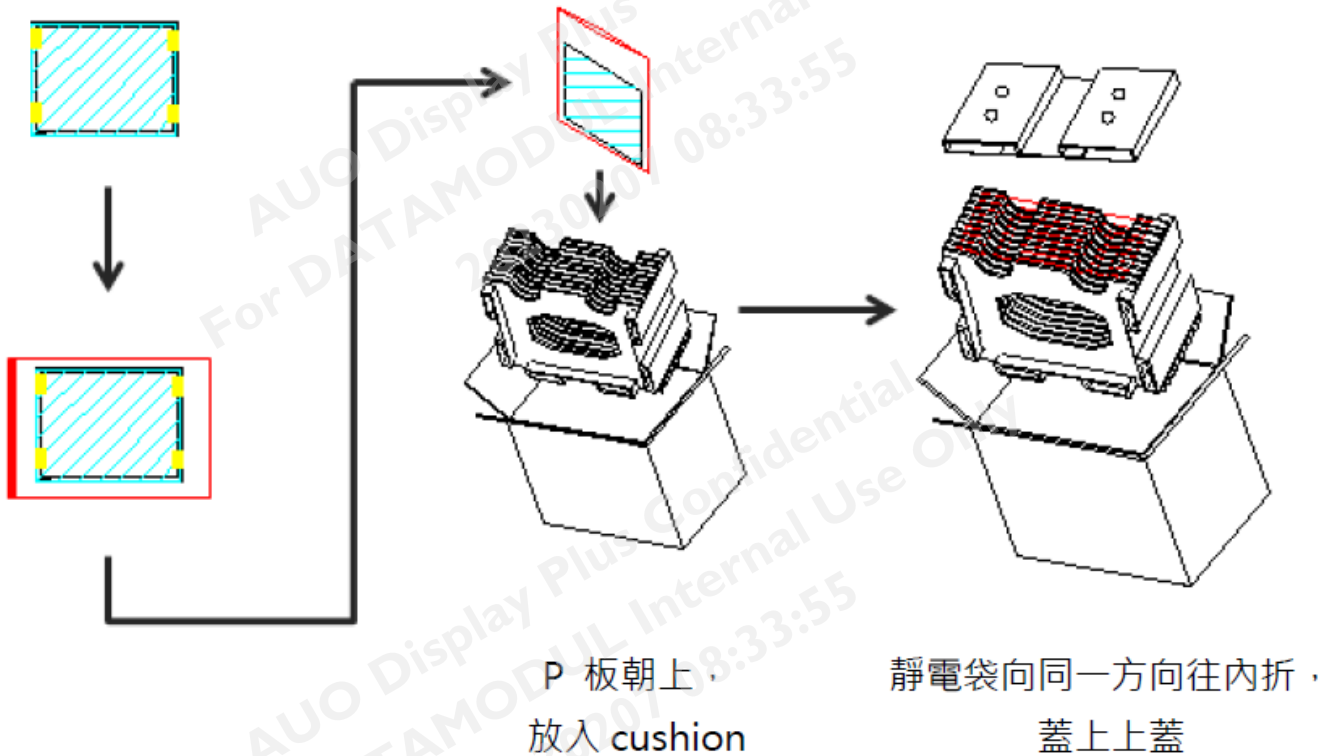

Max capacity : 7 modules per carton

Max weight: 14.0 kg per carton

Outside dimension of carton: 476 mm(L)\* 274 mm(W)\*414 mm(H)

Pallet size : 1150 mm \* 980 mm \* 132mm

### 9.3 Palletizing Sequence

Box stacked

Module by air : One pallet (2x4) x3 layers , one pallet put 24boxes , total 168pcs module



Module by sea : One pallet (2 \*4) \*3 layers + One pallet (2 \*4) \*1 layers , total 224 pcs module

Module by sea\_ HQ : One pallet (2 \*4) \*3 layers + One pallet (2 \*4) \*2 layers , Total 280 pcs module

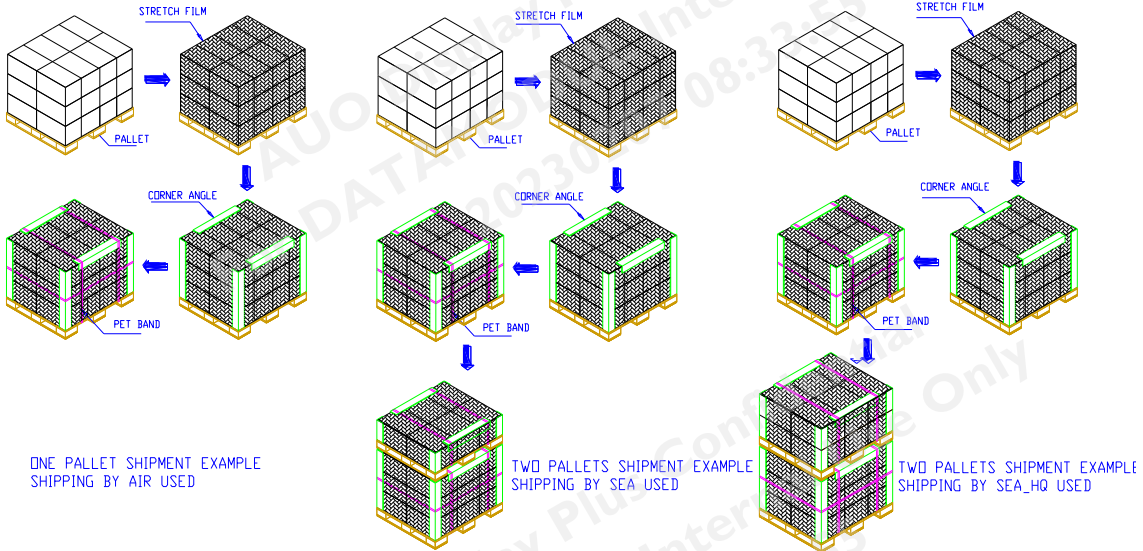



ALL TECHNOLOGIES. ALL COMPETENCIES. ONE SPECIALIST.

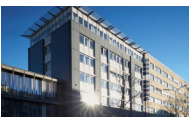

DATA MODUL AG  
Landsberger Straße 322 DE-  
80687 Munich  
Phone: +49-89-56017-0

DATA MODUL WEIKERSHEIM GMBH  
Lindenstraße 8  
DE-97990 Weikersheim Phone:  
+49-7934-101-0



More information and worldwide locations can be found at

[www.data-modul.com](http://www.data-modul.com)