



SPECIFICATION



G215HAN01.0

21.5" - FHD - LVDS

Version: 1.1

Date: 18.02.2019

Note: This specification is subject to change without prior notice



() Preliminary Specification
(V) Final Specification

Module	21.5" Color TFT-LCD
Model Name	G215HAN01.0

Customer	Date
_____	_____
Approved by	
_____	_____

Approved by	Date
<u>Floosie Chuang</u>	<u>2019/2/18</u>
Prepared by	
<u>Jet Huang</u>	<u>2019/2/18</u>

Note: This Specification is subject to change without notice.

Desktop Display Business Group /
AU Optronics corporation

Contents

1.0 Handling Precautions	4
2.0 General Description	5
2.1 Display Characteristics.....	5
2.2 Optical Characteristics	6
3.0 Functional Block Diagram	8
4.0 Absolute Maximum Ratings	9
4.1 TFT LCD Module.....	9
4.2 Absolute Ratings of Environment	10
5.0 Electrical characteristics	11
5.1 TFT LCD Module.....	11
5.1.1 Power Specification.....	11
5.1.2 Signal Electrical Characteristics	12
5.2 Backlight Unit	13
6.0 Signal Characteristic	14
6.1 Pixel Format Image	14
6.2 The input data format	15
6.3 Signal Description	16
6.4 Timing Characteristics	17
6.5 Timing diagram.....	19
6.6 Power ON/OFF Sequence	20
7.0 Connector & Pin Assignment	21
7.1 TFT LCD Module.....	21
7.2 LED Backlight Unit: LED Driver Connector	21
7.3 LED Driver Connector Pin Assignment	22
8.0 Reliability Test	23
9.0 Shipping Label & Packaging	24
9.1 Shipping Label	24
9.2 Packaging	25
9.3 Palletizing.....	26
10.0 Mechanical Characteristics	27
11 Safety	29
11.1 Sharp Edge Requirements	29
11.2 Materials.....	29
11.3 Capacitors	29
11.4 National Test Lab Requirement	29

Record of Revision

Version & Date	Page	Old description	New Description																																																																																																																																																																																																																																
0.0 / 2017/01/16			Preliminary Specification																																																																																																																																																																																																																																
0.1 / 2017/09/19	5	<p>2.1 Display Characteristics The following items are characteristics summary on the table under 25°C condition:</p> <table border="1"> <thead> <tr> <th>ITEMS</th> <th>Unit</th> <th>SPECIFICATIONS</th> </tr> </thead> <tbody> <tr><td>Screen Diagonal</td><td>[mm]</td><td>546.86 (21.5")</td></tr> <tr><td>Active Area</td><td>[mm]</td><td>476.064 (H) x 267.786 (V)</td></tr> <tr><td>Pixel Pitch</td><td>[mm]</td><td>1920(x3) x 1080</td></tr> <tr><td>Pixel Pitch</td><td>[um]</td><td>247.95 (per one triad) x 247.95</td></tr> <tr><td>Pixel Arrangement</td><td>-</td><td>R.G.B. Vertical Stripes</td></tr> <tr><td>Display Mode</td><td>-</td><td>AHVA Mode, Normally Black</td></tr> <tr><td>White Luminance (Center)</td><td>[cd/m²]</td><td>400 (Typ.)</td></tr> <tr><td>Contrast Ratio</td><td>-</td><td>1000 (Typ.)</td></tr> <tr><td>Optical Response Time</td><td>[msec]</td><td>22</td></tr> <tr><td>Nominal Input Voltage VDD</td><td>[Volt]</td><td>5 V (Typ.)</td></tr> <tr><td>Power Consumption (VDD line + LED line)</td><td>[Watt]</td><td>17.36W</td></tr> <tr><td>Weight</td><td>[Grams]</td><td>2100 (Typ.)</td></tr> <tr><td>Physical Size</td><td>[mm]</td><td>497.6(H) x 292.2(V) x 17.7 (D) Typ.</td></tr> <tr><td>Electrical Interface</td><td>-</td><td>Dual LVDS</td></tr> <tr><td>Support Color</td><td>-</td><td>16.7M colors, True 8 bit</td></tr> <tr><td>Surface Treatment</td><td>-</td><td>Anti-Glare, 3H</td></tr> <tr><td>RoHS Compliance</td><td>-</td><td>RoHS Compliance</td></tr> <tr><td>Temperature Range (Operating)</td><td>[°C]</td><td>0~50</td></tr> <tr><td>Storage (Shipping)</td><td>[°C]</td><td>-20~50</td></tr> </tbody> </table>	ITEMS	Unit	SPECIFICATIONS	Screen Diagonal	[mm]	546.86 (21.5")	Active Area	[mm]	476.064 (H) x 267.786 (V)	Pixel Pitch	[mm]	1920(x3) x 1080	Pixel Pitch	[um]	247.95 (per one triad) x 247.95	Pixel Arrangement	-	R.G.B. Vertical Stripes	Display Mode	-	AHVA Mode, Normally Black	White Luminance (Center)	[cd/m ²]	400 (Typ.)	Contrast Ratio	-	1000 (Typ.)	Optical Response Time	[msec]	22	Nominal Input Voltage VDD	[Volt]	5 V (Typ.)	Power Consumption (VDD line + LED line)	[Watt]	17.36W	Weight	[Grams]	2100 (Typ.)	Physical Size	[mm]	497.6(H) x 292.2(V) x 17.7 (D) Typ.	Electrical Interface	-	Dual LVDS	Support Color	-	16.7M colors, True 8 bit	Surface Treatment	-	Anti-Glare, 3H	RoHS Compliance	-	RoHS Compliance	Temperature Range (Operating)	[°C]	0~50	Storage (Shipping)	[°C]	-20~50	<p>2.1 Display Characteristics The following items are characteristics summary on the table under 25°C condition:</p> <table border="1"> <thead> <tr> <th>ITEMS</th> <th>Unit</th> <th>SPECIFICATIONS</th> </tr> </thead> <tbody> <tr><td>Screen Diagonal</td><td>[mm]</td><td>546.86 (21.5")</td></tr> <tr><td>Active Area</td><td>[mm]</td><td>476.064 (H) x 267.786 (V)</td></tr> <tr><td>Pixel Pitch</td><td>[um]</td><td>247.95 (per one triad) x 247.95</td></tr> <tr><td>Pixel Arrangement</td><td>-</td><td>R.G.B. Vertical Stripes</td></tr> <tr><td>Display Mode</td><td>-</td><td>AHVA Mode, Normally Black</td></tr> <tr><td>White Luminance (Center)</td><td>[cd/m²]</td><td>400 (Typ.)</td></tr> <tr><td>Contrast Ratio</td><td>-</td><td>1000 (Typ.)</td></tr> <tr><td>Optical Response Time</td><td>[msec]</td><td>22</td></tr> <tr><td>Nominal Input Voltage VDD</td><td>[Volt]</td><td>5 V (Typ.)</td></tr> <tr><td>Power Consumption (VDD line + LED line)</td><td>[Watt]</td><td>17.36W</td></tr> <tr><td>Weight</td><td>[Grams]</td><td>2100 (Typ.)</td></tr> <tr><td>Physical Size</td><td>[mm]</td><td>497.6(H) x 292.2(V) x 17.7 (D) Typ.</td></tr> <tr><td>Electrical Interface</td><td>-</td><td>Dual LVDS</td></tr> <tr><td>Support Color</td><td>-</td><td>16.7M colors, True 8 bit</td></tr> <tr><td>Surface Treatment</td><td>-</td><td>Anti-Glare, 3H</td></tr> <tr><td>RoHS Compliance</td><td>-</td><td>RoHS Compliance</td></tr> <tr><td>Temperature Range (Operating)</td><td>[°C]</td><td>0~50</td></tr> <tr><td>Storage (Shipping)</td><td>[°C]</td><td>-20~60</td></tr> </tbody> </table>	ITEMS	Unit	SPECIFICATIONS	Screen Diagonal	[mm]	546.86 (21.5")	Active Area	[mm]	476.064 (H) x 267.786 (V)	Pixel Pitch	[um]	247.95 (per one triad) x 247.95	Pixel Arrangement	-	R.G.B. Vertical Stripes	Display Mode	-	AHVA Mode, Normally Black	White Luminance (Center)	[cd/m ²]	400 (Typ.)	Contrast Ratio	-	1000 (Typ.)	Optical Response Time	[msec]	22	Nominal Input Voltage VDD	[Volt]	5 V (Typ.)	Power Consumption (VDD line + LED line)	[Watt]	17.36W	Weight	[Grams]	2100 (Typ.)	Physical Size	[mm]	497.6(H) x 292.2(V) x 17.7 (D) Typ.	Electrical Interface	-	Dual LVDS	Support Color	-	16.7M colors, True 8 bit	Surface Treatment	-	Anti-Glare, 3H	RoHS Compliance	-	RoHS Compliance	Temperature Range (Operating)	[°C]	0~50	Storage (Shipping)	[°C]	-20~60																																																																																																											
ITEMS	Unit	SPECIFICATIONS																																																																																																																																																																																																																																	
Screen Diagonal	[mm]	546.86 (21.5")																																																																																																																																																																																																																																	
Active Area	[mm]	476.064 (H) x 267.786 (V)																																																																																																																																																																																																																																	
Pixel Pitch	[mm]	1920(x3) x 1080																																																																																																																																																																																																																																	
Pixel Pitch	[um]	247.95 (per one triad) x 247.95																																																																																																																																																																																																																																	
Pixel Arrangement	-	R.G.B. Vertical Stripes																																																																																																																																																																																																																																	
Display Mode	-	AHVA Mode, Normally Black																																																																																																																																																																																																																																	
White Luminance (Center)	[cd/m ²]	400 (Typ.)																																																																																																																																																																																																																																	
Contrast Ratio	-	1000 (Typ.)																																																																																																																																																																																																																																	
Optical Response Time	[msec]	22																																																																																																																																																																																																																																	
Nominal Input Voltage VDD	[Volt]	5 V (Typ.)																																																																																																																																																																																																																																	
Power Consumption (VDD line + LED line)	[Watt]	17.36W																																																																																																																																																																																																																																	
Weight	[Grams]	2100 (Typ.)																																																																																																																																																																																																																																	
Physical Size	[mm]	497.6(H) x 292.2(V) x 17.7 (D) Typ.																																																																																																																																																																																																																																	
Electrical Interface	-	Dual LVDS																																																																																																																																																																																																																																	
Support Color	-	16.7M colors, True 8 bit																																																																																																																																																																																																																																	
Surface Treatment	-	Anti-Glare, 3H																																																																																																																																																																																																																																	
RoHS Compliance	-	RoHS Compliance																																																																																																																																																																																																																																	
Temperature Range (Operating)	[°C]	0~50																																																																																																																																																																																																																																	
Storage (Shipping)	[°C]	-20~50																																																																																																																																																																																																																																	
ITEMS	Unit	SPECIFICATIONS																																																																																																																																																																																																																																	
Screen Diagonal	[mm]	546.86 (21.5")																																																																																																																																																																																																																																	
Active Area	[mm]	476.064 (H) x 267.786 (V)																																																																																																																																																																																																																																	
Pixel Pitch	[um]	247.95 (per one triad) x 247.95																																																																																																																																																																																																																																	
Pixel Arrangement	-	R.G.B. Vertical Stripes																																																																																																																																																																																																																																	
Display Mode	-	AHVA Mode, Normally Black																																																																																																																																																																																																																																	
White Luminance (Center)	[cd/m ²]	400 (Typ.)																																																																																																																																																																																																																																	
Contrast Ratio	-	1000 (Typ.)																																																																																																																																																																																																																																	
Optical Response Time	[msec]	22																																																																																																																																																																																																																																	
Nominal Input Voltage VDD	[Volt]	5 V (Typ.)																																																																																																																																																																																																																																	
Power Consumption (VDD line + LED line)	[Watt]	17.36W																																																																																																																																																																																																																																	
Weight	[Grams]	2100 (Typ.)																																																																																																																																																																																																																																	
Physical Size	[mm]	497.6(H) x 292.2(V) x 17.7 (D) Typ.																																																																																																																																																																																																																																	
Electrical Interface	-	Dual LVDS																																																																																																																																																																																																																																	
Support Color	-	16.7M colors, True 8 bit																																																																																																																																																																																																																																	
Surface Treatment	-	Anti-Glare, 3H																																																																																																																																																																																																																																	
RoHS Compliance	-	RoHS Compliance																																																																																																																																																																																																																																	
Temperature Range (Operating)	[°C]	0~50																																																																																																																																																																																																																																	
Storage (Shipping)	[°C]	-20~60																																																																																																																																																																																																																																	
0.1 / 2017/09/19	6	<p>2.2 Optical Characteristics The optical characteristics are measured under stable conditions at 25°C.</p> <table border="1"> <thead> <tr> <th>Item</th> <th>Unit</th> <th>Conditions</th> <th>Min.</th> <th>Typ.</th> <th>Max.</th> <th>Note</th> </tr> </thead> <tbody> <tr> <td rowspan="2">Viewing Angle</td> <td rowspan="2">[degree]</td> <td>Horizontal (Right), CR > 10</td> <td>-</td> <td>89</td> <td>-</td> <td>2</td> </tr> <tr> <td>Vertical (Up), CR > 10</td> <td>-</td> <td>89</td> <td>-</td> <td>2</td> </tr> <tr> <td rowspan="2">Contrast Ratio</td> <td rowspan="2">-</td> <td>Normal Direction</td> <td>800</td> <td>1000</td> <td>-</td> <td>3</td> </tr> <tr> <td>Raising + Falling</td> <td>-</td> <td>TBD</td> <td>-</td> <td>4</td> </tr> <tr> <td rowspan="2">Response Time</td> <td rowspan="2">[msec]</td> <td>Raising + Falling</td> <td>-</td> <td>14</td> <td>25</td> <td>4</td> </tr> <tr> <td>Red x, Red y</td> <td>-</td> <td>TBD</td> <td>-</td> <td>5</td> </tr> <tr> <td rowspan="4">Color / Chromaticity Coordinates (CIE)</td> <td rowspan="4">-</td> <td>Green x, Green y</td> <td>-</td> <td>TBD</td> <td>-</td> <td>5</td> </tr> <tr> <td>Blue x, Blue y</td> <td>-</td> <td>TBD</td> <td>-</td> <td>5</td> </tr> <tr> <td>White x, White y</td> <td>0.283</td> <td>0.313</td> <td>0.343</td> <td>-</td> <td>5</td> </tr> <tr> <td>White x, White y</td> <td>0.299</td> <td>0.329</td> <td>0.359</td> <td>-</td> <td>5</td> </tr> <tr> <td>Central Luminance</td> <td>[cd/m²]</td> <td>-</td> <td>320</td> <td>400</td> <td>-</td> <td>6</td> </tr> <tr> <td>Luminance Uniformity</td> <td>[%]</td> <td>-</td> <td>80</td> <td>85</td> <td>-</td> <td>7</td> </tr> <tr> <td>Color Gamut</td> <td>[%]</td> <td>-</td> <td>-</td> <td>72</td> <td>-</td> <td>7</td> </tr> </tbody> </table>	Item	Unit	Conditions	Min.	Typ.	Max.	Note	Viewing Angle	[degree]	Horizontal (Right), CR > 10	-	89	-	2	Vertical (Up), CR > 10	-	89	-	2	Contrast Ratio	-	Normal Direction	800	1000	-	3	Raising + Falling	-	TBD	-	4	Response Time	[msec]	Raising + Falling	-	14	25	4	Red x, Red y	-	TBD	-	5	Color / Chromaticity Coordinates (CIE)	-	Green x, Green y	-	TBD	-	5	Blue x, Blue y	-	TBD	-	5	White x, White y	0.283	0.313	0.343	-	5	White x, White y	0.299	0.329	0.359	-	5	Central Luminance	[cd/m ²]	-	320	400	-	6	Luminance Uniformity	[%]	-	80	85	-	7	Color Gamut	[%]	-	-	72	-	7	<p>2.2 Optical Characteristics The optical characteristics are measured under stable conditions at 25°C.</p> <table border="1"> <thead> <tr> <th>Item</th> <th>Unit</th> <th>Conditions</th> <th>Min.</th> <th>Typ.</th> <th>Max.</th> <th>Note</th> </tr> </thead> <tbody> <tr> <td rowspan="2">Viewing Angle</td> <td rowspan="2">[degree]</td> <td>Horizontal (Right), CR > 10</td> <td>-</td> <td>89</td> <td>-</td> <td>2</td> </tr> <tr> <td>Vertical (Up), CR > 10</td> <td>-</td> <td>89</td> <td>-</td> <td>2</td> </tr> <tr> <td rowspan="2">Contrast Ratio</td> <td rowspan="2">-</td> <td>Normal Direction</td> <td>800</td> <td>1000</td> <td>-</td> <td>3</td> </tr> <tr> <td>Raising + Falling</td> <td>-</td> <td>TBD</td> <td>-</td> <td>4</td> </tr> <tr> <td rowspan="2">Response Time</td> <td rowspan="2">[msec]</td> <td>Raising + Falling</td> <td>-</td> <td>12</td> <td>22</td> <td>4</td> </tr> <tr> <td>Red x, Red y</td> <td>0.609</td> <td>0.639</td> <td>0.669</td> <td>-</td> <td>5</td> </tr> <tr> <td rowspan="4">Color / Chromaticity Coordinates (CIE)</td> <td rowspan="4">-</td> <td>Green x, Green y</td> <td>0.282</td> <td>0.312</td> <td>0.342</td> <td>-</td> <td>5</td> </tr> <tr> <td>Blue x, Blue y</td> <td>0.295</td> <td>0.325</td> <td>0.355</td> <td>-</td> <td>5</td> </tr> <tr> <td>White x, White y</td> <td>0.283</td> <td>0.313</td> <td>0.343</td> <td>-</td> <td>5</td> </tr> <tr> <td>White x, White y</td> <td>0.299</td> <td>0.329</td> <td>0.359</td> <td>-</td> <td>5</td> </tr> <tr> <td>Central Luminance</td> <td>[cd/m²]</td> <td>-</td> <td>320</td> <td>400</td> <td>-</td> <td>6</td> </tr> <tr> <td>Luminance Uniformity</td> <td>[%]</td> <td>-</td> <td>80</td> <td>85</td> <td>-</td> <td>7</td> </tr> <tr> <td>Color Gamut</td> <td>[%]</td> <td>-</td> <td>-</td> <td>72</td> <td>-</td> <td>7</td> </tr> </tbody> </table>	Item	Unit	Conditions	Min.	Typ.	Max.	Note	Viewing Angle	[degree]	Horizontal (Right), CR > 10	-	89	-	2	Vertical (Up), CR > 10	-	89	-	2	Contrast Ratio	-	Normal Direction	800	1000	-	3	Raising + Falling	-	TBD	-	4	Response Time	[msec]	Raising + Falling	-	12	22	4	Red x, Red y	0.609	0.639	0.669	-	5	Color / Chromaticity Coordinates (CIE)	-	Green x, Green y	0.282	0.312	0.342	-	5	Blue x, Blue y	0.295	0.325	0.355	-	5	White x, White y	0.283	0.313	0.343	-	5	White x, White y	0.299	0.329	0.359	-	5	Central Luminance	[cd/m ²]	-	320	400	-	6	Luminance Uniformity	[%]	-	80	85	-	7	Color Gamut	[%]	-	-	72	-	7																																													
Item	Unit	Conditions	Min.	Typ.	Max.	Note																																																																																																																																																																																																																													
Viewing Angle	[degree]	Horizontal (Right), CR > 10	-	89	-	2																																																																																																																																																																																																																													
		Vertical (Up), CR > 10	-	89	-	2																																																																																																																																																																																																																													
Contrast Ratio	-	Normal Direction	800	1000	-	3																																																																																																																																																																																																																													
		Raising + Falling	-	TBD	-	4																																																																																																																																																																																																																													
Response Time	[msec]	Raising + Falling	-	14	25	4																																																																																																																																																																																																																													
		Red x, Red y	-	TBD	-	5																																																																																																																																																																																																																													
Color / Chromaticity Coordinates (CIE)	-	Green x, Green y	-	TBD	-	5																																																																																																																																																																																																																													
		Blue x, Blue y	-	TBD	-	5																																																																																																																																																																																																																													
		White x, White y	0.283	0.313	0.343	-	5																																																																																																																																																																																																																												
		White x, White y	0.299	0.329	0.359	-	5																																																																																																																																																																																																																												
Central Luminance	[cd/m ²]	-	320	400	-	6																																																																																																																																																																																																																													
Luminance Uniformity	[%]	-	80	85	-	7																																																																																																																																																																																																																													
Color Gamut	[%]	-	-	72	-	7																																																																																																																																																																																																																													
Item	Unit	Conditions	Min.	Typ.	Max.	Note																																																																																																																																																																																																																													
Viewing Angle	[degree]	Horizontal (Right), CR > 10	-	89	-	2																																																																																																																																																																																																																													
		Vertical (Up), CR > 10	-	89	-	2																																																																																																																																																																																																																													
Contrast Ratio	-	Normal Direction	800	1000	-	3																																																																																																																																																																																																																													
		Raising + Falling	-	TBD	-	4																																																																																																																																																																																																																													
Response Time	[msec]	Raising + Falling	-	12	22	4																																																																																																																																																																																																																													
		Red x, Red y	0.609	0.639	0.669	-	5																																																																																																																																																																																																																												
Color / Chromaticity Coordinates (CIE)	-	Green x, Green y	0.282	0.312	0.342	-	5																																																																																																																																																																																																																												
		Blue x, Blue y	0.295	0.325	0.355	-	5																																																																																																																																																																																																																												
		White x, White y	0.283	0.313	0.343	-	5																																																																																																																																																																																																																												
		White x, White y	0.299	0.329	0.359	-	5																																																																																																																																																																																																																												
Central Luminance	[cd/m ²]	-	320	400	-	6																																																																																																																																																																																																																													
Luminance Uniformity	[%]	-	80	85	-	7																																																																																																																																																																																																																													
Color Gamut	[%]	-	-	72	-	7																																																																																																																																																																																																																													
1.0 / 2017/12/22	10	<p>4.2 Absolute Ratings of Environment</p> <table border="1"> <thead> <tr> <th>Item</th> <th>Symbol</th> <th>Min.</th> <th>Max.</th> <th>Unit</th> <th>Conditions</th> </tr> </thead> <tbody> <tr> <td>Operating Temperature</td> <td>TOP</td> <td>0</td> <td>50</td> <td>[°C]</td> <td rowspan="5">Note 3 & 4</td> </tr> <tr> <td>Operation Humidity</td> <td>HOP</td> <td>5</td> <td>90</td> <td>[%RH]</td> </tr> <tr> <td>Storage Temperature</td> <td>TST</td> <td>-20</td> <td>60</td> <td>[°C]</td> </tr> <tr> <td>Storage Humidity</td> <td>HST</td> <td>5</td> <td>95</td> <td>[%RH]</td> </tr> </tbody> </table>	Item	Symbol	Min.	Max.	Unit	Conditions	Operating Temperature	TOP	0	50	[°C]	Note 3 & 4	Operation Humidity	HOP	5	90	[%RH]	Storage Temperature	TST	-20	60	[°C]	Storage Humidity	HST	5	95	[%RH]	<p>4.2 Absolute Ratings of Environment</p> <table border="1"> <thead> <tr> <th>Item</th> <th>Symbol</th> <th>Min.</th> <th>Max.</th> <th>Unit</th> <th>Conditions</th> </tr> </thead> <tbody> <tr> <td>Operating Temperature</td> <td>TOP</td> <td>0</td> <td>50</td> <td>[°C]</td> <td rowspan="5">Note 3 & 4</td> </tr> <tr> <td>Operation Humidity</td> <td>HOP</td> <td>5</td> <td>90</td> <td>[%RH]</td> </tr> <tr> <td>Storage Temperature</td> <td>TST</td> <td>-20</td> <td>60</td> <td>[°C]</td> </tr> <tr> <td>Storage Humidity</td> <td>HST</td> <td>5</td> <td>90</td> <td>[%RH]</td> </tr> </tbody> </table>	Item	Symbol	Min.	Max.	Unit	Conditions	Operating Temperature	TOP	0	50	[°C]	Note 3 & 4	Operation Humidity	HOP	5	90	[%RH]	Storage Temperature	TST	-20	60	[°C]	Storage Humidity	HST	5	90	[%RH]																																																																																																																																																																										
Item	Symbol	Min.	Max.	Unit	Conditions																																																																																																																																																																																																																														
Operating Temperature	TOP	0	50	[°C]	Note 3 & 4																																																																																																																																																																																																																														
Operation Humidity	HOP	5	90	[%RH]																																																																																																																																																																																																																															
Storage Temperature	TST	-20	60	[°C]																																																																																																																																																																																																																															
Storage Humidity	HST	5	95	[%RH]																																																																																																																																																																																																																															
Item	Symbol	Min.	Max.	Unit		Conditions																																																																																																																																																																																																																													
Operating Temperature	TOP	0	50	[°C]	Note 3 & 4																																																																																																																																																																																																																														
Operation Humidity	HOP	5	90	[%RH]																																																																																																																																																																																																																															
Storage Temperature	TST	-20	60	[°C]																																																																																																																																																																																																																															
Storage Humidity	HST	5	90	[%RH]																																																																																																																																																																																																																															
	23	<p>*8.0 Reliability Test Environment test conditions are listed as following table</p> <table border="1"> <thead> <tr> <th>Items</th> <th>Required Condition</th> <th>Note</th> </tr> </thead> <tbody> <tr> <td>Temperature Humidity Bias (THB)</td> <td>Ta=50°C, 80%RH, 300hours</td> <td></td> </tr> <tr> <td>High Temperature Operation (HTO)</td> <td>Ta=50°C, 300hours</td> <td></td> </tr> <tr> <td>Low Temperature Operation (LTO)</td> <td>Ta=0°C, 300hours</td> <td></td> </tr> <tr> <td>High Temperature Storage (HTS)</td> <td>Ta=50°C, 300hours</td> <td></td> </tr> <tr> <td>Low Temperature Storage (LTS)</td> <td>Ta=-20°C, 300hours</td> <td></td> </tr> <tr> <td>Vibration Test (Non-operation)</td> <td>Acceleration: 1.5 Gms Wave: Random Frequency: 10~200 Hz Sweep: 30 Minutes each Axis (X, Y, Z)</td> <td></td> </tr> <tr> <td>Shock Test (Non-operation)</td> <td>Acceleration: 50 G Wave: Half-sine Active Time: 20 ms Direction: X, Y, Z (one time for each Axis)</td> <td></td> </tr> <tr> <td>Drop Test</td> <td>Height: 61 cm, package test</td> <td></td> </tr> <tr> <td>Thermal Shock Test (TST)</td> <td>-20°C/30min, 50°C/30min, 100 cycles</td> <td>1</td> </tr> <tr> <td>On/Off Test</td> <td>On/10sec, Off/10sec, 30,000 cycles</td> <td></td> </tr> <tr> <td>ESD (Electro Static Discharge)</td> <td>Contact Discharge: ±8KV, 150pF(3300) 1sec, 8 points, 25 times/point Air Discharge: ±15KV, 150pF(3300) 1sec, 8 points, 25 times/point</td> <td>2</td> </tr> <tr> <td>Altitude Test</td> <td>Operation: 10,000 ft. Non-Operation: 30,000 ft.</td> <td></td> </tr> </tbody> </table>	Items	Required Condition		Note	Temperature Humidity Bias (THB)	Ta=50°C, 80%RH, 300hours		High Temperature Operation (HTO)	Ta=50°C, 300hours		Low Temperature Operation (LTO)	Ta=0°C, 300hours		High Temperature Storage (HTS)	Ta=50°C, 300hours		Low Temperature Storage (LTS)	Ta=-20°C, 300hours		Vibration Test (Non-operation)	Acceleration: 1.5 Gms Wave: Random Frequency: 10~200 Hz Sweep: 30 Minutes each Axis (X, Y, Z)		Shock Test (Non-operation)	Acceleration: 50 G Wave: Half-sine Active Time: 20 ms Direction: X, Y, Z (one time for each Axis)		Drop Test	Height: 61 cm, package test		Thermal Shock Test (TST)	-20°C/30min, 50°C/30min, 100 cycles	1	On/Off Test	On/10sec, Off/10sec, 30,000 cycles		ESD (Electro Static Discharge)	Contact Discharge: ±8KV, 150pF(3300) 1sec, 8 points, 25 times/point Air Discharge: ±15KV, 150pF(3300) 1sec, 8 points, 25 times/point	2	Altitude Test	Operation: 10,000 ft. Non-Operation: 30,000 ft.		<p>*8.0 Reliability Test Environment test conditions are listed as following table</p> <table border="1"> <thead> <tr> <th>Items</th> <th>Required Condition</th> <th>Note</th> </tr> </thead> <tbody> <tr> <td>Temperature Humidity Bias (THB)</td> <td>Ta=50°C, 80%RH, 300hours</td> <td></td> </tr> <tr> <td>High Temperature Operation (HTO)</td> <td>Ta=50°C, 300hours</td> <td></td> </tr> <tr> <td>Low Temperature Operation (LTO)</td> <td>Ta=0°C, 300hours</td> <td></td> </tr> <tr> <td>High Temperature Storage (HTS)</td> <td>Ta=50°C, 300hours</td> <td></td> </tr> <tr> <td>Low Temperature Storage (LTS)</td> <td>Ta=-20°C, 300hours</td> <td></td> </tr> <tr> <td>Vibration Test (Non-operation)</td> <td>Acceleration: 1.5 Gms Wave: Random Frequency: 10~200 Hz Sweep: 30 Minutes each Axis (X, Y, Z)</td> <td></td> </tr> <tr> <td>Shock Test (Non-operation)</td> <td>Acceleration: 50 G Wave: Half-sine Active Time: 20 ms Direction: X, Y, Z (one time for each Axis)</td> <td></td> </tr> <tr> <td>Drop Test</td> <td>Height: 61 cm, package test</td> <td></td> </tr> <tr> <td>Thermal Shock Test (TST)</td> <td>-20°C/30min, 60°C/30min, 100 cycles</td> <td>1</td> </tr> <tr> <td>On/Off Test</td> <td>On/10sec, Off/10sec, 30,000 cycles</td> <td></td> </tr> <tr> <td>ESD (Electro Static Discharge)</td> <td>Contact Discharge: ±8KV, 150pF(3300) 1sec, 8 points, 25 times/point Air Discharge: ±15KV, 150pF(3300) 1sec, 8 points, 25 times/point</td> <td>2</td> </tr> <tr> <td>Altitude Test</td> <td>Operation: 10,000 ft. Non-Operation: 30,000 ft.</td> <td></td> </tr> </tbody> </table>	Items	Required Condition	Note	Temperature Humidity Bias (THB)	Ta=50°C, 80%RH, 300hours		High Temperature Operation (HTO)	Ta=50°C, 300hours		Low Temperature Operation (LTO)	Ta=0°C, 300hours		High Temperature Storage (HTS)	Ta=50°C, 300hours		Low Temperature Storage (LTS)	Ta=-20°C, 300hours		Vibration Test (Non-operation)	Acceleration: 1.5 Gms Wave: Random Frequency: 10~200 Hz Sweep: 30 Minutes each Axis (X, Y, Z)		Shock Test (Non-operation)	Acceleration: 50 G Wave: Half-sine Active Time: 20 ms Direction: X, Y, Z (one time for each Axis)		Drop Test	Height: 61 cm, package test		Thermal Shock Test (TST)	-20°C/30min, 60°C/30min, 100 cycles	1	On/Off Test	On/10sec, Off/10sec, 30,000 cycles		ESD (Electro Static Discharge)	Contact Discharge: ±8KV, 150pF(3300) 1sec, 8 points, 25 times/point Air Discharge: ±15KV, 150pF(3300) 1sec, 8 points, 25 times/point	2	Altitude Test	Operation: 10,000 ft. Non-Operation: 30,000 ft.																																																																																																																																																		
Items	Required Condition	Note																																																																																																																																																																																																																																	
Temperature Humidity Bias (THB)	Ta=50°C, 80%RH, 300hours																																																																																																																																																																																																																																		
High Temperature Operation (HTO)	Ta=50°C, 300hours																																																																																																																																																																																																																																		
Low Temperature Operation (LTO)	Ta=0°C, 300hours																																																																																																																																																																																																																																		
High Temperature Storage (HTS)	Ta=50°C, 300hours																																																																																																																																																																																																																																		
Low Temperature Storage (LTS)	Ta=-20°C, 300hours																																																																																																																																																																																																																																		
Vibration Test (Non-operation)	Acceleration: 1.5 Gms Wave: Random Frequency: 10~200 Hz Sweep: 30 Minutes each Axis (X, Y, Z)																																																																																																																																																																																																																																		
Shock Test (Non-operation)	Acceleration: 50 G Wave: Half-sine Active Time: 20 ms Direction: X, Y, Z (one time for each Axis)																																																																																																																																																																																																																																		
Drop Test	Height: 61 cm, package test																																																																																																																																																																																																																																		
Thermal Shock Test (TST)	-20°C/30min, 50°C/30min, 100 cycles	1																																																																																																																																																																																																																																	
On/Off Test	On/10sec, Off/10sec, 30,000 cycles																																																																																																																																																																																																																																		
ESD (Electro Static Discharge)	Contact Discharge: ±8KV, 150pF(3300) 1sec, 8 points, 25 times/point Air Discharge: ±15KV, 150pF(3300) 1sec, 8 points, 25 times/point	2																																																																																																																																																																																																																																	
Altitude Test	Operation: 10,000 ft. Non-Operation: 30,000 ft.																																																																																																																																																																																																																																		
Items	Required Condition	Note																																																																																																																																																																																																																																	
Temperature Humidity Bias (THB)	Ta=50°C, 80%RH, 300hours																																																																																																																																																																																																																																		
High Temperature Operation (HTO)	Ta=50°C, 300hours																																																																																																																																																																																																																																		
Low Temperature Operation (LTO)	Ta=0°C, 300hours																																																																																																																																																																																																																																		
High Temperature Storage (HTS)	Ta=50°C, 300hours																																																																																																																																																																																																																																		
Low Temperature Storage (LTS)	Ta=-20°C, 300hours																																																																																																																																																																																																																																		
Vibration Test (Non-operation)	Acceleration: 1.5 Gms Wave: Random Frequency: 10~200 Hz Sweep: 30 Minutes each Axis (X, Y, Z)																																																																																																																																																																																																																																		
Shock Test (Non-operation)	Acceleration: 50 G Wave: Half-sine Active Time: 20 ms Direction: X, Y, Z (one time for each Axis)																																																																																																																																																																																																																																		
Drop Test	Height: 61 cm, package test																																																																																																																																																																																																																																		
Thermal Shock Test (TST)	-20°C/30min, 60°C/30min, 100 cycles	1																																																																																																																																																																																																																																	
On/Off Test	On/10sec, Off/10sec, 30,000 cycles																																																																																																																																																																																																																																		
ESD (Electro Static Discharge)	Contact Discharge: ±8KV, 150pF(3300) 1sec, 8 points, 25 times/point Air Discharge: ±15KV, 150pF(3300) 1sec, 8 points, 25 times/point	2																																																																																																																																																																																																																																	
Altitude Test	Operation: 10,000 ft. Non-Operation: 30,000 ft.																																																																																																																																																																																																																																		
	13	<table border="1"> <thead> <tr> <th>Symbol</th> <th>Parameter</th> <th>Min.</th> <th>Typ.</th> <th>Max.</th> <th>Unit</th> <th>Remark</th> </tr> </thead> <tbody> <tr> <td>VCC</td> <td>Input Voltage</td> <td>10.8</td> <td>12</td> <td>13.2</td> <td>[Volt]</td> <td></td> </tr> <tr> <td>I_{CC}</td> <td>Input Current</td> <td>1.08</td> <td>-</td> <td>-</td> <td>[A]</td> <td>100% PWM Duty</td> </tr> <tr> <td>P_{CC}</td> <td>Power Consumption</td> <td>12.96</td> <td>14.256</td> <td>-</td> <td>[Watt]</td> <td>100% PWM Duty</td> </tr> <tr> <td>I_{INRUSH}</td> <td>Inrush Current</td> <td>-</td> <td>3</td> <td>6.5</td> <td>[A]</td> <td>at rising time=470us</td> </tr> <tr> <td>VLED on/off</td> <td>On Control Voltage</td> <td>3</td> <td>5</td> <td>5.5</td> <td>[Volt]</td> <td></td> </tr> <tr> <td></td> <td>Off Control Voltage</td> <td>-</td> <td>0.8</td> <td>-</td> <td>[Volt]</td> <td></td> </tr> <tr> <td></td> <td>Dimming Frequency</td> <td>200</td> <td>-</td> <td>20k</td> <td>[Hz]</td> <td></td> </tr> <tr> <td></td> <td>Swing Voltage</td> <td>3</td> <td>3.3</td> <td>5</td> <td>[V]</td> <td></td> </tr> <tr> <td>F_{FWW}</td> <td>High Voltage</td> <td>3</td> <td>3.3</td> <td>5</td> <td>[Volt]</td> <td></td> </tr> <tr> <td></td> <td>Low Voltage</td> <td>-</td> <td>0.8</td> <td>-</td> <td>[Volt]</td> <td></td> </tr> <tr> <td></td> <td>Dimming Duty Cycle</td> <td>5</td> <td>-</td> <td>100</td> <td>[%]</td> <td></td> </tr> <tr> <td>I_F</td> <td>LED Forward Current</td> <td>60</td> <td>-</td> <td>-</td> <td>[mA]</td> <td>Ta=25°C</td> </tr> <tr> <td>V_F</td> <td>LED Forward Voltage</td> <td>3.1</td> <td>3.4</td> <td>-</td> <td>[Volt]</td> <td>I_F=60mA, Ta=25°C</td> </tr> <tr> <td>P_{LED}</td> <td>LED Power Consumption</td> <td>0.188</td> <td>0.204</td> <td>-</td> <td>[Watt]</td> <td>I_F=60mA, Ta=25°C</td> </tr> <tr> <td>Operation Lifetime</td> <td></td> <td>50,000</td> <td>-</td> <td>-</td> <td>[Hrs]</td> <td>I_F=60mA, Ta=25°C</td> </tr> </tbody> </table>	Symbol	Parameter	Min.	Typ.	Max.	Unit	Remark	VCC	Input Voltage	10.8	12	13.2	[Volt]		I _{CC}	Input Current	1.08	-	-	[A]	100% PWM Duty	P _{CC}	Power Consumption	12.96	14.256	-	[Watt]	100% PWM Duty	I _{INRUSH}	Inrush Current	-	3	6.5	[A]	at rising time=470us	VLED on/off	On Control Voltage	3	5	5.5	[Volt]			Off Control Voltage	-	0.8	-	[Volt]			Dimming Frequency	200	-	20k	[Hz]			Swing Voltage	3	3.3	5	[V]		F _{FWW}	High Voltage	3	3.3	5	[Volt]			Low Voltage	-	0.8	-	[Volt]			Dimming Duty Cycle	5	-	100	[%]		I _F	LED Forward Current	60	-	-	[mA]	Ta=25°C	V _F	LED Forward Voltage	3.1	3.4	-	[Volt]	I _F =60mA, Ta=25°C	P _{LED}	LED Power Consumption	0.188	0.204	-	[Watt]	I _F =60mA, Ta=25°C	Operation Lifetime		50,000	-	-	[Hrs]	I _F =60mA, Ta=25°C	<table border="1"> <thead> <tr> <th>Symbol</th> <th>Parameter</th> <th>Min.</th> <th>Typ.</th> <th>Max.</th> <th>Unit</th> <th>Remark</th> </tr> </thead> <tbody> <tr> <td>VCC</td> <td>Input Voltage</td> <td>10.8</td> <td>12</td> <td>13.2</td> <td>[Volt]</td> <td></td> </tr> <tr> <td>I_{CC}</td> <td>Input Current</td> <td>1.17</td> <td>1.404</td> <td>-</td> <td>[A]</td> <td>100% PWM Duty</td> </tr> <tr> <td>P_{CC}</td> <td>Power Consumption</td> <td>14.04</td> <td>16.848</td> <td>-</td> <td>[Watt]</td> <td>100% PWM Duty</td> </tr> <tr> <td>I_{INRUSH}</td> <td>Inrush Current</td> <td>-</td> <td>3</td> <td>6.5</td> <td>[A]</td> <td>at rising time=470us</td> </tr> <tr> <td>VLED on/off</td> <td>On Control Voltage</td> <td>3</td> <td>5</td> <td>5.5</td> <td>[Volt]</td> <td></td> </tr> <tr> <td></td> <td>Off Control Voltage</td> <td>-</td> <td>0.8</td> <td>-</td> <td>[Volt]</td> <td></td> </tr> <tr> <td></td> <td>Dimming Frequency</td> <td>200</td> <td>-</td> <td>20k</td> <td>[Hz]</td> <td></td> </tr> <tr> <td></td> <td>Swing Voltage</td> <td>3</td> <td>3.3</td> <td>5</td> <td>[V]</td> <td></td> </tr> <tr> <td>F_{FWW}</td> <td>High Voltage</td> <td>3</td> <td>3.3</td> <td>5</td> <td>[Volt]</td> <td></td> </tr> <tr> <td></td> <td>Low Voltage</td> <td>-</td> <td>0.8</td> <td>-</td> <td>[Volt]</td> <td></td> </tr> <tr> <td></td> <td>Dimming Duty Cycle</td> <td>5</td> <td>-</td> <td>100</td> <td>[%]</td> <td></td> </tr> <tr> <td>I_F</td> <td>LED Forward Current</td> <td>65</td> <td>-</td> <td>-</td> <td>[mA]</td> <td>Ta=25°C</td> </tr> <tr> <td>V_F</td> <td>LED Forward Voltage</td> <td>3.1</td> <td>3.4</td> <td>-</td> <td>[Volt]</td> <td>I_F=65mA, Ta=25°C</td> </tr> <tr> <td>P_{LED}</td> <td>LED Power Consumption</td> <td>0.201</td> <td>0.221</td> <td>-</td> <td>[Watt]</td> <td>I_F=65mA, Ta=25°C</td> </tr> <tr> <td>Operation Lifetime</td> <td></td> <td>50,000</td> <td>-</td> <td>-</td> <td>[Hrs]</td> <td>I_F=65mA, Ta=25°C</td> </tr> </tbody> </table>	Symbol	Parameter	Min.	Typ.	Max.	Unit	Remark	VCC	Input Voltage	10.8	12	13.2	[Volt]		I _{CC}	Input Current	1.17	1.404	-	[A]	100% PWM Duty	P _{CC}	Power Consumption	14.04	16.848	-	[Watt]	100% PWM Duty	I _{INRUSH}	Inrush Current	-	3	6.5	[A]	at rising time=470us	VLED on/off	On Control Voltage	3	5	5.5	[Volt]			Off Control Voltage	-	0.8	-	[Volt]			Dimming Frequency	200	-	20k	[Hz]			Swing Voltage	3	3.3	5	[V]		F _{FWW}	High Voltage	3	3.3	5	[Volt]			Low Voltage	-	0.8	-	[Volt]			Dimming Duty Cycle	5	-	100	[%]		I _F	LED Forward Current	65	-	-	[mA]	Ta=25°C	V _F	LED Forward Voltage	3.1	3.4	-	[Volt]	I _F =65mA, Ta=25°C	P _{LED}	LED Power Consumption	0.201	0.221	-	[Watt]	I _F =65mA, Ta=25°C	Operation Lifetime		50,000	-	-	[Hrs]	I _F =65mA, Ta=25°C
Symbol	Parameter	Min.	Typ.	Max.	Unit	Remark																																																																																																																																																																																																																													
VCC	Input Voltage	10.8	12	13.2	[Volt]																																																																																																																																																																																																																														
I _{CC}	Input Current	1.08	-	-	[A]	100% PWM Duty																																																																																																																																																																																																																													
P _{CC}	Power Consumption	12.96	14.256	-	[Watt]	100% PWM Duty																																																																																																																																																																																																																													
I _{INRUSH}	Inrush Current	-	3	6.5	[A]	at rising time=470us																																																																																																																																																																																																																													
VLED on/off	On Control Voltage	3	5	5.5	[Volt]																																																																																																																																																																																																																														
	Off Control Voltage	-	0.8	-	[Volt]																																																																																																																																																																																																																														
	Dimming Frequency	200	-	20k	[Hz]																																																																																																																																																																																																																														
	Swing Voltage	3	3.3	5	[V]																																																																																																																																																																																																																														
F _{FWW}	High Voltage	3	3.3	5	[Volt]																																																																																																																																																																																																																														
	Low Voltage	-	0.8	-	[Volt]																																																																																																																																																																																																																														
	Dimming Duty Cycle	5	-	100	[%]																																																																																																																																																																																																																														
I _F	LED Forward Current	60	-	-	[mA]	Ta=25°C																																																																																																																																																																																																																													
V _F	LED Forward Voltage	3.1	3.4	-	[Volt]	I _F =60mA, Ta=25°C																																																																																																																																																																																																																													
P _{LED}	LED Power Consumption	0.188	0.204	-	[Watt]	I _F =60mA, Ta=25°C																																																																																																																																																																																																																													
Operation Lifetime		50,000	-	-	[Hrs]	I _F =60mA, Ta=25°C																																																																																																																																																																																																																													
Symbol	Parameter	Min.	Typ.	Max.	Unit	Remark																																																																																																																																																																																																																													
VCC	Input Voltage	10.8	12	13.2	[Volt]																																																																																																																																																																																																																														
I _{CC}	Input Current	1.17	1.404	-	[A]	100% PWM Duty																																																																																																																																																																																																																													
P _{CC}	Power Consumption	14.04	16.848	-	[Watt]	100% PWM Duty																																																																																																																																																																																																																													
I _{INRUSH}	Inrush Current	-	3	6.5	[A]	at rising time=470us																																																																																																																																																																																																																													
VLED on/off	On Control Voltage	3	5	5.5	[Volt]																																																																																																																																																																																																																														
	Off Control Voltage	-	0.8	-	[Volt]																																																																																																																																																																																																																														
	Dimming Frequency	200	-	20k	[Hz]																																																																																																																																																																																																																														
	Swing Voltage	3	3.3	5	[V]																																																																																																																																																																																																																														
F _{FWW}	High Voltage	3	3.3	5	[Volt]																																																																																																																																																																																																																														
	Low Voltage	-	0.8	-	[Volt]																																																																																																																																																																																																																														
	Dimming Duty Cycle	5	-	100	[%]																																																																																																																																																																																																																														
I _F	LED Forward Current	65	-	-	[mA]	Ta=25°C																																																																																																																																																																																																																													
V _F	LED Forward Voltage	3.1	3.4	-	[Volt]	I _F =65mA, Ta=25°C																																																																																																																																																																																																																													
P _{LED}	LED Power Consumption	0.201	0.221	-	[Watt]	I _F =65mA, Ta=25°C																																																																																																																																																																																																																													
Operation Lifetime		50,000	-	-	[Hrs]	I _F =65mA, Ta=25°C																																																																																																																																																																																																																													
	10	<p>4.2 Absolute Ratings of Environment</p> <table border="1"> <thead> <tr> <th>Item</th> <th>Symbol</th> <th>Min.</th> <th>Max.</th> <th>Unit</th> <th>Conditions</th> </tr> </thead> <tbody> <tr> <td>Operating Temperature</td> <td>TOP</td> <td>0</td> <td>50</td> <td>[°C]</td> <td rowspan="5">Note 3 & 4</td> </tr> <tr> <td>Operation Humidity</td> <td>HOP</td> <td>5</td> <td>90</td> <td>[%RH]</td> </tr> <tr> <td>Storage Temperature</td> <td>TST</td> <td>-20</td> <td>60</td> <td>[°C]</td> </tr> <tr> <td>Storage Humidity</td> <td>HST</td> <td>5</td> <td>90</td> <td>[%RH]</td> </tr> </tbody> </table> <p>Note 1: With in Ta (25°C). Note 2: Permanent damage to the device may occur if exceeding maximum values. Note 3: For quality performance, please refer to AUO IIS (Incoming Inspection Standard). Note 4: Operation Temperature +50°C is defined as panel surface temperature.</p>	Item	Symbol	Min.	Max.	Unit	Conditions	Operating Temperature	TOP	0	50	[°C]	Note 3 & 4	Operation Humidity	HOP	5	90	[%RH]	Storage Temperature	TST	-20	60	[°C]	Storage Humidity	HST	5	90	[%RH]	<p>4.2 Absolute Ratings of Environment</p> <table border="1"> <thead> <tr> <th>Item</th> <th>Symbol</th> <th>Min.</th> <th>Max.</th> <th>Unit</th> <th>Conditions</th> </tr> </thead> <tbody> <tr> <td>Operating Temperature</td> <td>TOP</td> <td>0</td> <td>50</td> <td>[°C]</td> <td rowspan="5">Note 3 & 4</td> </tr> <tr> <td>Operation Humidity</td> <td>HOP</td> <td>5</td> <td>90</td> <td>[%RH]</td> </tr> <tr> <td>Storage Temperature</td> <td>TST</td> <td>-20</td> <td>60</td> <td>[°C]</td> </tr> <tr> <td>Storage Humidity</td> <td>HST</td> <td>5</td> <td>90</td> <td>[%RH]</td> </tr> </tbody> </table> <p>Note 1: With in Ta (25°C). Note 2: Permanent damage to the device may occur if exceeding maximum values. Note 3: For quality performance, please refer to AUO IIS (Incoming Inspection Standard). Note 4: Operation Temperature +50°C is defined as panel surface temperature. Note 5: panel surface temperature. TGS Max 60°C (Function judge only).</p>	Item	Symbol	Min.	Max.	Unit	Conditions	Operating Temperature	TOP	0	50	[°C]	Note 3 & 4	Operation Humidity	HOP	5	90	[%RH]	Storage Temperature	TST	-20	60	[°C]	Storage Humidity	HST	5	90	[%RH]																																																																																																																																																																										
Item	Symbol	Min.	Max.	Unit	Conditions																																																																																																																																																																																																																														
Operating Temperature	TOP	0	50	[°C]	Note 3 & 4																																																																																																																																																																																																																														
Operation Humidity	HOP	5	90	[%RH]																																																																																																																																																																																																																															
Storage Temperature	TST	-20	60	[°C]																																																																																																																																																																																																																															
Storage Humidity	HST	5	90	[%RH]																																																																																																																																																																																																																															
Item	Symbol	Min.	Max.	Unit		Conditions																																																																																																																																																																																																																													
Operating Temperature	TOP	0	50	[°C]	Note 3 & 4																																																																																																																																																																																																																														
Operation Humidity	HOP	5	90	[%RH]																																																																																																																																																																																																																															
Storage Temperature	TST	-20	60	[°C]																																																																																																																																																																																																																															
Storage Humidity	HST	5	90	[%RH]																																																																																																																																																																																																																															
	1	Preliminary Specification	Final Specification																																																																																																																																																																																																																																
1.1 / 2019/2/18	5	Operating 0~50 °C	Operating 0~60 °C																																																																																																																																																																																																																																

1.0 Handling Precautions

- 1) Since front polarizer is easily damaged, pay attention not to scratch it.
- 2) Be sure to turn off power supply when inserting or disconnecting from input connector.
- 3) Wipe off water drop immediately. Long contact with water may cause discoloration or spots.
- 4) When the panel surface is soiled, wipe it with absorbent cotton or other soft cloth.
- 5) Since the panel is made of glass, it may break or crack if dropped or bumped on hard surface.
- 6) Since CMOS LSI is used in this module, take care of static electricity and insure human earth when handling.
- 7) Do not open or modify the Module Assembly.
- 8) Do not press the reflector sheet at the back of the module to any directions.
- 9) In case if a Module has to be put back into the packing container slot after it was taken out from the container, do not press the center of LED lightbar edge. Instead, press at the far ends of the LED light bar edge softly. Otherwise the TFT Module may be damaged.
- 10) At the insertion or removal of the Signal Interface Connector, be sure not to rotate nor tilt the Interface Connector of the TFT Module.
- 11) After installation of the TFT Module into an enclosure, do not twist nor bend the TFT Module even momentarily. While designing the enclosure, it should be taken into consideration that no bending/twisting forces are applied to the TFT Module from outside. Otherwise the TFT Module may be damaged.
- 12) Small amount of materials having no flammability grade is used in the LCD module. The LCD module should be supplied by power complied with requirements of Limited Power Source (IEC60950-1 or UL60950-1), or be applied exemption.

2.0 General Description

This specification applies to the 21.5 inch-wide Color AHVA (IPS-like) TFT-LCD Module G215HAN01.0. The display supports the FHD [1920(H) x 1080(V)] screen format and 16.7M colors (True 8 bit). All input signals are LVDS interface compatible.

2.1 Display Characteristics

The following items are characteristics summary on the table under 25°C condition:

ITEMS	Unit	SPECIFICATIONS
Screen Diagonal	[mm]	546.86 (21.5")
Active Area	[mm]	476.064 (H) x 267.786 (V)
Pixels H x V		1920(x3) x 1080
Pixel Pitch	[um]	247.95 (per one triad) x247.95
Pixel Arrangement		R.G.B. Vertical Stripe
Display Mode		AHVA Mode, Normally Black
White Luminance (Center)	[cd/m ²]	400 cd/m ² (Typ.)
Contrast Ratio		1000 (Typ.)
Optical Response Time	[msec]	22
Nominal Input Voltage VDD	[Volt]	5 V (Typ)
Power Consumption (VDD line + LED line)	[Watt]	18.44W
Weight	[Grams]	2100 (Typ)
Physical Size	[mm]	497.6(H) x 292.2(V) x 17.7 (D)Typ
Electrical Interface		Dual LVDS
Support Color		16.7M colors, True 8 bit
Surface Treatment		Anti-Glare, 3H
RoHS Compliance		RoHS Compliance
Temperature Range		
Operating	[°C]	0~ 60
Storage (Shipping)	[°C]	-20~ 60

2.2 Optical Characteristics

The optical characteristics are measured under stable conditions at 25 °C:

Item	Unit	Conditions	Min.	Typ.	Max.	Note
Viewing Angle	[degree]	Horizontal (Right) CR >10		89	-	2
		(Left)		89	-	
		Vertical (Up) CR > 10		89	-	
		(Down)		89	-	
Contrast ratio		Normal Direction	800	1000	-	3
Response Time	[msec]	Raising Time (T _{rR})		12	22	4
		Falling Time (T _{rF})		10	20	
		Raising + Falling		22	42	
Color / Chromaticity Coordinates (CIE)		Red x	0.609	0.639	0.669	5
		Red y	0.304	0.334	0.364	
		Green x	0.282	0.312	0.342	
		Green y	0.599	0.629	0.659	
		Blue x	0.130	0.160	0.190	
		Blue y	0.029	0.059	0.089	
Color Coordinates (CIE) White		White x	0.283	0.313	0.343	
		White y	0.299	0.329	0.359	
Central Luminance	[cd/m ²]		320	400		6
Luminance Uniformity	[%]		80	85		7
Color Gamut	%			72		

Note 1: Measurement method

The LCD module should be stabilized at given temperature for 30 minutes to avoid abrupt temperature change during measuring (at surface 35°C). In order to stabilize the luminance, the measurement should be executed after lighting Backlight for 30 minutes in a stable, windless and dark room.

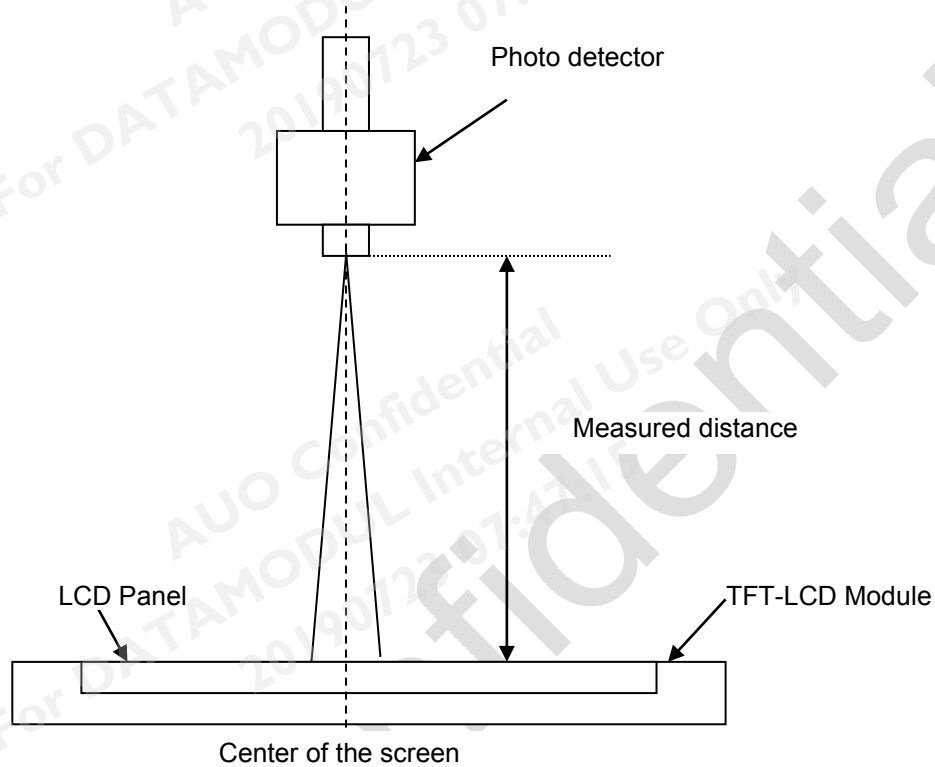

Note 2: Definition of viewing angle measured by ELDIM (EZContrast 88)

Viewing angle is the measurement of contrast ratio ≥ 10 , at the screen center, over a 180° horizontal and 180° vertical range (off-normal viewing angles). The 180° viewing angle range is broken down as follows; 90° (θ) horizontal left and right and 90° (Φ) vertical, high (up) and low (down). The measurement direction is typically perpendicular to the display surface with the screen rotated about its center to develop the desired measurement viewing angle.

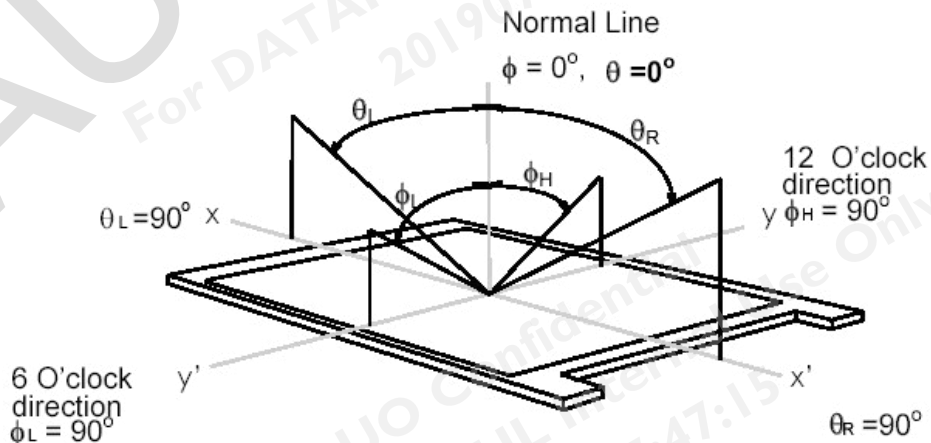

Note 3: Contrast ratio is measured by TOPCON SR-3

Note 4: Definition of Response time measured by Westar TRD-100A

The output signals of photo detector are measured when the input signals are changed from “Full Black” to “Full White” (rising time, T_{rR}), and from “Full White” to “Full Black” (falling time, T_{rF}), respectively. The response time is interval between the 10% and 90% (1 frame at 60 Hz) of amplitudes. $T_{rR} + T_{rF} = 5 \text{ msec (typ.)}$.

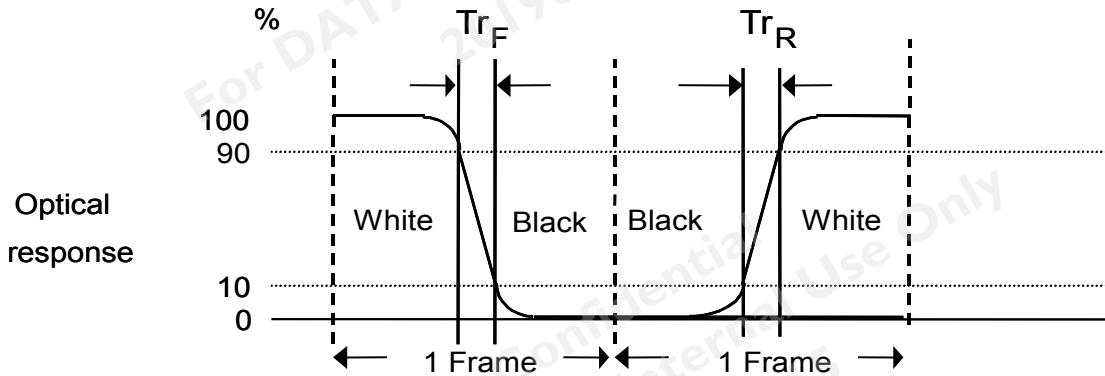

Note 5: Color chromaticity and coordinates (CIE) is measured by TOPCON SR-3

Note 6: Central luminance is measured by TOPCON SR-3

Note 7: Luminance uniformity of these 9 points is defined as below and measured by TOPCON SR-3

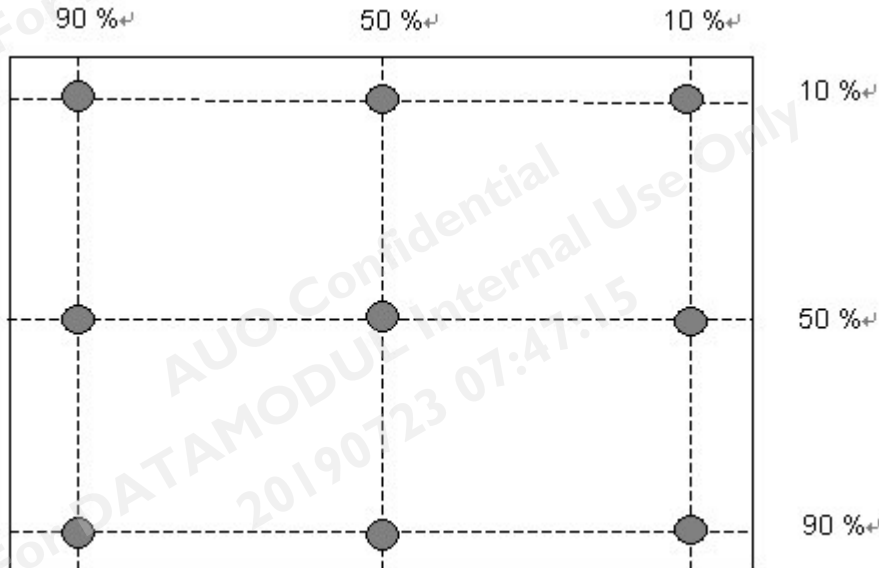

$$\text{Uniformity} = \frac{\text{Minimum Luminance in 9 points (1-9)}}{\text{Maximum Luminance in 9 Points (1-9)}}$$

3.0 Functional Block Diagram

The following diagram shows the functional block of the 21.5 inch Color TFT-LCD Module:

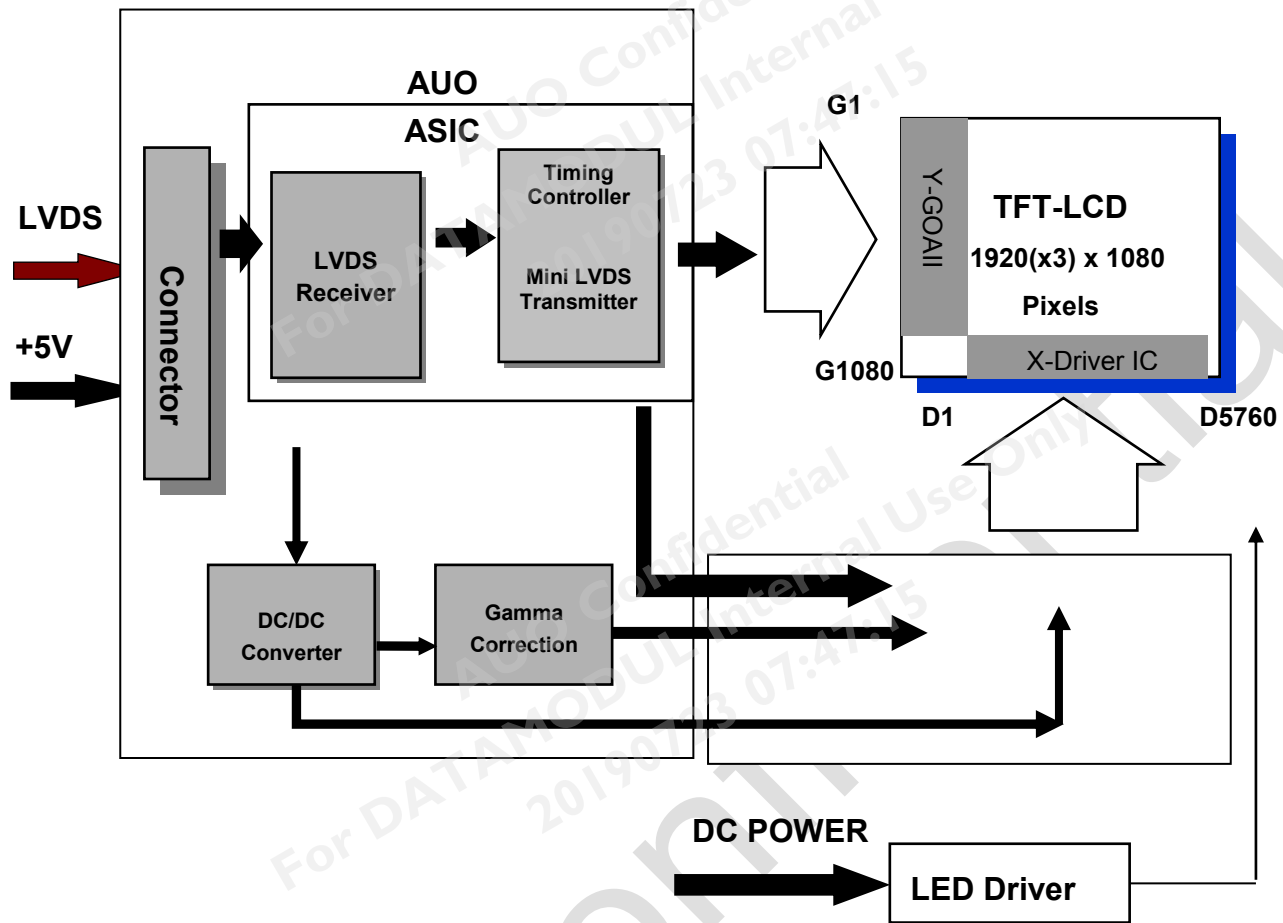

I/F PCB Interface:

Connector: FI-XB30SSRLA-HF16-R3500(JAE 30pin)

Mating Type:

FI-X30HL or FI-X30C2L-NPB

4.0 Absolute Maximum Ratings

Absolute maximum ratings of the module are as following:

4.1 TFT LCD Module

Item	Symbol	Min	Max	Unit	Conditions
Logic/LCD Drive Voltage	VDD	-0.3	+5.5	[Volt]	Note 1,2

4.2 Absolute Ratings of Environment

Item	Symbol	Min.	Max.	Unit	Conditions
Operating Temperature	TOP	0	60	[°C]	Note 3 & 4
Operation Humidity	HOP	5	90	[%RH]	
Storage Temperature	TST	-20	60	[°C]	
Storage Humidity	HST	5	90	[%RH]	

Note 1: With in Ta (25 °C)

Note 2: Permanent damage to the device may occur if exceeding maximum values

Note 3: For quality performance, please refer to AUO IIS(Incoming Inspection Standard).

Note 4: Operation Temperature +60°C is defined as panel surface temperature.

Note 5: panel surface temperature. TGS Max 60C (Function judge only)



5.0 Electrical characteristics

5.1 TFT LCD Module

5.1.1 Power Specification

Input power specifications are as follows:

Symbol	Parameter	Min	Typ	Max	Unit	Conditions
VDD	Logic/LCD Drive Voltage	4.5	5.0	5.5	[Volt]	+/-10%
IDD	Input Current	-	0.88	1.056	[A]	VDD= 5.0V, All White Pattern At 60Hz,
PDD	VDD Power	-	4.4	4.84	[Watt]	VDD= 5.0V, All White Pattern At 60Hz
IRush	Inrush Current	-	2.7	3.4	[A]	Note 1
VDDrp	Allowable Logic/LCD Drive Ripple Voltage	-	-	300	[mV] p-p	VDD= 5.0V, All White Pattern At 60Hz

Note 1: Measurement conditions:

The duration of rising time of power input is 470us.

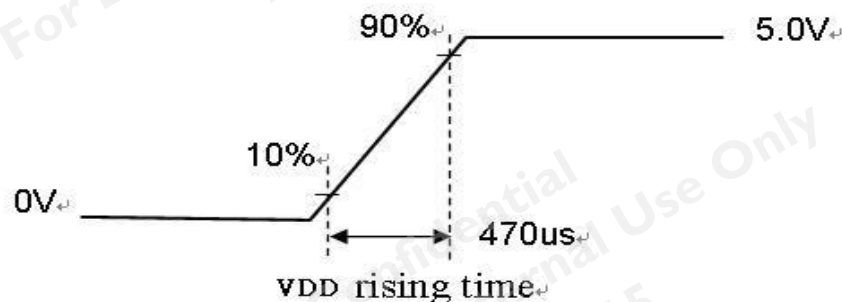
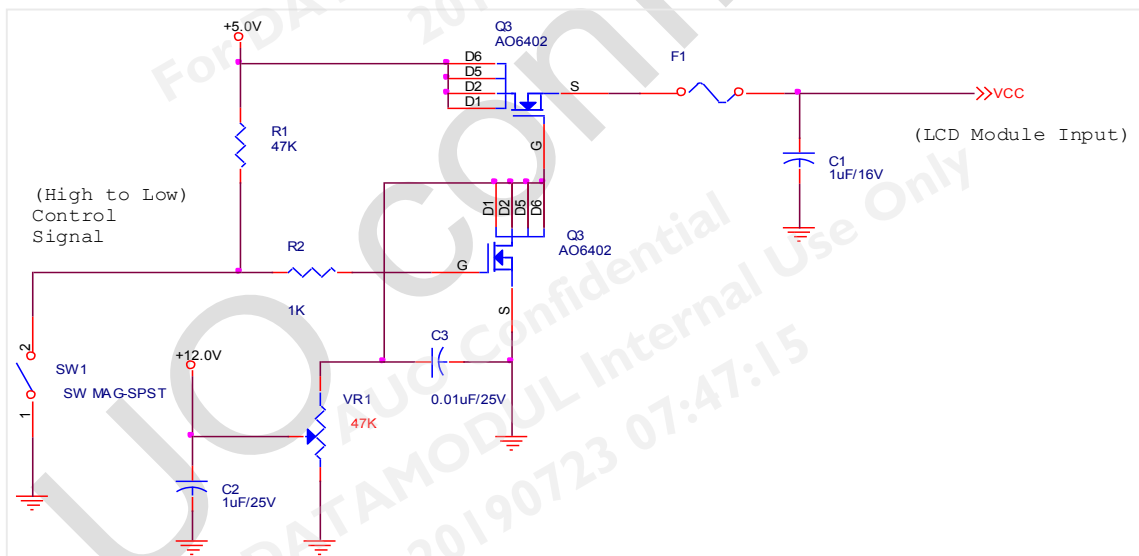

5.1.2 Signal Electrical Characteristics

Input signals shall be low or Hi-Z state when VDD is off. Please refer to specifications of SN75LVDS82DGG (Texas Instruments) in detail.

Characteristics of each signal are as follows:

Symbol	Parameter	Min	Typ	Max	Units	Condition
VTH	Differential Input High Threshold	-		100	[mV]	VICM = 1.2V Note 1
VTL	Differential Input Low Threshold	-100		-	[mV]	VICM = 1.2V Note 1
VID	Input Differential Voltage	100	400	600	[mV]	Note 1
VICM	Differential Input Common Mode Voltage	1.125	-	1.375	[V]	VTH-VTL = 200mV (max) Note 1

Note 1: LVDS Signal Waveform

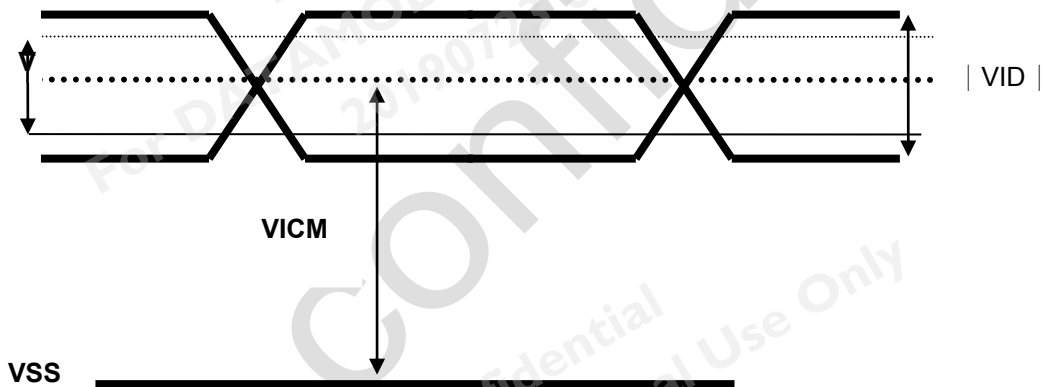

5.2 Backlight Unit (OM)

Following characteristics are measured under a stable condition at 25 °C (Room Temperature):

Symbol	Parameter	Min.	Typ.	Max.	Unit	Remark
VCC	Input Voltage	10.8	12	13.2	[Volt]	
I_{VCC}	Input Current		1.17	1.404	[A]	100% PWM Duty
P_{VCC}	Power Consumption		14.04	16.848	[Watt]	100% PWM Duty
I_{rush LED}	Inrush Current	-		3	[A]	at rising time=470us
V_{LED on/off}	On Control Voltage	3	5	5.5	Volt	
	Off Control Voltage			0.8	Volt	
F_{PWM}	Dimming Frequency	200	-	20k	[Hz]	
	Swing Voltage	3	3.3	5	V	
	High Voltage	3	3.3	5	Volt	
	Low Voltage			0.8	Volt	
	Dimming Duty Cycle	5	-	100	%	
I_F	LED Forward Current		65		mA	Ta = 25 °C
V_F	LED Forward Voltage	-	3.1	3.4	Volt	I _F =65mA, Ta = 25°C
P_{LED}	LED Power Consumption	-	0.201	0.221	Watt	I _F =65mA, Ta = 25°C
Operation Lifetime		50,000			Hrs	I _F =65mA, Ta= 25°C

Note 1: Ta means ambient temperature of TFT-LCD module.

Note 2: VCC, I_{VCC}, P_{VCC}, I_{rush LED} are defined for LED B/L.(100% duty of PWM dimming)

Note 3: I_F, V_F, P_{LED} are defined for single LED.

Note 4: If G215HAN01.0 module is driven by high current or at high ambient temperature & humidity condition. The operating life will be reduced.

Note 5: Operation life means brightness goes down to 50% initial brightness. Minimum operating life time is estimated data.

Note 6: Each LED light bar consists of 63 pcs LED package (7 strings x 9 pcs / string)

6.2 The input data format

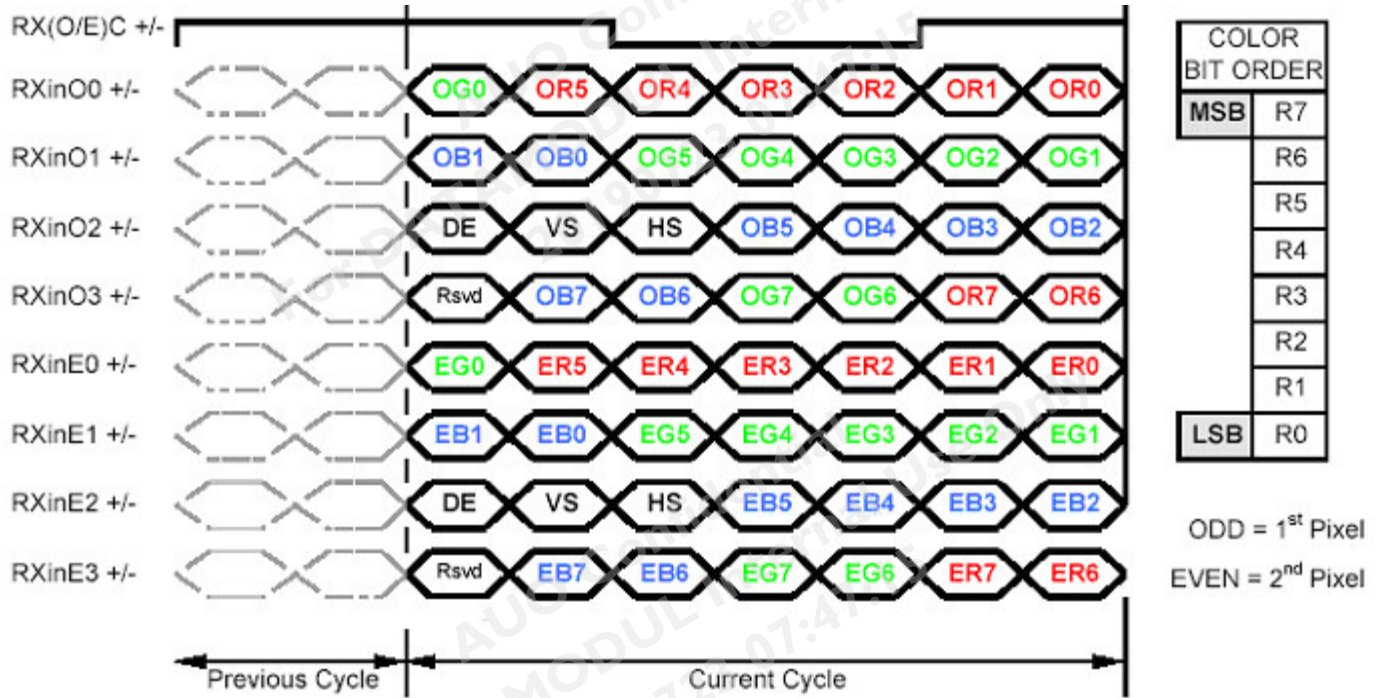

Note1: Normally DE mode only. VS and HS on EVEN channel are not used.

Note2: Please follow VESA.

Note3: 8-bits signal input.

6.3 Signal Description

The module using a pair of LVDS receiver **SN75LVDS82 / SN75LVDS83** (Texas Instruments) or compatible. LVDS is a differential signal technology for LCD interface and high speed data transfer device. Transmitter shall be SN75LVDS83(negative edge sampling) or compatible. The first LVDS port(RxOxxx) transmits odd pixels while the second LVDS port(RxExxx) transmits even pixels.

PIN #	SIGNAL NAME	DESCRIPTION
1	RXOIN0-	Negative LVDS differential data input (Odd data)
2	RXOIN0+	Positive LVDS differential data input (Odd data)
3	RXOIN1-	Negative LVDS differential data input (Odd data)
4	RXOIN1+	Positive LVDS differential data input (Odd data)
5	RXOIN2-	Negative LVDS differential data input (Odd data, H-Sync,V-Sync,DSPTMG)
6	RXOIN2+	Positive LVDS differential data input (Odd data, H-Sync,V-Sync,DSPTMG)
7	GND	Power Ground
8	RXOCLKIN-	Negative LVDS differential clock input (Odd clock)
9	RXOCLKIN+	Positive LVDS differential clock input (Odd clock)
10	RXOIN3-	Negative LVDS differential data input (Odd data)
11	RXOIN3+	Positive LVDS differential data input (Odd data)
12	RXEIN0-	Negative LVDS differential data input (Even data)
13	RXEIN0+	Positive LVDS differential data input (Even data)
14	GND	Power Ground
15	RXEIN1-	Negative LVDS differential data input (Even data)
16	RXEIN1+	Positive LVDS differential data input (Even data)
17	GND	Power Ground
18	RXEIN2-	Negative LVDS differential data input (Even data)
19	RXEIN2+	Positive LVDS differential data input (Even data)
20	RXECLKIN-	Negative LVDS differential clock input (Even clock)
21	RXECLKIN+	Positive LVDS differential clock input (Even clock)
22	RXEIN3-	Negative LVDS differential data input (Even data)
23	RXEIN3+	Positive LVDS differential data input (Even data)
24	GND	Power GND
25	Aging	NC (GND)
26	SCL for PVCOM	NC (GND)
27	SDA for PVCOM	NC (GND)
28	VDD	+5.0V Power Supply
29	VDD	+5.0V Power Supply
30	VDD	+5.0V Power Supply

Note1: Start from right side

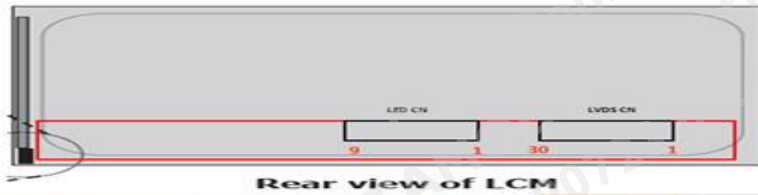

Rear view of LCM



Note2: Input signals of clock shall be the same timing.

Note3: Please follow TV VESA Pin Assignment

6.4 Timing Characteristics

Signal	Item	Symbol	Min	Typ	Max	Unit
V-section	Period	T_v	1090	1100	1160	Th
	Active	$T_{disp}(v)$	1080	1080	1080	Th
	Blanking	$T_{bp}(v)+T_{fp}(v)+PW_{vs}$	10	20	80	Th
H-section	Period	T_h	1000	1088	1120	Tclk
	Active	$T_{disp}(h)$	960	960	960	Tclk
	Blanking	$T_{bp}(h)+T_{fp}(h)+PW_{hs}$	40	128	160	Tclk
Clock	Period	Tclk	11.76	13.89	15.38	ns
	Frequency	Freq.	60	72	87.5	MHz
Frame Rate	Frame Rate	$1/T_v$	50	60	75	Hz

Note 1: Only DE mode operation.

The input of Hsync & Vsync signal does not have an effect upon the LCD normal operation.

Note 2: The performance of the electro-optical characteristics may be influenced by variance of the vertical refresh rates.

Note 3: Horizontal period should be even.

6.5 Timing diagram

Input Timing Definition (DE Mode)

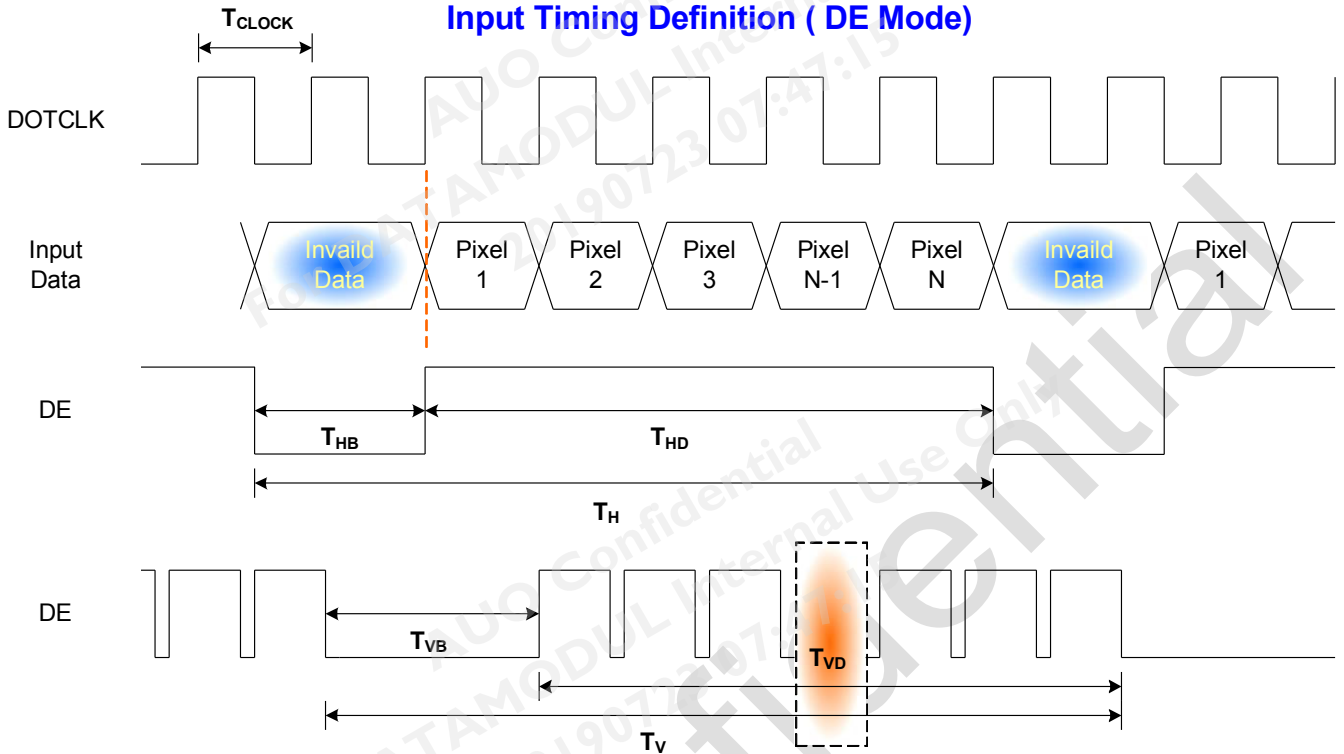

6.6 Power ON/OFF Sequence

VDD power and LED on/off sequence are as follows. Interface signals are also shown in the chart. Signals from any system shall be Hi-Z state or low level when VDD is off.

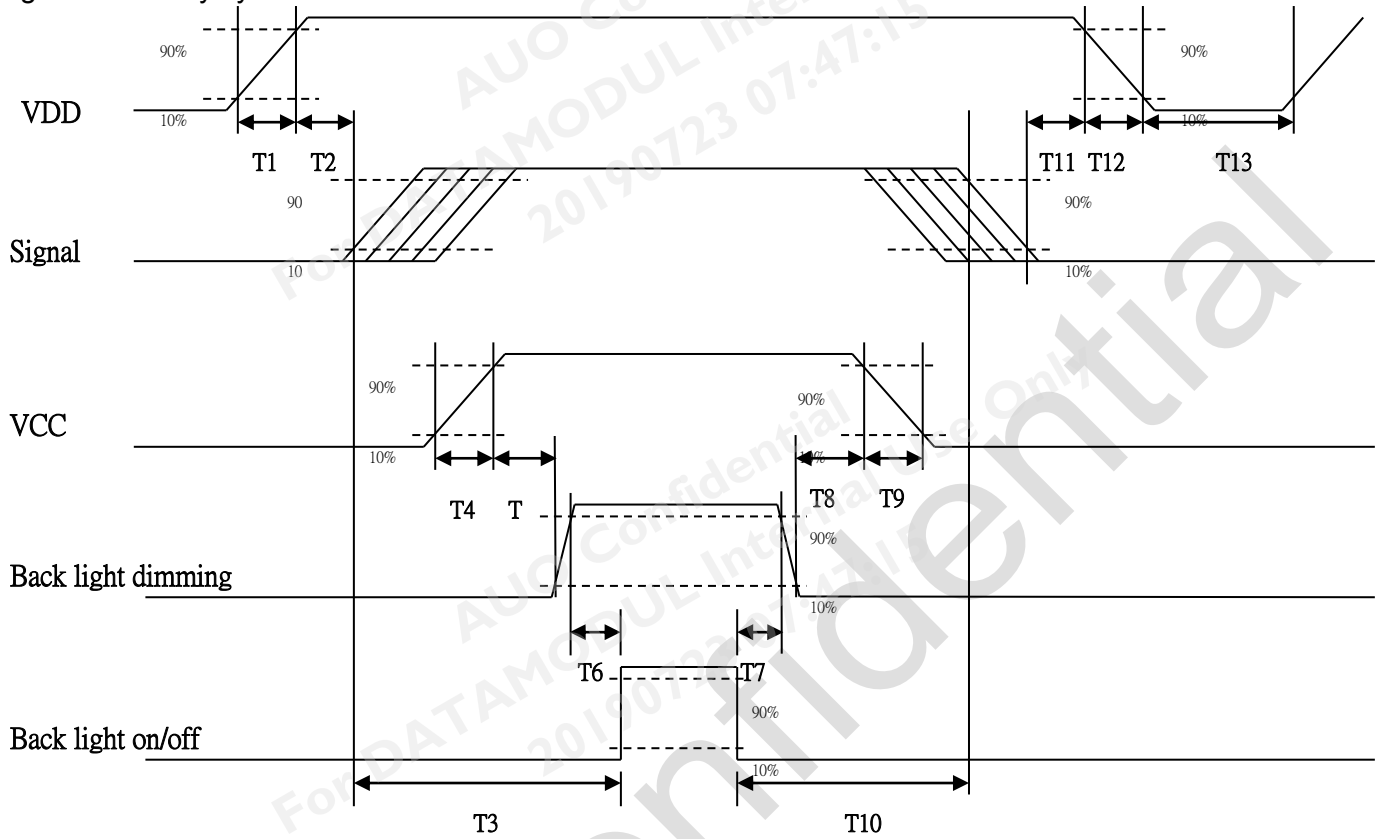

Power ON/OFF sequence timing

Parameter	Value			Units
	Min.	Typ.	Max.	
T1	0.5	-	10	[ms]
T2	0	40	50	[ms]
T3	200	-	-	[ms]
T4	0.5	-	10	[ms]
T5	10	-	-	[ms]
T6	10	-	-	[ms]
T7	0	-	-	[ms]
T8	10	-	-	[ms]
T9	-	-	10	[ms]
T10	110	-	-	[ms]
T11	0.5	16	50	[ms]
T12	-	-	100	[ms]
T13	1000	-	-	[ms]

7.0 Connector & Pin Assignment

Physical interface is described as for the connector on module. These connectors are capable of accommodating the following signals and will be following components.

7.1 TFT LCD Module

Connector Name / Designation	Interface Connector / Interface card
Manufacturer	JAE
Type Part Number	FI-XB30SSRLA-HF16-R3500(JAE 30pin)
Mating Housing Part Number	FI-X30HL or FI-X30C2L-NPB

7.1.1 Pin Assignment

Pin#	Signal Name	Pin#	Signal Name
1	RxOIN0-	2	RxOIN0+
3	RxOIN1-	4	RxOIN1+
5	RxOIN2-	6	RxOIN2+
7	GND	8	RxOCLKIN-
9	RxOCLKIN+	10	RxOIN3-
11	RxOIN3+	12	RxEIN0-
13	RxEIN0+	14	GND
15	RxEIN1-	16	RxEIN1+
17	GND	18	RxEIN2-
19	RxEIN2+	20	RxECLKIN-
21	RxECLKIN+	22	RxEIN3-
23	RxEIN3+	24	GND
25	Aging	26	SCL For PVCOM
27	SDA For PVCOM	28	VDD
29	VDD	30	VDD

7.2 LED Backlight Unit: LED Driver Connector

Connector Name / Designation	LED Connector
Manufacturer	SIN SHENG TERMINAL & MACHINE INC(STM)
Connector Model Number	MS24049HJ
Mating Connector Model Number	P24049

7.3 LED Driver Connector Pin Assignment

Pin#	Signal Name
1	GND
2	GND
3	GND
4	PWM
5	ENABLE
6	NC
7	12V
8	12V
9	12V

8.0 Reliability Test

Environment test conditions are listed as following table.

Items	Required Condition	Note
Temperature Humidity Bias (THB)	Ta= 50°C, 80%RH, 300hours	
High Temperature Operation (HTO)	Ta= 60°C, 300hours	
Low Temperature Operation (LTO)	Ta= 0°C, 300hours	
High Temperature Storage (HTS)	Ta= 60°C, 300hours	
Low Temperature Storage (LTS)	Ta= -20°C, 300hours	
Vibration Test (Non-operation)	Acceleration: 1.5 Grms Wave: Random Frequency: 10 - 200 Hz Sweep: 30 Minutes each Axis (X, Y, Z)	
Shock Test (Non-operation)	Acceleration: 50 G Wave: Half-sine Active Time: 20 ms Direction: ±X, ±Y, ±Z (one time for each Axis)	
Drop Test	Height: 61 cm, package test	
Thermal Shock Test (TST)	-20°C /30min, 60°C /30min, 100 cycles	1
On/Off Test	On/10sec, Off/10sec, 30,000 cycles	
ESD (Electro Static Discharge)	Contact Discharge: ± 8KV, 150pF(330Ω) 1sec, 8 points, 25 times/ point.	2
	Air Discharge: ± 15KV, 150pF(330Ω) 1sec 8 points, 25 times/ point.	
Altitude Test	Operation:10,000 ft Non-Operation:30,000 ft	

Note 1: The TFT-LCD module will not sustain damage after being subjected to 100 cycles of rapid temperature change. A cycle of rapid temperature change consists of varying the temperature from -20°C to 60°C, and back again. Power is not applied during the test. After temperature cycling, the unit is placed in normal room ambient for at least 4 hours before power on.

Note 2: According to EN61000-4-2 , ESD class B: Some performance degradation allowed. No data lost. Self-recoverable. No hardware failures.

Note 3 : Mura shall be ignored after high temperature reliability test.

9.0 Shipping Label & Packaging

9.1 Shipping Label

The label is on the panel as shown below:

(1) Shipping 標籤 (P/N : 82.15B06.003): 90mm *23mm ↵

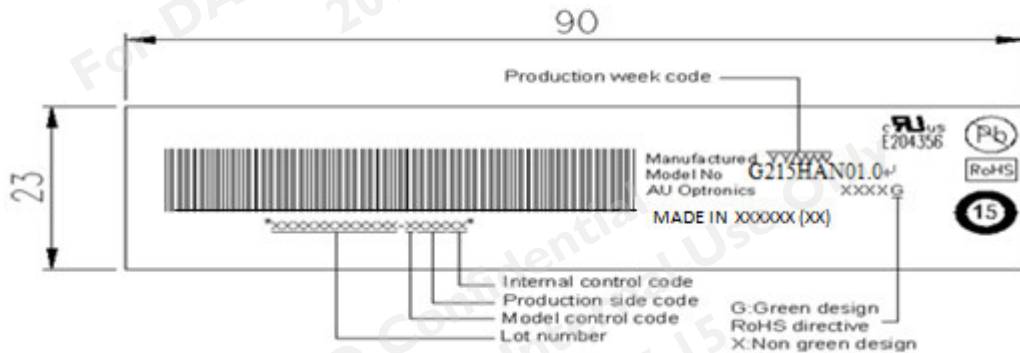

Note 1: For Pb Free products, AUO will add  for identification.

Note 2: For RoHS compatible products, AUO will add  for identification.

Note 3: For China RoHS compatible products, AUO will add  for identification.

Note 4: The Green Mark will be presented only when the green documents have been ready by AUO Internal Green Team.

9.2 Packaging

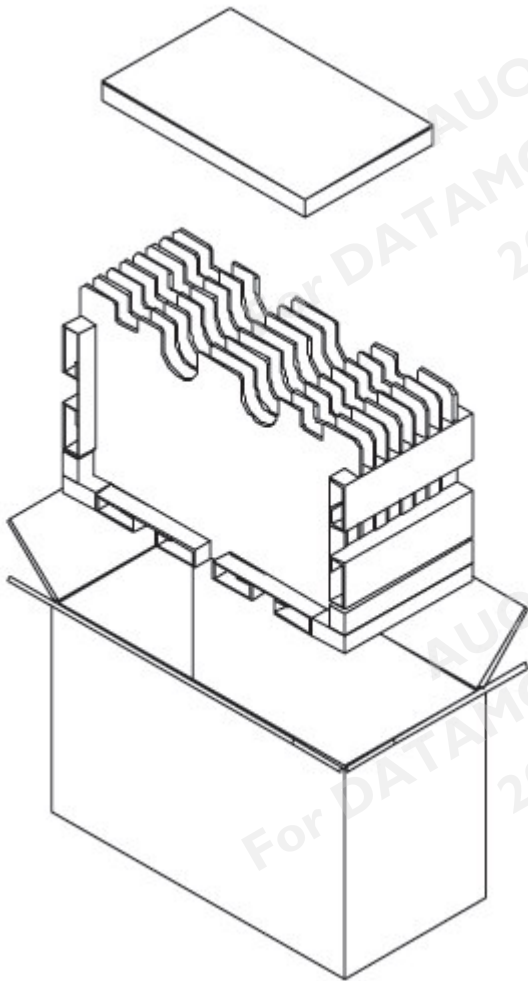

Max capacity : 7 TFT-LCD module per carton

Max weight: 18.0 kg per carton

Outside dimension of carton: : 580mm*275mm*385mm

Pallet size : 1140mm*1180mm*132mm

Box stacked

By air_max : (2 *4) *3 layers , one pallet put 24 boxes , total 168 pcs module

By sea_max : (2 *4) *3 layers + (2 *4) *1 layers ,total 224 pcs module

By sea_HQ_max : (2 *3) *3 layers+(2 *3) *2 layers, total 280 pcs module

9.3 Palletizing

	MAX SHIPPING BY AIR	MAX SHIPPING BY SEA	MAX SHIPPING BY SEA_HO
MODULE/CARTON	7	7	7
CARTON/LAYER	8	8	8
LAYER/PALLET	3	3+1	3+2
MODULE/PALLET	168	224	280
CARTON SIZE(MM)	580(L)*275(W)*385(H)	580(L)*275(W)*385(H)	580(L)*275(W)*385(H)
PALLET SIZE(MM)	1180(L)*1140(W)*132(H)	1180(L)*1140(W)*132(H)	1180(L)*1140(W)*132(H)
TOTAL PALLET HEIGHT(MM)	1287	1804	2189
TOTAL PALLET WEIGHT(KG)	447	602	750

ONE PALLET SHIPMENT EXAMPLE SHIPPING BY AIR USED

TWO PALLET'S SHIPMENT EXAMPLE SHIPPING BY SEA USED

TWO PALLET'S SHIPMENT EXAMPLE SHIPPING BY SEA_HO USED



Product Specification

G215HAN01.0

AU OPTRONICS CORPORATION

10.0 Mechanical Characteristics

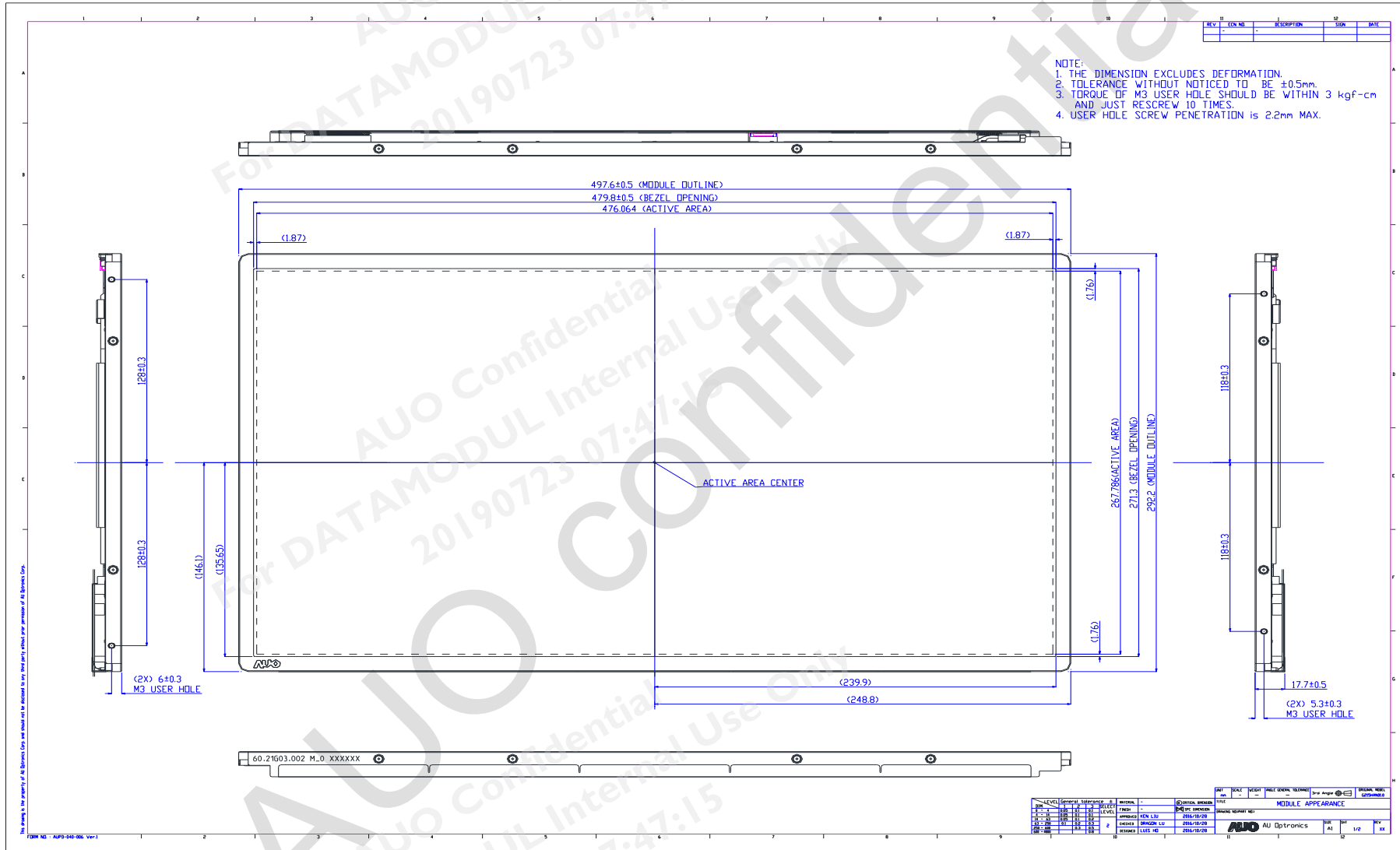

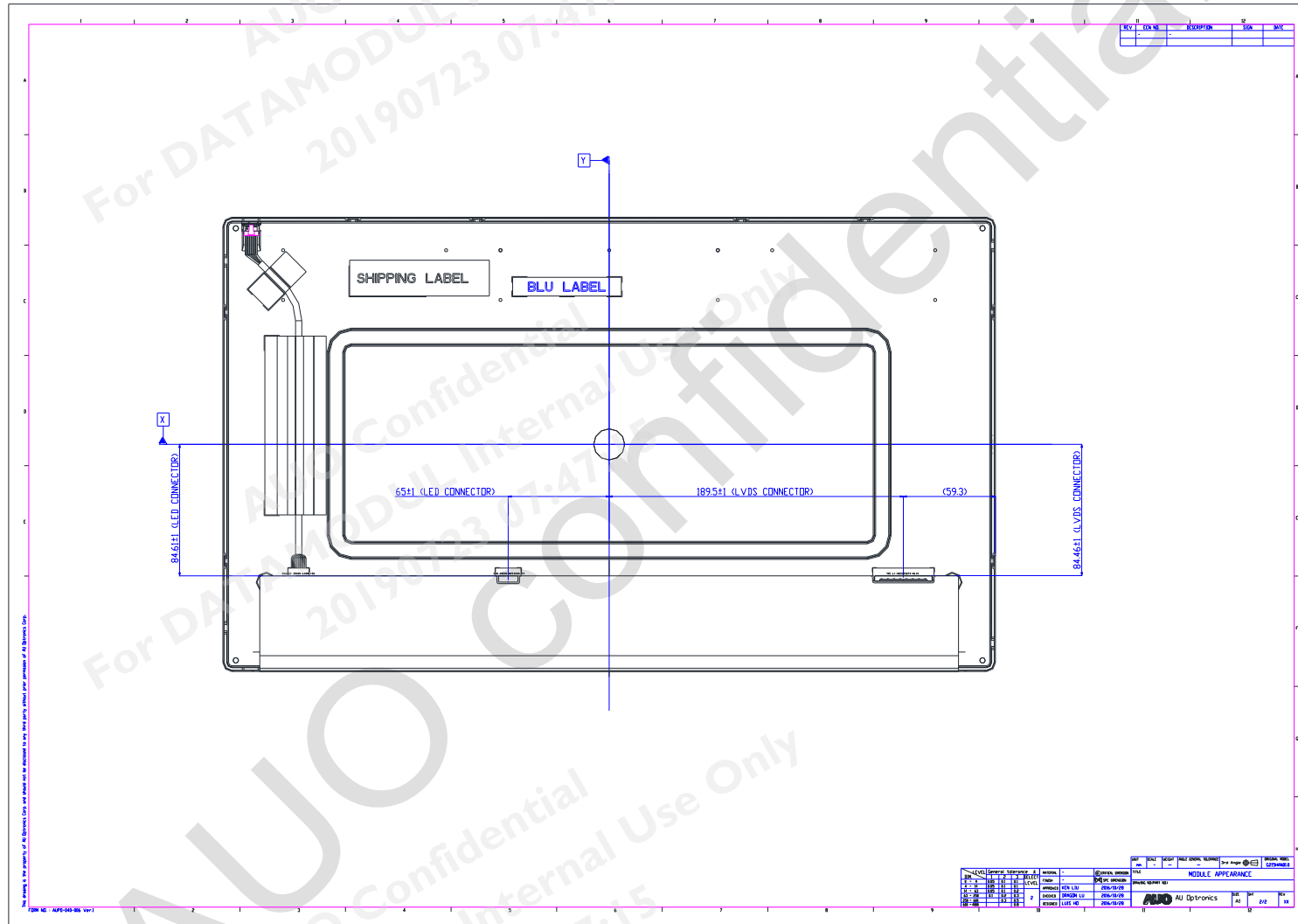

11 Safety

11.1 Sharp Edge Requirements

There will be no sharp edges or comers on the display assembly that could cause injury.

11.2 Materials

11.2.1 Toxicity

There will be no carcinogenic materials used anywhere in the display module. If toxic materials are used, they will be reviewed and approved by the responsible AUO toxicologist.

11.2.2 Flammability

All components including electrical components that do not meet the flammability grade UL94-V1 in the module will complete the flammability rating exception approval process.

The printed circuit board will be made from material rated 94-V1 or better. The actual UL flammability rating will be printed on the printed circuit board.

11.3 Capacitors

If any polarized capacitors are used in the display assembly, provisions will be made to keep them from being inserted backwards.

11.4 National Test Lab Requirement

The display module will satisfy all requirements for compliance to:

UL 60950-1, Second Edition

U.S.A. Information Technology Equipment



ALL TECHNOLOGIES. ALL COMPETENCIES. ONE SPECIALIST.

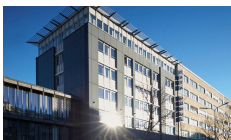

DATA MODUL AG
Landsberger Straße 322
DE-80687 Munich
Phone: +49-89-56017-0

DATA MODUL WEIKERSHEIM GMBH
Lindenstraße 8
DE-97990 Weikersheim
Phone: +49-7934-101-0



More information and worldwide locations can be found at

www.data-modul.com