

TO : Customer

DATE : 2014.10.01

**GREEN C&C TECH Co.,Ltd
65,JINWISANDAN-RO , JINWI-MYEON
PYEONGTAEK-CITY, KYEONGGI-DO
KOREA 451-861
TEL : 82-31-373-3623~3625
FAX : 82-31-373-3610**

DOCUMENTATION FOR APPROVAL

**PRODUCT : LED BACKLIGHT DRIVER (RoHS)
MODEL NAME : GH523A(A2)
GCCT NAME : GCCT523AC**

APPROVAL	CHECKED	WRITTEN

PLEASE RETURN ONE DOCUMENT AFTER APPROVED SIGN.

GREEN C&C TECH	LED DRIVER SPECIFICATION GH523A(A2)	Publishing Date	2013.04.11
		Reforming Date	2017.01.04

NO	Date	REVISION	Page
1	2014.10.01	1. Add a publication number on label	5
		2. Add a FUSE vendor - 453004 (LITTELFUSE)	7,14
		3. PCB vendor Changed - SEOKANG, WONKYUNG, BACKSONG, TAESUNG HITECH -> SEOKANG, WONKYUNG, JDM	7,14
2	2017.01.04	1. Add a Diode Vendor - D1 : B290 (LITEON), B2100 (LITEON)	6

REVISION HISTORY

REV.														
Page														
REV.	2	0	0	0	1	1	1	0	0	0	0	0	0	1
Page	1	2	3	4	5	6	7	8	9	10	11	12	13	14
Page Rev.											2	Page		1

GREEN C&C TECH	LED DRIVER SPECIFICATION GH523A(A2)	Publishing Date	2013.04.11
		Reforming Date	

1. APPLICATION

This Document Specified The Detailed Product Requirement of LED driver
GH523A(A2)

2. SUITABLE LOAD

LCD MODULE : 4 Strings LED BLU TFT LCD

3. ELECTRICAL CHARATERISTICS

3.1. Absolute Maximum Ratings

Item	Symbol	Spec.	Unit	Remarks
Input Voltage 1	Vin	10.8~26.4	V	
Input Voltage 2	ON/OFF	5.25	V	
Operating Temperature	Top	-20~70	℃	
Storage Temperature	Tstg	-30~80	℃	
Relative Humidity	RH	80	%	

3.2. Control Signal

PIN No.	Symbol	Status	Action	Remarks
CN1 #9	ON/OFF	HIGH	LED - ON	2.4 ~ 5.25V
		LOW	LED - OFF	0.8 V Max

GREEN C&C TECH	LED DRIVER SPECIFICATION GH523A(A2)	Publishing Date	2013.04.11
		Reforming Date	

3.3. Output Characteristics

Item	Sym.	Condition	Min.	Typ.	Max.	Unit
Input Voltage	Vin	-	10.8	-	26.4	Vdc
Input Current	Iin	Vin=12V, Dim=0V	-	-	1.5	A
Output Current	Iout (Max)	Vin=12V, Dim=0V	60.0	65.0	70.0	mAmean
	Iout (Min)	Vin=12V, Dim=5V	13.5	18.5	23.5	
Backlight ON/OFF Control	ON	-	2.4	-	5.25	Vdc
	OFF	-	-0.3	-	0.8	

3.4. Test Circuit

-. S/W : A --> BLU ON
B --> BLU OFF

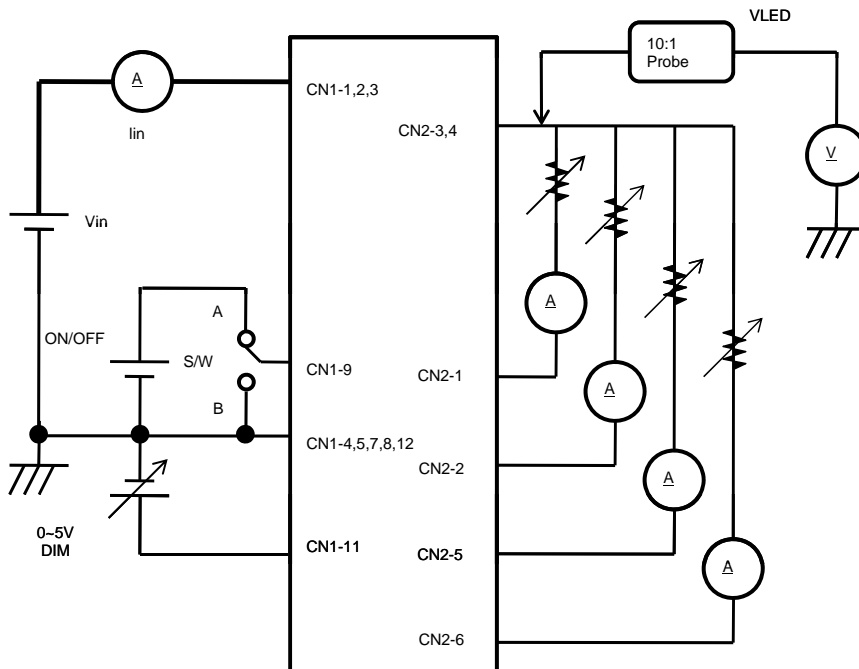

GREEN C&C TECH	LED DRIVER SPECIFICATION GH523A(A2)	Publishing Date Reforming Date	2013.04.11
----------------	--	-----------------------------------	------------

4. INTERFACE

4.1. CN1 Connector (Input) : 12505WR-12A (YEONHO) or Equivalent

PIN No.	Symbol	Description
1,2,3	VIN	Voltage Input : 12V, 24V (Typ.)
4,5,7,8,10,12	GND	Ground
6	N.C	No Connection
9	ON/OFF	LED DRIVER ON/OFF Control
11	DIM	0V(MAX) ~ 5V(MIN)

4.2. CN2 Connector (Output) : 12507WR-06L (YEONHO) or Equivalent

PIN No.	Symbol	Description
1	FB1	Feedback 1 (Return 1)
2	FB2	Feedback 2 (Return 2)
3	VLED	System Output
4	VLED	System Output
5	FB3	Feedback 3 (Return 3)
6	FB4	Feedback 4 (Return 4)

GREEN C&C TECH	LED DRIVER SPECIFICATION GH523A(A2)	Publishing Date	2013.04.11
		Reforming Date	2014.10.01

5. APPERANCE (Unit : mm)

(Tolerance : +0.8mm, -0.2mm)

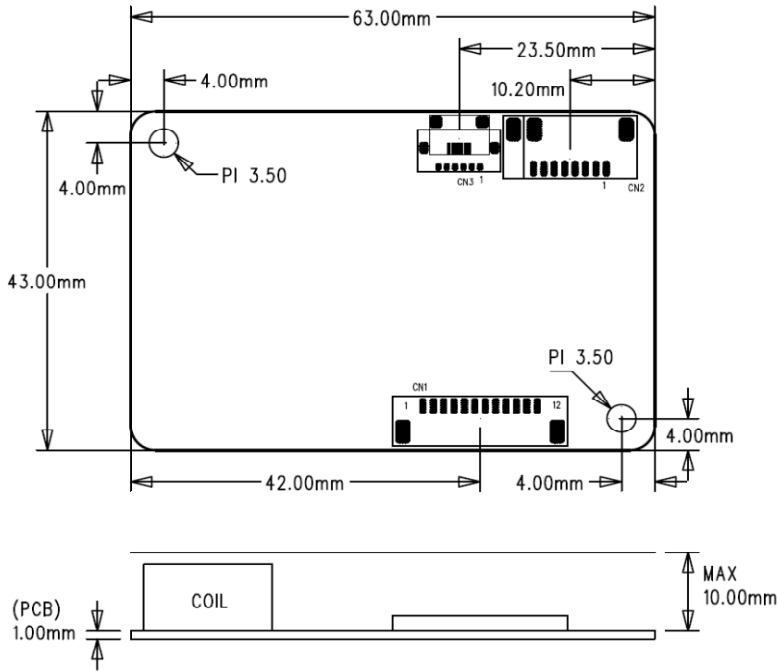

6. NOTATION OF LOT NUMBER

MARKING : BOTTOM



GH523A(A2)	: USER MODEL CODE
G	: MANUFACTURER CODE (GREEN C&C TECH.)
4	: YEAR OF PRODUCT 4 → 2014 , 5 → 2015 , ... , 9 → 2019
02	: WEEK OF PRODUCT 01,02,03,04,...52
A	: PUBLICATION NUMBER A,B,C,...,Z,0,1,2,...,9
0001	: SERIAL NUMBER 0001,0002.....9998,9999
AC	: GCCT MODEL CODE (GCCT523AC)

GREEN C&C TECH	LED DRIVER SPECIFICATION GH523A(A2)	Publishing Date	2013.04.11
		Reforming Date	2017.01.04

7. PART LIST

SYMBOL	NAME	1st		2nd	
		TYPE No	MAKER	TYPE No	MAKER
U1	IC	MP3391EF	MPS		
Q1	FET	AP9997GH	APEC	MDD1903RH	MAGNACHIP
		AOD478	AOS	AM20N10	Analog Power
		APM1110NUA3	ANPEC		
Q2	TR	SST2907A	ROHM	KTN2907AS	KEC
		MMBT2907A	DIODES	SBT2907A	AUK
		MMBT2907A	PANJIT	MMBT2907ALT1G	ONSEMI
D1	DIODE	B290	DIODES	B2100	DIODES
		MB29	PANJIT	MB210	PANJIT
		SS29	TSC	SS210	TSC
		B290	LITEON	B2100	LITEON
C1	C-ELEC	NXH Series 220uF/35V	SAMYOUNG	Equivalent	
C16		NXA Series 15uF/100V	SAMYOUNG	"	
C2,C4	MLCC	GRM21BR61E225K	MURATA	Equivalent	
C3		GRM21BR71H105K	"	"	
C5,C6,C8		GRM188R71C105K	"	"	
C7		GRM188R71H103K	"	"	
C9		GRM188R71H104K	"	"	
C14		GRM1885C1H101J	"	"	
C15		GRM31CR72A105K	"	"	
R1		CHIP-R	MCR10EZPJ100	ROHM	Equivalent
R3,R12	MCR03EZPJ224		"	"	
R4,R5	MCR03EZPJ513		"	"	
R6,R9,R18, R21,R22	MCR03EZPJ104		"	"	
R7	MCR03EZPJ134		"	"	
R10	MCR03EZPJ273		"	"	
R11	MCR03EZPJ102		"	"	
R13	MCR03EZPJ184		"	"	
R14	MCR03EZPJ393		"	"	
R15	MCR03EZPJ303		"	"	
R16	MCR03EZPJ101		"	"	
R17	MCR03EZPJ100		"	"	
R23	MCR03EZPJ472		"	"	
R19,R20	MCR18EZHFLR200		"	"	

GREEN C&C TECH	LED DRIVER SPECIFICATION GH523A(A2)	Publishing Date	2013.04.11
		Reforming Date	2014.10.01

SYMBOL	NAME	1st		2nd	
		TYPE No	MAKER	TYPE No	MAKER
F1	FUSE	CCF1N4	KOA	CB61F4A	Cooper Bussmann
		451004	LITTELFUSE	453004	LITTELFUSE
L1	Inductor	SPI-1260SDN-470	SEJIN	Equivalent	
L2		SPI-3516RS-100	SEJIN	"	
CN1	Connector	12505WR-12A	YEONHO	Equivalent	
CN2		12507WR-06L	YEONHO	"	
PCB	PCB	GH523A REV1.0	SEOKANG	GH523A REV1.0	WONKYUNG
		GH523A REV1.0	JDM		

GREEN C&C TECH	LED DRIVER SPECIFICATION GH523A(A2)	Publishing Date Reforming Date	2013.04.11
----------------	--	-----------------------------------	------------

8. PCB LAYOUT

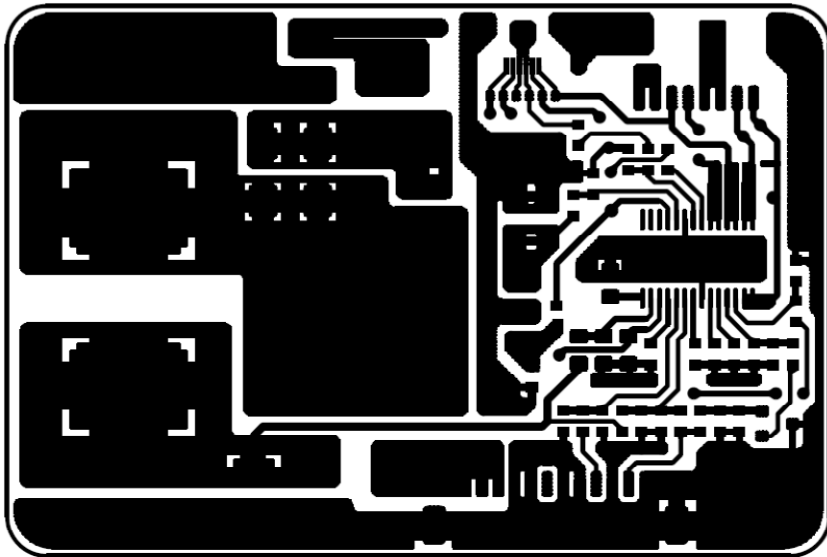

TOP LAYER

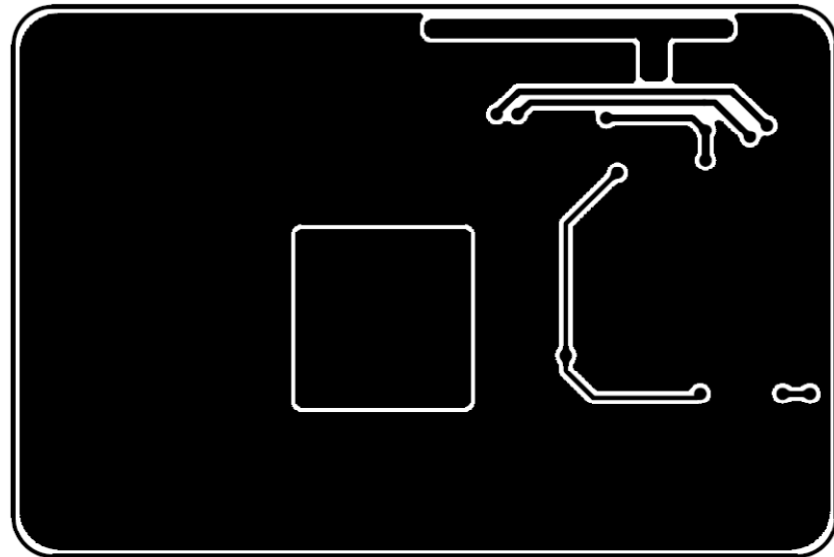

BOTTOM LAYER

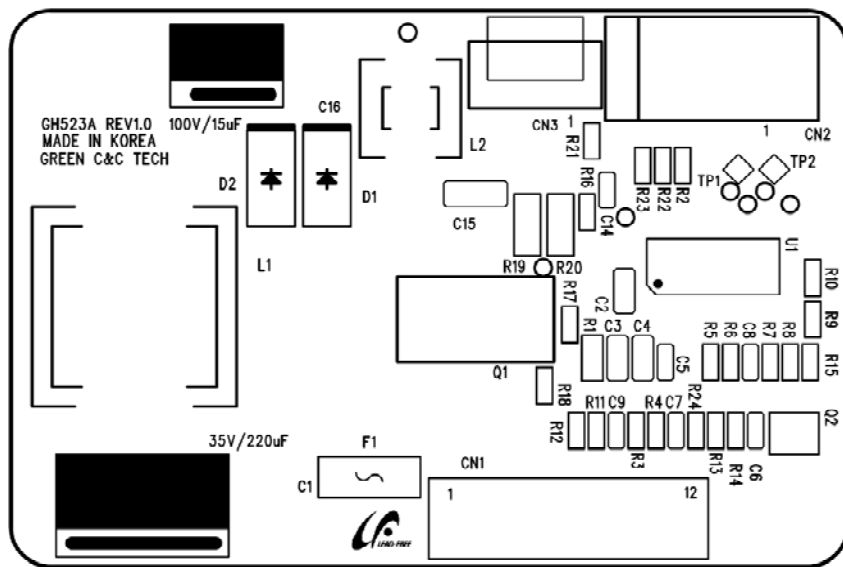

SILK SCREEN TOP

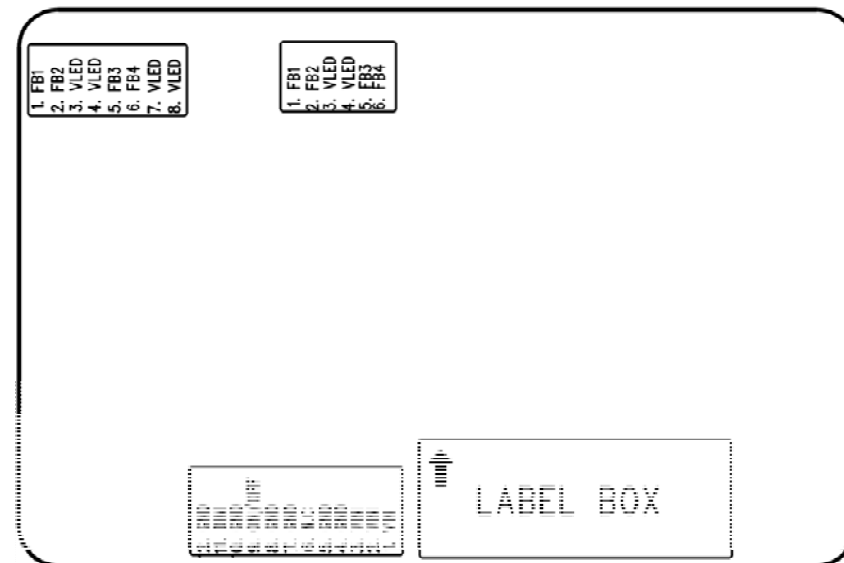

SILK SCREEN BOTTOM

9. CIRCUIT

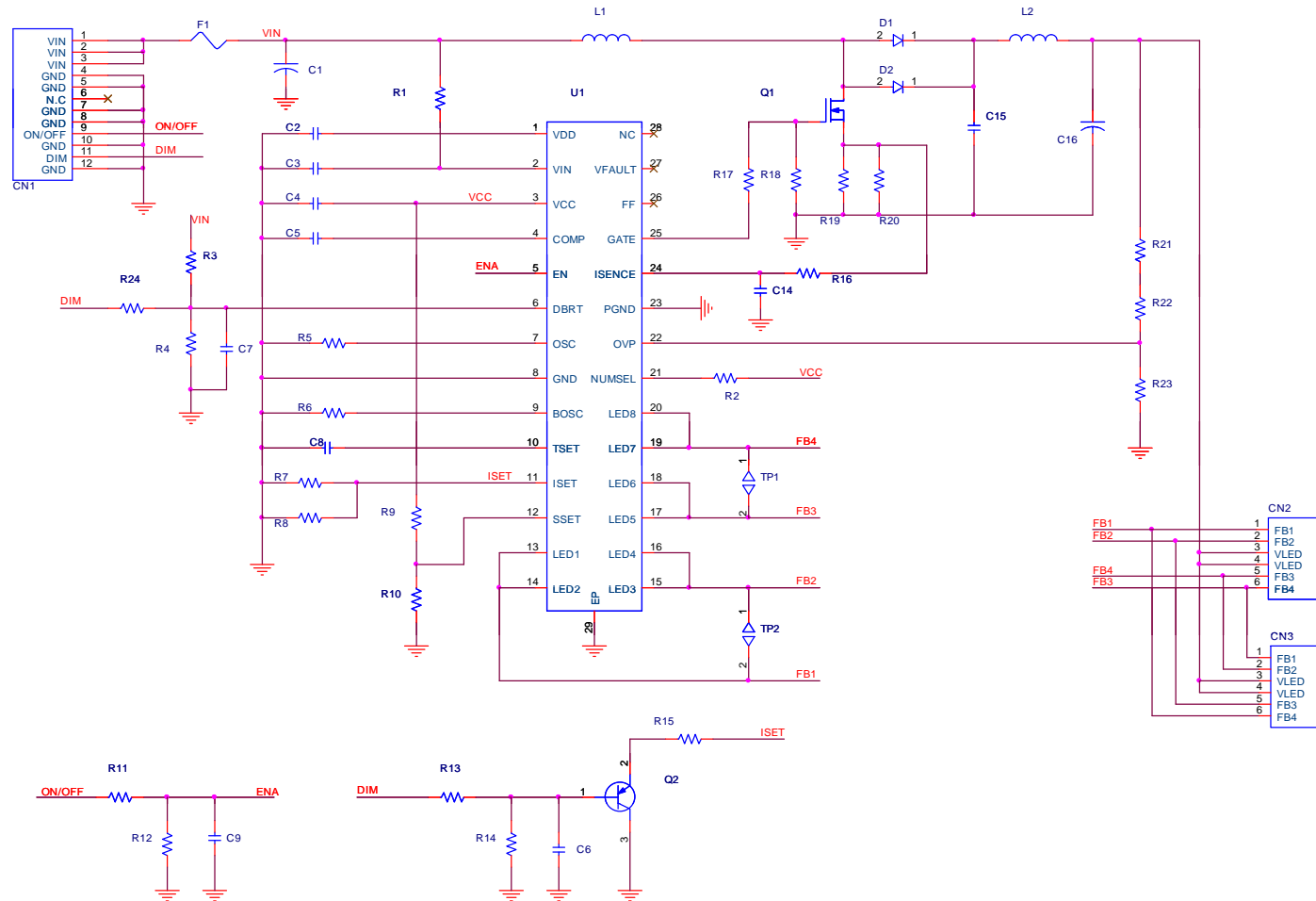

GREEN C&C TECH	LED DRIVER SPECIFICATION GH523A(A2)	Publishing Date Reforming Date	2013.04.11
----------------	--	-----------------------------------	------------

10. RELIABILITY TEST SPEC.

NO.	ITEM	Conditions and Method
1	High Temperature Storage Test	Temp : 85 °C Duration : 250hrs
2	Low Temperature Storage Test	Temp : -40 °C Duration : 250hrs
3	High Temperature High Humidity Operation Test	Temp : 70 °C Humidity : 95%RH Duration : 250hrs
4	Signal On/Off Test	Temp : Normal Temperature On-Off Signal On 10sec / Off 10sec Power on full Load 30,000 cycles
5	Thermal Shock Test	Temp : -40 °C ↔ 100 °C, 100 cycles (30min) (30min)
6	High Temperature Operation Test	Temp : 70 °C Duration : 250hrs
7	Low Temperature Operation Test	Temp : -20 °C Duration : 250hrs

GREEN C&C TECH	LED DRIVER SPECIFICATION GH523A(A2)	Publishing Date	2013.04.11
		Reforming Date	





11. FLOW CHART

MODEL (TYPE)	GH523A(A2)	REVISION	5
WRITER	D.J.YOON	FLOW CHART	
FLOW CHART	PROCESS	EQUIPMENTS	Remark
	Raw Material		PART LIST
	Solder Printing	Cream-solder Printer	
	Surface Mounting	Low-high Mounter	
	Reflow Soldering (CTQ)	Reflower	
	Visual Inspection (AOI)	Microscope, Vision-Master	
	Label attachment	Marking	
	Preparing Process		
	Soldering by Hand for Discrete Parts		
	Spreading Silicon	Silicon Dispenser	
	Insert Lead Parts		
	Wave-Soldering	Wave-Soldering Machine	
	Visual Inspection		
	PCB Division		
	Aging	Power Supply, Aging Box	2hrs
	Electrical Characteristics inspection	Testing System, Testing JIG	
	Insulator Attachment		
	Bar-Code Reading	Bar-Code Reader	
	Package		
	Outgoing Inspection	Testing System, Testing JIG	List of Inspection
	Shipping		
Based on Standard Rule	GCCT523AC		

GREEN C&C TECH	LED DRIVER SPECIFICATION GH523A(A2)	Publishing Date	2013.04.11
		Reforming Date	

12. PACKING

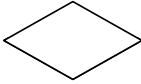
12.1. BOX

 LEAD-FREE			 L/C NO : C/T NO : MADE IN KOREA
1. Customer			
2. PART NAME	GH523A(A2)		
3. PO NO			
4. Q'ty	000 EA		
5. Date	00.00.00		
6. LOT NO			

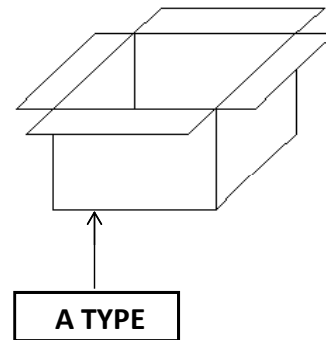

12.2. TRAY

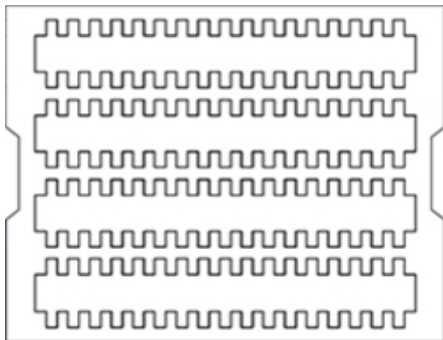

SYMBOL	TYPE NO
PACKING-TRAY	393*324*53
PACKING-BOX	415*340*332
PACKING-PAD	393*324*3

1 TRAY : 68EA (GR2052)
 1BOX : 6 TRAY (408EA) - A TYPE

GREEN C&C TECH	LED DRIVER SPECIFICATION GH523A(A2)	Publishing Date	2013.04.11
		Reforming Date	2014.10.01

13. Material list for safety GH523A(A2)

SYMBOL	NAME	TYPE No	MANUFACTURER	DESCRIPTION
F1	FUSE	CCF1N4	KOA	UL FILE NO. : E171861
		451004	LITTELFUSE	UL FILE NO. : E10480
		453004		CSA FILE NO : LR29862
		CB61F4A	COOPER BUSSNANN	UL FILE NO. : E19180
PCB	Printed Writing Board	FR4	SEOKANG	UL FILE NO. : E150774
			WONKYUNG	UL FILE NO. : E202541
			JDM	UL FILE NO. : E343057
CN1	Connector	12505WR-12A	YEONHO	UL FILE NO. : E108706
CN2	Connector	12507WR-06L	YEONHO	UL FILE NO. : E108706