



SPECIFICATION

INNOLUX

G238HCJ-LH1

23.8" – FHD – LVDS

Version: 2.1

Date: 06.01.2023

Note: This specification is subject to change without prior notice

- Tentative Specification
- Preliminary Specification
- Approval Specification

MODEL NO.: G238HCJ
SUFFIX: LH1

Customer:	
APPROVED BY	SIGNATURE
Name / Title	_____
Note	

Please return 1 copy for your confirmation with your signature and comments.	

Approved By	Checked By	Prepared By
林秋森	吳承旻	許文進

CONTENTS

1. GENERAL DESCRIPTION	5
1.1 OVERVIEW	5
1.2 FEATURE	5
1.3 APPLICATION	5
1.4 GENERAL SPECIFICATIONS	5
1.5 MECHANICAL SPECIFICATIONS	5
2. ABSOLUTE MAXIMUM RATINGS	6
2.1 ABSOLUTE RATINGS OF ENVIRONMENT	6
2.2 ELECTRICAL ABSOLUTE RATINGS	7
2.2.1 TFT LCD MODULE	7
2.2.2 BACKLIGHT UNIT	7
3. ELECTRICAL CHARACTERISTICS	8
3.1 TFT LCD MODULE	8
3.2 BACKLIGHT UNIT	9
4. BLOCK DIAGRAM	11
4.1 TFT LCD MODULE	11
5. INPUT TERMINAL PIN ASSIGNMENT	12
5.1 TFT LCD MODULE (VESA ONLY).....	12
5.2 BACKLIGHT UNIT(Converter connector pin).....	13
5.3 COLOR DATA INPUT ASSIGNMENT	14
6. INTERFACE TIMING	15
6.1 INPUT SIGNAL TIMING SPECIFICATIONS	15
6.2 POWER ON/OFF SEQUENCE.....	17
7. OPTICAL CHARACTERISTICS	19
7.1 TEST CONDITIONS	19
7.2 OPTICAL SPECIFICATIONS	19
8. RELIABILITY TEST CRITERIA	22
9. PACKAGING.....	23
9.1 PACKING SPECIFICATIONS	23
9.2 PACKING METHOD	23
9.3 UN-PACKING METHOD	25
10. DEFINITION OF LABELS.....	26
10.1 INX MODULE LABEL	26
11. PRECAUTIONS	27
11.1 ASSEMBLY AND HANDLING PRECAUTIONS.....	27
11.2 STORAGE PRECAUTIONS.....	27
11.3 OTHER PRECAUTIONS.....	28

12. MECHANICAL CHARACTERISTICS 29
Appendix. SYSTEM COVER DESIGN NOTICE 31

REVISION HISTORY

Version	Date	Page	Description
2.0	2022.10	All	Approval Specification was first issued.
2.1	2023,01	22	8. RELIABILITY TEST CRITERIA To modify the Low Temperature Storage Test as -30°C . To modify the Thermal Shock Storage Test as -20°C ~60°C .
		28	11.3 OTHER PRECAUTIONS To remove two terms (a) & (c)

1. GENERAL DESCRIPTION

1.1 OVERVIEW

G238HCJ-LH1 is a 23.8" TFT Liquid Crystal Display IAV module with WLED Backlight unit and 30 pins 2ch-LVDS interface. This module supports 1920 x 1080 Full HD mode and can display up to 16.7M colors. The converter module for Backlight is built in.

1.2 FEATURE

- FHD (1920 x 1080 pixels) resolution
- Wide operating temperature.
- RoHS compliance

1.3 APPLICATION

- TFT LCD Monitor
- Factory Application

1.4 GENERAL SPECIFICATIONS

Item	Specification	Unit	Note
Active Area	527.04 (H) x 296.46 (V)	mm	(1)
Driver Element	a-Si TFT active matrix	-	-
Pixel Number	1920 x R.G.B x 1080	pixel	-
Pixel Pitch	0.2745 (H) x 0.2745 (V)	mm	-
Pixel Arrangement	RGB vertical Stripe	-	-
Display Colors	16.7M / 262K	color	-
Display Mode	Normally Black	-	-
Surface Treatment	AG type, 3H hard coating, Haze 25	-	-
Module Power Consumption	34.95	W	Typ.

1.5 MECHANICAL SPECIFICATIONS

Item		Min.	Typ.	Max.	Unit	Note
Module Size	Horizontal(H)	542.5	543	543.5	mm	(1)
	Vertical(V)	316.9	317.4	317.9	mm	
	Depth(D)	18.925	19.425	19.925	mm	
Bezel Area	Horizontal	529.7	530.2	530.7	mm	-
	Vertical	299.1	299.6	300.1	mm	
Active Area	Horizontal	--	527.04	--	mm	
	Vertical	--	296.46	--	mm	
Weight		-	2820	--	g	

Note (1)Please refer to the attached drawings for more information of front and back outline dimensions.

2. ABSOLUTE MAXIMUM RATINGS

2.1 ABSOLUTE RATINGS OF ENVIRONMENT

Item	Symbol	Value		Unit	Note
		Min.	Max.		
Operating Ambient Temperature	T _{OP}	-30	+80	°C	(1)(2)
Storage Temperature	T _{ST}	-30	+80	°C	

Note (1)

- (a) 90 %RH Max.
- (b) Wet-bulb temperature should be 39 °C Max.
- (c) No condensation.

Note (2) Any condition of ambient operating temperature ,the surface of active area should be keeping not higher than 80°C (Panel surface temperature) .

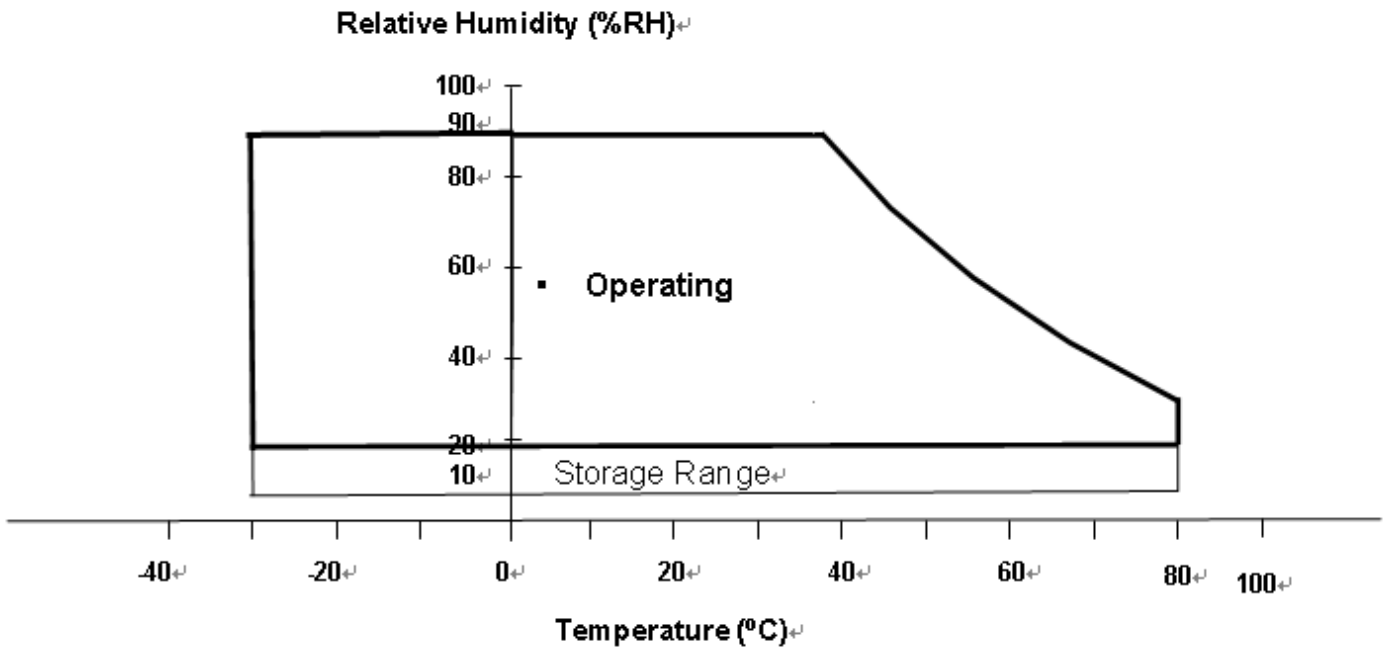

2.2 ELECTRICAL ABSOLUTE RATINGS

2.2.1 TFT LCD MODULE

Item	Symbol	Value		Unit	Note
		Min.	Max.		
Power Supply Voltage	VCC	-0.3	6.0	V	(1)
Logic Input Voltage	V _{IN}	-0.3	3.6	V	

2.2.2 BACKLIGHT UNIT

Item	Symbol	Value		Unit	Note
		Min.	Max.		
Converter Voltage	V _i	-0.3	26.4	V	(1), (2)
Enable Voltage	EN	-0.3	5.5	V	
Backlight Adjust	Dimming	-0.3	5.5	V	

Note (1) Permanent damage to the device may occur if maximum values are exceeded. Function operation should be restricted to the conditions described under Normal Operating Conditions.

Note (2) Specified values are for LED (Refer to 3.2 for further information).

3. ELECTRICAL CHARACTERISTICS

3.1 TFT LCD MODULE

Parameter	Symbol	Value			Unit	Note	
		Min.	Typ.	Max.			
Power Supply Voltage	V_{CC}	4.5	5.0	5.5	V	-	
Ripple Voltage	V_{RP}	-	-	400	mVp-p		
Inrush Current	I_{INRUSH}	-	-	3.0	A	(2)	
Power Supply Current	White	-	0.99	1.45	A	(3)a	
	Black	-	0.45	0.5	A	(3)b	
	Vertical Stripe	-	0.74	0.81	A	(3)c	
LVDS differential input voltage	V_{id}	100	-	600	mV		
LVDS common input voltage	V_{ic}	1.0	1.2	1.4	V		
Differential Input Voltage for LVDS Receiver Threshold	"H" Level	V_{IH}	-	-	100	mV	-
	"L" Level	V_{IL}	-100	-	-	mV	-
Terminating Resistor	R_T	-	100	-	Ohm	-	

Note (1)The module should be always operated within above ranges.

Note (2)Measurement Conditions:

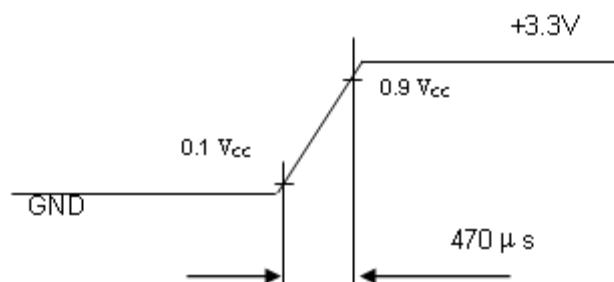
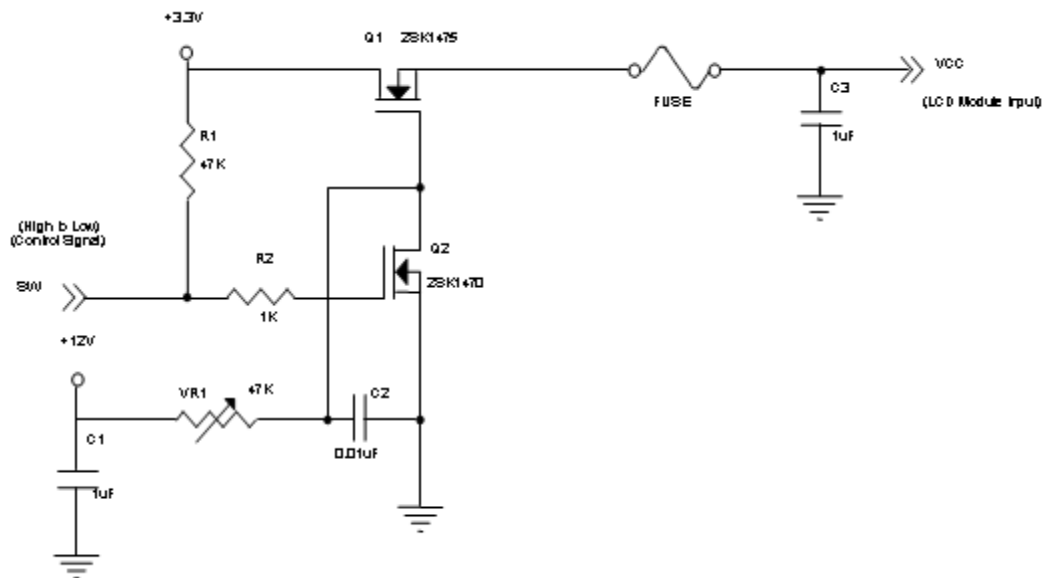

Note (3) The specified power supply current is under the conditions at $V_{DD} = 3.3V$, $T_a = 25 \pm 2^\circ C$, DC Current and $f_v = 60$ Hz, whereas a power dissipation check pattern below is displayed.

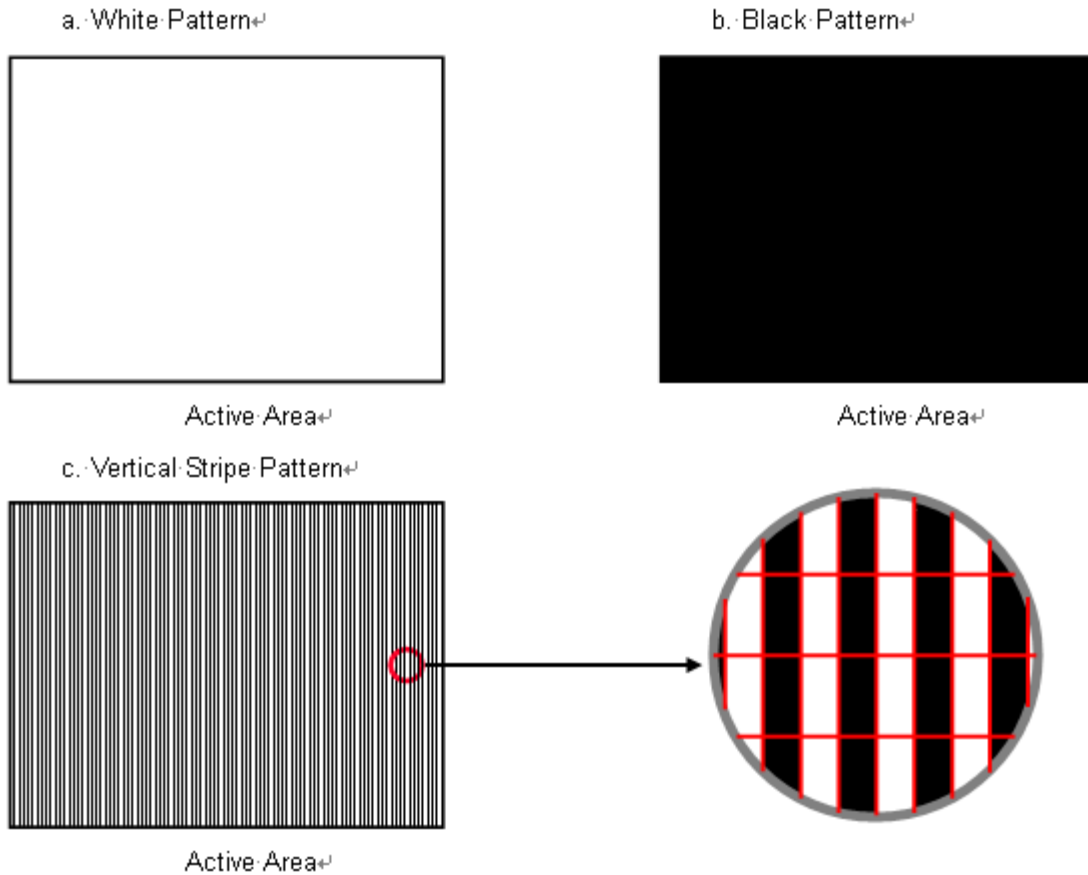

3.2 BACKLIGHT UNIT

Parameter	Symbol	Value			Unit	Note	
		Min.	Typ.	Max.			
Converter Input Voltage	V_i	21.6	24.0	26.4	V_{DC}	(Duty 100%)	
Converter Input Ripple Voltage	V_{iRP}	-	-	500	mV		
Converter Input Current	I_i	-	1.25	1.5	A_{DC}	@ $V_i = 24V$ (Duty 100%)	
Converter Inrush Current	I_{iRUSH}	-	-	3.0	A	@ V_i rising time=20ms ($V_i=24V$)	
Input Power Consumption	P_i	-	30	36	W	(1), @ $V_i = 24V$ (Duty 100%)	
EN Control Level	Backlight on	ENLED	2.5	3.3	5.0	V	
	Backlight off	(BLON)	0	-	0.3	V	
PWM Control Level	PWM High Level	Dimming	2.5	3.3	5.0	V	
	PWM Low Level	(E_PWM)	0	-	0.15	V	
PWN Noise Range	V_{Noise}	-	-	0.1	V		
PWM Control Frequency	f_{PWM}	100	200	1,000	Hz	(2), Suggestion@200Hz	
PWM Dimming Control Duty Ratio	-		5	-	100	%	(2), @ 100Hz < f_{PWM} < 500Hz
			10	-	100	%	(2), @ 500Hz \leq f_{PWM} < 1kHz
LED Life Time	L_{LED}	50,000		-	Hrs	(3)	

Note (1) LED current is measured by utilizing a high frequency current meter as shown below:

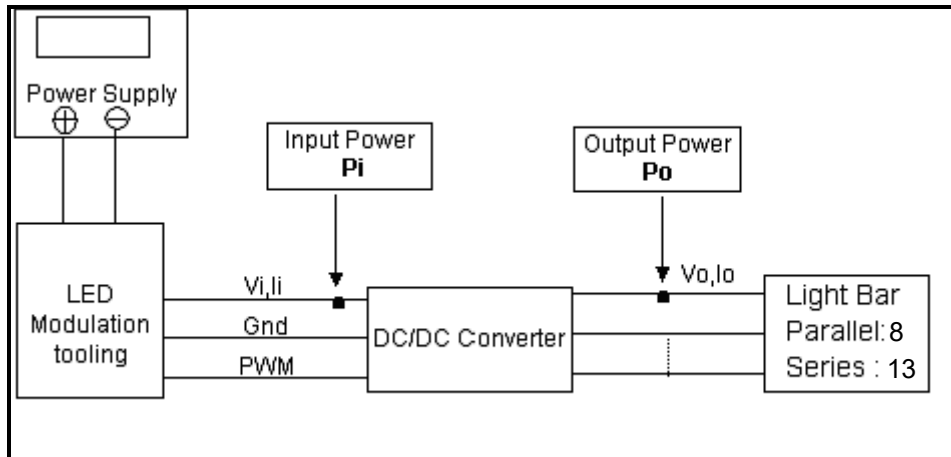

Note (2) At 100 ~499Hz PWM control frequency, duty ratio range is restricted from 5% to 100%.
 At 500 ~1kHz PWM control frequency, duty ratio range is restricted from 10% to 100%
 If PWM control frequency is applied in the range 1KHZ above, The “non-linear” phenomenon on the Backlight Unit may be found. So It’s a suggestion that PWM control frequency should be less than 1KHz.

Note (3) The lifetime of LED is estimated data and defined as the time when it continues to operate under the conditions at $T_a = 25 \pm 2 \text{ }^\circ\text{C}$ and Duty 100% until the brightness becomes $\leq 50\%$ of its original value.
 Operating LED at high temperature condition will reduce life time and lead to color shift.

Note (4) De-rating Curve

De-rating the BLU from 70°C and 50% PWM at 80°C to avoid damaging the module.

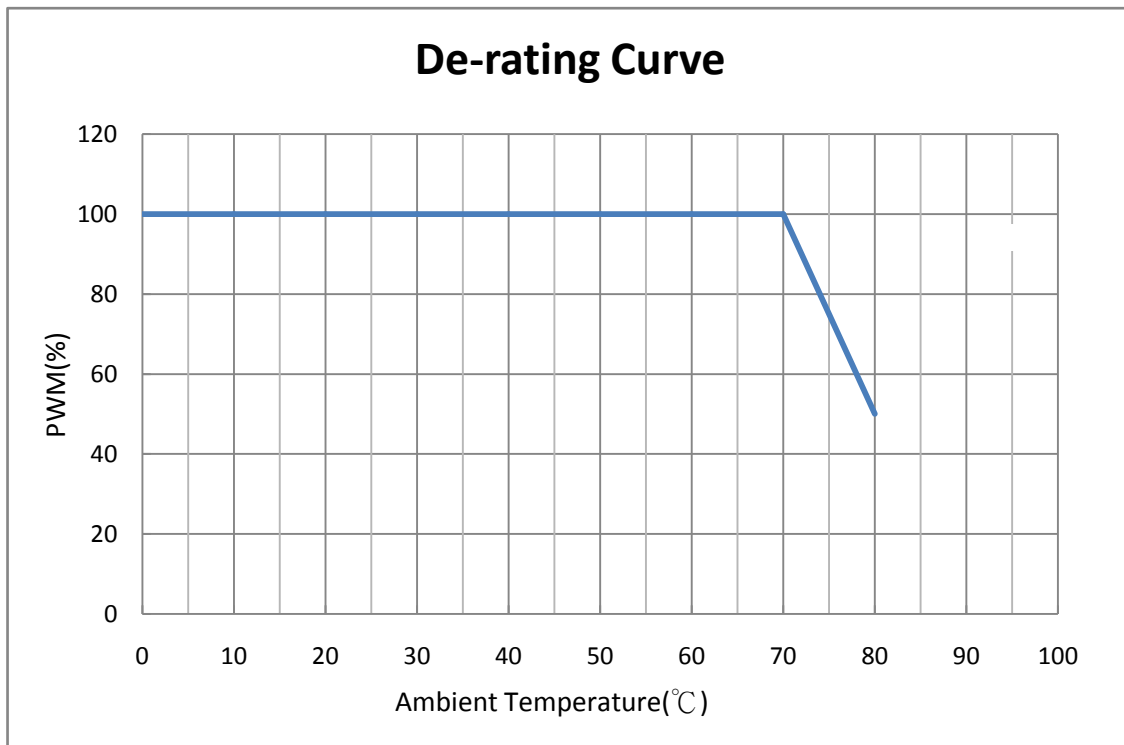

4. BLOCK DIAGRAM

4.1 TFT LCD MODULE

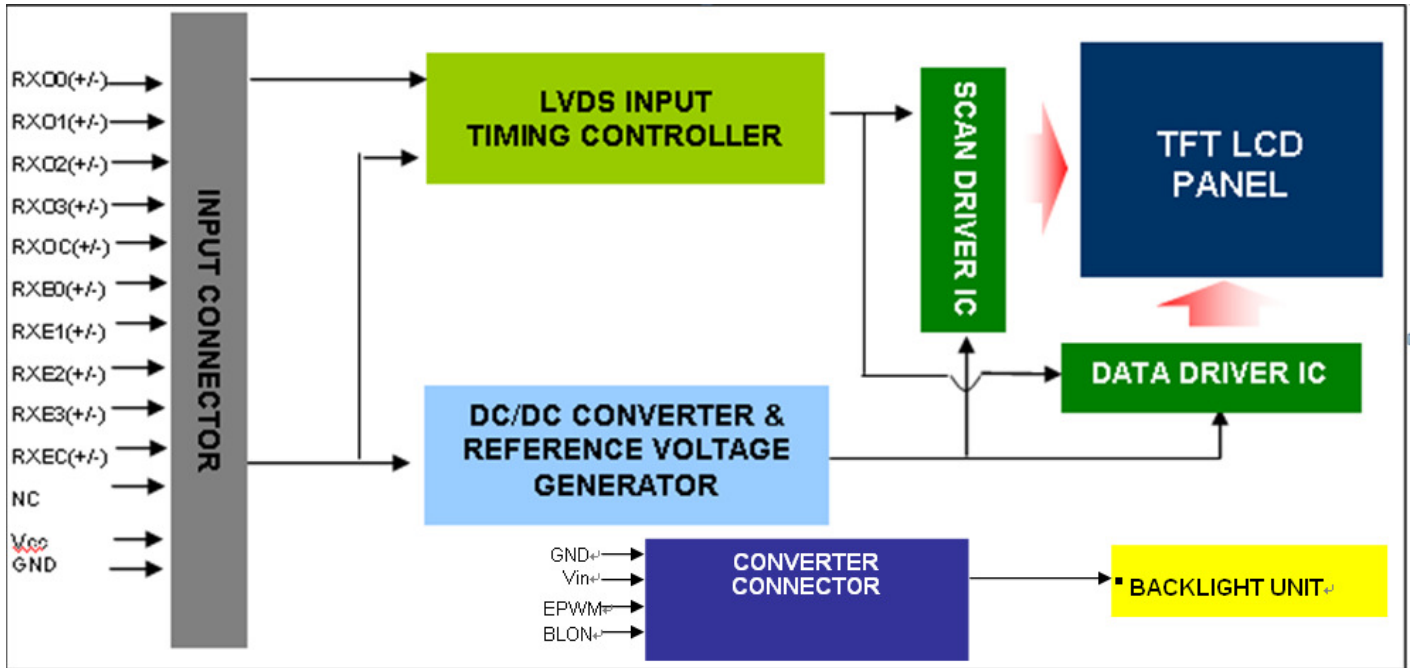

5. INPUT TERMINAL PIN ASSIGNMENT

5.1 TFT LCD MODULE (VESA ONLY)

Pin	Name	Description
1	RXO0-	Negative LVDS differential data input. Channel O0 (odd)
2	RXO0+	Positive LVDS differential data input. Channel O0 (odd)
3	RXO1-	Negative LVDS differential data input. Channel O1 (odd)
4	RXO1+	Positive LVDS differential data input. Channel O1 (odd)
5	RXO2-	Negative LVDS differential data input. Channel O2 (odd)
6	RXO2+	Positive LVDS differential data input. Channel O2 (odd)
7	GND	Ground
8	RXOC-	Negative LVDS differential clock input. (odd)
9	RXOC+	Positive LVDS differential clock input. (odd)
10	RXO3-	Negative LVDS differential data input. Channel O3(odd)
11	RXO3+	Positive LVDS differential data input. Channel O3 (odd)
12	RXE0-	Negative LVDS differential data input. Channel E0 (even)
13	RXE0+	Positive LVDS differential data input. Channel E0 (even)
14	GND	Ground
15	RXE1-	Negative LVDS differential data input. Channel E1 (even)
16	RXE1+	Positive LVDS differential data input. Channel E1 (even)
17	GND	Ground
18	RXE2-	Negative LVDS differential data input. Channel E2 (even)
19	RXE2+	Positive LVDS differential data input. Channel E2 (even)
20	RXEC-	Negative LVDS differential clock input. (even)
21	RXEC+	Positive LVDS differential clock input. (even)
22	RXE3-	Negative LVDS differential data input. Channel E3 (even)
23	RXE3+	Positive LVDS differential data input. Channel E3 (even)
24	GND	Ground
25	NC	For LCD internal use only, Do not connect
26	NC	For LCD internal use only, Do not connect
27	NC	For LCD internal use only, Do not connect
28	Vcc	+5.0V power supply
29	Vcc	+5.0V power supply
30	Vcc	+5.0V power supply

Note (1) Connector Part No.:

FCN: WF13-422-3033

P-TWO: 187098-30091 or equivalent.

Note (2) User's connector Part No:

Mating Wire Cable Connector Part No.: FI-X30H(JAE) or FI-X30HL(JAE)

Mating FFC Cable Connector Part No.: 217007-013001 (P-TWO) or JF05X030-1 (JAE).

Note (3) The first pixel is odd.

Note (4) Input signal of even and odd clock should be the same timing.

5.2 BACKLIGHT UNIT(Converter connector pin)

Pin	Name	Description
1	V _{BL}	DC 24V power supply
2		
3		
4		
5		
6	GND	Ground
7		
8		
9		
10		
11	NC	NC
12	EN	BL ON/OFF (ON:DC 3.3V, OFF:0V)
13	NC	NC
14	E_PWM	External PWM Control (H Level: DC 5V, L Level: 0V)

Note (1)Connector Part No.: CviLux :CI0114M1HR0-LA-NH or FCN: JH2-D4-143N or equivalent.

Note (2)User's connector Part No.: CviLux CI0114S0000 or equivalent.

5.3 COLOR DATA INPUT ASSIGNMENT

The brightness of each primary color (red, green and blue) is based on the 8-bit gray scale data input for the color. The higher the binary input the brighter the color. The table below provides the assignment of color versus data input.

Color		Data Signal																						
		Red								Green								Blue						
		R7	R6	R5	R4	R3	R2	R1	R0	G7	G6	G5	G4	G3	G2	G1	G0	B7	B6	B5	B4	B3	B2	B1
Basic Colors	Black	0	0	0	0	0	0	0	0	0	0	0	0	0	0	0	0	0	0	0	0	0	0	0
	Red	1	1	1	1	1	1	1	0	0	0	0	0	0	0	0	0	0	0	0	0	0	0	0
	Green	0	0	0	0	0	0	0	1	1	1	1	1	1	1	1	0	0	0	0	0	0	0	0
	Blue	0	0	0	0	0	0	0	0	0	0	0	0	0	0	0	1	1	1	1	1	1	1	1
	Cyan	0	0	0	0	0	0	0	1	1	1	1	1	1	1	1	1	1	1	1	1	1	1	1
	Magenta	1	1	1	1	1	1	1	0	0	0	0	0	0	0	0	1	1	1	1	1	1	1	1
	Yellow	1	1	1	1	1	1	1	1	1	1	1	1	1	1	1	0	0	0	0	0	0	0	0
	White	1	1	1	1	1	1	1	1	1	1	1	1	1	1	1	1	1	1	1	1	1	1	1
Gray Scale Of Red	Red(0) / Dark	0	0	0	0	0	0	0	0	0	0	0	0	0	0	0	0	0	0	0	0	0	0	
	Red(1)	0	0	0	0	0	0	1	0	0	0	0	0	0	0	0	0	0	0	0	0	0	0	
	Red(2)	0	0	0	0	0	0	1	0	0	0	0	0	0	0	0	0	0	0	0	0	0	0	
	⋮	⋮	⋮	⋮	⋮	⋮	⋮	⋮	⋮	⋮	⋮	⋮	⋮	⋮	⋮	⋮	⋮	⋮	⋮	⋮	⋮	⋮	⋮	
	⋮	⋮	⋮	⋮	⋮	⋮	⋮	⋮	⋮	⋮	⋮	⋮	⋮	⋮	⋮	⋮	⋮	⋮	⋮	⋮	⋮	⋮	⋮	
	Red(253)	1	1	1	1	1	1	0	1	0	0	0	0	0	0	0	0	0	0	0	0	0	0	
	Red(254)	1	1	1	1	1	1	1	0	0	0	0	0	0	0	0	0	0	0	0	0	0	0	
	Red(255)	1	1	1	1	1	1	1	1	0	0	0	0	0	0	0	0	0	0	0	0	0	0	
Gray Scale Of Green	Green(0)/Dark	0	0	0	0	0	0	0	0	0	0	0	0	0	0	0	0	0	0	0	0	0	0	
	Green(1)	0	0	0	0	0	0	0	0	0	0	0	0	0	0	1	0	0	0	0	0	0	0	
	Green(2)	0	0	0	0	0	0	0	0	0	0	0	0	0	1	0	0	0	0	0	0	0	0	
	⋮	⋮	⋮	⋮	⋮	⋮	⋮	⋮	⋮	⋮	⋮	⋮	⋮	⋮	⋮	⋮	⋮	⋮	⋮	⋮	⋮	⋮	⋮	
	⋮	⋮	⋮	⋮	⋮	⋮	⋮	⋮	⋮	⋮	⋮	⋮	⋮	⋮	⋮	⋮	⋮	⋮	⋮	⋮	⋮	⋮	⋮	
	Green(253)	0	0	0	0	0	0	0	1	1	1	1	1	1	0	1	0	0	0	0	0	0	0	
	Green(254)	0	0	0	0	0	0	0	1	1	1	1	1	1	1	0	0	0	0	0	0	0	0	
	Green(255)	0	0	0	0	0	0	0	1	1	1	1	1	1	1	1	0	0	0	0	0	0	0	
Gray Scale Of Blue	Blue(0) / Dark	0	0	0	0	0	0	0	0	0	0	0	0	0	0	0	0	0	0	0	0	0	0	
	Blue(1)	0	0	0	0	0	0	0	0	0	0	0	0	0	0	0	0	0	0	0	0	0	1	
	Blue(2)	0	0	0	0	0	0	0	0	0	0	0	0	0	0	0	0	0	0	0	0	0	1	
	⋮	⋮	⋮	⋮	⋮	⋮	⋮	⋮	⋮	⋮	⋮	⋮	⋮	⋮	⋮	⋮	⋮	⋮	⋮	⋮	⋮	⋮	⋮	
	⋮	⋮	⋮	⋮	⋮	⋮	⋮	⋮	⋮	⋮	⋮	⋮	⋮	⋮	⋮	⋮	⋮	⋮	⋮	⋮	⋮	⋮	⋮	
	Blue(253)	0	0	0	0	0	0	0	0	0	0	0	0	0	0	1	1	1	1	1	1	0	1	
	Blue(254)	0	0	0	0	0	0	0	0	0	0	0	0	0	0	1	1	1	1	1	1	1	0	
	Blue(255)	0	0	0	0	0	0	0	0	0	0	0	0	0	0	1	1	1	1	1	1	1	1	

Note (1)0: Low Level Voltage, 1: High Level Voltage

6. INTERFACE TIMING

6.1 INPUT SIGNAL TIMING SPECIFICATIONS

The input signal timing specifications are shown as the following table and timing diagram.

Signal	Item	Symbol	Min.	Typ.	Max.	Unit	Note
LVDS Clock	Frequency	Fc	58.54	74.25	97.98	MHz	-
	Period	Tc	-	13.47	-	ns	
	Input cycle to cycle jitter	T _{rd}	-0.02*Tc	-	0.02*Tc	ns	(a)
	Input Clock to data skew	TLVCCS	-0.02*Tc	-	0.02*Tc	ps	(b)
	Spread spectrum modulation range	F _{clk_{in}_mod}	0.97*Fc	---	1.03*Fc	MHz	(c)
	Spread spectrum modulation frequency	F _{SSM}	---	---	100	KHz	
Vertical Display Term	Frame Rate	Fr	50	60	75	Hz	Tv=Tvd+Tvb
	Total	Tv	1110	1125	1220	Th	-
	Active Display	Tvd	1080	1080	1080	Th	-
	Blank	Tvb	Tv-Tvd	45	Tv-Tvd	Th	-
Horizontal Display Term	Total	Th	1050	1100	1150	Tc	Th=Thd+Thb
	Active Display	Thd	960	960	960	Tc	-
	Blank	Thb	Th-Thd	140	Th-Thd	Tc	-

Note (1) Because this module is operated by DE only mode, Hsync and Vsync input signals should be set to low logic level or ground. Otherwise, this module would operate abnormally.

Note (2) The Tv(Tvd+Tvb) must be integer, otherwise, the module would operate abnormally.

INPUT SIGNAL TIMING DIAGRAM

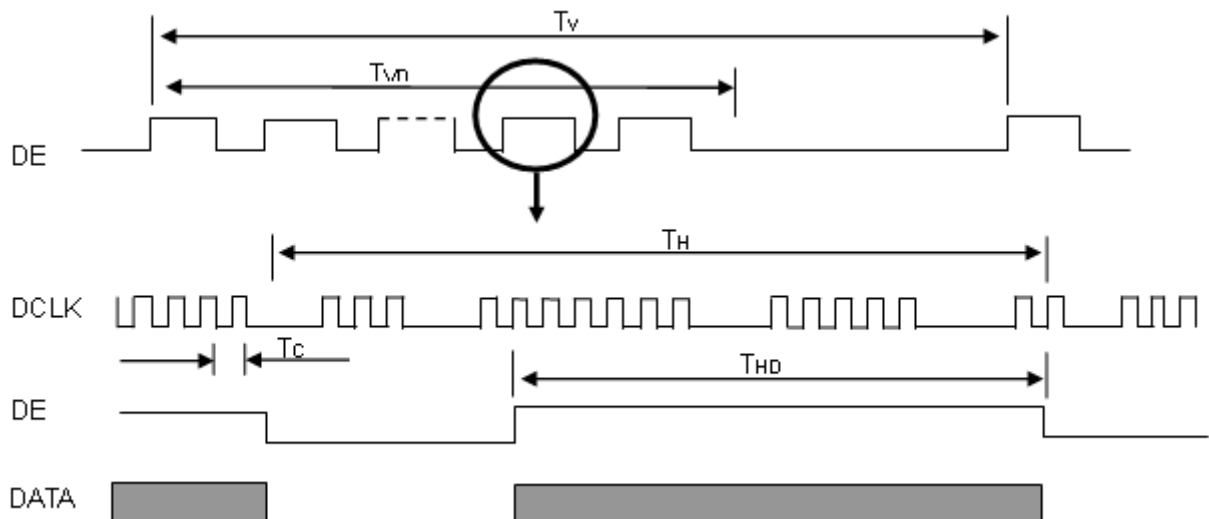

TIMING DIAGRAM of LVDS

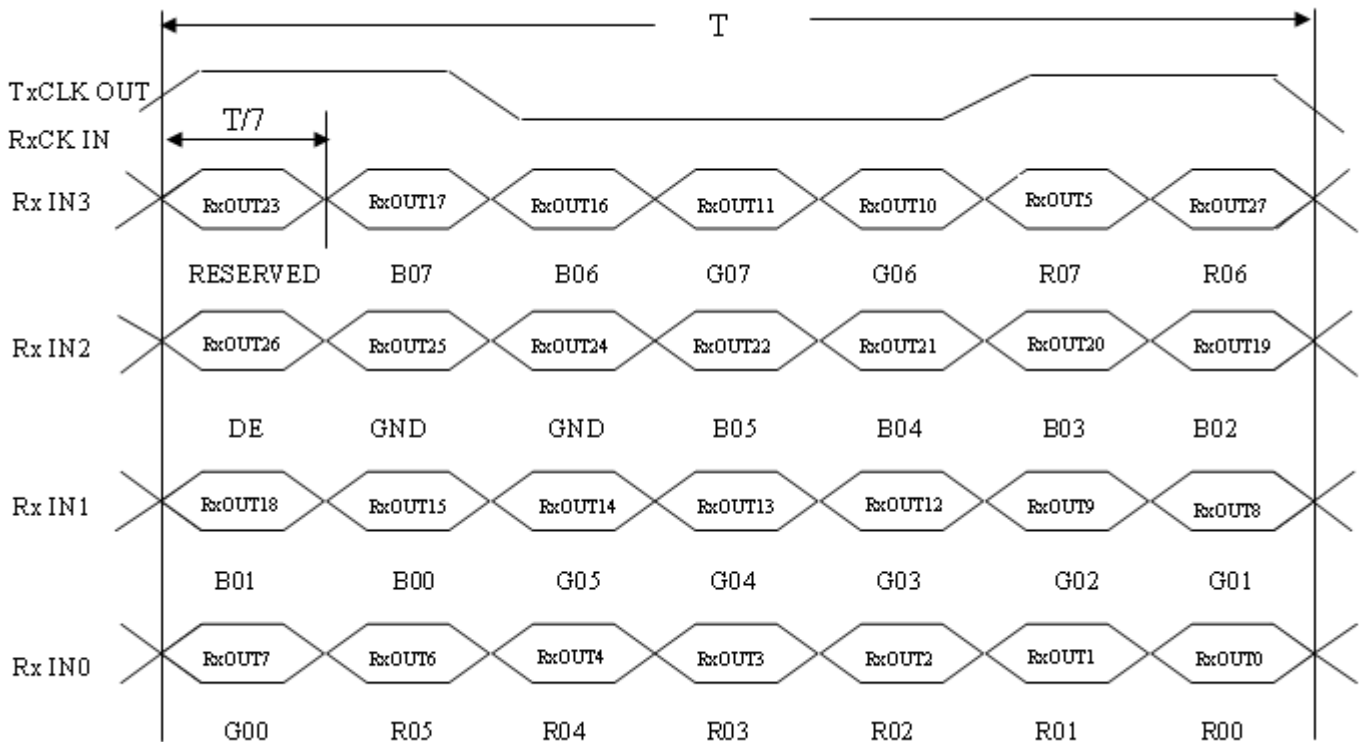

Note (a) The input clock cycle-to-cycle jitter is defined as below figures. $T_{rd} = |T1 - T1|$

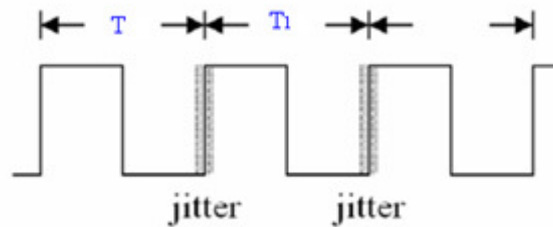

Note (b) Input Clock to data skew is defined as below figures.

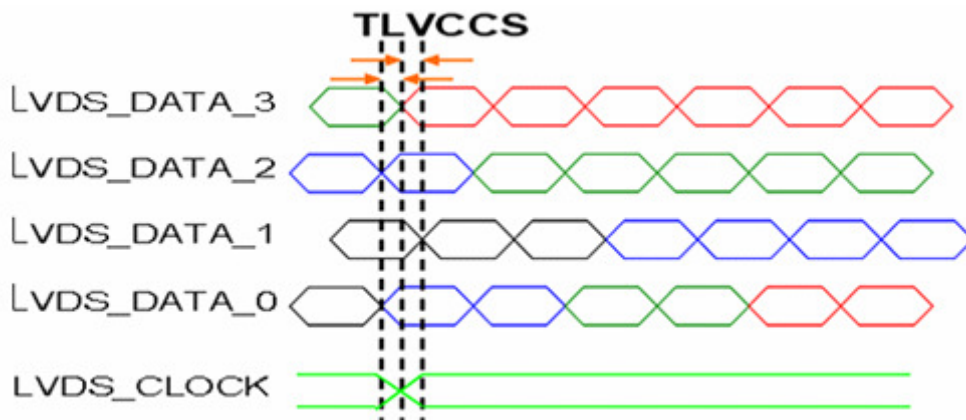

Note (c) The SSCG (Spread spectrum clock generator) is defined as below figures.

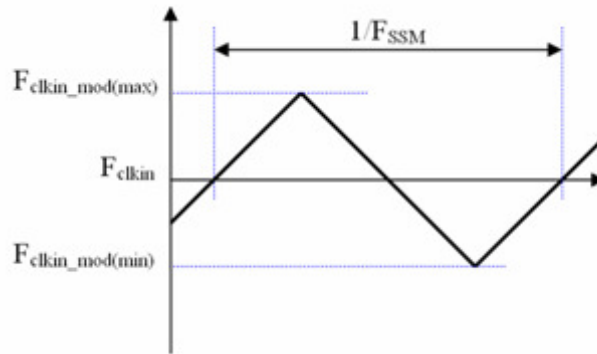

6.2 POWER ON/OFF SEQUENCE

To prevent a latch-up or DC operation of LCD assembly, the power on/off sequence should be as the diagram below.

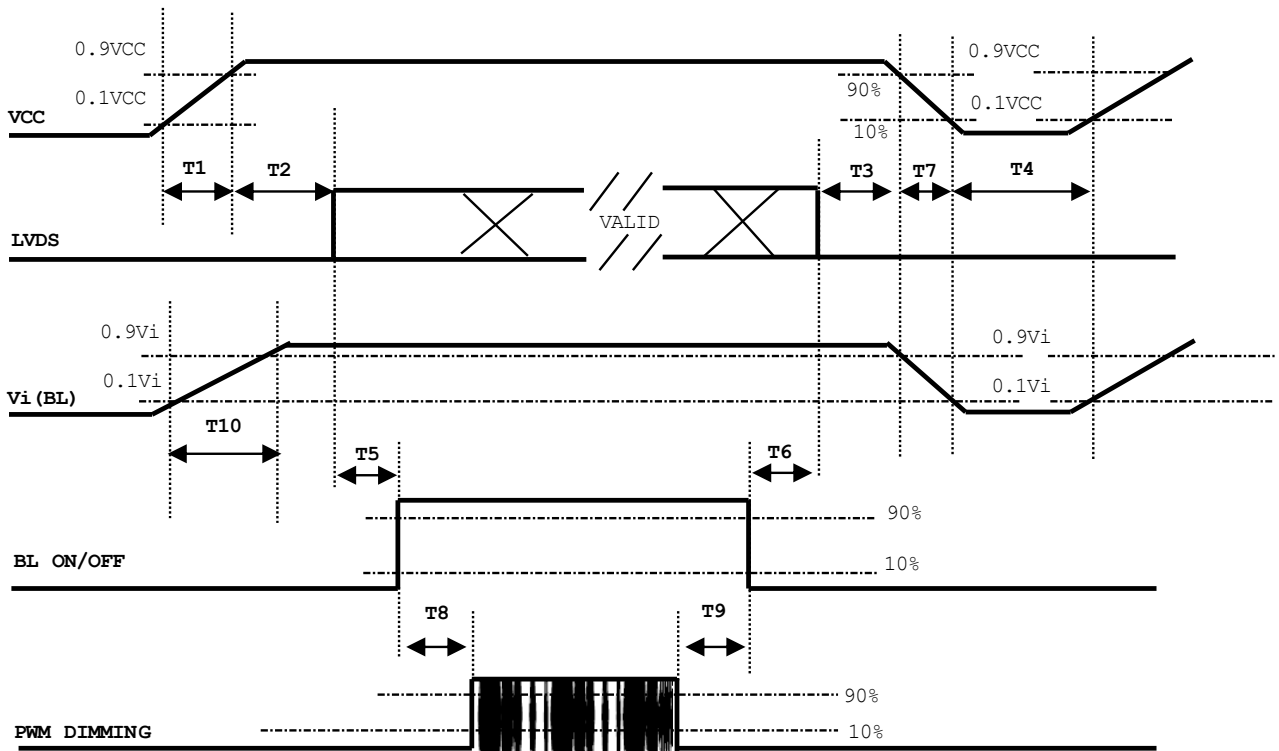

Parameter	Value			Units Min
	Min	Typ	Max	
T1	0.5	-	10	ms
T2	0	-	50	ms
T3	0	-	50	ms
T4	500	-	-	ms
T5	450	-	-	ms
T6	200	-	-	ms
T7	10	-	100	ms
T8	10	-	-	ms
T9	10	-	-	ms
T10	20	-	50	ms

Note:

- (1) The supply voltage of the external system for the module input should be the same as the definition of Vcc.
- (2) When the backlight turns on before the LCD operation of the LCD turns off, the display may momentarily become abnormal screen.
- (3) In case of VCC = off level, please keep the level of input signals on the low or keep a high impedance.
- (4) T4 should be measured after the module has been fully discharged between power off and on period.
- (5) Interface signal shall not be kept at high impedance when the power is on.
- (6) INX won't take any responsibility for the products which are damaged by the customers not following the Power Sequence.
- (7) There might be slight electronic noise when LCD is turned off (even backlight unit is also off). To avoid this symptom, we suggest "Vcc falling timing" to follow "T7 spec".

7. OPTICAL CHARACTERISTICS

7.1 TEST CONDITIONS

Item	Symbol	Value	Unit
Ambient Temperature	Ta	25±2	°C
Ambient Humidity	Ha	50±10	%RH
Supply Voltage	According to typical value and tolerance in "ELECTRICAL CHARACTERISTICS"		
Input Signal			
PWM Duty Ratio	D	100	%

7.2 OPTICAL SPECIFICATIONS

The relative measurement methods of optical characteristics are shown here and all items are measured at the center point of screen unless otherwise noted. The following items should be measured under the test conditions described above and stable conditions shown in Note (5).

Item	Symbol	Condition	Min.	Typ.	Max.	Unit	Note	
Color Chromaticity	Red	Rx	0.602	0.652	0.702	-	(1), (5)	
		Ry	0.288	0.338	0.388			
	Green	Gx	0.268	0.318	0.368			
		Gy	0.566	0.616	0.666			
	Blue	Bx	0.098	0.148	0.198			
		By	0.005	0.055	0.105			
	White	Wx	0.263	0.313	0.363			
		Wy	0.279	0.329	0.379			
Center Luminance of White	LC	θX=0°, θY =0° Grayscale Maximum	700	1000			(4), (5)	
Contrast Ratio	CR		700	1000		-	(2), (5)	
Response Time	TR	θX=0°, θY =0°	-	14	19	-	(3)	
	TF			11	16	-		
White Variation	δW	θX=0°, θY =0°	70	75	-	%	(5), (6)	
Viewing Angle	Horizontal	θX+	CR ≥ 10	85	89	-	Deg.	(1), (5)
		θX-		85	89	-		
	Vertical	θY+		85	89	-		
		θY-		85	89	-		

Definition :

Grayscale Maximum : Grayscale 255 (10 bits: grayscale 1023 ; 8 bits : grayscale 255 ; 6 bits: grayscale 63)

White : Luminance of Grayscale Maximum (All R,G,B)

Black : Luminance of grayscale 0 (All R,G,B)

Note (1) Definition of Viewing Angle (θ_x, θ_y):

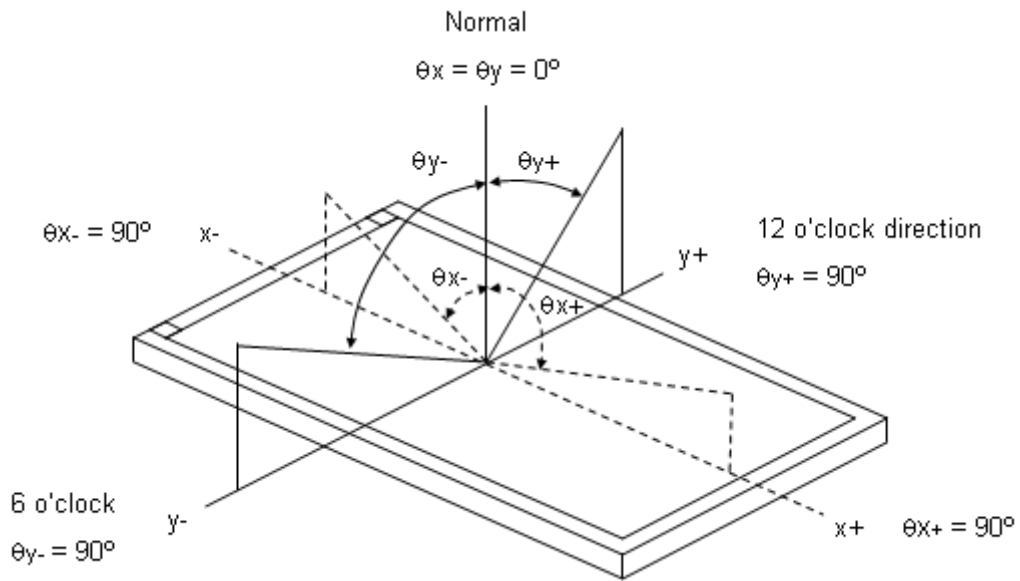

Note (2) Definition of Contrast Ratio (CR):

The contrast ratio can be calculated by the following expression at center point.

$$\text{Contrast Ratio (CR)} = \text{White} / \text{Black}$$

Note (3) Definition of Response Time (T_R, T_F):

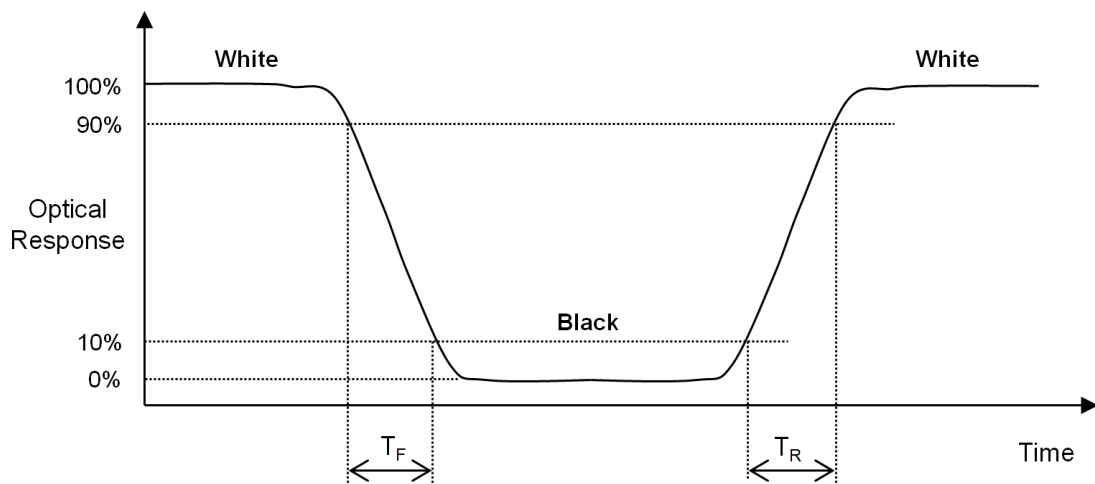

Note (4) Definition of Luminance of White (L_c):

Measure the luminance of White at center point.

Note (5) Measurement Setup:

The LCD module should be stabilized at given temperature to avoid abrupt temperature change during measuring. In order to stabilize the luminance, the measurement should be executed after lighting Backlight for 40 minutes in a windless room. The measurement placement of module should be in accordance with module drawing.

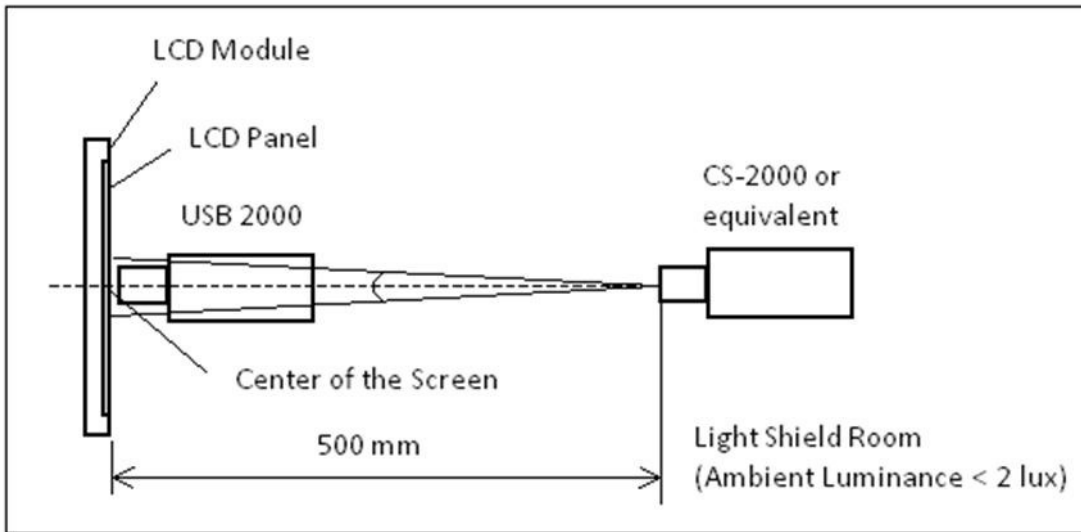

Note (6) Definition of White Variation (δW):

Measure the luminance of White at 9 points.

Luminance of White : $L(X)$, where X is from 1 to 9.

$$\delta W = \frac{\text{Minimum [} L(1) \text{ to } L(9) \text{]}}{\text{Maximum [} L(1) \text{ to } L(9) \text{]}} \times 100\%$$

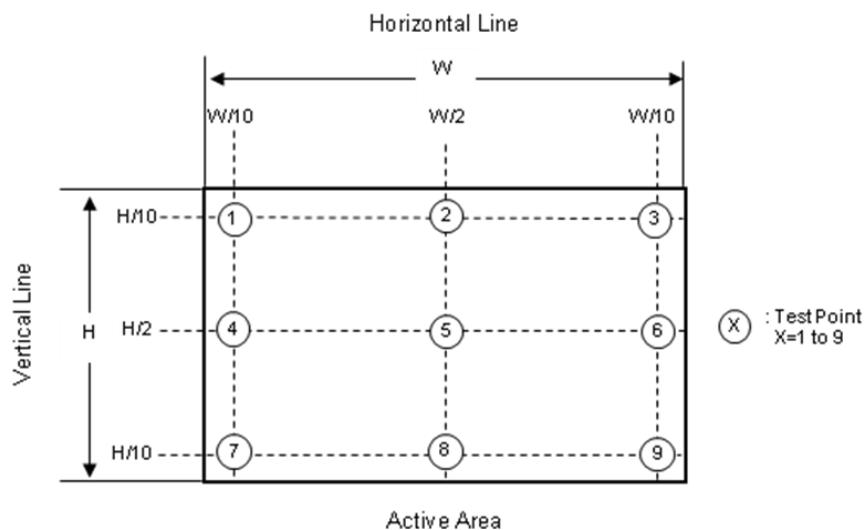

8. RELIABILITY TEST CRITERIA

Test Item	Test Condition	Note
High Temperature Storage Test	80°C, 240 hours	(1),(2) (4),(5)
Low Temperature Storage Test	-30°C, 240 hours	
Thermal Shock Storage Test	-20°C, 0.5 hour ↔ 60°C, 0.5 hour; 100cycles, 1 hour/cycle)	
High Temperature Operation Test	80°C, 240 hours	
Low Temperature Operation Test	-30°C, 240 hours	
High Temperature & High Humidity Operation Test	60°C, RH 90%, 240 hours	
ESD Test (Operation)	150pF, 330Ω, 1 sec/cycle Condition 1 : panel contact, ±8 KV Condition 2 : panel non-contact ±15 KV	(1), (4)
Shock (Non-Operating)	50G, 11ms, half sine wave, 1 time for ± X, ± Y, ± Z direction	(2), (3)
Vibration (Non-Operating)	1.5G, 10 ~ 300 Hz sine wave, 10 min/cycle, 3 cycles each X, Y, Z direction	

Note (1) There should be no condensation on the surface of panel during test ,

Note (2) Temperature of panel display surface area should be 80°C Max. And it also should be followed by the de-rating condition as 3.2 Backlight Unit note (4).

Note (3) At testing Vibration and Shock, the fixture in holding the module has to be hard and rigid enough so that the module would not be twisted or bent by the fixture.

Note (4) In the standard conditions, there is no function failure issue occurred. All the cosmetic specification is judged before reliability test.

Note (5) Before cosmetic and function test, the product must have enough recovery time, at least 24 hours at room temperature.

9. PACKAGING

9.1 PACKING SPECIFICATIONS

- (1) 10 LCD modules / 1 Box
- (2) Box dimensions: 620(L) X 348(W) X 430(H) mm
- (3) Weight: approximately: 30.4kg (10 modules per box)

9.2 PACKING METHOD

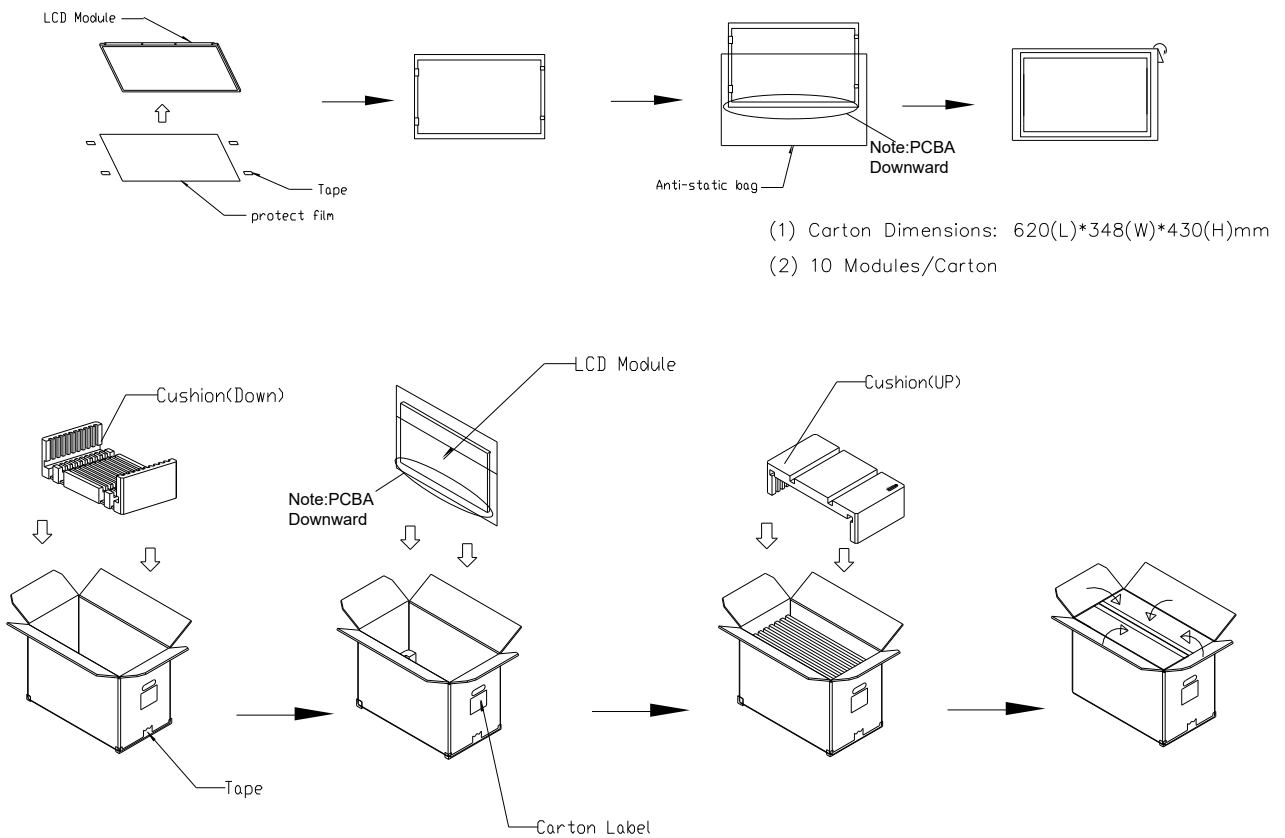
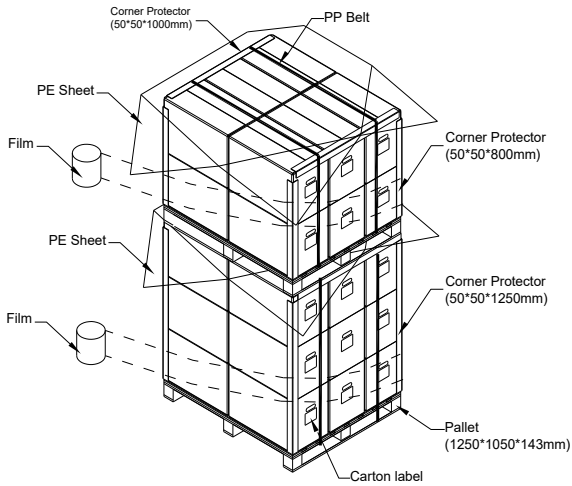

Figure. 9-1 Packing method

For ocean

Sea / Land Transportation (40ft HQ Container)



Sea / Land Transportation (40ft/20ft Container)

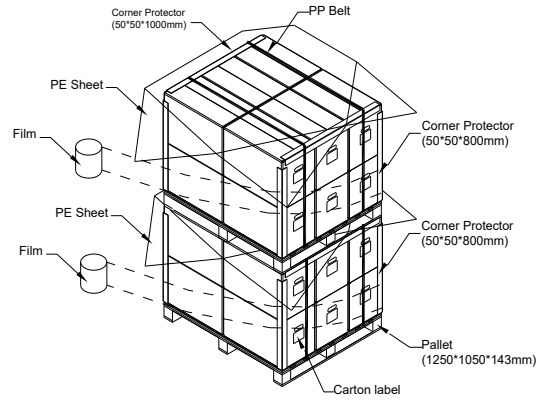

For air

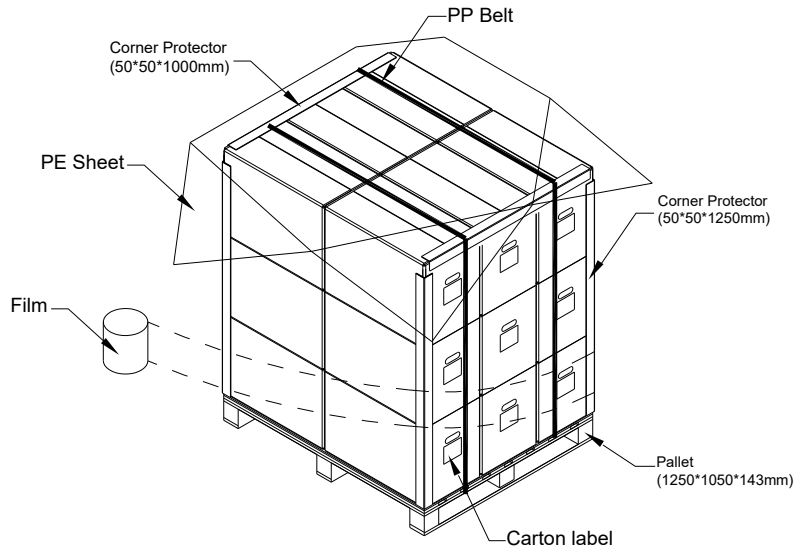

Figure. 9-2 Packing method

9.3 UN-PACKING METHOD

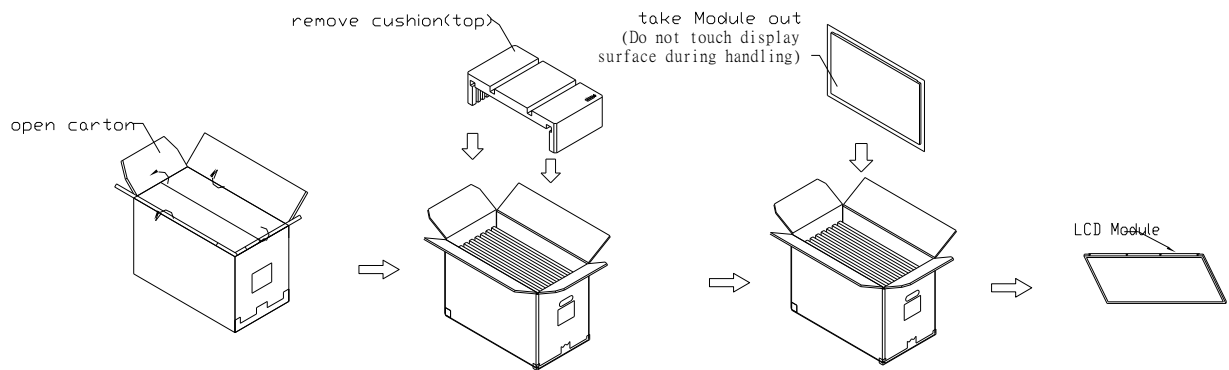
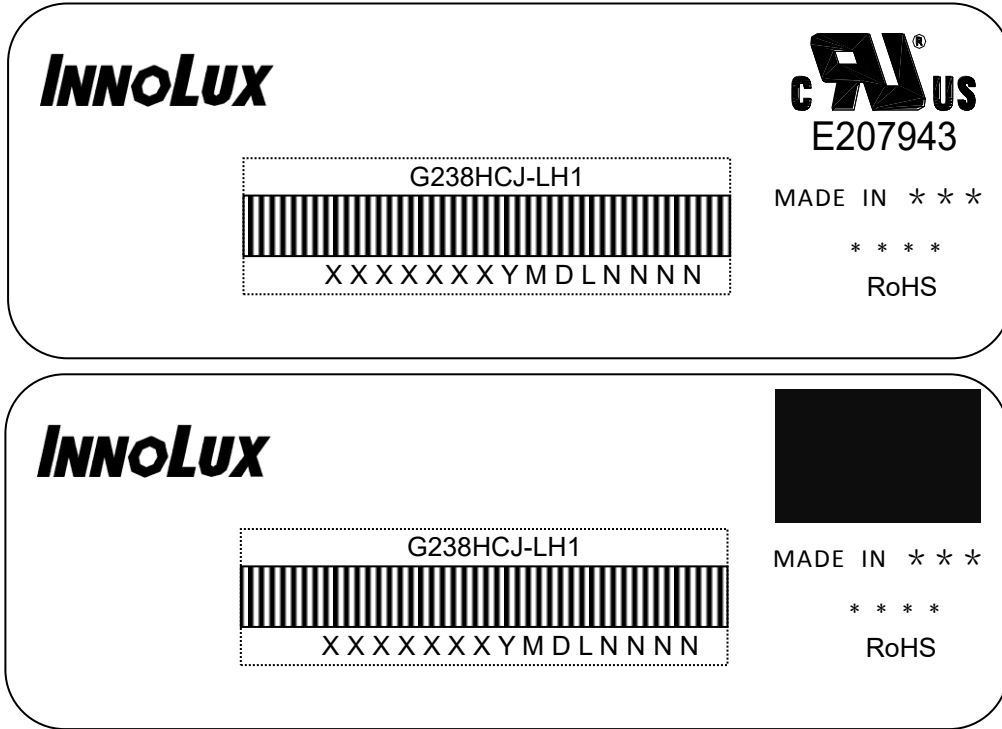

Figure. 9-3 UN-Packing method

10. DEFINITION OF LABELS

10.1 INX MODULE LABEL

The barcode nameplate is pasted on each module as illustration, and its definitions are as following explanation.



Note (1) Safety Compliance(UL logo) will open after C1 version.

- (a) Model Name: G238HCJ-LH1
- (b) * * * * : Factory ID
- (c) Serial ID: XXXXXXXXYMDXNNNN

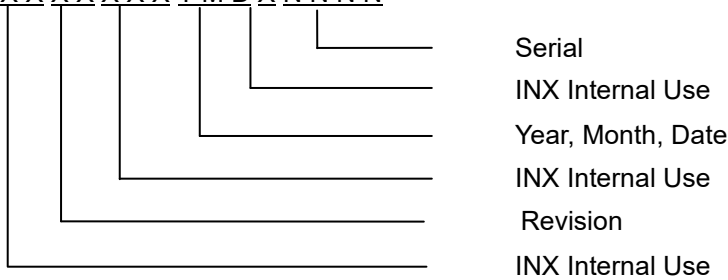

Serial ID includes the information as below:

- (a) Manufactured Date: Year: 1~9, for 2021~2029
 Month: 1~9, A~C, for Jan. ~ Dec.
 Day: 1~9, A~Y, for 1st to 31st, exclude I , O and U
- (b) Revision Code: cover all the change
- (c) Serial No.: Manufacturing sequence of product

11. PRECAUTIONS**11.1 ASSEMBLY AND HANDLING PRECAUTIONS**

- (1) The module should be assembled into the system firmly by using every mounting hole. Be careful not to twist or bend the module.
- (2) While assembling or installing modules, it can only be in the clean area. The dust and oil may cause electrical short or damage the polarizer.
- (3) Use fingerstalls or soft gloves in order to keep display clean during the incoming inspection and assembly process.
- (4) Do not press or scratch the surface harder than a HB pencil lead on the panel because the polarizer is very soft and easily scratched.
- (5) If the surface of the polarizer is dirty, please clean it by some absorbent cotton or soft cloth. Do not use Ketone type materials (ex. Acetone), Ethyl alcohol, Toluene, Ethyl acid or Methyl chloride. It might permanently damage the polarizer due to chemical reaction.
- (6) Wipe off water droplets or oil immediately. Staining and discoloration may occur if they left on panel for a long time.
- (7) If the liquid crystal material leaks from the panel, it should be kept away from the eyes or mouth. In case of contacting with hands, legs or clothes, it must be washed away thoroughly with soap.
- (8) Protect the module from static electricity, it may cause damage to the C-MOS Gate Array IC.
- (9) Do not disassemble the module.
- (10) Do not pull or fold the lamp wire.
- (11) Pins of I/F connector should not be touched directly with bare hands.

11.2 STORAGE PRECAUTIONS

- (1) When storing for a long time, the following precautions are necessary.
 - (a) Store them in a dark place. Do not expose the module to sunlight or fluorescent light. Keep the temperature between 5°C and 30°C at humidity 50+-10%RH.
 - (b) The polarizer surface should not come in contact with any other object.
 - (c) It is recommended that they be stored in the container in which they were shipped.
 - (d) Storage condition is guaranteed under packing conditions.
 - (e) The phase transition of Liquid Crystal in the condition of the low or high storage temperature will be recovered when the LCD module returns to the normal condition
- (2) High temperature or humidity may reduce the performance of module. Please store LCD module within the specified storage conditions.
- (3) It is dangerous that moisture come into or contacted the LCD module, because the moisture may damage LCD module when it is operating.
- (4) It may reduce the display quality if the ambient temperature is lower than 10 °C. For example, the response time will become slowly, and the starting voltage of lamp will be higher than the room temperature.

11.3 OTHER PRECAUTIONS



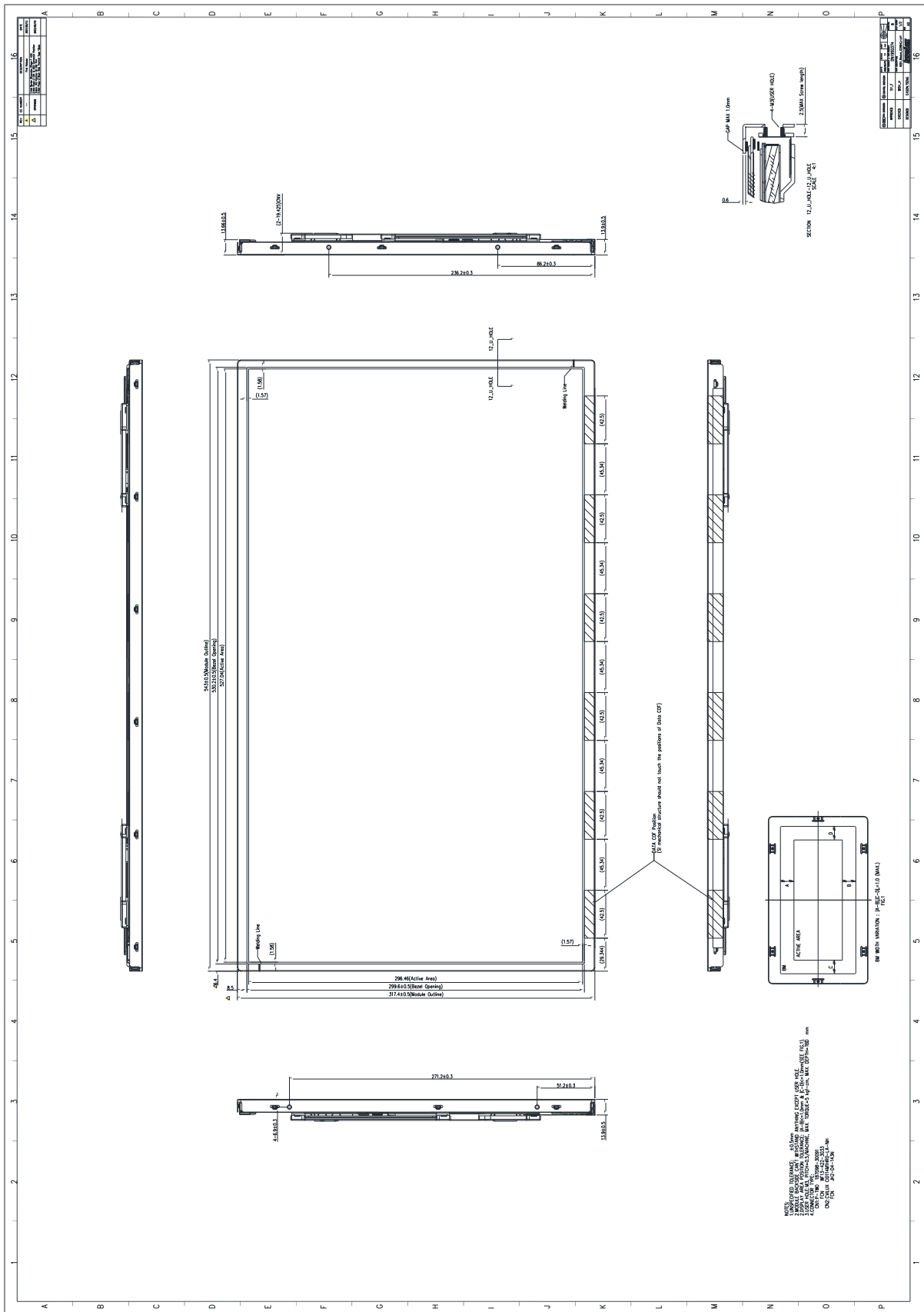

- (1) Normal operating condition
 - (a) Display pattern: dynamic pattern (Real display)
 - (Note) Long-term static display can cause image sticking.
- (2) Operating usages to protect against image sticking due to long-term static display
 - (a) Static information display recommended to use with moving image.
- (3) Abnormal condition just means conditions except normal condition.

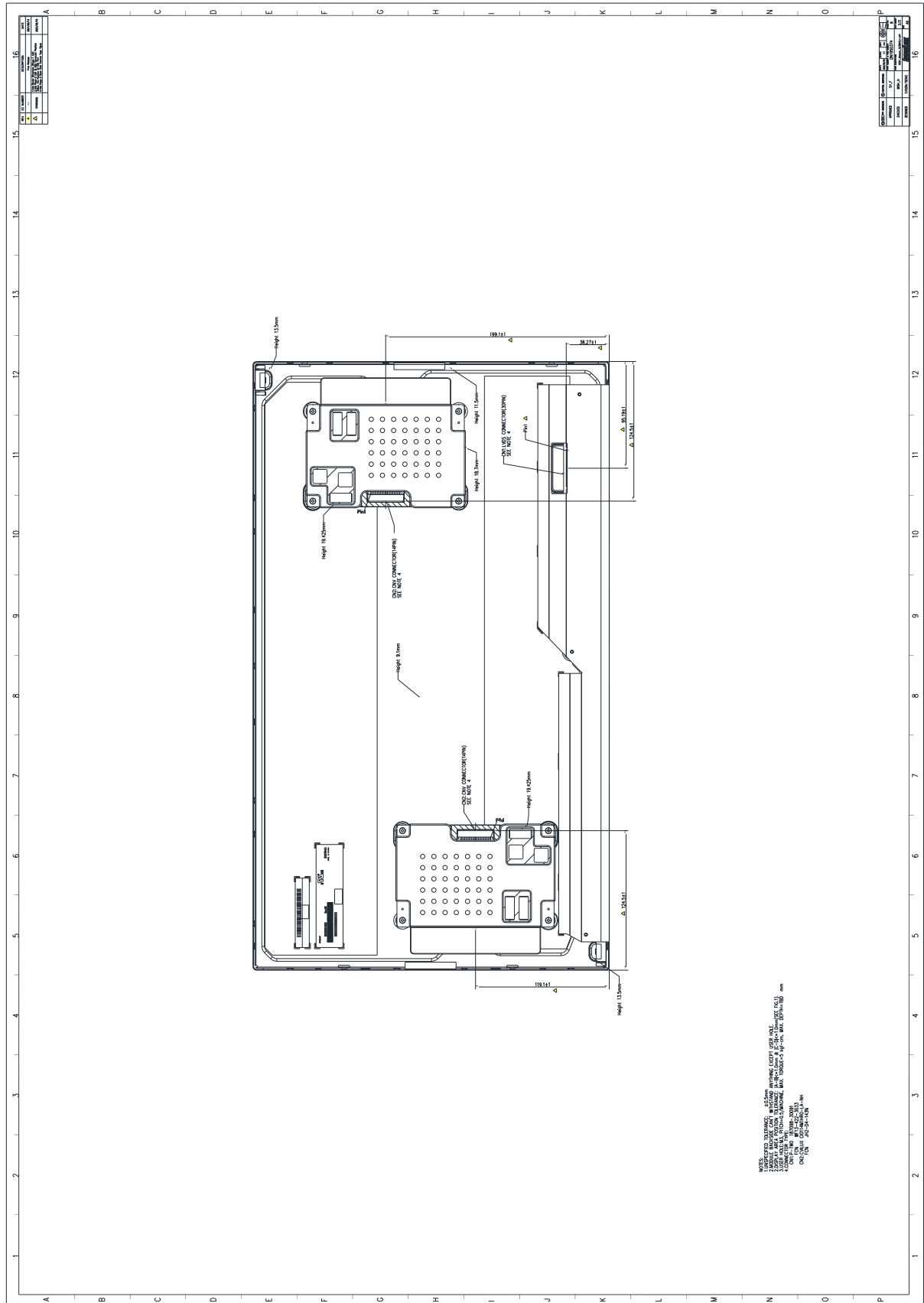
12. MECHANICAL CHARACTERISTICS



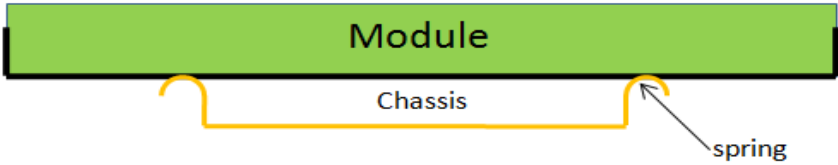

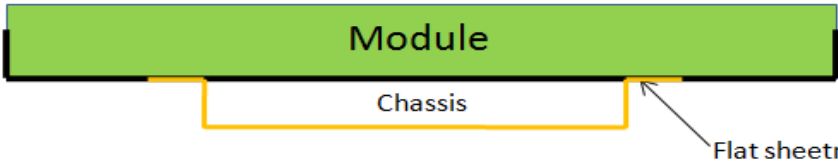
Appendix. SYSTEM COVER DESIGN NOTICE

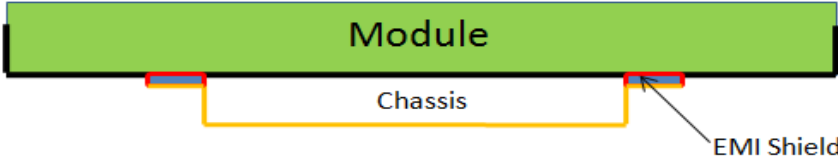
1	Set Chassis and IAVM Module touching Mode
	 <p>Module</p> <p>Chassis</p> <p>spring</p>
	 <p>Module</p> <p>Chassis</p> <p>Flat sheetmetal</p>
	 <p>Module</p> <p>Chassis</p> <p>EMI Shielding Gasket (Tape/Sponge)</p>
<p>Definition</p>	<p>a. To prevent from abnormal display & white spot after mechanical test, it is not recommended to use spring type chassis.</p> <p>b. We suggest the contact mode between Chassis and Module rear cover is Tape/Sponge, second is Flat sheet metal type chassis.</p>

2	Tape/Sponge design on system inner surface
<p>The diagram illustrates the correct and incorrect placement of Tape/Sponge on the system's inner surface. The top part is a cross-sectional view showing a green Module mounted on a yellow Chassis, with red Tape/Sponge applied between them. This assembly is housed within a cyan System rear bezel. Below this are two top-down views of the Module. The first view, marked with a red 'X', shows four red L-shaped pieces of Tape/Sponge placed at the corners of the Module. The second view, marked with a blue circle, shows a single red square piece of Tape/Sponge placed centrally over the entire back surface of the Module.</p>	
Definition	<p>a. To prevent from abnormal display & white spot after mechanical test, we suggest using Tape/Sponge as medium between chassis and Module rear cover could reduce the occurrence of white spot.</p> <p>b. When using the Tape/Sponge, we suggest it be lay over between set chassis and Module rear cover. It is not recommended to add Tape/Sponge in separate location. Since each Tape/Sponge may act as pressure concentration location.</p>

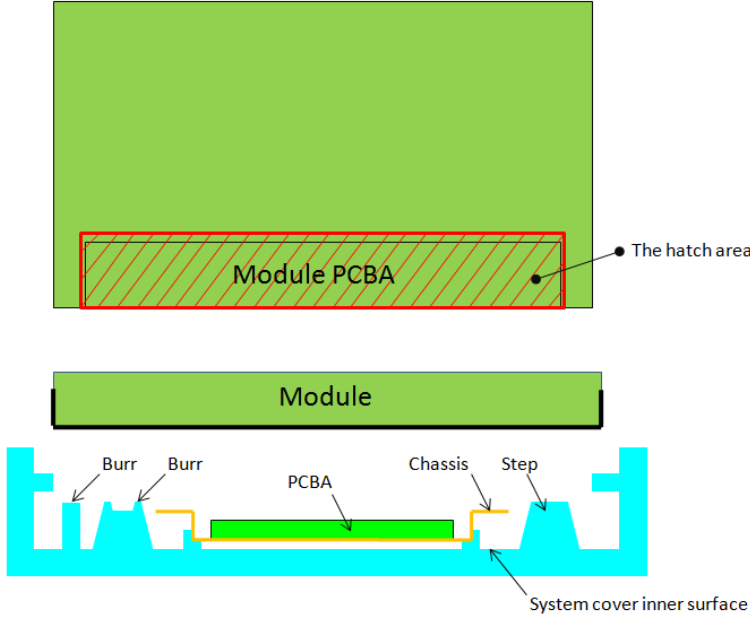
3	System inner surface examination
	
Definition	<p>a. The hatch area on Module PCBA should keep at least 1mm gap(X,Y,Z direction) to any structure with system cover inner surface.</p> <p>b. Burr, Step, PCB protrusion may cause stress concentration. White spot may occur during reliability test.</p>

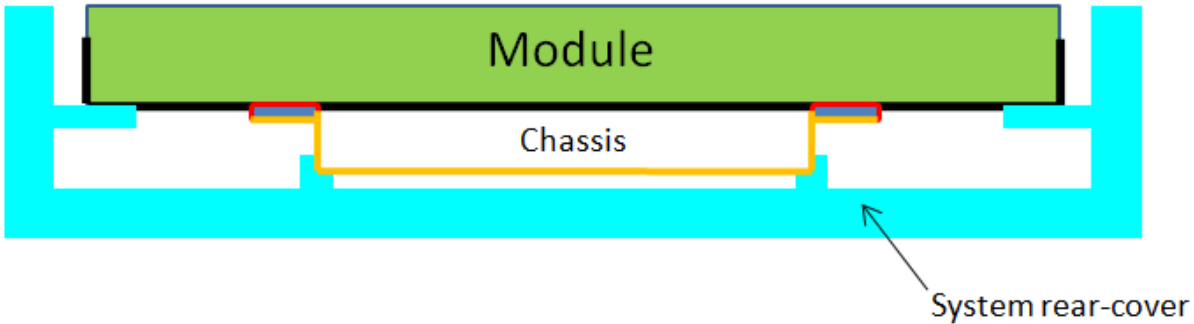
4	Material used for system rear-cover
	
Definition	<p>System rear-cover material with high rigidity is needed to resist deformation during scuffing test, hinge test, pogo test or backpack test. Abnormal display, white spot, pooling issue may occur if low rigidity material is used. Pooling issue may occur because screw's boss position for module's bracket are deformed open-close test. Solid structure design of system rear-cover may also influence the rigidity of system rear-cover. The deformation of system rear-cover should not caused interference.</p>

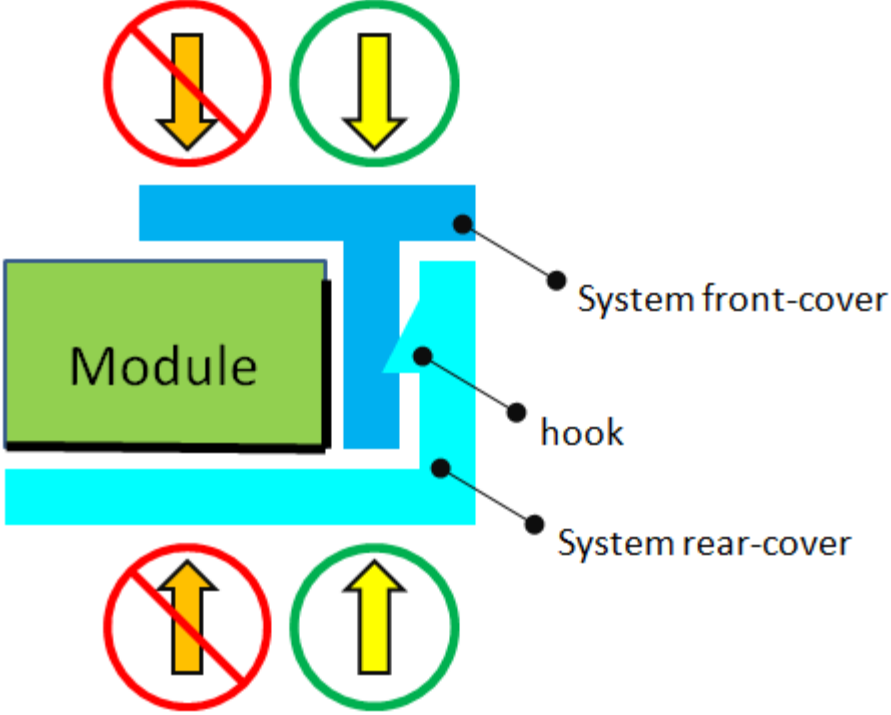
5	Assembly SOP examination for system front-cover with hook structure
	
Definition	To prevent panel crack during system front-cover assembly process with hook structure, it is not recommended to press panel or any location that relate directly to the panel.

6	Permanent deformation of system cover after reliability test
	<p>System front-cover</p> <p>System rear-cover</p> <p>Module</p> <p>deformation</p> <p>System front-cover</p> <p>System rear-cover</p> <p>Module</p> <p>deformation</p> <p>System front-cover</p> <p>System rear-cover</p> <p>Module</p> <p>System front-cover</p> <p>System rear-cover</p> <p>deformation</p> <p>System front-cover</p> <p>System rear-cover</p> <p>Module</p> <p>System front-cover</p> <p>System rear-cover</p> <p>0 gap</p> <p>System front-cover</p> <p>System rear-cover</p> <p>Module</p> <p>System front-cover</p> <p>System rear-cover</p> <p>deformation</p>
Definition	<p>System cover including front cover and rear cover may deform during reliability test. Permanent deformation of system front cover and rear cover after reliability test should not interfere with panel. Because it may cause issue such as pooling, abnormal display, white spot and also cell crack.</p> <p>Note: If the interference cannot be avoided, please feel free to contract INX FAE Engineer for collaboration design. We can help to verify and pass risk assessment for customer reference.</p>

7	Design gap A between panel & any components on system rear-cover
Definition	<p>System cover including front cover and rear cover may deform during reliability test. Permanent deformation of system front cover and rear cover after reliability test should not interfere with panel. Because it may cause issue such as pooling, abnormal display, white spot and also cell crack.</p> <p>Note: If the interference cannot be avoided, please feel free to contract INX FAE Engineer for collaboration design. We can help to verify and pass risk assessment for customer reference.</p>

8	Design gap B between system front-cover & panel surface
Definition	<p>Gap between system front-cover & panel surface is needed to prevent pooling or glass broken. Zero gap or interference such as burr and warpage from mold frame may cause pooling issue near system front-cover opening edge. This phenomenon is obvious during swing test, hinge test, knock test or during pooling inspection procedure. To remain sufficient gap, design with system rib higher than maximum panel thickness is recommended.</p> <p>Note: If the interference cannot be avoided, please feel free to contract INX FAE Engineer for collaboration design. We can help to verify and pass risk assessment for customer reference.</p>

9	Design gap C between panel & system front-cover or protrusions
<p>The diagrams illustrate the required design gap 'C' between a module and system covers. In the top diagram, the system rear-cover has a protrusion on the right side, and the gap 'C' is between the module and this protrusion. In the bottom diagram, the system rear-cover is flat, and the gap 'C' is between the module and the system front-cover. Labels include 'Module', 'System front-cover', 'System rear-cover', and 'C'.</p>	
Definition	<p>Gap between panel & system front-cover or protrusions is needed to prevent shock test failure. Because system front-cover or protrusions with small gap may hit panel during the test. Issue such as cell crack, abnormal display may occur.</p> <p>The gap should be large enough to absorb the maximum displacement during the test.</p> <p>Note: If the interference cannot be avoided, please feel free to contract INX FAE Engineer for collaboration design. We can help to verify and pass risk assessment for customer reference.</p>

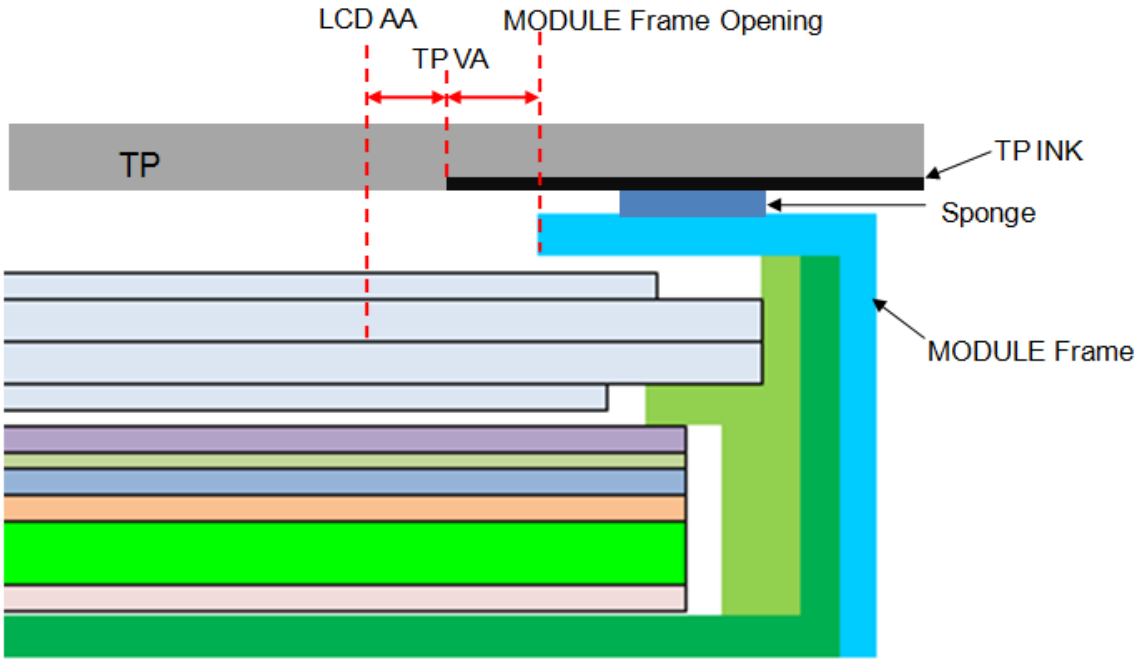
10	Design distance between TP AA to LCD AA
	
Definition	TP VA should avoid TP ink area covering LCD AA or causing the module frame to be exposed.

11	Use OCR Lamination
<p>The diagrams illustrate two methods for OCR lamination. The top diagram, marked with a red 'X', shows 'Line pooling' occurring at the edges of the 'Display Area' between the 'TP or Cover Glass' and the underlying layers. The bottom diagram, marked with a green circle, shows the correct method where 'OCR overflow' and 'Add Side glue' are applied at the edges to prevent pooling. An inset diagram provides a detailed view of the edge, showing the 'TP' (Thin Plate) and 'OCR' (Optical Clearing Resin) layers, and the 'OCR overflow' and 'Add Side glue' at the junction.</p>	
Definition	<p>1.OCR glue as possible beyond module, in order to avoid Line Pooling 2.Add side glue to avoid Line Pooling</p>



ALL TECHNOLOGIES. ALL COMPETENCIES. ONE SPECIALIST.



DATA MODUL AG
Landsberger Straße 322 DE-
80687 Munich
Phone: +49-89-56017-0

DATA MODUL WEIKERSHEIM GMBH
Lindenstraße 8
DE-97990 Weikersheim Phone:
+49-7934-101-0



More information and worldwide locations can be found at

www.data-modul.com