



SPECIFICATION



HSD042GPW1-90000D-MX

4.2" - Reflective mono TFT incl. Frontlight

Version: 1.0

Date: 20.12.2022

Note: This specification is subject to change without prior notice



Document Title	HSD042GPW1-90000D-MX Preliminary Specification	Page No.	1/21
Document No.	DC	Revision	1.0

TO : Data Modul

Date : 2022.12.20

HannStar Product Specification **(Preliminary)**

4.2” Reflective Mono TFT-LCD Module **Model : HSD042GPW1-90000D-MX**

Note:

- (1) The information contained herein is preliminary and may be changed without prior notices
- (2) Please contact HannStar Display Corp. before designing your product based on this module specification.
- (3) The information contained herein is presented merely to indicate the characteristics and performance of our products. No responsibility is assumed by HannStar for any intellectual property claims or other problems that may result from application based on the module described herein.
- (4) The mark “ ** ” of Model means sub-model code.



Document Title	HSD042GPW1-90000D-MX Preliminary Specification	Page No.	2/21
Document No.	DC	Revision	1.0

Record of Revisions

Rev.	Date	Sub-Model	Description of change
1.0	Dec., 14, 2022	90000D-MX	Preliminary Product Specification was first released.



Document Title	HSD042GPW1-90000D-MX Preliminary Specification	Page No.	3/21
Document No.	DC	Revision	1.0

Contents

1.0	GENERAL DESCRIPTION	錯誤! 尚未定義書籤。
2.0	ABSOLUTE MAXIMUM RATINGS	5
3.0	OPTICAL CHARACTERISTICS	6
4.0	BLOCK DIAGRAM.....	9
5.0	INTERFACE PIN CONNECTION	111
6.0	ELECTRICAL CHARACTERISTICS.....	13
7.0	RELIABILITY TEST ITEMS	16
8.0	OUTLINE DIMENSION.....	17
9.0	LOT MARK	18
10.0	PACKAGE SPECIFICATION	19
11.0	GENERAL PRECAUTION	20

Document Title	HSD042GPW1-90000D-MX Preliminary Specification	Page No.	4/21
Document No.	DC	Revision	1.0

1.0 GENERAL DESCRIPTION

1.1 Introduction

HannStar Display model HSD042GPW1-90000D-MX is a mono active matrix thin film transistor (TFT) liquid crystal display (LCD) that uses amorphous silicon TFT as a switching device. It is a reflective type display operating in the total reflection. This model is composed of a TFT LCD panel, driving circuit and a front- light system. This TFT LCD has a 4.2 inch diagonally measured active display area with 300 horizontal by 400 vertical pixel resolution.

1.2 Features

- 4.2 inch configuration
- Mono by 1 bit signal input
- RoHS Compliance & Halogen Free

1.3 Applications

- Industrial Control Application

1.4 General Information

Item	Specification	Unit
Outline Dimension	67.6(H)x95.1(V)x1.502(T) (Typ.)	mm
Display Area	63.6(H)x84.8(V)	mm
Number of Pixel	300(H)x400(V)	pixels
Pixel Pitch	0.212(H)x0.212(V)	mm
Pixel arrangement	Mono	
Display Mode	Normally White	
Interface	SPI	
Frame rate	1	Hz
Surface treatment	HC	Note
Weight	TBD (Typ.)	g
Power Consumption	FOG system	mW
	F/L system	

Note: Due to the special surface treatment of the light guide plate, HannStar recommend to attach by air bonding above it instead of direct bonding.

Document Title	HSD042GPW1-90000D-MX Preliminary Specification	Page No.	5/21
Document No.	DC	Revision	1.0

1.5 Mechanical Information

Item		Min.	Typ.	Max.	Unit
Module Size	Horizontal (H)		67.6		mm
	Vertical (V)		95.1		mm
	Depth (D)		1.502		mm
Weight		—	TBD	TBD	g

2.0 ABSOLUTE MAXIMUM RATINGS

2.1 Electrical Absolute Rating

Item	Symbol	Min.	Max.	Unit	Note
Supply Voltage	VDDI	-0.3	3.6	V	GND=0
Logic Input Voltage	VIN	-0.3	3.6	V	GND=0

Note :

- (1) Permanent damage may occur to the LCD module if beyond this specification. Functional operation should be restricted to the conditions described under normal operating conditions.
- (2) Ta =25±2°C

2.2 Environment Absolute Rating

Item	Symbol	Min.	Max.	Unit	Note
Operating Temperature	T _{opa}	-20	70	°C	
Storage Temperature	T _{stg}	-30	80	°C	

Document Title	HSD042GPW1-90000D-MX Preliminary Specification	Page No.	6/21
Document No.	DC	Revision	1.0

3.0 OPTICAL CHARACTERISTICS

3.1 Optical Specification (Front Light off)

Item	Symbol	Condition	Min.	Typ.	Max.	Unit	Note
White Reflectance (with Polarizer)	Rw (%)	$\Theta=0$ Normal viewing angle —	—	43.14	—	%	
Contrast Ratio	CR		—	15	—	—	
White chromaticity (CIE1931)	Wx		—	0.300			
	Wy		—	0.330			
Response Time	Ms			5			
Viewing Angle	Hor.	Θ_L	—	60	—	—	
		Θ_R	—	60	—		
	Ver.	Θ_U	—	60	—		
		Θ_D	—	60	—		

3.2 Optical Specification (Front Light on)

Item	Symbol	Condition	Min.	Typ.	Max.	Unit	Note
Contrast Ratio	CR	$\Theta=0$ Normal viewing angle	—	(9.7)	—	%	
White luminance	Y_L		—	(500)			
White chromaticity (CIE1931)	Wx		—	0.2807			
	Wy		—	0.2851			
Response Time	Ms			5			
Viewing Angle	Hor.	Θ_L	—	60	—	—	
		Θ_R	—	60	—		
	Ver.	Θ_U	—	30	—		
		Θ_D	—	30	—		

Document Title	HSD042GPW1-90000D-MX Preliminary Specification	Page No.	7/21
Document No.	DC	Revision	1.0

3.3 Measuring Condition

- Measuring surrounding : dark room
- Ambient temperature : 25±2°C
- 15min. warm-up time.

3.2 Measuring Equipment

- DMS (DMS = Display Measurement System) of AUTRONIC-MELCHERS GmbH, motorized goniometer system for comprehensive display characterization

Note (1) Definition of Viewing Angle:

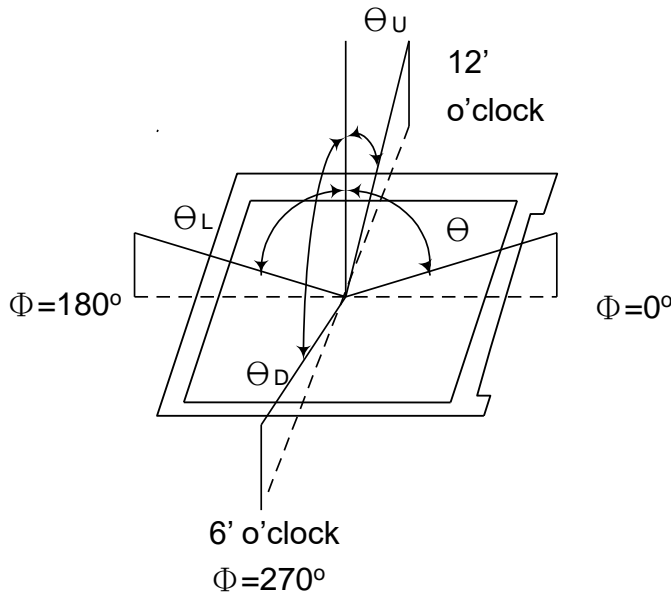

Note (2) Definition of Contrast Ratio (CR) :
measured at the center point of panel

$$CR = \frac{\text{Luminance with all pixels white}}{\text{Luminance with all pixels black}}$$

Document Title	HSD042GPW1-90000D-MX Preliminary Specification	Page No.	8/21
Document No.	DC	Revision	1.0

Note (3) Definition of Response Time : Sum of T_R and T_F

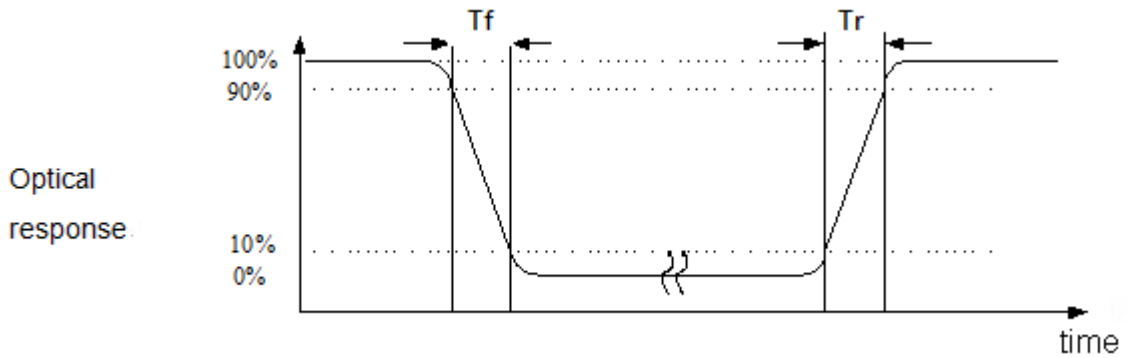

Note (4) Definition of optical measurement setup

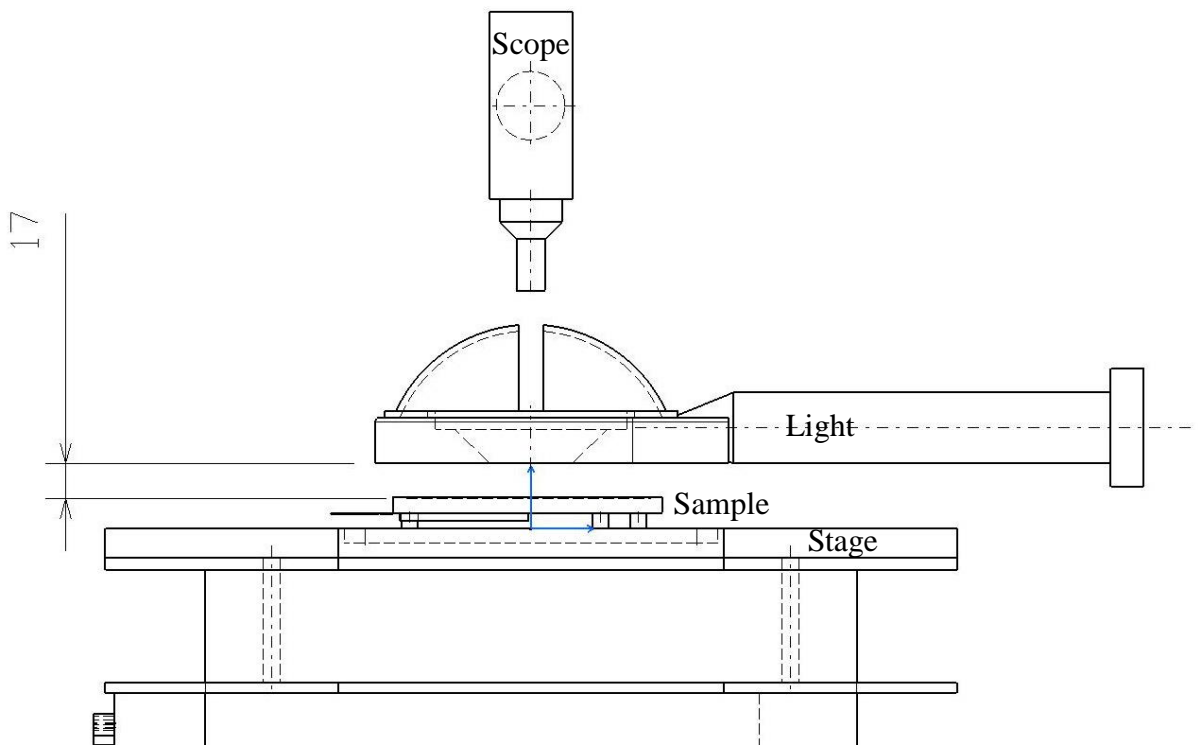

Document Title	HSD042GPW1-90000D-MX Preliminary Specification	Page No.	9/21
Document No.	DC	Revision	1.0

4.0 BLOCK DIAGRAM

4.1 TFT LCD Module:

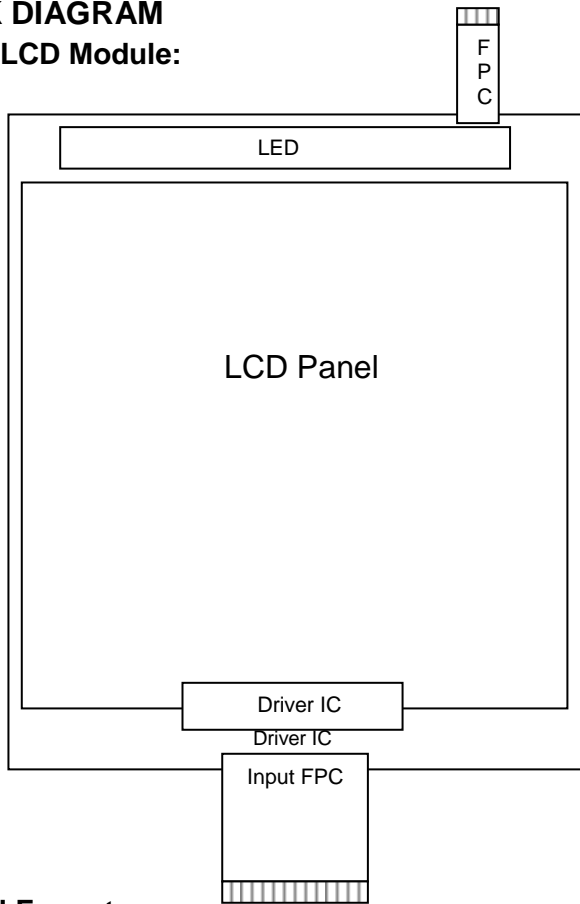

4.2 Pixel Format

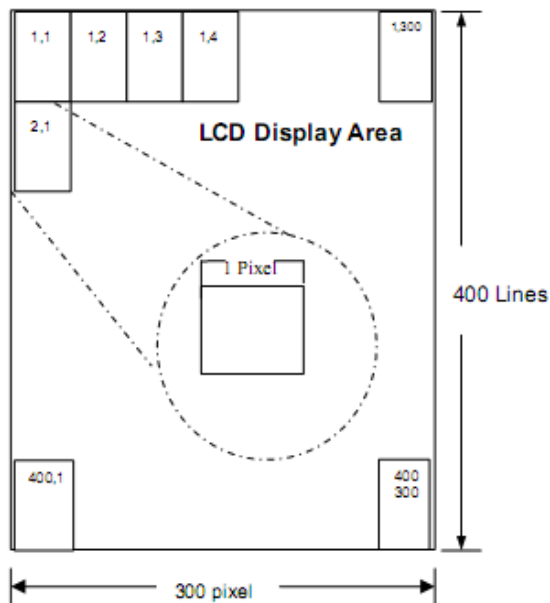



Document Title	HSD042GPW1-90000D-MX Preliminary Specification	Page No.	10/21
Document No.	DC	Revision	1.0

4.3 Relationship Between Displayed Color and Input

	Display	Bit	Gray scale Level
White & Black	Black	H	--
	White	L	--

Note: ST7306+HSD042GPW1 have no Gray scale, only Black and White on display.

Document Title	HSD042GPW1-90000D-MX Preliminary Specification	Page No.	11/21
Document No.	DC	Revision	1.0

5.0 INTERFACE PIN CONNECTION

5.1 SPI Interface

PIN	SYMBOL	Description
1	GND	Ground
2	GND	Ground
3	VDDA	3.2V(min.)/3.3V(Typ.)/3.4V(Max.)
4	VDDI	3.2V(min.)/3.3V(Typ.)/3.4V(Max.)
5	NC	Not connect
6	NC	Not connect
7	DB0	Not connect
8	DB1	Not connect
9	DB2	Not connect
10	DB3	Not connect
11	DB4	Not connect
12	DB5	Not connect
13	NC	Not connect
14	NC	Not connect
15	DB6	Not connect
16	DB7	Not connect
17	DB8	Not connect
18	DB9	Not connect
19	DB10	Not connect
20	DB11	Not connect
21	NC	Not connect
22	NC	Not connect
23	DB12	Not connect
24	DB13	Not connect
25	DB14	Not connect
26	DB15	Not connect
27	DB16	Not connect
28	DB17	Not connect
29	GND	Ground
30	DCLK	Not connect
31	RESET	Reset
32	HSYNC	Not connect
33	VSYNC	Not connect
34	DE	Not connect
35	IM3	Not connect

Document Title	HSD042GPW1-90000D-MX Preliminary Specification	Page No.	12/21
Document No.	DC	Revision	1.0

PIN	SYMBOL	Description
36	IM2	Not connect
37	IM1	Not connect
38	IM0/ID	Not connect
39	LED_ON	HSD Reserved Function(OTP Power Use)
40	LED_PWM	Not connect
41	A0	SPI Data/command Select(4wire SPI interface)
42	RD	Not connect
43	SCL/WR	SPI Clock Input(4wire SPI interface)
44	SDI/SDA	SPI Data Input(4wire SPI interface)
45	CS	SPI Chip Select(4wire SPI interface)
46	LED-	LED-
47	LED+	LED+
48	GND	Ground
49	GND	Ground
50	GND	Ground

5.2 Light bar Pin Assignment

No.	Symbol	Description
1	LED+	LED Anode
2	LED+	LED Anode
3	NC	not connect
4	NC	not connect
5	LED1-	LED CH1 cathode
6	LED2-	LED CH2 cathode
7	LED3-	LED CH3 cathode
8	LED4-	LED CH4 cathode
9	LED5-	LED CH5 cathode
10	LED6-	LED CH6 cathode

Document Title	HSD042GPW1-90000D-MX Preliminary Specification	Page No.	13/21
Document No.	DC	Revision	1.0

6.0 ELECTRICAL CHARACTERISTICS

6.1 TFT LCD Module

Item	Symbol	Min.	Typ.	Max.	Unit	Note
Supply Voltage (I/O)	VDD	3.2	3.3	3.4	V	VDDA/VDDI
Operating current	IDD	-	45	50	uA	VDD=3.3V
Input signal voltage	ViH	0.8*VDDI	-	VDDI	V	
	ViL	0	-	0.2*VDDI	V	

6.2 Timing Characteristic

6.2.1 Single 4-Line Serial Interface

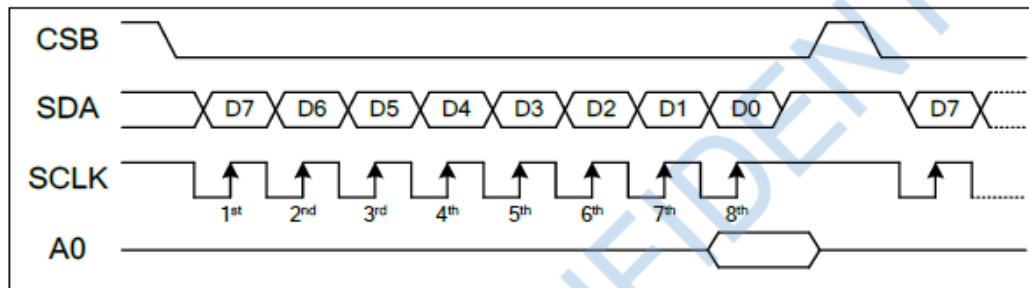

Write Operation of 4-Line SPI

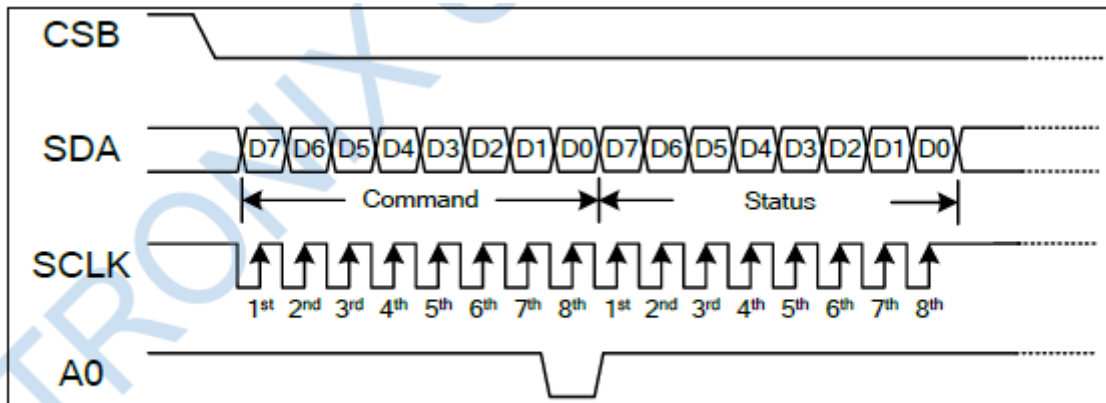

Read Status Operation of 4-Line SPI

Document Title	HSD042GPW1-90000D-MX Preliminary Specification	Page No.	14/21
Document No.	DC	Revision	1.0

6.2.2 Power On/Off Sequence

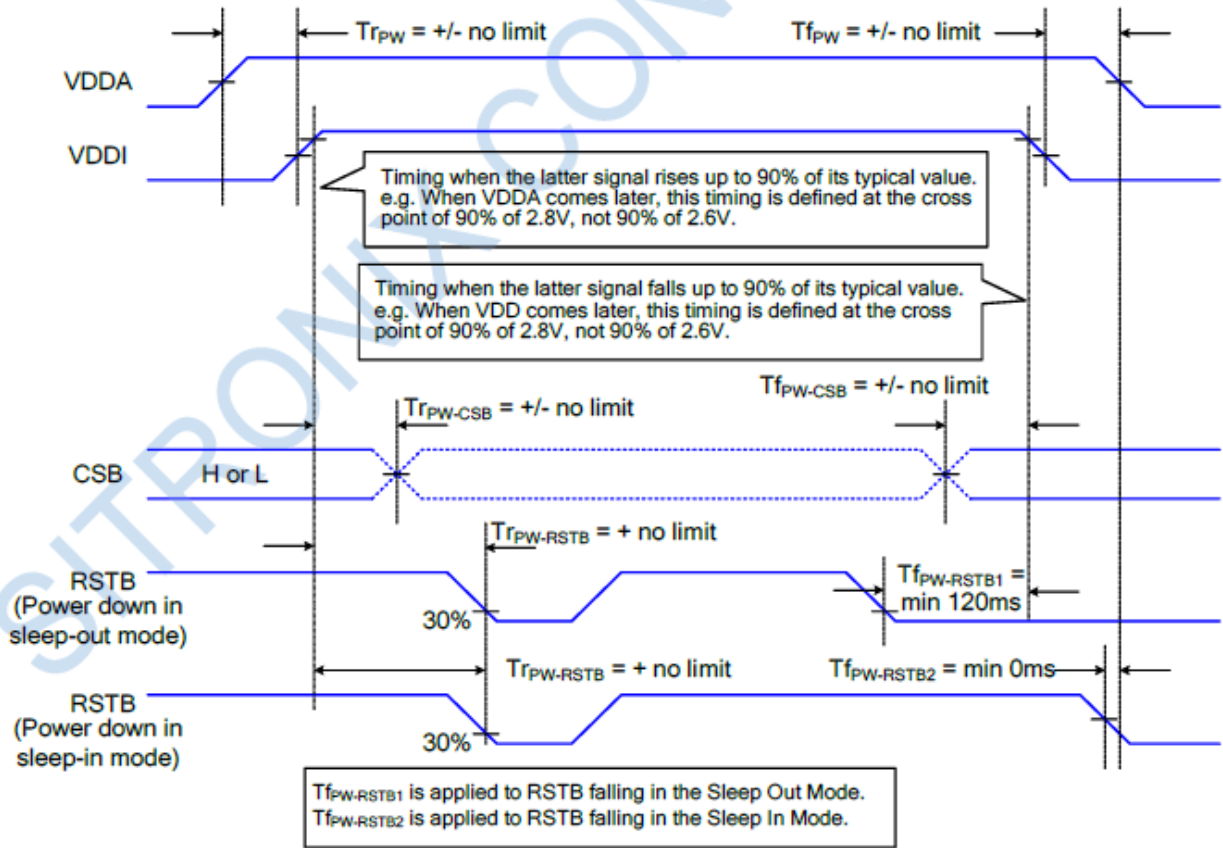

Document Title	HSD042GPW1-90000D-MX Preliminary Specification	Page No.	15/21
Document No.	DC	Revision	1.0

6.3 Front Light Unit

7	Parameter	Symbol	Min	Typ	Max	Units	Condition
	LED Current	I _L	--	20	--	mA	Ta=25°C
	LED Voltage	V _F		6.0		Volt	Ta=25°C
	LED Life-Time	N/A		--	--	Hour	Ta=25°C Note (2)

Note (1) LED life time (Hr) can be defined as the time in which it continues to operate under the condition: Ta=25±3 °C, typical I_L value indicated in the above table until the brightness becomes less than 50%.

Note (2) The “LED life time” is defined as the module brightness decrease to 50% original brightness at Ta=25°C. and I_L=100mA. The LED lifetime could be decreased if operating I_L is larger than 100mA. The constant current driving method is suggested.

Note (3) LED Light Bar Circuit

Document Title	HSD042GPW1-90000D-MX Preliminary Specification	Page No.	16/21
Document No.	DC	Revision	1.0

7.0 RELIABILITY TEST ITEMS

No.	Item	Conditions	Remark
1	High Temperature Storage	Ta=+80°C, 240hrs	1, 2, 3
2	Low Temperature Storage	Ta=-30°C, 240hrs	1, 2, 3
3	High Temperature Operation	Ta=+70°C, 240hrs	1, 2, 3
4	Low Temperature Operation	Ta=-20°C, 240hrs	1, 2, 3,
5	High Temperature and High Humidity (operation)	Ta=+60°C, 90%RH, 240hrs	1, 2, 3
6	Thermal Cycling Test (non operation)	-30°C(30min)→+80°C(30min),100 cycles	1, 2, 3

Note1: There is no display function NG issue occurred, all the cosmetic specification is judged before the reliability stress.

Note2: The test result shall be evaluated after the sample has been left at room temperature and humidity for 2 hours without load. No condensation shall be accepted. The sample shall be free from defects:

(Air bubble in the LCD 、 Seal leak 、 Non-display 、 Missing segments 、 Glass crack).

Note3: The test condition definition panel's surface temperature.

Document Title	HSD042GPW1-90000D-MX Preliminary Specification	Page No.	18/21
Document No.	DC	Revision	1.0

9.0 LOT MARK

9.1 Lot Mark

1	2	3	4	5	6	7	8	9	10	11	12	13	14	15
---	---	---	---	---	---	---	---	---	----	----	----	----	----	----

Code 1,2,3: HannStar internal flow control code.

Code 4: production location.

Code 5: production category

Code 6: production year

Code 7: production month.

Code 8,9,10,11,12,13,14,15: serial number.

Note (1) Production Year: Code 8 is defined by the last number of the year, for example

Year	2019	2020	2021	2022	2023	2024	2025	2026	2027	2028
Mark	9	0	1	2	3	4	5	6	7	8

Note (2) Production Month

Month	Jan.	Feb.	Mar.	Apr.	May.	Jun.	Jul.	Aug.	Sep.	Oct.	Nov.	Dec.
Mark	1	2	3	4	5	6	7	8	9	A	B	C

9.2 Detail of Lot Mark

(1) Below label is attached on FPC.

(2) The detail of Lot Mark is attached as below.

(3) This is subject to change without prior notice.





Document Title	HSD042GPW1-90000D-MX Preliminary Specification	Page No.	19/21
Document No.	DC	Revision	1.0

10.0 PACKAGE SPECIFICATION

10.1 Packing form

TBD

10.2 Packing assembly drawings

TBD

Document Title	HSD042GPW1-90000D-MX Preliminary Specification	Page No.	20/21
Document No.	DC	Revision	1.0

11.0 GENERAL PRECAUTION

11.1 Use Restriction

This product is not authorized for use in life supporting systems, aircraft navigation control systems, military systems and any other application where performance failure could be life-threatening or otherwise catastrophic.

11.2 Disassembling or Modification

Do not disassemble or modify the module. It may damage sensitive parts inside LCD module, and may cause scratches or dust on the display. HannStar does not warrant the module, if customers disassemble or modify the module.

11.3 Breakage of LCD Panel

11.3.1. If LCD panel is broken and liquid crystal spills out, do not ingest or inhale liquid crystal, and do not contact liquid crystal with skin.

11.3.2. If liquid crystal contacts mouth or eyes, rinse out with water immediately.

11.3.3. If liquid crystal contacts skin or cloths, wash it off immediately with alcohol and rinse thoroughly with water.

11.3.4. Handle carefully with chips of glass that may cause injury, when the glass is broken.

11.4 Electric Shock

11.4.1. Disconnect power supply before handling LCD module.

11.4.2. Do not pull or fold the LED cable.

11.4.3. Do not touch the parts inside LCD modules and the fluorescent LED's connector or cables in order to prevent electric shock.

11.5 Absolute Maximum Ratings and Power Protection Circuit

11.5.1. Do not exceed the absolute maximum rating values, such as the supply voltage variation, input voltage variation, variation in parts' parameters, environmental temperature, etc., otherwise LCD module may be damaged.

11.5.2. Please do not leave LCD module in the environment of high humidity and high temperature for a long time.

11.5.3. It's recommended to employ protection circuit for power supply.

11.6 Operation

11.6.1 Do not touch, push or rub the polarizer with anything harder than HB pencil lead.

11.6.2 Use fingerstalls of soft gloves in order to keep clean display quality, when persons handle the LCD module for incoming inspection or assembly.

11.6.3 When the surface is dusty, please wipe gently with absorbent cotton or other soft material.



Document Title	HSD042GPW1-90000D-MX Preliminary Specification	Page No.	21/21
Document No.	DC	Revision	1.0

11.6.4 Wipe off saliva or water drops as soon as possible. If saliva or water drops contact with polarizer for a long time, they may causes deformation or color fading.

11.6.5 When cleaning the adhesives, please use absorbent cotton wetted with a little petroleum benzine or other adequate solvent.

11.7 Static Electricity

11.7.1 Protection film must remove very slowly from the surface of LCD module to prevent from electrostatic occurrence.

11.7.2 Because LCD module use CMOS-IC on circuit board and TFT-LCD panel, it is very weak to electrostatic discharge. Please be careful with electrostatic discharge. Persons who handle the module should be grounded through adequate methods.

11.8 Strong Light Exposure

The module shall not be exposed under strong light such as direct sunlight. Otherwise, display characteristics may be changed.

11.9 Disposal

When disposing LCD module, obey the local environmental regulations.



ALL TECHNOLOGIES. ALL COMPETENCIES. ONE SPECIALIST.



DATA MODUL AG
Landsberger Straße 322
DE-80687 Munich
Phone: +49-89-56017-0

DATA MODUL WEIKERSHEIM GMBH
Lindenstraße 8
DE-97990 Weikersheim
Phone: +49-7934-101-0



More information and worldwide locations can be found at

www.data-modul.com