



SPECIFICATION



HSD080JHW3-A13

8" - HD - LVDS

Version: 1.0

Date: 04.05.2023

Note: This specification is subject to change without prior notice

Document Title	HSD080JHW3-A13 Product Information for DATA MODUL	Page No.	1 / 26
Document No.		Revision	1.0

TO : DATA MODUL

Date : May., 04, 2023

HannStar Product Information

(Formal)

8" Color TFT-LCD Module

Model: **HSD080JHW3-A13**

Note:

- (1) Please contact HannStar Display Corp. before designing your product based on this module specification.
- (2) The information contained herein is presented merely to indicate the characteristics and performance of our products. No responsibility is assumed by HannStar for any intellectual property claims or other problems that may result from application based on the module described herein.
- (3) The mark “ ** ” of Model means sub-model code.
- (4) This specification contains bracketed details“(Number)”, which are tentative specifications.

If there is any change, the specifications will be updated in the next stage.

Document Title	HSD080JHW3-A13 Product Information for DATA MODUL	Page No.	2 / 26
Document No.		Revision	1.0

Record of Revisions

Rev.	Date	Sub-Model	Description of change
1.0	May.,04, 2023	-A13	Formal Product Information was first released.

The information contained in this document is the exclusive property of HannStar Display Corporation. It shall not be disclosed, distributed or reproduced in whole or in part without written permission of HannStar Display Corporation.

Document Title	HSD080JHW3-A13 Product Information for DATA MODUL	Page No.	3 / 26
Document No.		Revision	1.0

Contents

1.0	GENERAL DESCRIPTION	4
2.0	ABSOLUTE MAXIMUM RATINGS	5
3.0	OPTICAL CHARACTERISTICS	6
4.0	BLOCK DIAGRAM.....	10
5.0	INTERFACE PIN CONNECTION	12
6.0	ELECTRICAL CHARACTERISTICS.....	14
7.0	RELIABILTY TEST ITEMS.....	20
8.0	OUTLINE DIMENSION.....	21
9.0	LOT MARK	23
10.0	PACKAGE SPECIFICATION	24
11.0	GENERAL PRECAUTION	25

Document Title	HSD080JHW3-A13 Product Information for DATA MODUL	Page No.	4 / 26
Document No.		Revision	1.0

1.0 GENERAL DESCRIPTION

1.1 Introduction

HannStar Display model HSD080JHW3-A13 is a color active matrix thin film transistor (TFT) liquid crystal display (LCD) that uses amorphous silicon TFT as a switching device. This model is composed of a TFT LCD panel, a driving circuit and a back light system. This TFT LCD has a 8" (16:9) inch diagonally measured active display area with HD (1280 horizontal by 720 vertical pixel) resolution.

1.2 Features

- 8 (16:9 diagonal) inch configuration
- 16.7M color by 8 bit
- ROHS / Halogen Free Compliance

1.3 Applications

- Automotive

1.4 General information

Item	Specification	Unit	
Outline Dimension	192.8(H) x 116.9(V) x 6.4 (Typ.)	mm	
Display area	176.64(H) x 99.36(V)	mm	
Number of Pixel	1280 RGB (H) x 720(V)	pixels	
Pixel pitch	0.138(H) x 0.138(V)	mm	
Pixel arrangement	RGB Vertical stripe		
Display mode	Normally Black (IPS-pro)		
NTSC	75 (Typ.)	%	
Surface treatment	Hard-Coating (3H)		
Weight	220(Max.)	g	
Back-light	21pcs(7S3P)		
Power Consumption	Logic System	1.65(Max) @ White Pattern & 60Hz	W
	B/L System	6.069(Max.)	W

1.5 Mechanical Information

Item	Min.	Typ.	Max.	Unit	
Module Size	Horizontal (H)	192.5	192.8	193.1	mm
	Vertical (V)	116.6	116.9	117.2	mm
	Depth (D)	6.1	6.4	6.7	mm
Weight	180	200	220	g	

Document Title	HSD080JHW3-A13 Product Information for DATA MODUL	Page No.	5 / 26
Document No.		Revision	1.0

2.0 ABSOLUTE MAXIMUM RATINGS

2.1 Electrical Absolute Rating

2.1.1 TFT LCD Module

Parameters	Symbol	Min.	Max.	Unit	Note
Power Supply voltage	DVDD	-0.3	4	V	

2.2 Environment Absolute Rating

Item	Symbol	Min.	Max.	Unit	Note
Operating Temperature	T _{opa}	-40	85	°C	240hr
Storage Temperature	T _{stg}	-40	90	°C	240hr

Document Title	HSD080JHW3-A13 Product Information for DATA MODUL	Page No.	6 / 26
Document No.		Revision	1.0

3.0 OPTICAL CHARACTERISTICS

3.1 Optical specification

Item	Symbol	Condition	Min.	Typ.	Max.	Unit	Note
Contrast	CR		800	1000	—		(1)(2)
Response time	Rising	T_{R+} T_F	—	20	25	msec	(1)(3)
	Falling						
White luminance (Center)	Y_L		600	800	—	cd/m ²	(1)(4) ($I_L=255mA$)
Color chromaticity (CIE1931)	White	W_x	$\Theta=0$ Normal viewing angle	0.270	0.310	0.350	(1)(4)
		W_y		0.290	0.330	0.370	
	Red	R_x		0.605	0.645	0.685	
		R_y		0.294	0.334	0.374	
	Green	G_x		0.262	0.302	0.342	
		G_y		0.576	0.616	0.656	
	Blue	B_x		0.109	0.149	0.189	
		B_y		0.019	0.059	0.099	
Viewing angle	Hor.	Θ_L	CR>10	75	85	—	
		Θ_R		75	85	—	
	Ver.	Θ_U		75	85	—	
		Θ_D		75	85	—	
Brightness uniformity	B_{UNI}	$\Theta=0$	70	80	—	%	(5)
Optima View Direction	Free						(6)

3.2 Measuring Condition

- Measuring surrounding : dark room
- LED current I_L : 255mA
- Ambient temperature : 25±2°C
- 15min. warm-up time.

Document Title	HSD080JHW3-A13 Product Information for DATA MODUL	Page No.	7 / 26
Document No.		Revision	1.0

3.3 Measuring Equipment

- FPM520 of Westar Display technologies, INC., which utilized SR-3 for Chromaticity and BM-5A for other optical characteristics.

- Measuring spot size : 20 ~ 21 mm

Note (1) Definition of Viewing Angle:

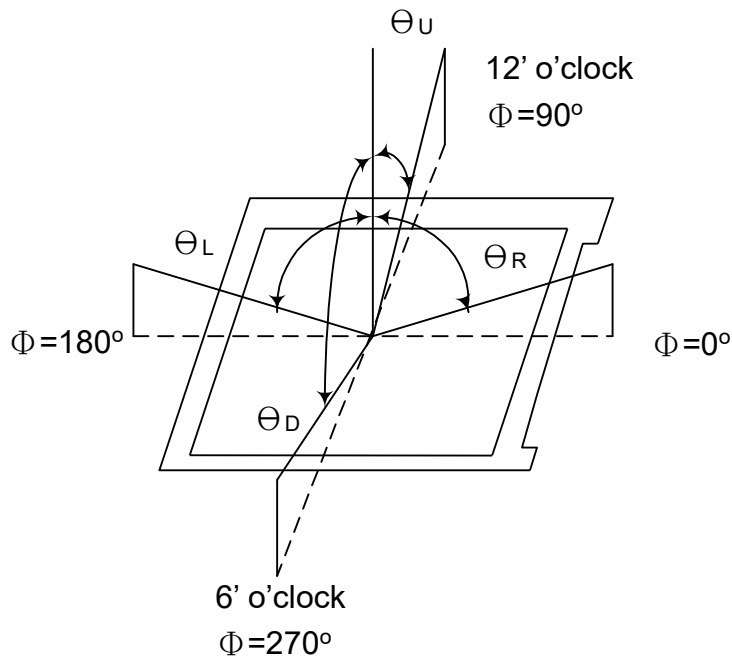

Note (2) Definition of Contrast Ratio (CR) :
measured at the center point of panel

$$CR = \frac{\text{Luminance with all pixels white}}{\text{Luminance with all pixels black}}$$

Document Title	HSD080JHW3-A13 Product Information for DATA MODUL	Page No.	8 / 26
Document No.		Revision	1.0

Note (3) Definition of Response Time : Sum of T_R and T_F

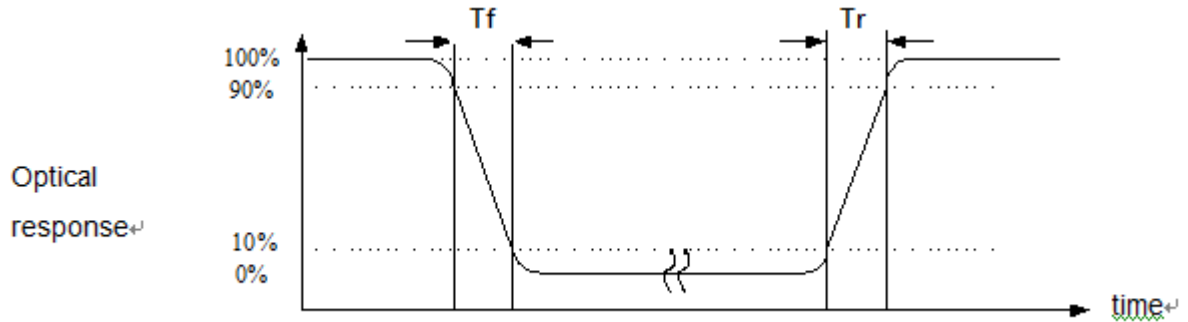

Note (4) Definition of optical measurement setup

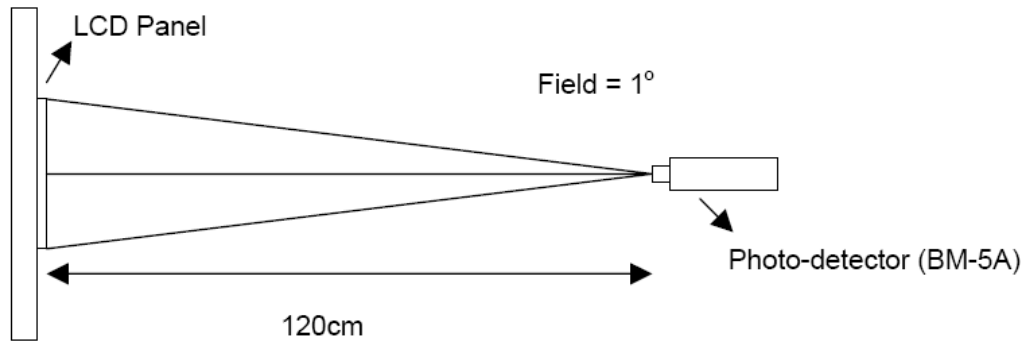

Document Title	HSD080JHW3-A13 Product Information for DATA MODUL	Page No.	9 / 26
Document No.		Revision	1.0

Note (5) Definition of brightness uniformity

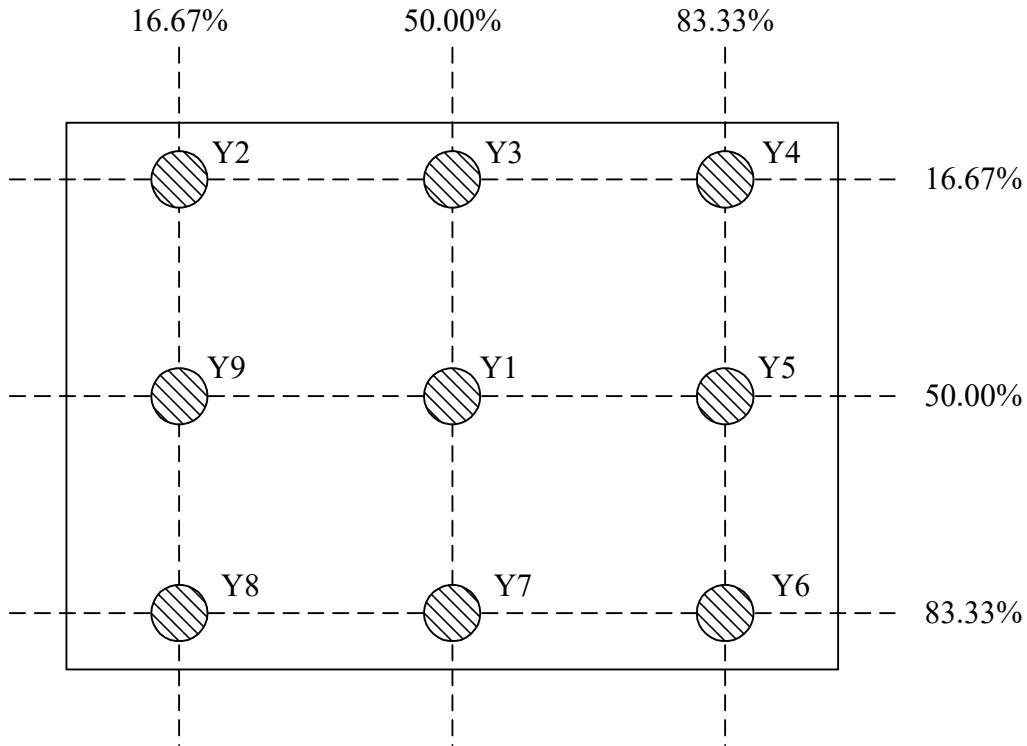

$$\text{Luminance uniformity} = \frac{(\text{Min Luminance of 9 points})}{(\text{Max Luminance of 9 points})} \times 100\%$$

Note (6) : Rubbing Direction (The different Rubbing Direction will cause the different optima view direction).

Document Title	HSD080JHW3-A13 Product Information for DATA MODUL	Page No.	10 / 26
Document No.		Revision	1.0

4.0 BLOCK DIAGRAM

4.1 TFT LCD Module:

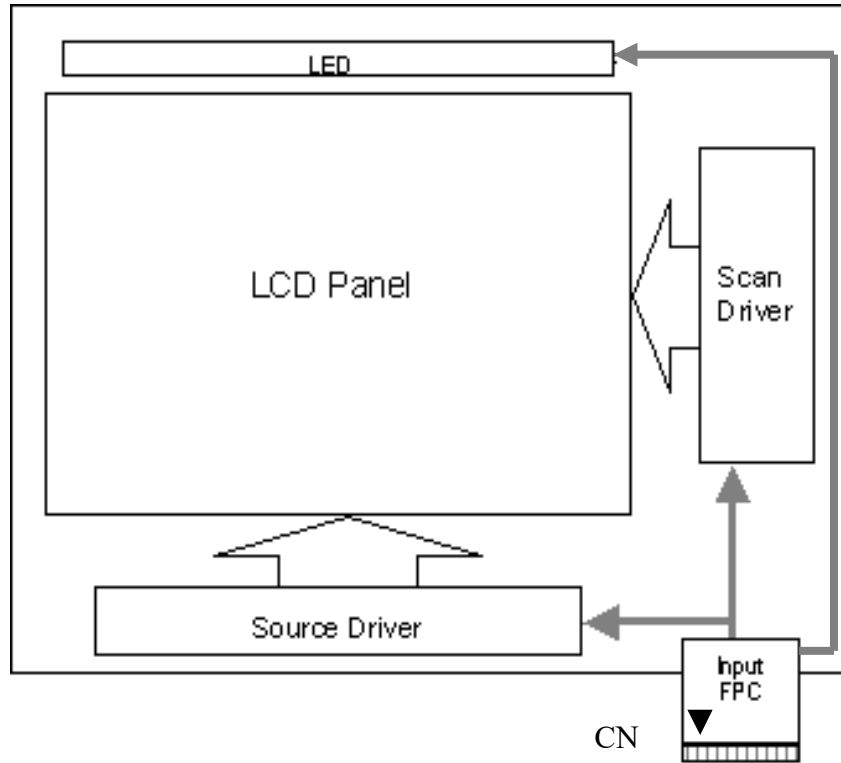

4.2 Pixel Format

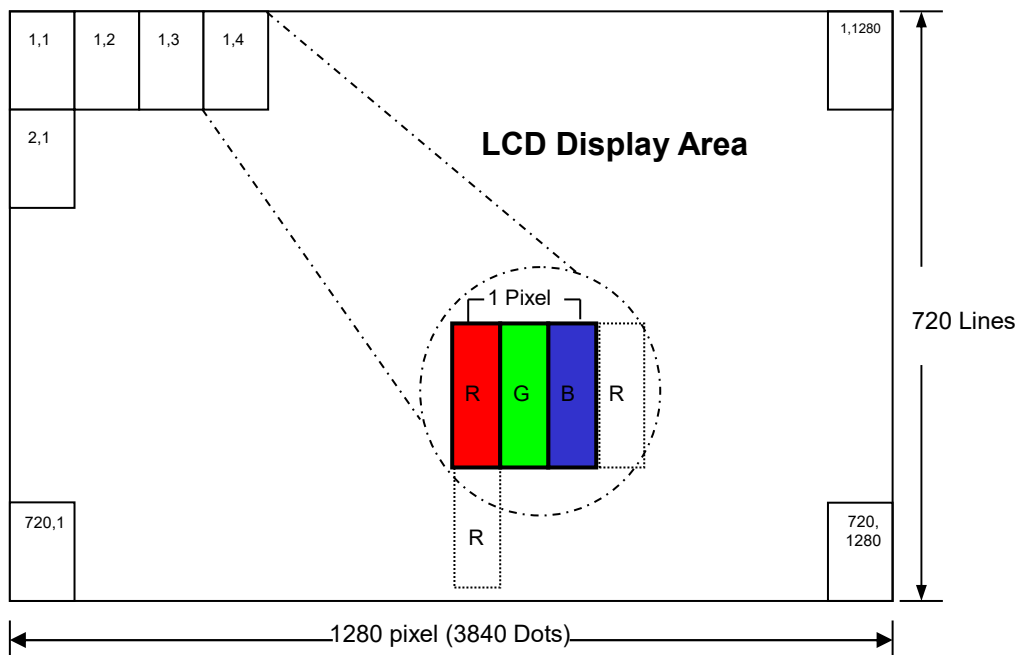

Document Title	HSD080JHW3-A13 Product Information for DATA MODUL	Page No.	11 / 26
Document No.		Revision	1.0

4.3 Relationship Between Displayed Color and Input

	Display	MSB				LSB				MSB				LSB				MSB				LSB				Gray scale Level		
		R7	R6	R5	R4	R3	R2	R1	R0	G7	G6	G5	G4	G3	G2	G1	G0	B7	B6	B5	B4	B3	B2	B1	B0			
Basic color	Black	L	L	L	L	L	L	L	L	L	L	L	L	L	L	L	L	L	L	L	L	L	L	L	L	L	L	-
	Blue	L	L	L	L	L	L	L	L	L	L	L	L	L	L	L	L	H	H	H	H	H	H	H	H	H	H	-
	Green	L	L	L	L	L	L	L	L	H	H	H	H	H	H	H	H	L	L	L	L	L	L	L	L	L	L	-
	Light Blue	L	L	L	L	L	L	L	L	H	H	H	H	H	H	H	H	H	H	H	H	H	H	H	H	H	H	-
	Red	H	H	H	H	H	H	H	H	L	L	L	L	L	L	L	L	L	L	L	L	L	L	L	L	L	L	-
	Purple	H	H	H	H	H	H	H	H	L	L	L	L	L	L	L	L	H	H	H	H	H	H	H	H	H	H	-
	Yellow	H	H	H	H	H	H	H	H	H	H	H	H	H	H	H	H	L	L	L	L	L	L	L	L	L	L	-
	White	H	H	H	H	H	H	H	H	H	H	H	H	H	H	H	H	H	H	H	H	H	H	H	H	H	H	-
Gray scale of Red	Black	L	L	L	L	L	L	L	L	L	L	L	L	L	L	L	L	L	L	L	L	L	L	L	L	L	L	L0
	Dark ↑ ↓ Light	L	L	L	L	L	L	L	H	L	L	L	L	L	L	L	L	L	L	L	L	L	L	L	L	L	L	L1
		L	L	L	L	L	L	L	H	L	L	L	L	L	L	L	L	L	L	L	L	L	L	L	L	L	L	L2
		:	:	:	L3...L251																							
		H	H	H	H	H	H	L	L	L	L	L	L	L	L	L	L	L	L	L	L	L	L	L	L	L	L	L252
	H	H	H	H	H	H	L	H	L	L	L	L	L	L	L	L	L	L	L	L	L	L	L	L	L	L	L253	
	H	H	H	H	H	H	H	L	L	L	L	L	L	L	L	L	L	L	L	L	L	L	L	L	L	L	L254	
	Red	H	H	H	H	H	H	H	L	L	L	L	L	L	L	L	L	L	L	L	L	L	L	L	L	L	Red L255	
Gray scale of Green	Black	L	L	L	L	L	L	L	L	L	L	L	L	L	L	L	L	L	L	L	L	L	L	L	L	L	L	L0
	Dark ↑ ↓ Light	L	L	L	L	L	L	L	L	L	L	L	L	L	L	L	H	L	L	L	L	L	L	L	L	L	L	L1
		L	L	L	L	L	L	L	L	L	L	L	L	L	L	H	L	L	L	L	L	L	L	L	L	L	L	L2
		:	:	:	L3...L251																							
		L	L	L	L	L	L	L	L	H	H	H	H	H	L	L	L	L	L	L	L	L	L	L	L	L	L252	
	L	L	L	L	L	L	L	L	H	H	H	H	H	L	H	L	L	L	L	L	L	L	L	L	L	L253		
	L	L	L	L	L	L	L	L	H	H	H	H	H	H	L	L	L	L	L	L	L	L	L	L	L	L254		
	Green	L	L	L	L	L	L	L	H	H	H	H	H	H	H	L	L	L	L	L	L	L	L	L	L	Green L255		
Gray scale of Blue	Black	L	L	L	L	L	L	L	L	L	L	L	L	L	L	L	L	L	L	L	L	L	L	L	L	L	L	L0
	Dark ↑ ↓ Light	L	L	L	L	L	L	L	L	L	L	L	L	L	L	L	L	L	L	L	L	L	L	L	L	H	L	L1
		L	L	L	L	L	L	L	L	L	L	L	L	L	L	L	L	L	L	L	L	L	L	L	H	L	L	L2
		:	:	:	L3...L251																							
		L	L	L	L	L	L	L	L	L	L	L	L	L	L	L	L	H	H	H	H	H	L	L	L	L	L	L252
	L	L	L	L	L	L	L	L	L	L	L	L	L	L	L	L	H	H	H	H	H	L	H	L	L	L	L253	
	L	L	L	L	L	L	L	L	L	L	L	L	L	L	L	L	H	H	H	H	H	H	L	L	L	L	L254	
	Blue	L	L	L	L	L	L	L	L	L	L	L	L	L	L	L	H	H	H	H	H	H	H	H	H	H	Blue L255	
Gray scale of White & Black	Black	L	L	L	L	L	L	L	L	L	L	L	L	L	L	L	L	L	L	L	L	L	L	L	L	L	L	L0
	Dark ↑ ↓ Light	L	L	L	L	L	L	L	H	L	L	L	L	L	L	L	H	L	L	L	L	L	L	L	L	H	L	L1
		L	L	L	L	L	L	L	H	L	L	L	L	L	L	H	L	L	L	L	L	L	L	L	H	L	L	L2
		:	:	:	L3...L251																							
		H	H	H	H	H	L	L	H	H	H	H	L	L	H	H	H	H	L	L	H	H	H	H	L	L	L252	
	H	H	H	H	H	L	H	H	H	H	H	L	H	H	H	H	H	L	H	H	H	H	H	L	H	L253		
	H	H	H	H	H	H	L	H	H	H	H	H	L	H	H	H	H	H	L	H	H	H	H	H	L	L254		
	White	H	H	H	H	H	H	H	H	H	H	H	H	H	H	H	H	H	H	H	H	H	H	H	H	White L255		

Document Title	HSD080JHW3-A13 Product Information for DATA MODUL	Page No.	12 / 26
Document No.		Revision	1.0

5.0 INTERFACE PIN CONNECTION

5.1 FPC Pin Assignment:

FPC connector is used for electronics interface. The recommended model is FH28D-30S-0.5SH manufactured by HIROSE.

Pin No.	Symbol	I/O	Description
1	BIST	I	Normal operation/BIST pattern select. BIST="1": BIST mode. BIST="0": Normal operation.
2	DVDD	PI	Digital power (3.3V)
3	DVDD	PI	Digital power (3.3V)
4	GND	G	ground
5	RESETB	I	Global reset pin. Active low to enter reset state. Suggest to connecting with an RC reset circuit for stability. Normally pull high. (R=10KΩ · C=1μF)
6	STBYB	I	Standby mode setting pin. active low. Timing controller, output buffer, DAC and power circuit all of when STBYB is low. Suggest to connecting with an RC reset circuit for stability. Normally pull high. (R=10KΩ · C=1μF)
7	GND	G	ground
8	SPI_SDA	NC	Serial interface address and data input/output for SPI interface
9	SPI_SCL	NC	Serial interface clock input for SPI interface
10	SPI_CSB	NC	Serial interface chip enable signal for SPI interface
11	GND	G	ground
12	TB	I	Up / down display control TB="1": Up --> Down. TB="0": Down --> Up.
13	RL	I	Left or right display control RL="1": Left --> right. RL="0": right --> Left.
14	GND	G	Digital ground
15	NIND0	I	Negative LVDS differential data input
16	PIND0	I	Positive LVDS differential data input
17	GND	G	Digital ground
18	NIND1	I	Negative LVDS differential data input
19	PIND1	I	Positive LVDS differential data input
20	GND	G	Digital ground
21	NIND2	I	Negative LVDS differential data input

Document Title	HSD080JHW3-A13 Product Information for DATA MODUL	Page No.	13 / 26
Document No.		Revision	1.0

22	PIND2	I	Positive LVDS differential data input
23	GND	G	Digital ground
24	NINC	I	Negative LVDS differential clock input
25	PINC	I	Positive LVDS differential clock input
26	GND	G	Digital ground
27	NIND3	I	Negative LVDS differential data input
28	PIND3	I	Positive LVDS differential data input
29	GND	G	ground
30	NC	NC	OTP pin only for HSD, power input for OTP programming (8.6V), keep floating when not programming OTP

5.2 LED Board Pin Assignment:

FPC connector is used for LED FPC. The recommended model is FH28D-10S-0.5SH manufactured by HIROSE.

Pin NO.	Function	I/O	Remark
1	ANODE1	P	LED power supply
2	ANODE2	P	LED power supply
3	ANODE3	P	LED power supply
4	NC	-	No Connection
5	NTC+	P	Thermistor Input Power
6	NTC-	O	Thermistor Feedback Channel
7	NC	-	No Connection
8	CATHODE3	O	Light-bar Feedback Channel 3
9	CATHODE2	O	Light-bar Feedback Channel 2
10	CATHODE1	O	Light-bar Feedback Channel 1

Document Title	HSD080JHW3-A13 Product Information for DATA MODUL	Page No.	14 / 26
Document No.		Revision	1.0

6.0 ELECTRICAL CHARACTERISTICS

6.1 TFT LCD Module

Item	Symbol	Min.	Typ.	Max.	Unit	Note
Supply Voltage	VDD	3.0	3.3	3.6	V	
Input signal voltage	V _{IH}	0.7 VDD	-	VDD	V	
	V _{IL}	GND	-	GND+0.3	V	
Current of power supply	IDD	-	400	500	mA	VDD =3.3V / Note (1)

Note :

(1) : @ White Pattern & 60Hz ◦

6.2 Switching Characteristics for LVDS Receiver

LVDS mode:

Parameter	Symbol	Min.	Typ.	Max.	Unit	Condition
Input voltage range (signaled-end)	RXVIN	0	-	VDD-1.2	V	-
Differential Input common Mode voltage	RXVCM	VID /2	-	VDD-1.2- VID /2	V	-
Differential Input voltage	VID	0.2	-	0.6	V	-
Differential Input leakage Current	RVXliz	-10	-	10	uA	-

Single-end signals

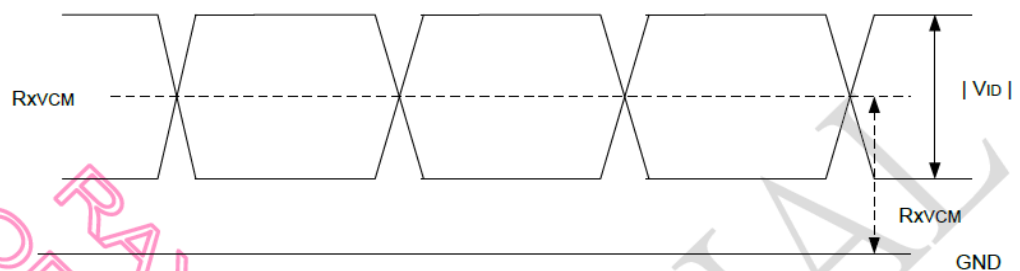

Document Title	HSD080JHW3-A13 Product Information for DATA MODUL	Page No.	15 / 26
Document No.		Revision	1.0

6.3 Bit LVDS input

6.3.1 8bit LVDS input (VESA Format DE mode)

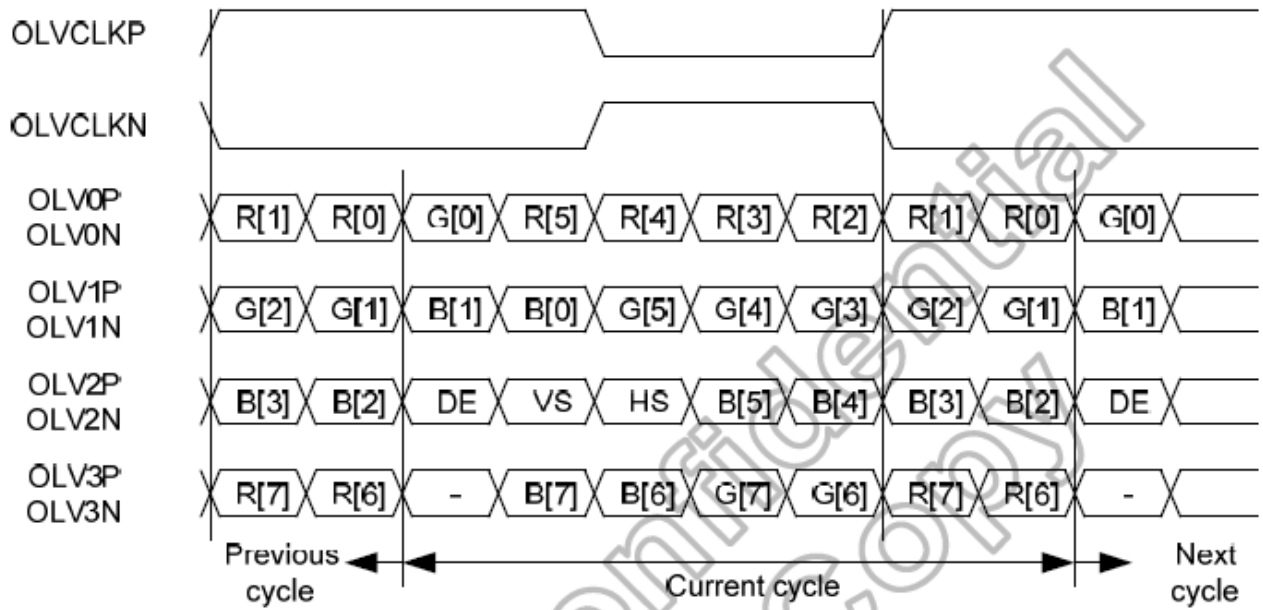

Document Title	HSD080JHW3-A13 Product Information for DATA MODUL	Page No.	16 / 26
Document No.		Revision	1.0

6.4 Interface Timing (DE mode)

Item	Symbol	Min.	Typ.	Max.	Unit
Frame Rate	--	58	60	62	Hz
Vertical Total Time	TV	726	738	744	line
Vertical Display Time	TVD	720			line
Vertical Blanking Time	TVB	6	18	24	line
Horizontal Total Time	TH	1340	1344	1348	clock
Horizontal Display Time	THD	1280			clock
Horizontal Blanking Time	THB	60	64	68	clock
Clock Rate	1/ TClock	58.2	59.5	60.3	MHz

Timing Diagram of Interface Signal (DE mode)

1. Vertical

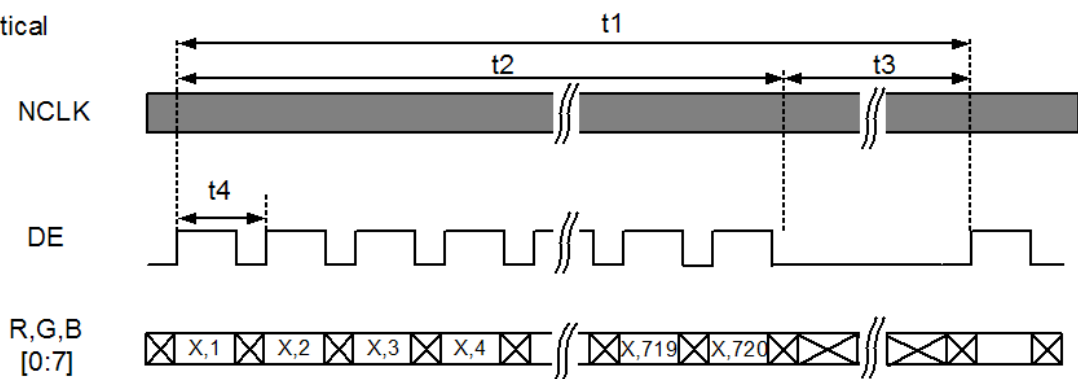

2. Horizontal

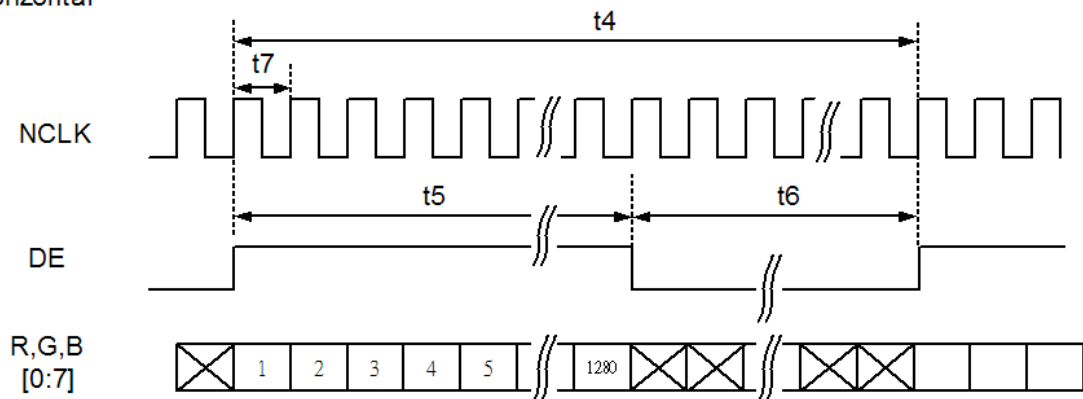

Document Title	HSD080JHW3-A13 Product Information for DATA MODUL	Page No.	17 / 26
Document No.		Revision	1.0

6.5 Power On / Off Sequence

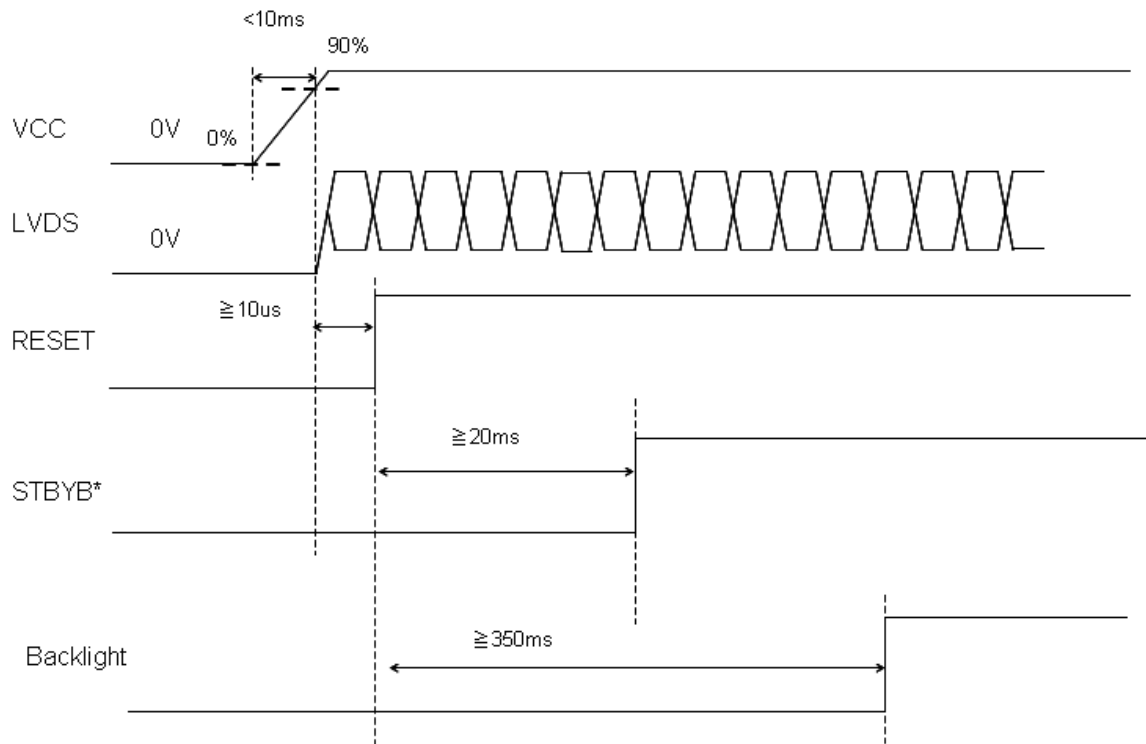

Document Title	HSD080JHW3-A13 Product Information for DATA MODUL	Page No.	18 / 26
Document No.		Revision	1.0

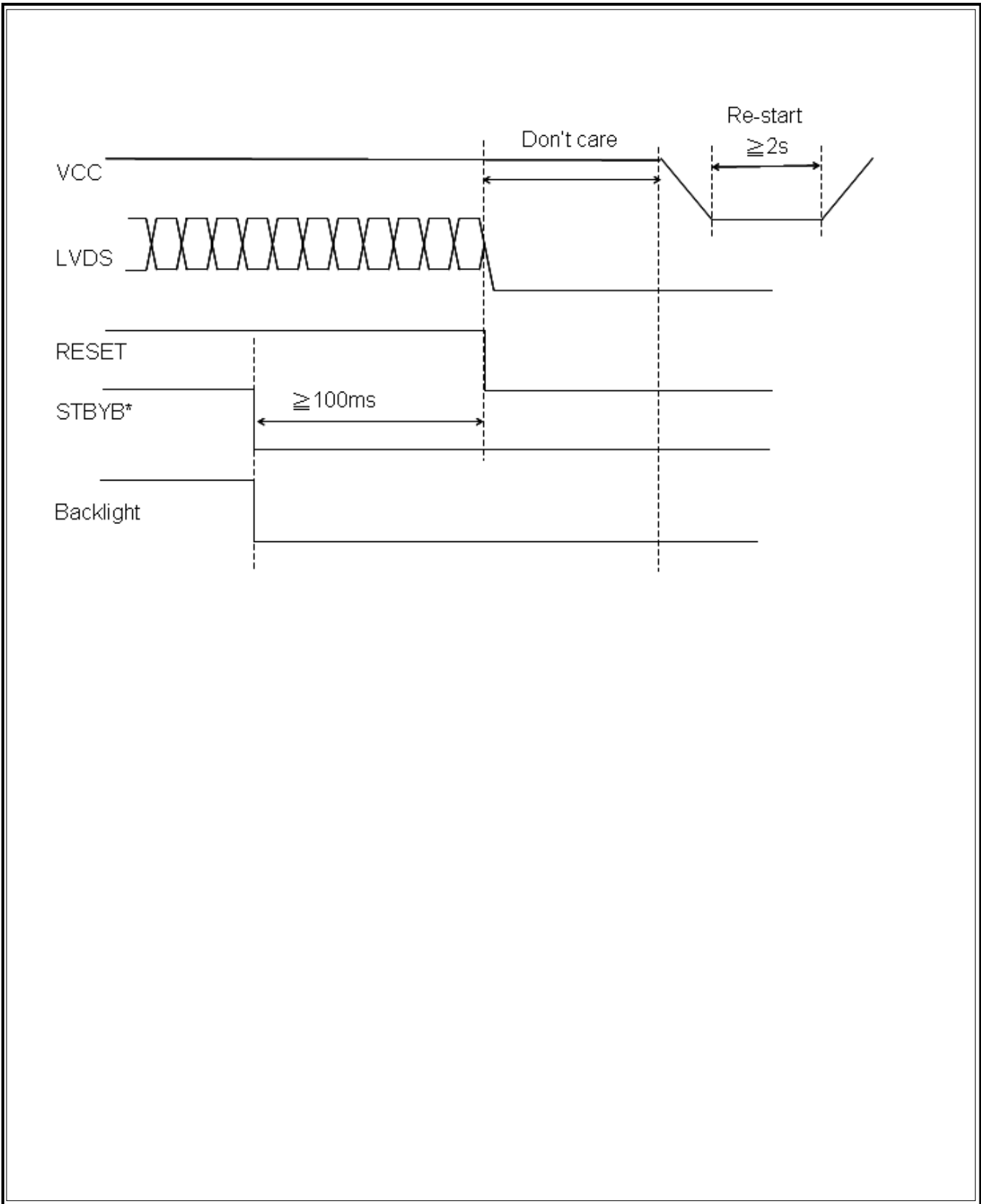

The information contained in this document is the exclusive property of HannStar Display Corporation. It shall not be disclosed, distributed or reproduced in whole or in part without written permission of HannStar Display Corporation.

Document Title	HSD080JHW3-A13 Product Information for DATA MODUL	Page No.	19 / 26
Document No.		Revision	1.0

6.6 Backlight Unit

Parameter	Symbol	Min	Typ	Max	Units	Condition
LED Current	I_L	--	255	--	mA	$T_a=25^\circ\text{C}$
LED Voltage	V_F	--		23.8	Volt	$T_a=25^\circ\text{C}$
LED Life-Time	N/A	30,000	--	--	Hour	$T_a=25^\circ\text{C}$ $I_L=255\text{mA}$ Note (2)

Note (1) LED life time (Hr) can be defined as the time in which it continues to operate under the condition: $T_a=25\pm 3^\circ\text{C}$, typical I_L value indicated in the above table until the brightness becomes less than 50%.

Note (2) The "LED life time" is defined as the module brightness decrease to 50% original brightness at $T_a=25^\circ\text{C}$ and $I_L=255\text{mA}$. The LED lifetime could be decreased if operating I_L is larger than 255mA. The constant current driving method is suggested.

Note (3) LED Light Bar Circuit

Light-Bar LED (7s3p)

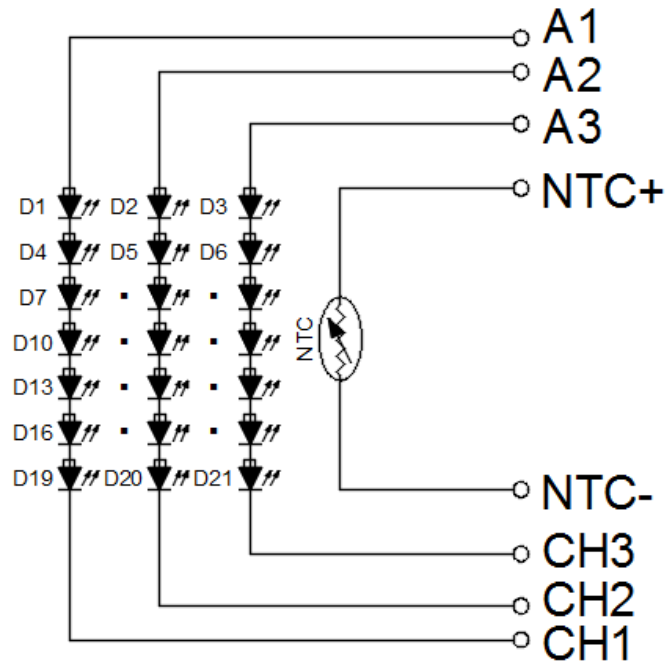

Document Title	HSD080JHW3-A13 Product Information for DATA MODUL	Page No.	20 / 26
Document No.		Revision	1.0

7.0 RELIABILITY TEST ITEMS

No.	Item	Conditions	Remark
1	High Temperature Storage	Ta=+90oC, 240hrs	1,2,3
2	Low Temperature Storage	Ta=-40oC, 240hrs	1,2,3
3	High Temperature Operation	Ta=+85oC, 240hrs	1,2,3
4	Low Temperature Operation	Ta=-40oC, 240hrs	1,2,3
5	High Temperature and High Humidity (operation)	Ta=+60oC, 90%RH, 240hrs	1,2,3
6	Thermal Cycling Test (non operation)	-40oC(30min) → +85oC(30min), 100 cycles	1,2,3
7	Electrostatic Discharge	±200V,200pF(0Ω) 1 time/connector	
8	Vibration	1.Random: 1.04G, 5~500Hz, XYZ, 30min/each direction 2.Sine: Freq. Range: 8~33.3Hz, Stoke: 1.3mm Sweep: 2.9G, 33.3~400 X/Z: 2hrs, Y:4hrs	
9	Shock	Half-Sine, 100G, 6ms, ±XYZ, 1time	
10	Vibration (with carton)	Random: 0.015G ² /Hz, 5~200Hz -6dB/Octave, 200~400Hz XYZ 各方向 2hrs	
11	Drop (with carton)	Drop height condition, basis on the product weight and Follow QB100-0027 1 corner, 3 edges, 6 surfaces	

Note1: There is no display function NG issue occurred, all the cosmetic specification is judged before the reliability stress.

Note2: All of the function & cosmetic Judgment basis base on IIS Spec. at room temperature. (The tested module must have enough recovery time at least 2 hours at room temperature.)

Note3: The test condition definition panel's surface temperature.

Note4: Before CL/TP bonding, LCM must pre baking by 80°C/8hr

Document Title	HSD080JHW3-A13 Product Information for DATA MODUL	Page No.	21 / 26
Document No.		Revision	1.0

8.0 OUTLINE DIMENSION

Unit : mm

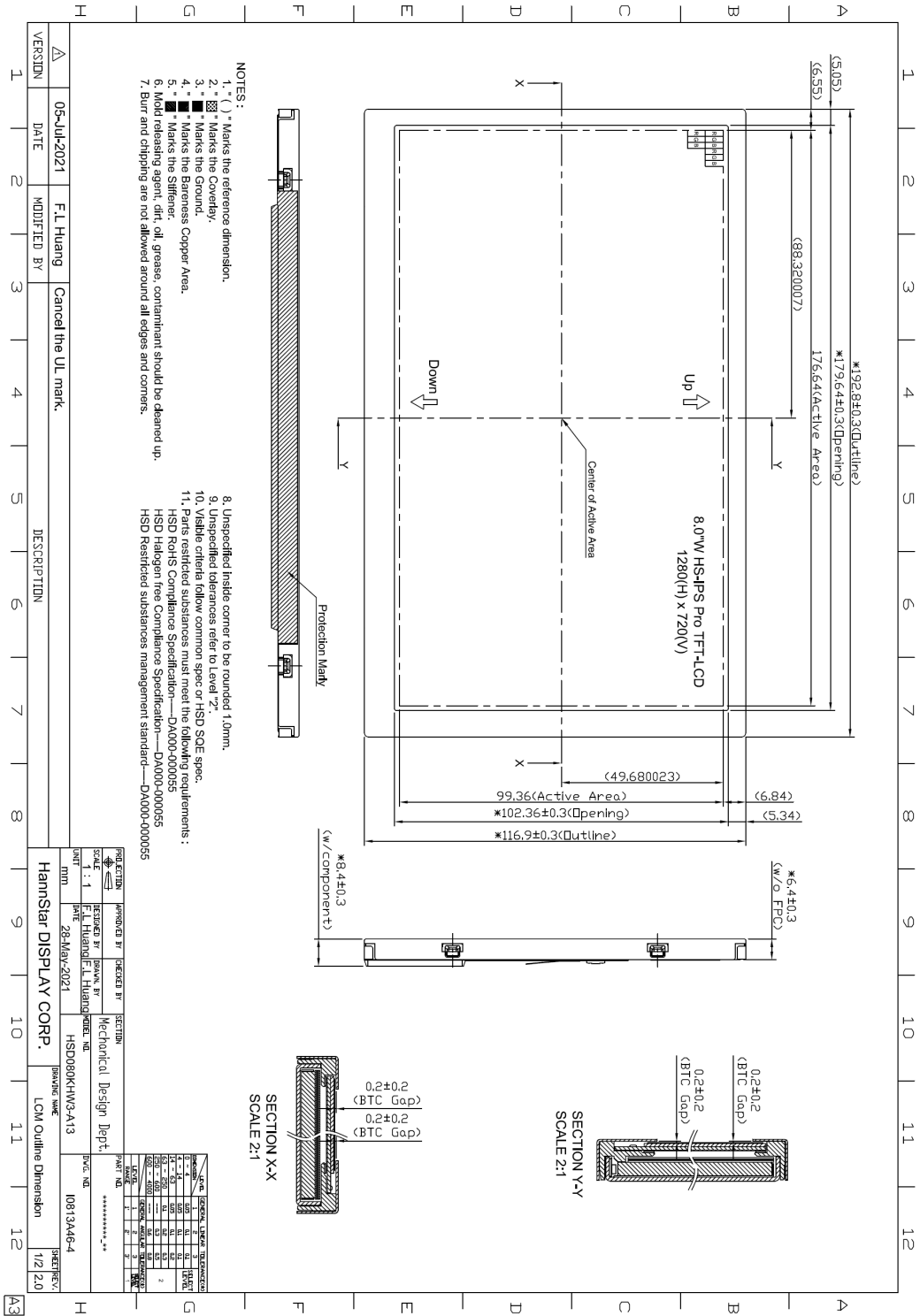

Document Title	HSD080JHW3-A13 Product Information for DATA MODUL	Page No.	22 / 26
Document No.		Revision	1.0

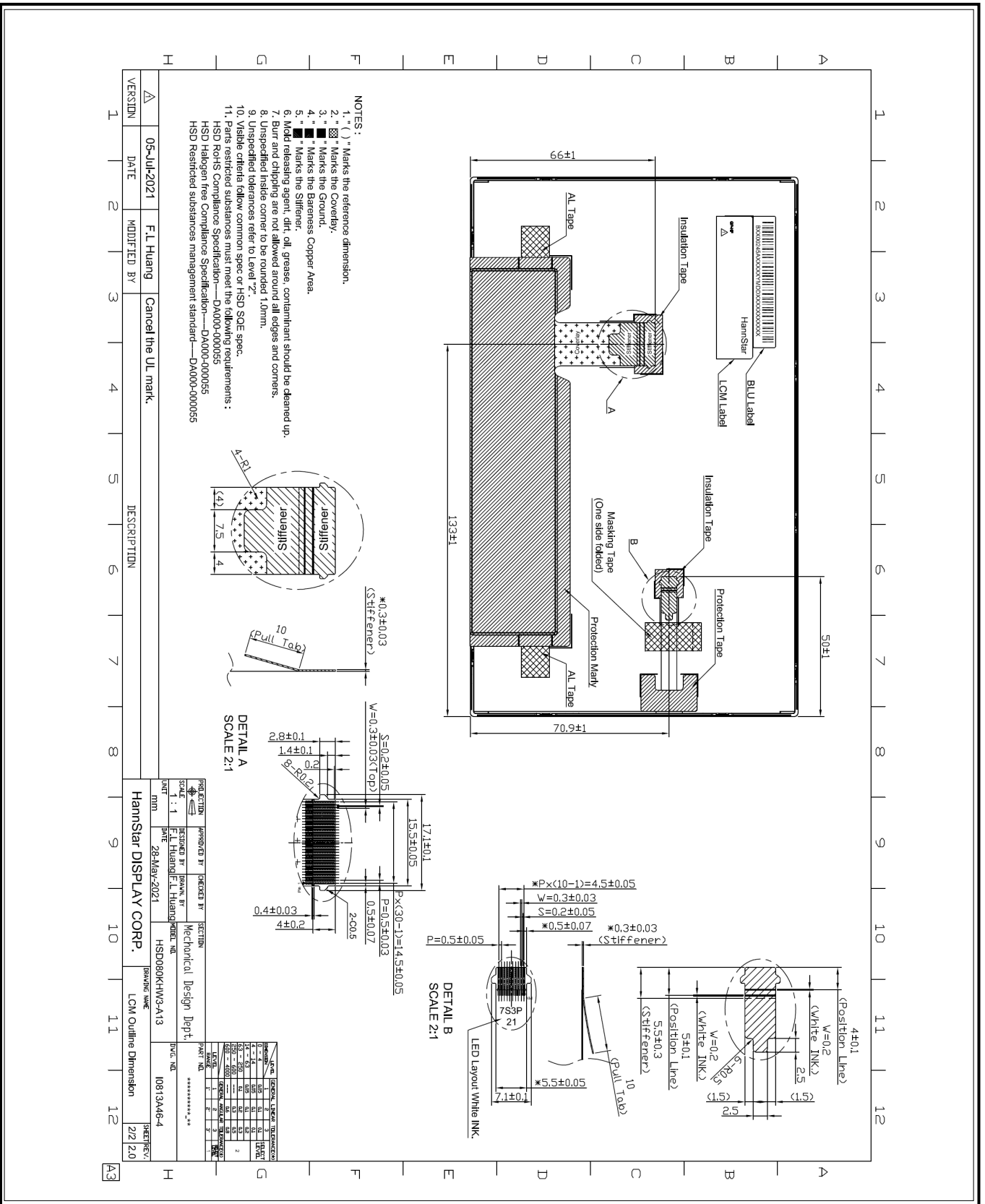

Document Title	HSD080JHW3-A13 Product Information for DATA MODUL	Page No.	23 / 26
Document No.		Revision	1.0

9.0 LOT MARK

9.1 Lot Mark

1	2	3	4	5	6	7	8	9	10	11	12	13	14	15
---	---	---	---	---	---	---	---	---	----	----	----	----	----	----

Code 1,2,3,4,5,6: HannStar internal flow control code.

Code 7: production location.

Code 8: production year.

Code 9: production month.

Code 10,11,12,13,14,15: serial number.

Note (1) Production Year: Code 8 is defined by the last number of the year, for example

Year	2016	2017	2018	2019	2020	2021	2022	2023	2024	2025	2026
Mark	6	7	8	9	0	1	2	3	4	5	6

Note (2) Production Month

Month	Jan.	Feb.	Mar.	Apr.	May.	Jun.	Jul.	Aug.	Sep.	Oct	Nov.	Dec.
Mark	1	2	3	4	5	6	7	8	9	A	B	C

9.2 Detail of Lot Mark

- (1) Below label is attached on the backside of the LCD module. See Section 8.0: Outline Dimension.
- (2) The detail of Lot Mark is attached as below.
- (3) This is subject to change without prior notice.

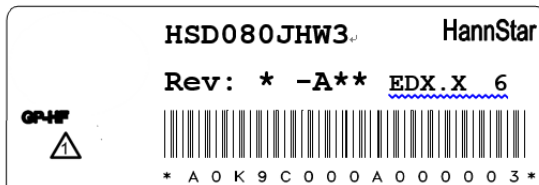

Document Title	HSD080JHW3-A13 Product Information for DATA MODUL	Page No.	24 / 26
Document No.		Revision	1.0

10.0 PACKAGE SPECIFICATION

10.1 Packing form

- (1) Package quantity in one carton : 32 pieces.
- (2) Carton size : 556 mm × 376 mm × 183(H) mm.

10.2 Packing assembly drawings

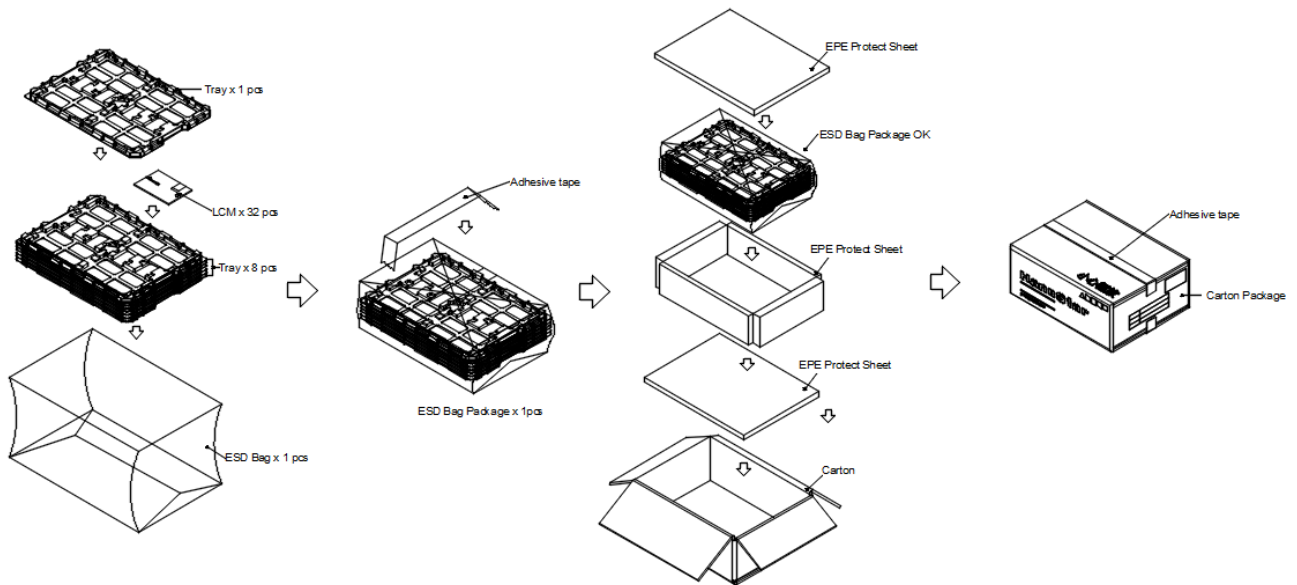

	Material	Notice
Box	Corrugated Paper Board	(AB Flute)
Partition/Pad	PET Tray	
Corner Pad	EPE Sheet	
ESD bag	PE	

Document Title	HSD080JHW3-A13 Product Information for DATA MODUL	Page No.	25 / 26
Document No.		Revision	1.0

11.0 GENERAL PRECAUTION

11.1 Use Restriction

This product is not authorized for use in life supporting systems, aircraft navigation control systems, military systems and any other application where performance failure could be life-threatening or otherwise catastrophic.

11.2 Disassembling or Modification

Do not disassemble or modify the module. It may damage sensitive parts inside LCD module, and may cause scratches or dust on the display. HannStar does not warrant the module, if customers disassemble or modify the module.

11.3 Breakage of LCD Panel

11.3.1. If LCD panel is broken and liquid crystal spills out, do not ingest or inhale liquid crystal, and do not contact liquid crystal with skin.

11.3.2. If liquid crystal contacts mouth or eyes, rinse out with water immediately.

11.3.3. If liquid crystal contacts skin or cloths, wash it off immediately with alcohol and rinse thoroughly with water.

11.3.4. Handle carefully with chips of glass that may cause injury, when the glass is broken.

11.4 Electric Shock

11.4.1. Disconnect power supply before handling LCD module.

11.4.2. Do not pull or fold the LED cable.

11.4.3. Do not touch the parts inside LCD modules and the fluorescent LED's connector or cables in order to prevent electric shock.

11.5 Absolute Maximum Ratings and Power Protection Circuit

11.5.1. Do not exceed the absolute maximum rating values, such as the supply voltage variation, input voltage variation, variation in parts' parameters, environmental temperature, etc., otherwise LCD module may be damaged.

11.5.2. Please do not leave LCD module in the environment of high humidity and high temperature for a long time.

11.5.3. It's recommended to employ protection circuit for power supply.

11.6 Operation

11.6.1 Do not touch, push or rub the polarizer with anything harder than HB pencil lead.

11.6.2 Use fingerstalls of soft gloves in order to keep clean display quality, when persons handle the LCD module for incoming inspection or assembly.

11.6.3 When the surface is dusty, please wipe gently with absorbent cotton or other soft material.

Document Title	HSD080JHW3-A13 Product Information for DATA MODUL	Page No.	26 / 26
Document No.		Revision	1.0

11.6.4 Wipe off saliva or water drops as soon as possible. If saliva or water drops contact with polarizer for a long time, they may causes deformation or color fading.

11.6.5 When cleaning the adhesives, please use absorbent cotton wetted with a little petroleum benzine or other adequate solvent.

11.7 Mechanism

Please mount LCD module by using mounting holes arranged in four corners tightly.

11.8 Static Electricity

11.8.1 Protection film must remove very slowly from the surface of LCD module to prevent from electrostatic occurrence.

11.8.2 Because LCD module use CMOS-IC on circuit board and TFT-LCD panel, it is very weak to electrostatic discharge. Please be careful with electrostatic discharge. Persons who handle the module should be grounded through adequate methods.

11.9 Strong Light Exposure

The module shall not be exposed under strong light such as direct sunlight. Otherwise, display characteristics may be changed.

11.10 Disposal

When disposing LCD module, obey the local environmental regulations.



ALL TECHNOLOGIES. ALL COMPETENCIES. ONE SPECIALIST.



DATA MODUL AG
Landsberger Straße 322
DE-80687 Munich
Phone: +49-89-56017-0

DATA MODUL WEIKERSHEIM GMBH
Lindenstraße 8
DE-97990 Weikersheim
Phone: +49-7934-101-0



More information and worldwide locations can be found at

www.data-modul.com