



# SPECIFICATION

---



**LD750DGN-FRH3**

75" – UHD – V-by-One

Version: 1.0  
Date: 13.02.2023

Note: This specification is subject to change without prior notice

# SPECIFICATION FOR APPROVAL

- ( ) Preliminary Specification  
 (●) Final Specification



Title	75.0" QWUXGA TFT LCD
-------	----------------------

BUYER	Common
MODEL	

SUPPLIER	LG Display Co., Ltd.
*MODEL	LD750DGN
SUFFIX	FRH3 (RoHS Verified)

APPROVED BY	SIGNATURE DATE
/	
/	
/	

Please return 1 copy for your confirmation with your signature and comments.

<b>APPROVED BY</b> Moohyoung Song / Team Leader	<b>SIGNATURE DATE</b>  2023.2.15
<b>REVIEWED BY</b> Hojune Kim / Project Leader	 2023.2.15
<b>PREPARED BY</b> Buyeon Kim / Engineer	 2023.2.15

**TV Product Development Dept.  
LG Display Co., Ltd.**

## Product Specification

**CONTENTS**

Number	ITEM	Page
	COVER	-
	CONTENTS	1
	RECORD OF REVISIONS	2
1	GENERAL DESCRIPTION	3
2	ABSOLUTE MAXIMUM RATINGS	4
3	ELECTRICAL SPECIFICATIONS	5
3-1	ELECTRICAL CHARACTERISTICS	5
3-2	INTERFACE CONNECTIONS	7
3-3	SIGNAL TIMING SPECIFICATIONS	11
3-4	V by One SIGNAL SPECIFICATIONS	12
3-5	COLOR DATA REFERENCE	14
3-6	POWER SEQUENCE	15
4	OPTICAL SPECIFICATIONS	17
5	MECHANICAL CHARACTERISTICS	21
6	RELIABILITY	24
7	INTERNATIONAL STANDARDS	25
7-1	SAFETY	25
7-2	ENVIRONMENT	25
8	PACKING	26
8-1	INFORMATION OF LCM LABEL	26
8-2	PACKING FORM	26
9	PRECAUTIONS	27
9-1	MOUNTING PRECAUTIONS	27
9-2	OPERATING PRECAUTIONS	27
9-3	ELECTROSTATIC DISCHARGE CONTROL	28
9-4	PRECAUTIONS FOR STRONG LIGHT EXPOSURE	28
9-5	STORAGE	28
9-6	APPROPRIATE CONDITION FOR COMMERCIAL DISPLAY	29



## Product Specification

## 1. General Description

The LD750DGN is a Color Active Matrix Liquid Crystal Display with an integral the Source PCB and Gate implanted on Panel (GIP). The matrix employs a-Si Thin Film Transistor as the active element. It is a transmissive type display operating in the normally black mode. It has a 85.60 inch diagonally measured active display area with QWUXGA resolution (2160 vertical by 3840 horizontal pixel array).

Each pixel is divided into Red, Green and Blue sub-pixels or dots which are arranged in vertical stripes. Gray scale or the luminance of the sub-pixel color is determined with a 10-bit gray scale signal for each dot. Therefore, it can present a palette of more than 1.07 billion colors.

It has been designed to apply the 10-bit (D) 16 Lane V by One interface.

It is intended to support LCD TV, PCTV, Commercial Display where high brightness, super wide viewing angle, high color gamut, high color depth and fast response time are important.

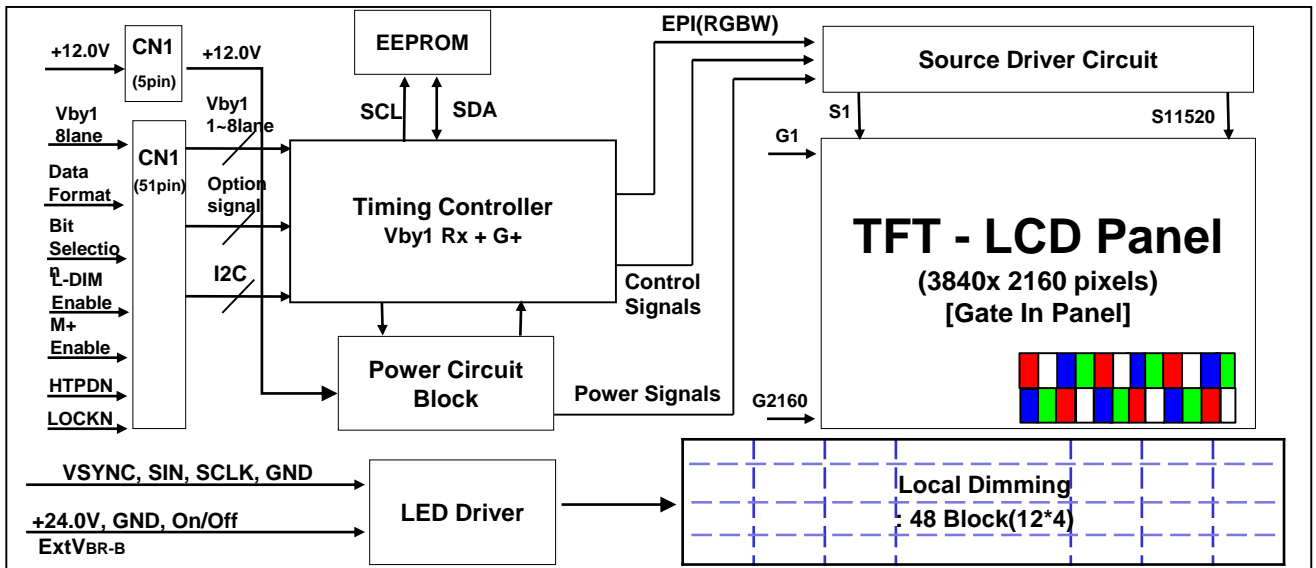

## General Features

Active Screen Size	74.52 inches diagonal
Outline Dimension	1675.2(H) x 953.6(V) x 54.6 (B)(Typ.)
Pixel Pitch	0.429 mm x 0.429 mm
Pixel Format	3840 horiz. by 2160 vert. Pixels,
Display Mode	IPS
Color Depth	10bit(D), 1.07Billion colors
Interface	Vby1 8Lane
Luminance, White	3000cd/m <sup>2</sup> (Center 1point ,Typ.)
BLU Type	Direct type
Viewing Angle (CR>10)	Viewing angle free ( R/L 178 (Min.), U/D 178 (Min.)
Power Consumption	Total 607.0W (Typ.) - Logic= 17.9W (Typ.), 28.2W (Max.) - LED Driver= 589.1W (ExtVbr_B=100%)(Typ.) , 643.5W (Max,)
Weight	26.6 Kg (Typ.), 29.3 Kg(Max)
Display Mode	Transmissive mode, Normally black
Surface Treatment	Hard coating(2H), Anti-glare treatment of the front polarizer (Haze 3%(Typ.))
Possible Display Type	Landscape and Portrait Enabled

## Product Specification

## 2. Absolute Maximum Ratings

The following items are maximum values which, if exceeded, may cause faulty operation or permanent damage to the LCD module.

**Table 1. ABSOLUTE MAXIMUM RATINGS**

Parameter		Symbol	Value		Unit	Note	
			Min	Max			
Power Input Voltage	LCD Circuit	VLCD	-0.3	+14.0	VDC	1	
	Driver	VBL	-0.3	+ 27.0	VDC		
Driver Control Voltage	ON/OFF	V <sub>OFF</sub> / V <sub>ON</sub>	-0.3	+3.9	VDC		
	Brightness	EXTVBR-B	-0.3	+3.9	VDC		
	Status	Status	-0.3	+3.9	VDC		
T-Con Option Selection Voltage		V <sub>LOGIC</sub>	-0.3	+4.0	VDC		
Operating Temperature		T <sub>OP</sub>	0	+50	°C		2,3
Storage Temperature		T <sub>ST</sub>	-20	+60	°C		
Panel Front Temperature (Considering L/C Phase Transition Temperature)		T <sub>SUR</sub>	-	+68	°C		4
Operating Ambient Humidity		H <sub>OP</sub>	10	90	%RH		2,3
Storage Humidity		H <sub>ST</sub>	5	90	%RH		

Note 1. Ambient temperature condition ( $T_a = 25 \pm 2 \text{ }^\circ\text{C}$ )

2. Temperature and relative humidity range are shown in the figure below.

Wet bulb temperature should be Max 39°C, and no condensation of water.

3. Gravity mura can be guaranteed below 50°C condition.

4. The maximum operating temperatures is based on the test condition that the surface temperature of display area is less than or equal to 68°C with LCD module alone in a temperature controlled chamber. Thermal management should be considered in final product design to prevent the surface temperature of display area from being over 68°C. The range of operating temperature may be degraded in case of improper thermal management in final product design.

5. Prevent products from being exposed to the direct sunlight. Otherwise, its reliability and function may not be guaranteed

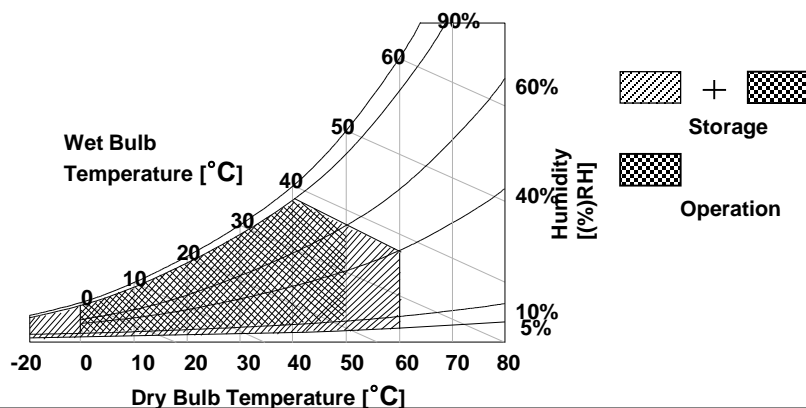

## Product Specification

### 3. Electrical Specifications

#### 3-1. Electrical Characteristics

It requires two power inputs. One is employed to power for the LCD circuit. The other is used for the LED backlight and LED Driver circuit.

**Table 2. ELECTRICAL CHARACTERISTICS**

Parameter	Symbol	Value			Unit	Note	
		Min	Typ	Max			
<b>Circuit :</b>							
Power Input Voltage	V <sub>LCD</sub>	10.8	12.0	13.2	V <sub>DC</sub>		
Power Input Current	I <sub>LCD</sub>	-	1490	1937	mA	1	
		-	2350	3055	mA	2	
T-CON Option Selection Voltage	Input High Voltage	V <sub>IH</sub>	2.7	-	3.6	V <sub>DC</sub>	
	Input Low Voltage	V <sub>IL</sub>	0	-	0.7	V <sub>DC</sub>	
Power Consumption	P <sub>LCD</sub>	-	17.9	23.3	Watt	1	
			28.2	36.7		2	
Rush current	I <sub>RUSH</sub>	-	-	10.0	A	3	

- note 1. The specified current and power consumption are under the  $V_{LCD}=12.0V$ ,  $T_a=25 \pm 2^\circ C$ ,  $f_v=60Hz$  condition, and mosaic pattern(8 x 6) is displayed and  $f_v$  is the frame frequency.  
 2. The current and power consumption are specified at the maximum current pattern.  
 3. The duration of rush current is about 2ms and rising time of power input is 0.5ms (min.).  
 4. Ripple voltage level is recommended under  $\pm 5\%$  of typical voltage

White : 255 Gray  
 Black : 0 Gray

Full White  
 R : 1023 Gray, G : 1023 Gray, B : 1023 Gray

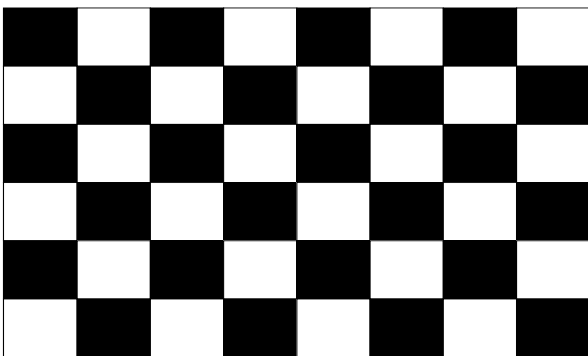

**Mosaic Pattern(8 x 6)**



**Max Current Pattern**

## Product Specification

Table 3. ELECTRICAL CHARACTERISTICS (Continue)

Parameter		Symbol	Values			Unit	Notes		
			Min	Typ	Max				
LED Driver :									
Power Supply Input Voltage		VBL	21.6	24.0	26.4	Vdc	1		
Power Supply Input Current		IBL	-	24.5	26.8	A	1		
Power Supply Input Current (In-Rush)		In-rush	-	-	35.8	A	VBL = 21.6V ExtVBR-B=100% 3		
Power Consumption (Total)		PBL	-	589.1	643.5	W	1		
Input Voltage for Control System Signals	On/Off	On	V on	2.5	-	3.6	Vdc	On Duty 5	
		Off	V off	-0.3	0.0	0.7	Vdc		
	Brightness Adjust		ExtVBR-B	1	-	100	%		
	PWM Frequency for NTSC & PAL		PAL		100		Hz		2
			NTSC		120		Hz		2
	Pulse Duty Level (PWM)		HighLevel	2.5	-	3.6	Vdc		HIGH : on duty LOW : off duty
Low Level			0.0	-	0.7	Vdc			
LED :									
Life Time			50,000	-	-	Hrs	6		

## Notes :

- Electrical characteristics are determined after the unit has been 'ON' and stable for approximately 60 minutes at  $25 \pm 2^\circ\text{C}$ . The specified temperature, optical, and power consumption are under the typical supply Input voltage 24V, current & VBR (ExtVBR-B : 100%), it is total power consumption.
- LGD recommend that the PWM freq. is synchronized with Two time harmonic of V\_sync signal of system. Though PWM frequency is over 120Hz (max 252Hz), function of LED Driver is not affected.
- The duration of rush current is about 200ms. This duration is applied to LED on time
- Even though inrush current is over the specified value, there is no problem if I<sup>2</sup>T spec of fuse is satisfied.
- Ext\_PWM Signal have to input available duty range.  
Between 99% and 100% ExtVBR-B duty have to be avoided. ( $99\% < \text{ExtVBR-B} < 100\%$ )  
But ExtVBR-B 0% and 100% is possible.
- The life time(L50B10) is defined as the time which luminance of the LED is 50% compared to its original value.  
※ Operating condition :  $T_a = 25 \pm 2^\circ\text{C}$ , for LED only

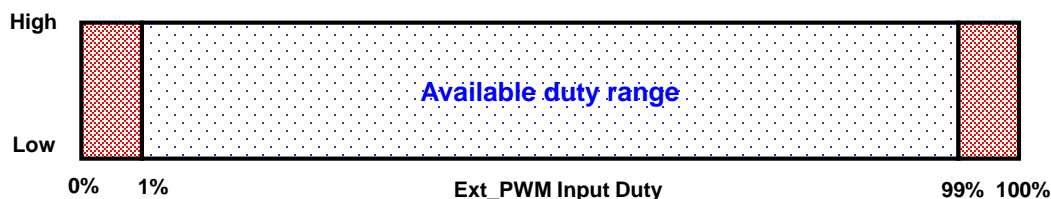



## Product Specification

**3-2. Interface Connections**

This LCD module employs three kinds of interface connection, 5-pin connector and 51-pin connector are used for the module electronics and 14-pin,12-pin connector is used for the integral backlight system.

**3-2-1. LCD Module**

- LCD Connector(CN1): 20037WR-H05 (manufactured by YEONHO)

**Table 4-1. MODULE CONNECTOR(CN1) PIN CONFIGURATION**

Pin No	Symbol	Description	Note
1	GND	Ground	
2	GND	Ground	
3	VLCD	Power Supply +12.0V	
4	VLCD	Power Supply +12.0V	
5	VLCD	Power Supply +12.0V	

## Product Specification

- LCD Connector(CN2): 05030WR-H51B(NC) (manufactured by YEONHO)

**Table 4-2. MODULE CONNECTOR(CN2) PIN CONFIGURATION**

No	Symbol	Description	No	Symbol	Description
1	NC	No Connection(Notes 2)	27	GND	Ground
2	NC	No Connection(Notes 2)	28	Rx0n	V-by-One HS Data Lane 0
3	NC	No Connection(Notes 2)	29	Rx0p	V-by-One HS Data Lane 0
4	NC	No Connection(Notes 2)	30	GND	Ground
5	NC	No Connection(Notes 2)	31	Rx1n	V-by-One HS Data Lane 1
6	NC	No Connection(Notes 2)	32	Rx1p	V-by-One HS Data Lane 1
7	NC	No Connection(Notes 2)	33	GND	Ground
8	NC	No Connection(Notes 2)	34	Rx2n	V-by-One HS Data Lane 2
9	NC	No Connection	35	Rx2p	V-by-One HS Data Lane 2
10	GND	Ground	36	GND	Ground
11	GND	Ground	37	Rx3n	V-by-One HS Data Lane 3
12	GND	Ground	38	Rx3p	V-by-One HS Data Lane 3
13	GND	Ground	39	GND	Ground
14	NC	NO CONNECTION	40	Rx4n	V-by-One HS Data Lane 4
15	Input Mode	Vx1 Input Data Format 'L'=Non-Division , 'H'=2-Division	41	Rx4p	V-by-One HS Data Lane 4
16	NC	No Connection	42	GND	Ground
17	NC	No Connection	43	Rx5n	V-by-One HS Data Lane 5
18	NC	No Connection	44	Rx5p	V-by-One HS Data Lane 5
19	NC	No Connection	45	GND	Ground
20	NC	No Connection	46	Rx6n	V-by-One HS Data Lane 6
21	Bit_SEL	'H' = 10bit , 'L' = 8bit	47	Rx6p	V-by-One HS Data Lane 6
22	LOCAL_ON	H' = Enable	48	GND	Ground
23	M+ Bypass	'H' = RGB, 'L' = M+	49	Rx7n	V-by-One HS Data Lane 7
24	GND	Ground	50	Rx7p	V-by-One HS Data Lane 7
25	HTPDN	Hot plug detect	51	GND	Ground
26	LOCKN	Lock detect	-	-	-

- notes
1. All GND (ground) pins should be connected together to the LCD module's metal frame.
  2. #1~#8 NC (No connection) : These pins are used for back up power source, V<sub>LCD</sub> (power input). These pins should be connected together.
  3. All Input levels of V-by-One signals are based on the V-by-One HS Standard Version 1.4.
  4. #9 & #14 & #16 ~#20 NC(No Connection) : These pins are used only for LGD (Do not connect)
  5. Specific pin (#22) is used for Local Dimming function of the LCD module.  
If not used, these pins are no connection. (Please see the Appendix IV-2 for more information.)
  6. About specific pin (#15), Please see the Appendix VI.

Product Specification

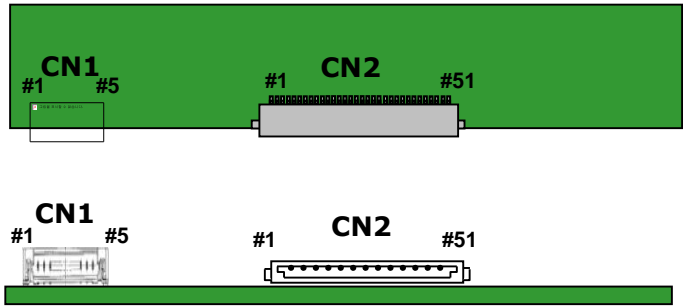

Rear view of LCM

## Product Specification

## 3-2-2. Backlight Module

Master

-LED Driver Connector

: 20022WR - H14B2(Yeonho), 20022WR-H12B2(Yeonho) or Compatible

- Mating Connector

: 20022HS-H14B2(Yeonho) , 20022HS-H12B2(Yeonho) or Compatible

Table 5-1. LED DRIVER CONNECTOR PIN CONFIGURATION

Pin No	Symbol	Description (CN101)	Description (CN102)	Note
1	VBL	Power Supply +24.0V	Power Supply +24.0V	
2	VBL	Power Supply +24.0V	Power Supply +24.0V	
3	VBL	Power Supply +24.0V	Power Supply +24.0V	
4	VBL	Power Supply +24.0V	Power Supply +24.0V	
5	VBL	Power Supply +24.0V	Power Supply +24.0V	
6	GND	Backlight Ground	Backlight Ground	1
7	GND	Backlight Ground	Backlight Ground	
8	GND	Backlight Ground	Backlight Ground	
9	GND	Backlight Ground	Backlight Ground	
10	GND	Backlight Ground	Backlight Ground	
11	Status	Backlight Status	No Connection	2
12	VON/OFF	Backlight ON/OFF control	No Connection	
13	NC	No Connection		
14	EXTVBR_B	External PWM		3

notes : 1. GND should be connected to the LCD module's metal frame.

2. Normal : Low (under 0.7V) / Abnormal : Open

3. High : on duty / Low : off duty, Pin#14 can be opened. ( if Pin #14 is open , EXTVBR-B is 100% )

4. Each impedance of pin #12 and 14 is over 50 [KΩ] .

## ◆ Rear view of LCM

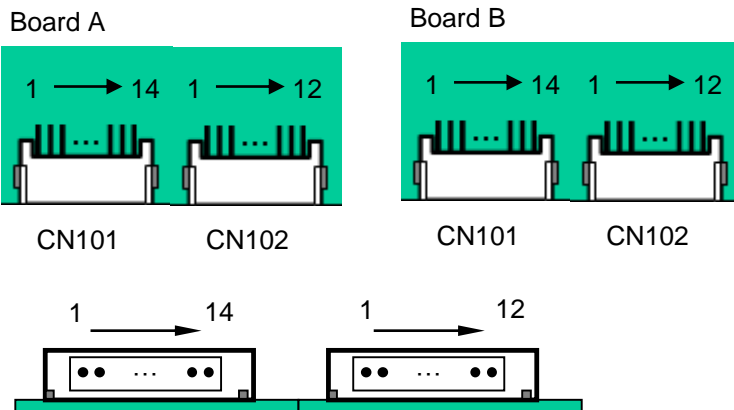

## ◆ Status

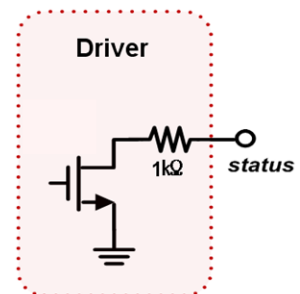

## Product Specification

**3-3. Signal Timing Specifications**

Table 6 shows the signal timing required at the input of the LVDS transmitter. All of the interface signal timings should be satisfied with the following specification for normal operation.

Table 6. TIMING TABLE (DE Only Mode)

ITEM		Symbol	Min	Typ	Max	Unit	Note
Horizontal	Display Period	$t_{HV}$	480	480	480	$t_{CLK}$	3840/8
	Blank	$t_{HB}$	60	70	120	$t_{CLK}$	1
	Total	$t_{HP}$	540	550	600	$t_{CLK}$	
Vertical	Display Period	$t_{VV}$	2160	2160	2160	Lines	
	Blank	$t_{VB}$	40	90	600	Lines	1
	Total	$t_{VP}$	2200	2250	2760	Lines	

ITEM		Symbol	Min	Typ	Max	Unit	Note
Frequency	DCLK	$f_{CLK}$	67	74.25	78.00	MHz	594/8
	Horizontal	$f_H$	121.8	135	140	KHz	2
	Vertical	$f_V$	47	60	63	Hz	2

notes: 1. The input of HSYNC & VSYNC signal does not have an effect on normal operation (DE Only Mode).  
If you use spread spectrum of EMI, add some additional clock to minimum value for clock margin.

2. The performance of the electro-optical characteristics may be influenced by variance of the vertical refresh rate and the horizontal frequency

3. Spread Spectrum Rate (SSR) is limited to  $\pm 0.5\%$  center spread at 30KHz

※ Timing should be set based on clock frequency.

## Product Specification

## 3-4. V by One Signal Specifications

## 3-4-1. V by One Input Signal Timing Diagram

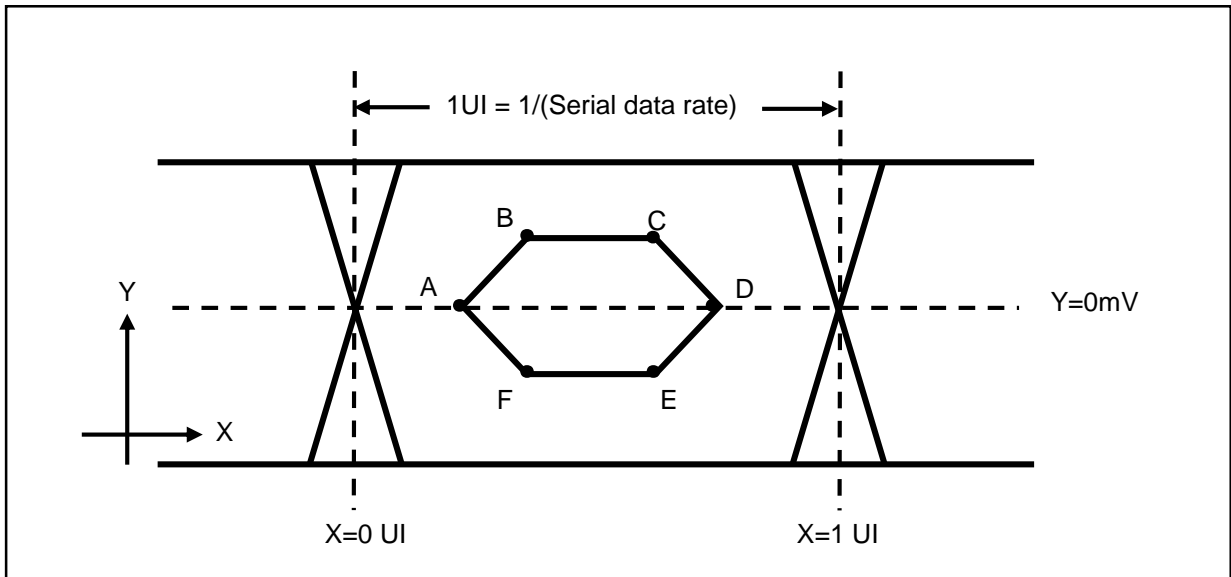

Table7. Eye Mask Specification

	X[UI]	Note	Y[mV]	Note
A	0.25 (max)	2	0	-
B	0.3 (max)	2	50	3
C	0.7(min)	3	50	3
D	0.75(min)	3	0	-
E	0.7(min)	3	-50	3
F	0.3(max)	2	-50	3

notes 1. All Input levels of V by One signals are based on the V by One HS Standard Ver. 1.4

2. This is allowable maximum value.

3. This is allowable minimum value.

4. The eye diagram is measured by the oscilloscope and receiver CDR characteristic must be emulated.

- PLL bandwidth : 15 Mhz

- Damping Factor : 1.0

## Product Specification

## 3-4-2. V by One Input Signal Characteristics

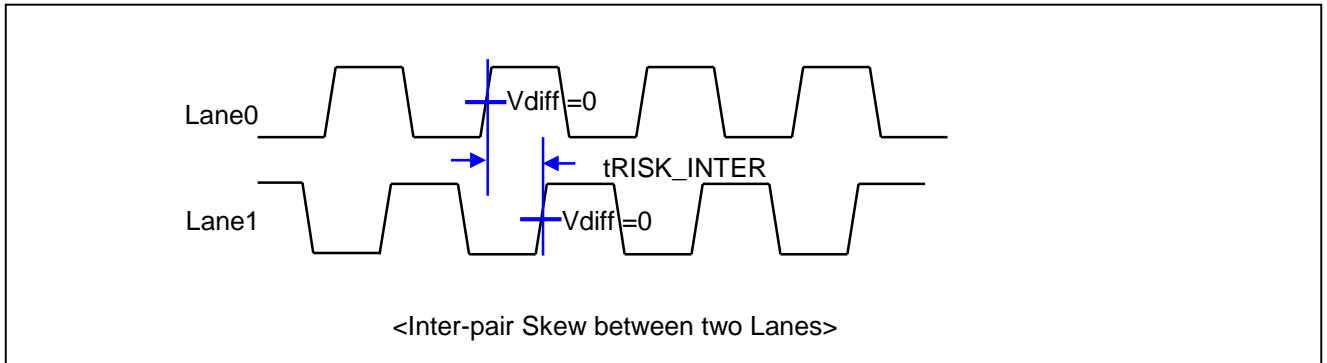

Description	Symbol	Min	Max	Unit	notes
Allowable inter-pair skew between lanes	$t_{RISK\_INTER}$	-	5	UI	1,2

Notes 1.  $1UI = 1/\text{serial data rate}$

2. it is the time difference of the differential voltage between any two lanes in one sub block.

## Product Specification

### 3-5. Color Data Reference

The brightness of each primary color (red, green, blue) is based on the 10bit or 8bit gray scale data input for the color.

The higher binary input, the brighter the color. Table 8 provides a reference for color versus data input.

**Table 8. COLOR DATA REFERENCE**

Packer input & Unpacker output		30bpp RGB (10bit)	24bpp RGB (8bit)
Byte0	D[0]	R[2]	R[0]
	D[1]	R[3]	R[1]
	D[2]	R[4]	R[2]
	D[3]	R[5]	R[3]
	D[4]	R[6]	R[4]
	D[5]	R[7]	R[5]
	D[6]	R[8]	R[6]
Byte1	D[7]	R[9]	R[7]
	D[8]	G[2]	G[0]
	D[9]	G[3]	G[1]
	D[10]	G[4]	G[2]
	D[11]	G[5]	G[3]
	D[12]	G[6]	G[4]
	D[13]	G[7]	G[5]
Byte2	D[14]	G[8]	G[6]
	D[15]	G[9]	G[7]
	D[16]	B[2]	B[0]
	D[17]	B[3]	B[1]
	D[18]	B[4]	B[2]
	D[19]	B[5]	B[3]
	D[20]	B[6]	B[4]
Byte4	D[21]	B[7]	B[5]
	D[22]	B[8]	B[6]
	D[23]	B[9]	B[7]
	D[24]	Don't care	
	D[25]	Don't care	
	D[26]	B[0]	
	D[27]	B[1]	
Byte4	D[28]	G[0]	
	D[29]	G[1]	
	D[30]	R[0]	
	D[31]	R[1]	



## Product Specification

## 3-6. Power Sequence

## 3-6-1. LCD Driving circuit

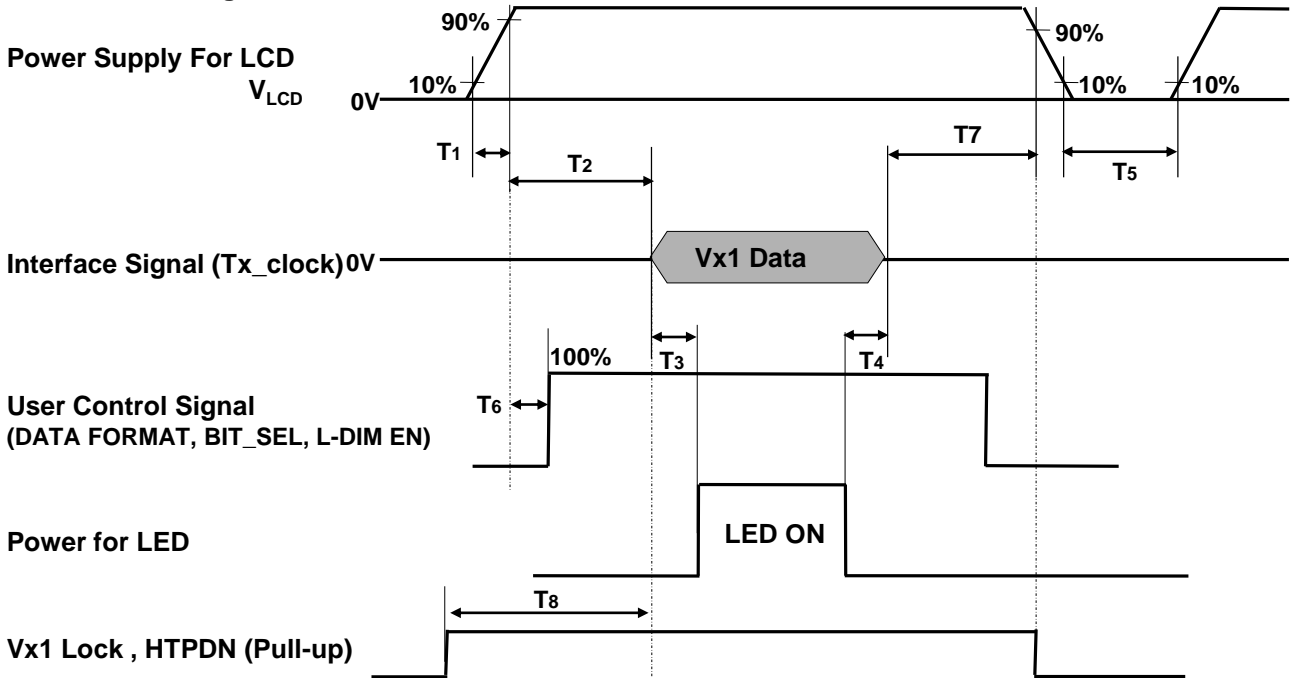

Table 9. POWER SEQUENCE

Parameter	Value			Unit	Note
	Min	Typ	Max		
T1	0.5	-	20	ms	1
T2	0	-	-	ms	2
T3	400	-	-	ms	3
T4	100	-	-	ms	3
T5	3.0	-	-	s	4
T6	0	-	T2	ms	5
T7	0	-	-	ms	6
T8	0	-	-	ms	

- Note :
1. Even though T1 is over the specified value, there is no problem if I2T spec of fuse is satisfied.
  2. If T2 is satisfied with specification after removing LVDS Cable, there is no problem.
  3. The T3 / T4 is recommended value, the case when failed to meet a minimum specification, abnormal display would be shown. There is no reliability problem.
  4. T5 should be measured after the Module has been fully discharged between power off and on period.
  5. If the on time of signals (Interface signal and user control signals) precedes the on time of Power ( $V_{LCD}$ ), it will be happened abnormal display. When T6 is NC status, T6 doesn't need to be measured.
  6. It is recommendation specification that T7 has to be 0ms as a minimum value.
- ※ Please avoid floating state of interface signal at invalid period.  
 ※ When the power supply for LCD (VLCD) is off, be sure to pull down the valid and invalid data to 0V.

## Product Specification

## 3-6-2. Sequence for LED Driver

## Power Supply For LED Driver

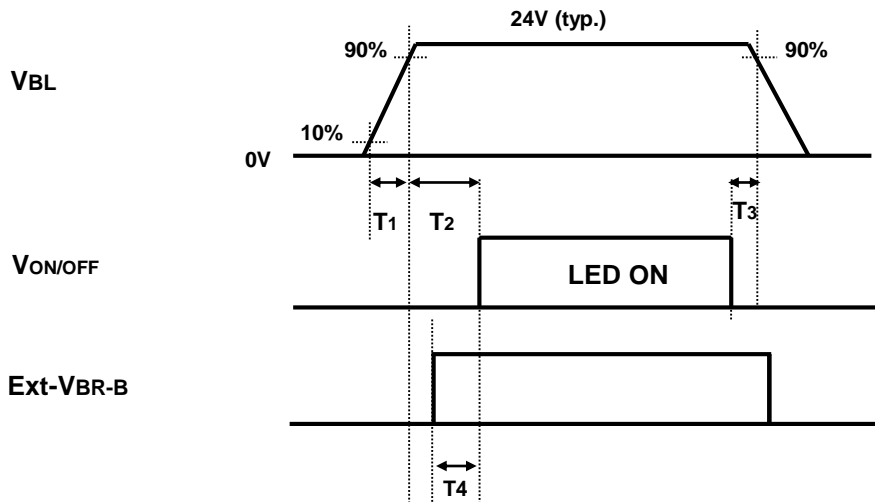

## 3-6-2. Dip condition for LED Driver

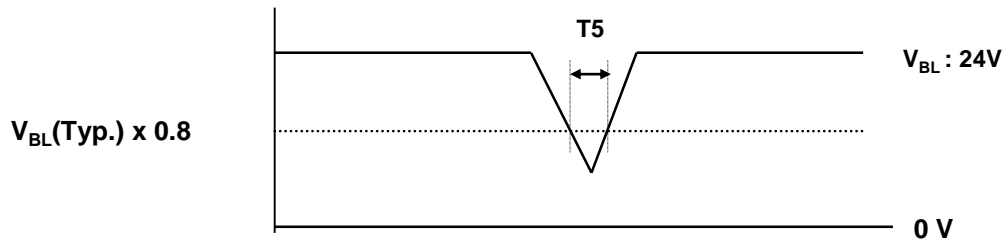

Table 10. Power Sequence for LED Driver

Parameter	Values			Units	Note
	Min	Typ	Max		
T1	20	-	-	ms	1
T2	500	-	-	ms	
T3	10		-	ms	
T4	0	-	-	ms	
T5	-	-	10	ms	$V_{BL(Typ.)} \times 0.8$

## Note

- T1 describes rising time of 0V to 24V and this parameter does not applied at restarting time. Even though T1 is over the specified value, there is no problem if I<sup>2</sup>T spec of fuse is satisfied.

## Product Specification

## 4. Optical Specification

Optical characteristics are determined after the unit has been 'ON' and stable in a dark environment at  $25\pm 2^{\circ}\text{C}$ . The values are specified at 50cm from the LCD surface at a viewing angle of  $\Phi$  and  $\theta$  equal to  $0^{\circ}$ . FIG. 1 shows additional information concerning the measurement equipment and method.

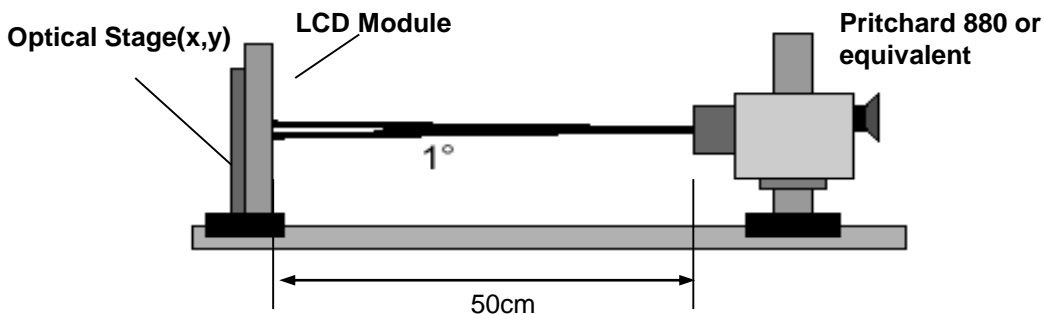

FIG. 1 Optical Characteristic Measurement Equipment and Method

$T_a = 25\pm 2^{\circ}\text{C}$ ,  $V_{\text{LCD}} = 12.0\text{V}$ ,  $f_v = 60\text{Hz}$ ,  $D_{\text{clk}} = 74.25\text{MHz}$ ,  
EXTVBR-B = 100%

Table 11. OPTICAL CHARACTERISTICS

Parameter	Symbol	Value			Unit	notes	
		Min	Typ	Max			
Contrast Ratio	CR	900	1200	-		1	
Surface Luminance, white	$L_{\text{WH}}$	2400	3000	-	$\text{cd/m}^2$	2	
Luminance Variation	$\delta_{\text{WHITE}}$	80	-	-	%	3	
Response Time	Gray-to-Gray	G to G	8	12	ms	4	
	Uniformity	$\delta_{\text{G TO G}}$	-	-	1		5
Color Coordinates [CIE1931]	RED	Rx	Typ -0.03	0.651	Typ +0.03	2	
		Ry		0.330			
	GREEN	Gx		0.301			
		Gy		0.626			
	BLUE	Bx		0.153			
		By		0.056			
	WHITE	Wx		0.279			
	Wy	0.292					
Color Temperature			10,000		K		
Color Gamut(NTSC)			68		%		
Viewing Angle (CR>10)							
	x axis, right( $\phi=0^{\circ}$ )	$\theta_r$ (x axis)	89	-	-	degree	5
	x axis, left ( $\phi=180^{\circ}$ )	$\theta_l$ (x axis)	89	-	-		
	y axis, up ( $\phi=90^{\circ}$ )	$\theta_u$ (y axis)	89	-	-		
	y axis, down ( $\phi=270^{\circ}$ )	$\theta_d$ (y axis)	89	-	-		
Gray Scale			-	-		6	

## Product Specification

notes : 1. Contrast Ratio(CR) is defined mathematically as :

$$\text{Contrast Ratio} = \frac{\text{Surface Luminance with all white pixels}}{\text{Surface Luminance with all black pixels}}$$

It is measured at center 1-point.

2. Optical Characteristics is determined after the unit has been 'ON' and 1 Hour after lighting the backlight in a dark environment at  $25 \pm 2^{\circ}\text{C}$ . Surface luminance is the luminance value at center 1-point across the LCD surface 50cm from the surface with all pixels displaying white.  
 ※L : Low Power Mode, H : High Luminance Mode
3. The variation in surface luminance, WHITE is defined as :  
 $\text{WHITE}(9\text{P}) = \text{Minimum}(\text{Lon}1, \text{Lon}2 \sim \text{Lon}8, \text{Lon}9) / \text{Maximum}(\text{Lon}1, \text{Lon}2 \sim \text{Lon}8, \text{Lon}9) * 100$   
 Where Lon1 to Lon9 are the luminance with all pixels displaying white at 9 locations  
 For more information, see the FIG. 2.
4. Response time is the time required for the display to transit from G(N) to G(M) (Rise Time,  $\text{Tr}_R$ ) and from G(M) to G(N) (Decay Time,  $\text{Tr}_D$ ). For additional information see the FIG. 3. (N<M)  
 ※ G to G Spec stands for average value of all measured points.  
 Photo Detector : RD-80S / Field :  $2^{\circ}$   
 ※. Gray to Gray Response time uniformity is Reference data. Appendix V
5. Viewing angle is the angle at which the contrast ratio is greater than 10. The angles are determined for the horizontal or x axis and the vertical or y axis with respect to the z axis which is normal to the LCD module surface. For more information, see the FIG. 4.
6. Gray scale specification  
 Gamma Value is approximately 2.2. For more information, see the Table 12.

Table 12. GRAY SCALE SPECIFICATION

Gray Level	Luminance [%] (Typ)
L0	0.083
L63	0.27
L127	1.04
L191	2.49
L255	4.68
L319	7.66
L383	11.5
L447	16.1
L511	21.6
L575	28.1
L639	35.4
L703	43.7
L767	53.0
L831	63.2
L895	74.5
L959	86.7
L1023	100

## Product Specification

Measuring point for surface luminance & measuring point for luminance variation.

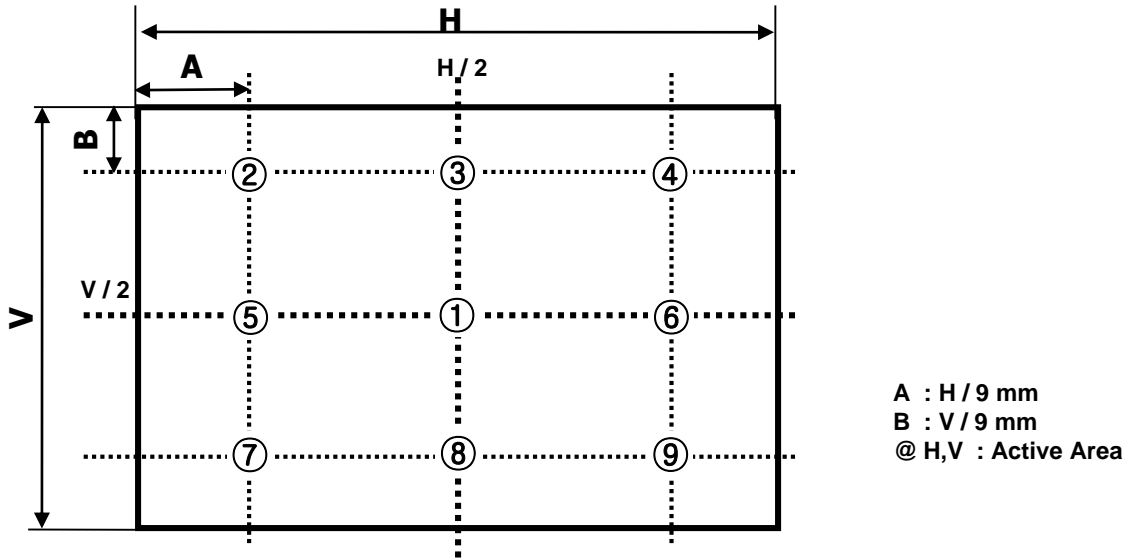

FIG. 2 9 Points for Luminance Measure

Response time is defined as the following figure and shall be measured by switching the input signal for “Gray(N)” and “Gray(M)”.

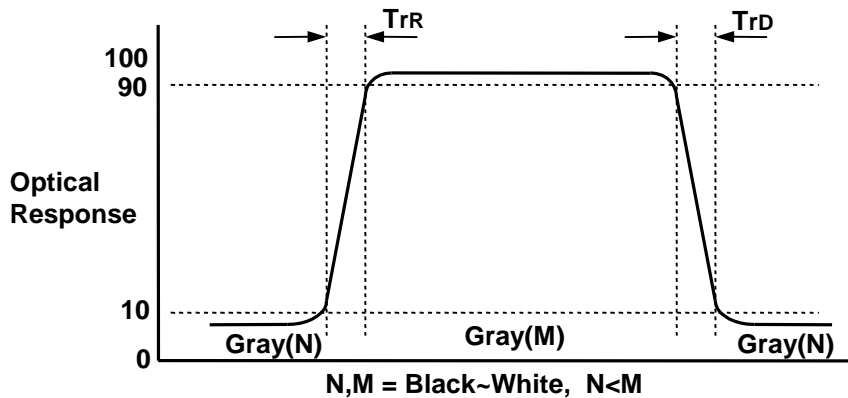
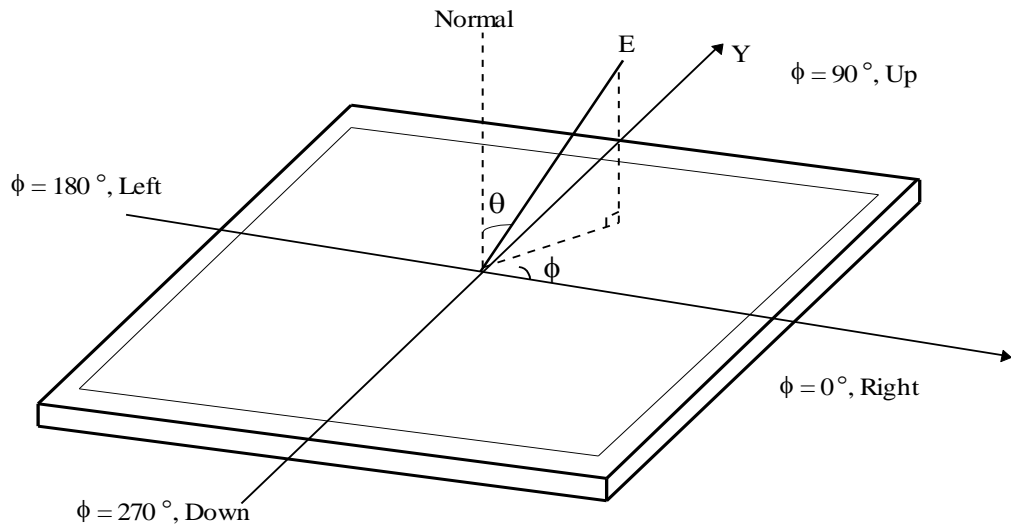

FIG. 3 Response Time

**Dimension of viewing angle range****FIG. 4 Viewing Angle**

## Product Specification

## 5. Mechanical Characteristics

Table 13 provides general mechanical characteristics.

**Table 13. MECHANICAL CHARACTERISTICS**

Item	Value	
Outline Dimension	Horizontal	1675.2mm
	Vertical	953.6 mm
	Depth	54.6 mm
Bezel Area	Horizontal	1651.6 mm
	Vertical	930.0 mm
Active Display Area	Horizontal	1649.664mm
	Vertical	927.936mm
Weight	26.6 Kg (Typ.), 29.3 Kg(Max)	

**notes : Please refer to a mechanical drawing in terms of tolerance at the next page.**

Product Specification

[ FRONT VIEW ]

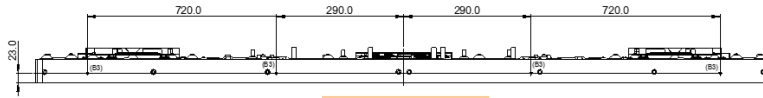

SET : TOP

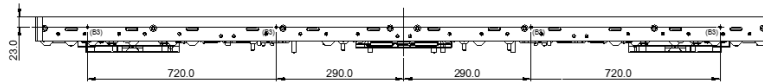
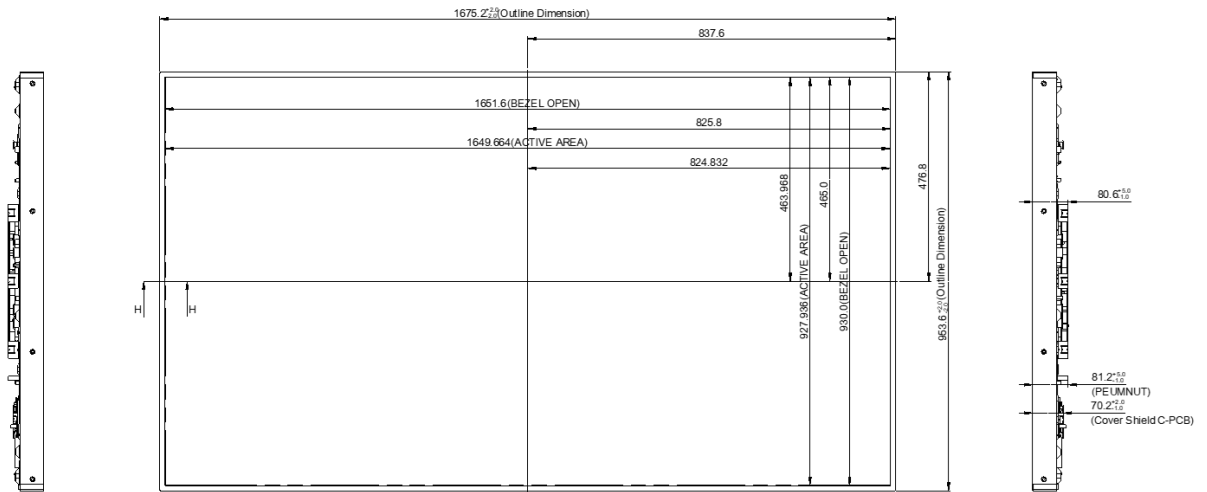

SET : DOWN

- NOTES
1. UNSPECIFIED TOLERANCE IS ± 1.0MM
  2. TLT AND PARTIAL DISPOSITION TOLERANCE OF DISPLAY AREA AS FOLLOWING.
    - (1) Y-DIRECTION |A-B| < 1.5
    - (2) X-DIRECTION |C-D| < 1.5
  3. M3.0 TAP: Max Torque 5kgf.cm
  4. M4.0 TAP: Max Torque 10kgf.cm

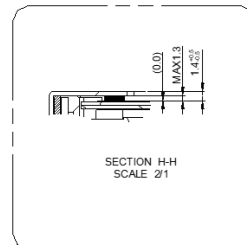
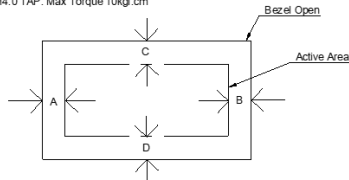

Date	Version
2022.09.21	0.1



Product Specification

[ REAR VIEW ]

SET : TOP

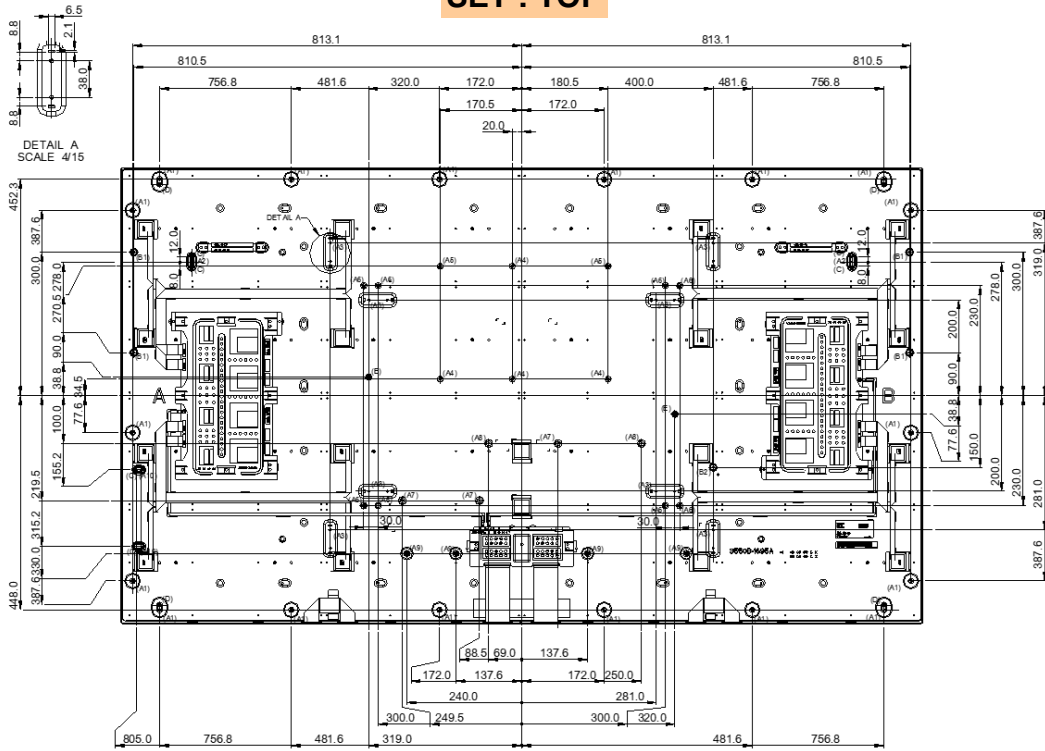

SET : DOWN

ITEM NO.	DESCRIPTION	TYPE	UDM Height (mm)	Max Depth (mm)	Torque (kgf.cm)
(A1)	M3	TAP	10.6	10.6	MAX 5.0
(A2)	M3	TAP	4.0	4.0	MAX 5.0
(A3)	M4	TAP	5.0	5.0	MAX 10.0
(A4)	M3	TAP	8.8	8.8	MAX 5.0
(A5)	M3	TAP	8.8	8.8	MAX 5.0
(A6)	M3	TAP	10.0	10.0	MAX 5.0
(A7)	M3	TAP	26.6	8.0	MAX 5.0
(A8)	M3	TAP	26.6	8.0	MAX 5.0
(A9)	M3	TAP	21.0	8.0	MAX 5.0
(A10)	M3	TAP	3.8	3.8	MAX 5.0
(B1)	M4	TAP	10.6	6.0	MAX 10.0
(B2)	M4	TAP	10.1	5.0	MAX 10.0
(B3)	M4	TAP	0.0	5.0	MAX 10.0
(C)	n 2.2	EMBO	Height 2.0mm		
(A5)	n 3.8	GUIDE PEMNUT	1st Height 8.8mm 2nd Height 4.2mm		
(A8)	n 3.6	GUIDE PEMNUT	1st Height 26.0mm 2nd Height 1.0mm		
(D)	n 5.0	EMBO	Height 2.0mm		
(E)	n 5.0	GUIDE PEMNUT	1st Height 10.0mm 2nd Height 2.0mm		

## Product Specification

**6. Reliability****Table 14. ENVIRONMENT TEST CONDITION**

No.	Test Item	Condition
1	High temperature storage test	Ta= 60°C 90% 240h
2	Low temperature storage test	Ta= -20°C 240h
3	High temperature operation test	Ta= 50°C 50%RH 500h
4	Low temperature operation test	Ta= 0°C 500h
5	Humidity condition Operation	Ta= 40 °C ,90%RH
6	Altitude operating storage / shipment	0 - 16,400 ft 0 - 40,000 ft

- Note : 1. Before and after Reliability test, LCM should be operated with normal function.  
 2. Guarantee Panel Stamp Mura less than 6kgf (Test method : LGD Test method)

## 7. International Standards

### 7-1. Safety

- a) IEC 62368-1, The International Electro-technical Commission (IEC)  
Audio/video, Information and Communication Technology Equipment - Safety - Safety Requirements.
- b) EN IEC 62368-1, European Committee for Electro-technical Standardization (CENELEC)  
Audio/video, Information and Communication Technology Equipment - Safety Requirements
- c) UL 62368-1, Underwriters Laboratories Inc. (UL)  
Audio/video, Information and Communication Technology Equipment - Safety Requirements
- d) CAN/CSA C22.2 No.62368-1, Canadian Standards Association (CSA).  
Audio/video, Information and Communication Technology Equipment - Safety Requirements
- e) IEC 60950-1, The International Electro technical Commission (IEC).  
Information Technology Equipment - Safety - Part 1 : General Requirements

### 7-2. Environment

- a) RoHS, Commission Delegated Directive (EU) 2015/863 of 31 March 2015 amending Annex II to Directive 2011/65/EU of the European Parliament and of the Council

## Product Specification

**8. Packing****8-1. Information of B/Ass'y Label**

## a) Lot Mark

A	B	C	D	E	F	G	H	I	J	K	L	M
---	---	---	---	---	---	---	---	---	---	---	---	---

A,B,C : SIZE(INCH)  
E : MONTH

D : YEAR  
F ~ M : SERIAL NO.

## Note

## 1. YEAR

Year	2020	2021	2022	2023	2024	2025	2026	2027	2028	2029	2030
Mark	K	L	M	N	P	Q	R	S	T	U	V

## 2. MONTH

Month	Jan	Feb	Mar	Apr	May	Jun	Jul	Aug	Sep	Oct	Nov	Dec
Mark	1	2	3	4	5	6	7	8	9	A	B	C

## b) Location of Lot Mark

Serial NO. is printed on the label. The label is attached to the backside of the LCD module.  
This is subject to change without prior notice.

**8-2. Packing Form**

a) Package quantity in one Pallet : 5 pcs

b) Pallet Size : 1910 mm(W) X 760 mm(D) X 1310 mm(H)

## Product Specification

### 9. Precautions

Please pay attention to the followings when you use this TFT LCD module.

#### 9-1. Mounting Precautions

- (1) You must mount a module using specified mounting holes (Details refer to the drawings).
- (2) You should consider the mounting structure so that uneven force (ex. Twisted stress, Concentrated stress) is not applied to the module. And the case on which a module is mounted should have sufficient strength so that external force is not transmitted directly to the module.
- (3) Please attach the surface transparent protective film to the surface in order to protect the polarizer. Transparent protective film should have sufficient strength in order to resist external force.
- (4) You should adopt radiation structure to satisfy the temperature specification.
- (5) Acetic acid type and chlorine type materials for the cover case are not desirable because the former generates corrosive gas of attacking the polarizer at high temperature and the latter causes circuit break by electro-chemical reaction.
- (6) In order to prevent the scratch, do not contact the exposed polarizers with glass, tweezers or anything harder than HB pencil lead. And please do not rub with dust clothes with chemical treatment. Do not touch the surface of polarizer for bare hand or greasy cloth. (Some cosmetics are detrimental to the polarizer.)
- (7) When the surface becomes dusty, please wipe gently with absorbent cotton or other soft materials like chamois soaks with petroleum benzine. Normal-hexane is recommended for cleaning the adhesives used to attach front / rear polarizers. Do not use acetone, toluene and alcohol because they cause chemical damage to the polarizer
- (8) Wipe off saliva or water drops as soon as possible. Their long time contact with polarizer causes deformations and color fading.
- (9) Do not open the case because inside circuits do not have sufficient strength.

#### 9-2. Operating Precautions

- (1) Response time depends on the temperature. (In lower temperature, it becomes longer.)
- (2) Brightness depends on the temperature. (In lower temperature, it becomes lower.)  
And in lower temperature, response time (required time that brightness is stable after turned on) becomes longer
- (3) Be careful for condensation at sudden temperature change. Condensation makes damage to polarizer or electrical contacted parts. And after fading condensation, smear or spot will occur.
- (4) When fixed patterns are displayed for a long time, remnant image is likely to occur.
- (5) Module has high frequency circuits. Sufficient suppression to the electromagnetic interference shall be done by system manufacturers. Grounding and shielding methods may be important to minimize the interference.
- (6) Please do not give any mechanical and/or acoustical impact to LCM. Otherwise, LCM can't be operated its full characteristics perfectly.
- (7) A screw which is fastened up the steels should be a machine screw.  
(if not, it can cause conductive particles and deal LCM a fatal blow)
- (8) Please do not set LCD on its edge.
- (9) The conductive material and signal cables are kept away from LED driver inductor to prevent abnormal display, sound noise and temperature rising.

## Product Specification

### 9-3. Electrostatic Discharge Control

Since a module is composed of electronic circuits, it is not strong to electrostatic discharge. Make certain that treatment persons are connected to ground through wrist band etc. And don't touch interface pin directly.

### 9-4. Precautions for Strong Light Exposure

Strong light exposure causes degradation of polarizer and color filter.

### 9-5. Storage

When storing modules as spares for a long time, the following precautions are necessary.

- (1) Store them in a dark place. Do not expose the module to sunlight or fluorescent light. Keep the temperature between 5°C and 35°C and the humidity between 35%RH and 75%RH.
- (2) The polarizer surface should not come in contact with any other object.  
It is recommended that they be stored in the container in which they were shipped.
- (3) Storage condition is guaranteed under packing conditions.
- (4) The phase transition of Liquid Crystal in the condition of the low or high storage temperature will be recovered when the LCD module returns to the normal condition.

## Product Specification

**9-6. Appropriate Condition for Commercial Display**

- Generally large-sized LCD modules are designed for consumer applications (TV). Accordingly, a long-term display like in Commercial Display application, can cause uneven display including image sticking. To optimize module's lifetime and function, several operating usages are required.

## 1. Normal operating condition

- Temperature: 0 ~ 40°C
- Operating Ambient Humidity : 10 ~ 90 %
- Display pattern: dynamic pattern (Real display)

Note) Long-term static display can cause image sticking.

Be careful for expose the module to sunlight. It causes degradation of polarizer and color filter.

## 2. Operating usages under abnormal condition

## a. Ambient condition

- Well-ventilated place is recommended to set up Commercial Display system.

## b. Power and screen save

- Periodical power-off or screen save is needed after long-term display.

## 3. Operating usages to protect against image sticking due to long-term static display

## a. Suitable operating time: under 24 hours a day.

## b. Static information display recommended to use with moving image.

- Cycling display between 5 minutes' information(static) display and 10 seconds' moving image.

## c. Background and character (image) color change

- Use different colors for background and character, respectively.
- Change colors themselves periodically.

## d. Avoid combination of background and character with large different luminance.

1) Abnormal condition just means conditions except normal condition.

2) Black image or moving image is strongly recommended as a screen save.

4. Lifetime in this spec. is guaranteed only when Commercial Display is used according to operating usages.

5. Module should be turned clockwise based on front view when used in portrait mode.

**(When transporting the assembled product with the LCD module, it must be transported in the same direction as the transport direction of the LCD module)**

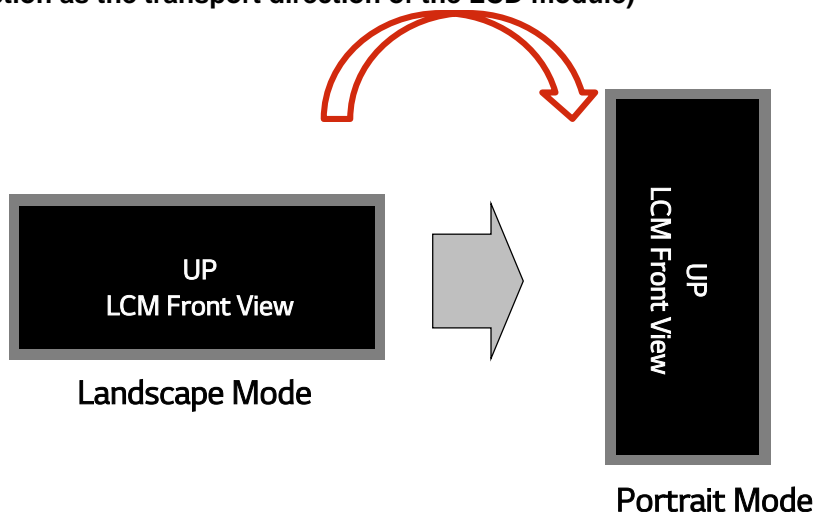

## Product Specification

## # APPENDIX-I-1

## ■ Pallet Ass'y

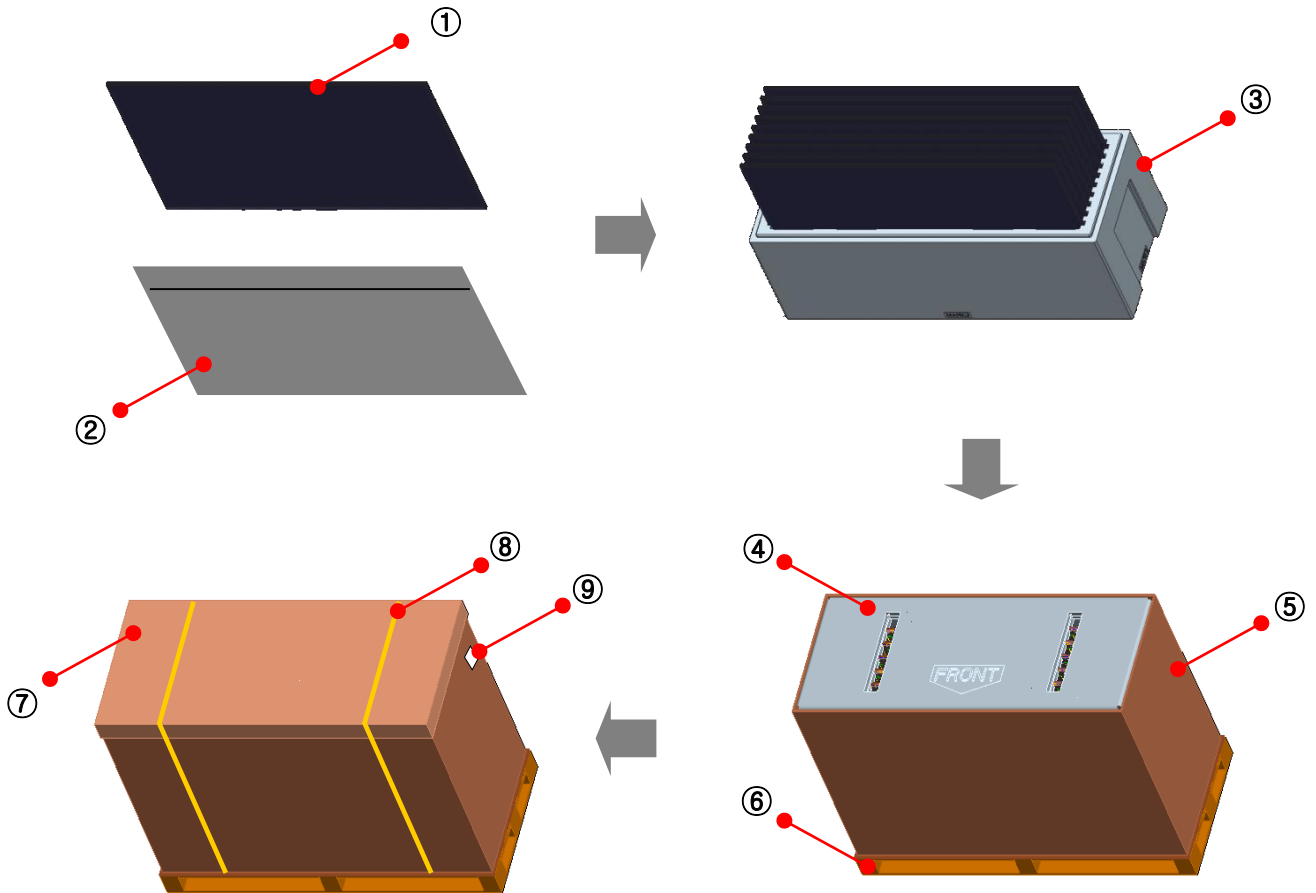

No.	Description	Material
1	LCM	-
2	Bag	Al
3	Bottom Packing	EPS
4	Top Packing	EPS
5	Angle Packing	Paper
6	Pallet	Plywood
7	Angle Cover	Paper
8	Band	PP
9	Label	Yupo Paper 100x70



Product Specification

# APPENDIX- II-1

■ LCM Label



■ Production site

- LG Display (GZ, KTC) Co., LTD

1.The origin of LCM Label will be changed according to the production site.

## Product Specification

## # APPENDIX-II-1

## ■ Pallet Label



## # APPENDIX-III

## ■ Required signal assignment for Flat Link (Thine : THC215) Transmitter

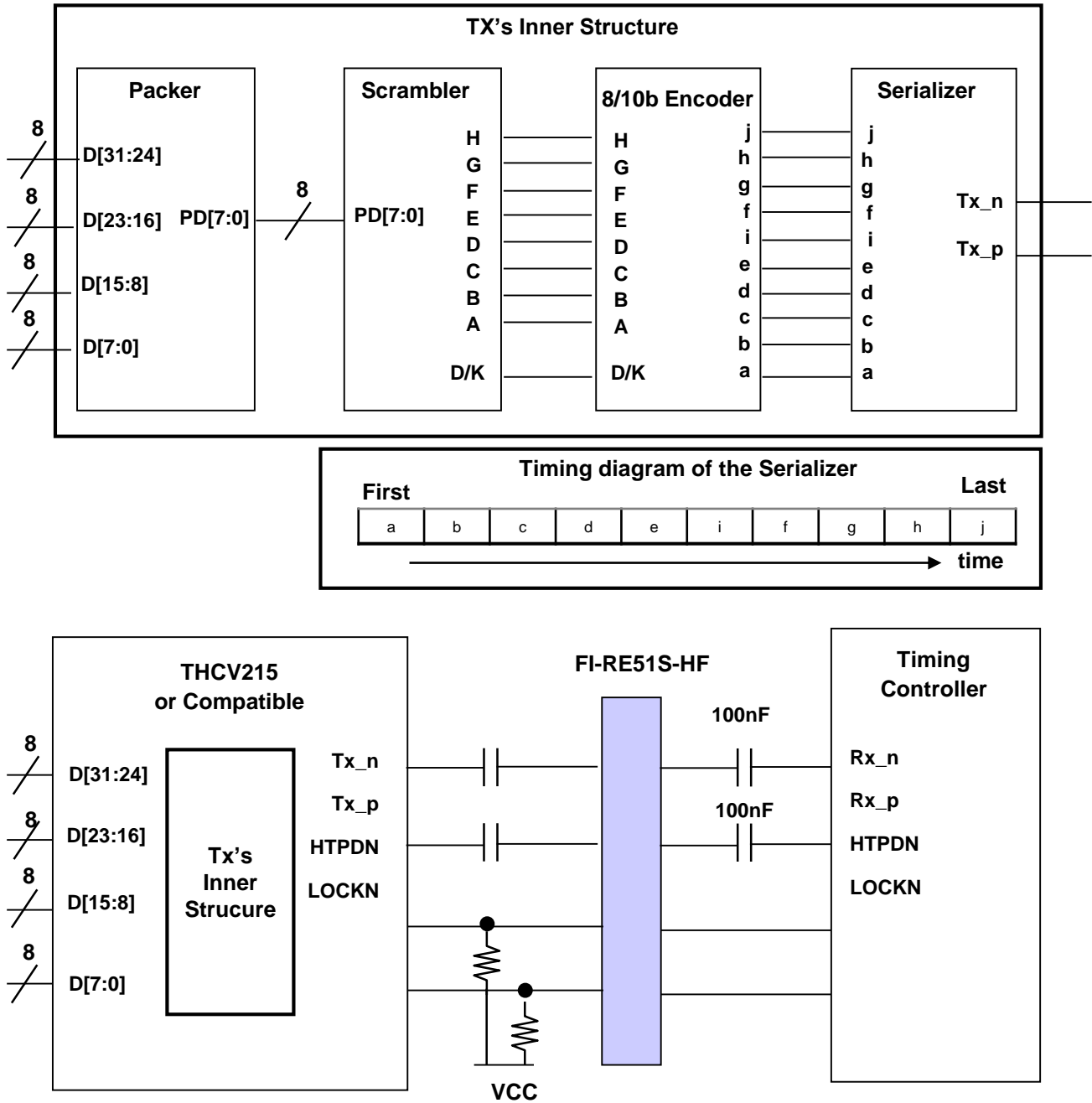

- notes: 1. The LCD module uses a 100 nF capacitor on positive and negative lines of each receiver input.  
 2. Refer to Vx1 Transmitter Data Sheet for detail descriptions. (THCV215 or Compatible)  
 3. About Module connector pin configuration, Please refer to the Page 8~9.

## # APPENDIX- IV-1

## ■ Option Pin Circuit Block Diagram

## 1) Circuit Block Diagram of Data format Selection pin

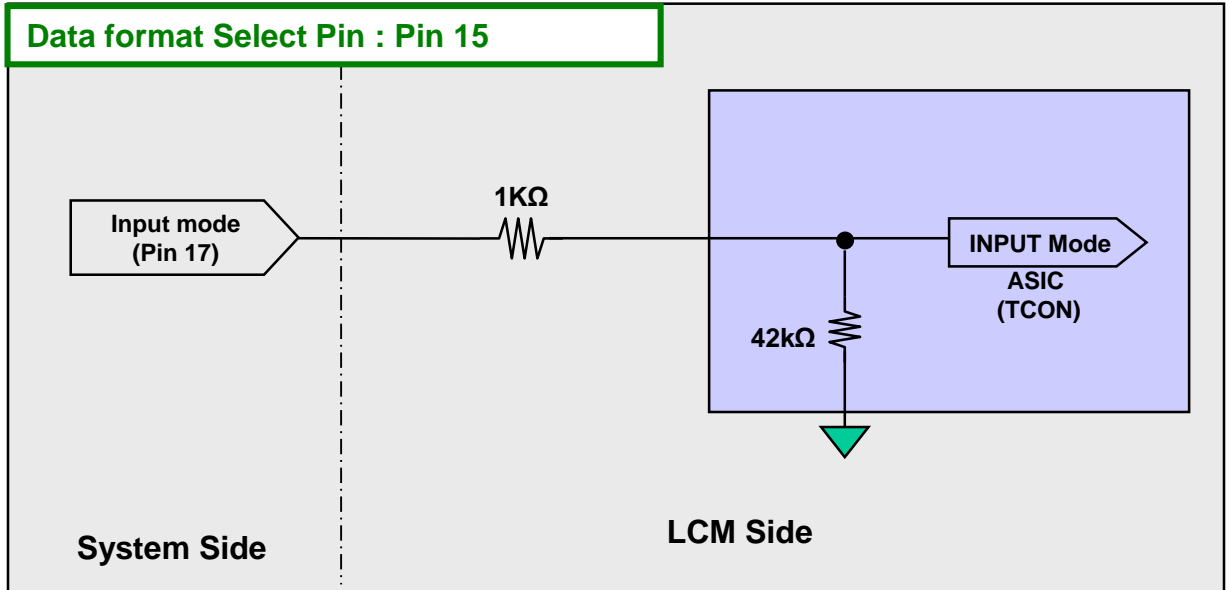

## 2) Circuit Block Diagram of Bit Selection pin

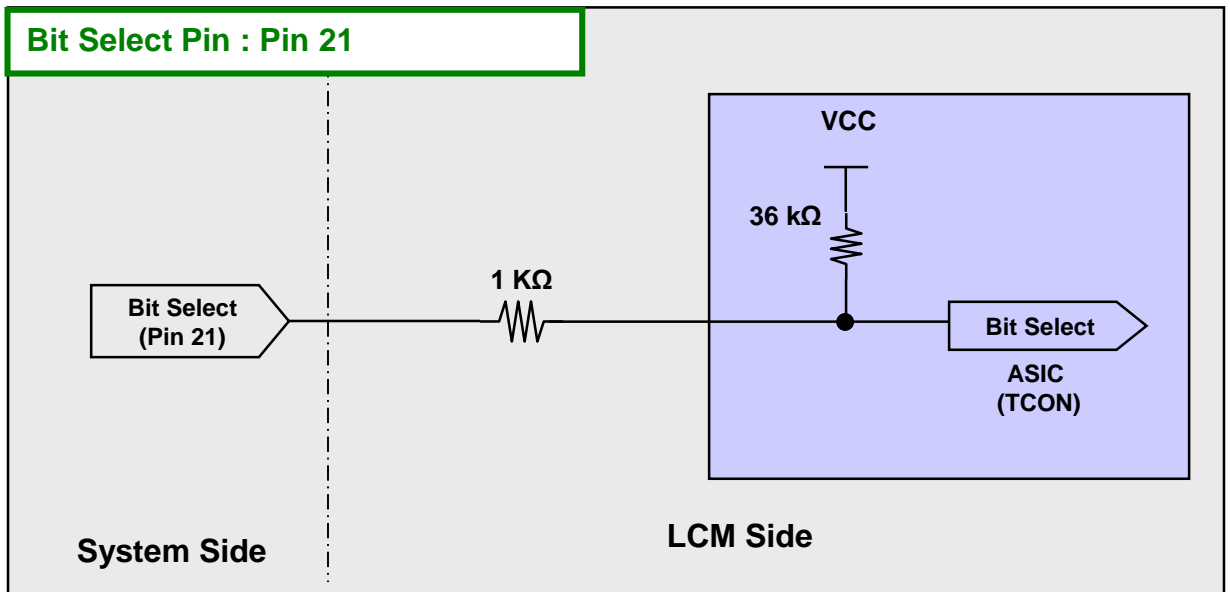

## # APPENDIX- IV-2

## ■ Option Pin Circuit Block Diagram

## 3) Circuit Block Diagram of L-Dim Enable Selection pin

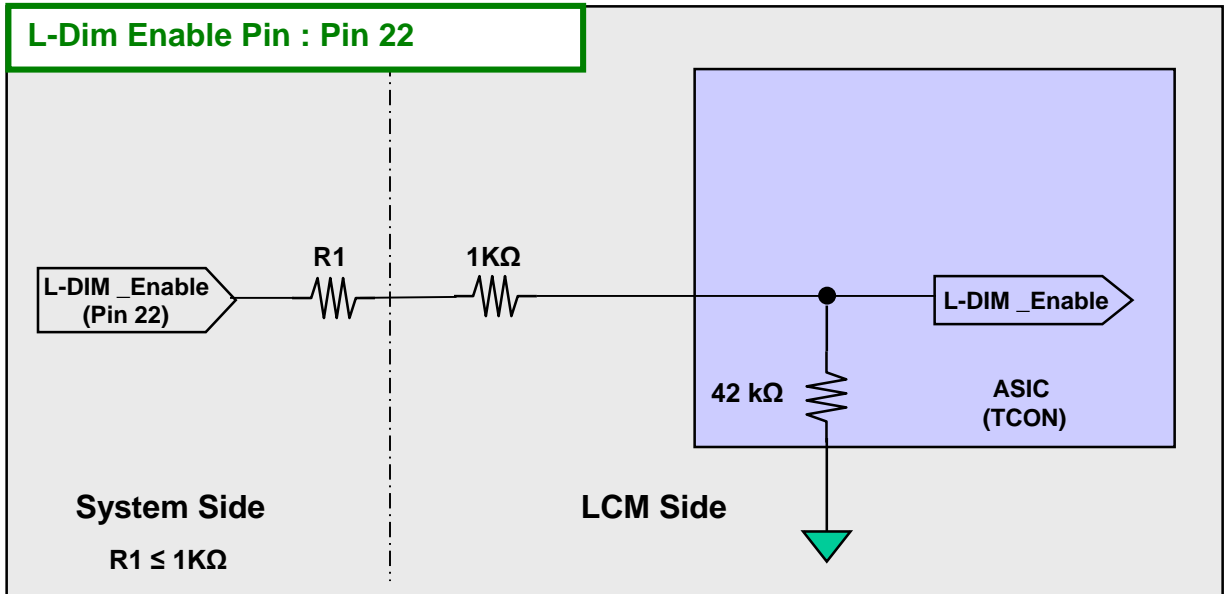

## 4) Circuit Block Diagram of M+ Bypass Selection pin

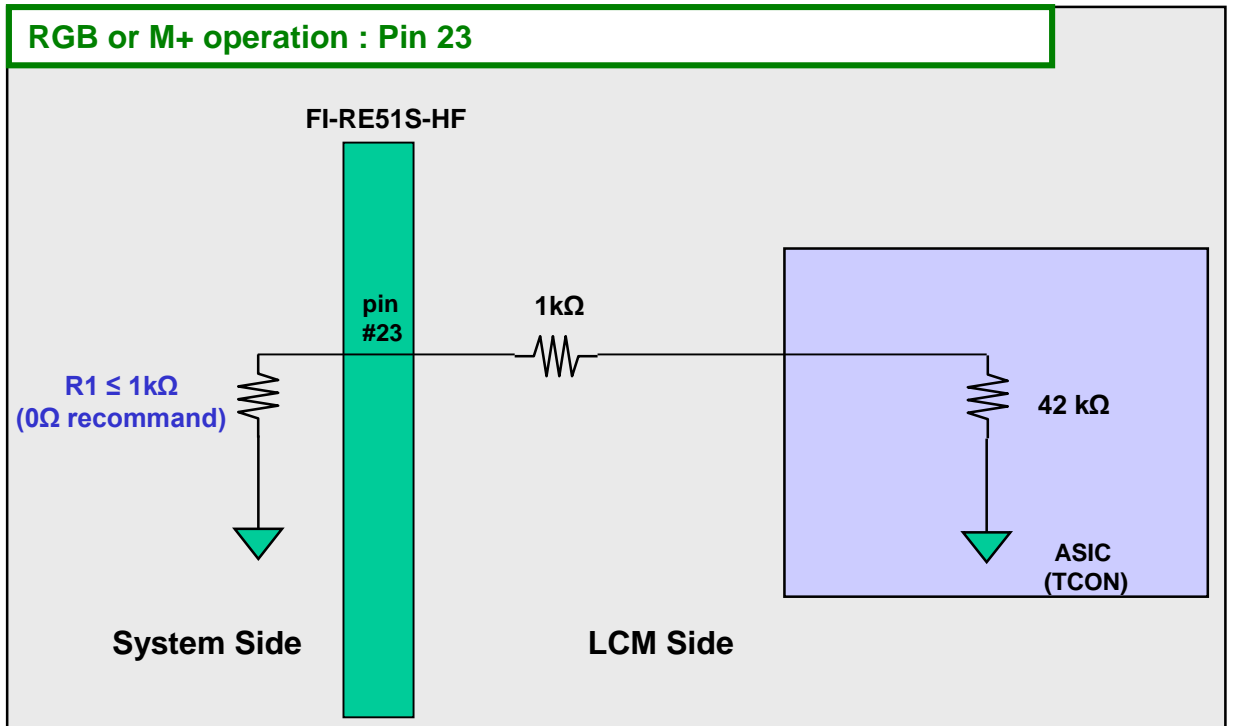

## # APPENDIX- IV-3

## ■ Option Pin Circuit Block Diagram

## 5) Circuit Block Diagram of HTPDN/ LOCKN Selection pin

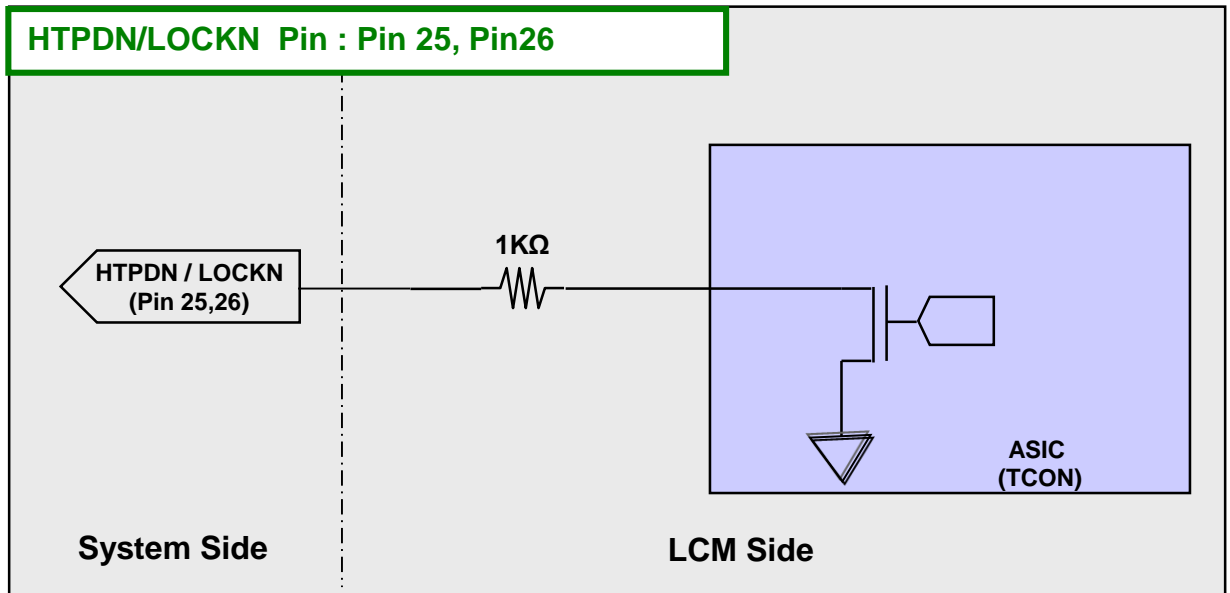

## Product Specification

## # APPENDIX- V

## Gray to Gray Response Time Uniformity

This is only the reference data of G to G and uniformity for LD750DGN-FRH3 model.

### 1. G to G Response Time :

Response time is defined as Figure3 and shall be measured by switching the input signal for "Gray (N) " and "Gray(M)".(32Gray Step at 8bit)

### 2. G to G Uniformity

The variation of G to G Uniformity ,  $\delta_{G \text{ to } G}$  is defined as :

$$\text{G to G Uniformity} = \frac{\text{Maximum}(G \text{ to } G) - \text{Typical}(G \text{ to } G)}{\text{Typical}(G \text{ to } G)} \leq 1$$

\*Maximum (G to G) means maximum value of measured time (N, M = 0 (Black) ~ 1023(White), 128 gray step).

	0Gray	127ray	255Gray	...	895Gray	1023Gray
0Gray		TrR:0G→127G	TrR:0G→255G	...	TrR:0G→895G	TrR:0G→1023G
127Gray	TrD:127G→0G		TrR:127G→255G	...	TrR:127G→895G	TrR:127G→1023G
255Gray	TrD:255G→0G	TrD:255G→127G		...	TrR:255G→895G	TrR:255G→1023G
...	...	...	...	...	...	...
895Gray	TrD:895G→0G	TrD:895G→127G	TrD:895G→255G	...		TrR:895G→1023G
1023Gray	TrD:1023G→0G	TrD:1023G→127G	TrD:1023G→255G	...	TrD:1023G→895G	

### 3. Sampling Size : 1 pcs

4. Measurement Method : Follow the same rule as optical characteristics measurement.

### 5. Current Status

Below table is actual data of production on Oct. 29. 2015( LGD RV Event Sample)

	G to G Response Time [ms]		Uniformity
	Min.	Max.	
# 1	3.0	8.6	0.075

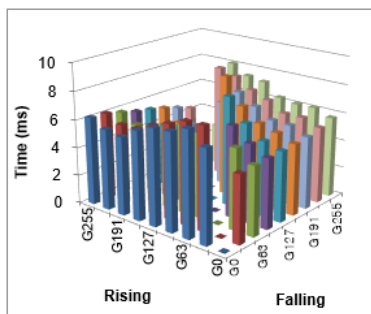

< # 1 >

## Product Specification

## # APPENDIX-VI

## ■ input mode of pixel data

## Mode 1 : Non-Division

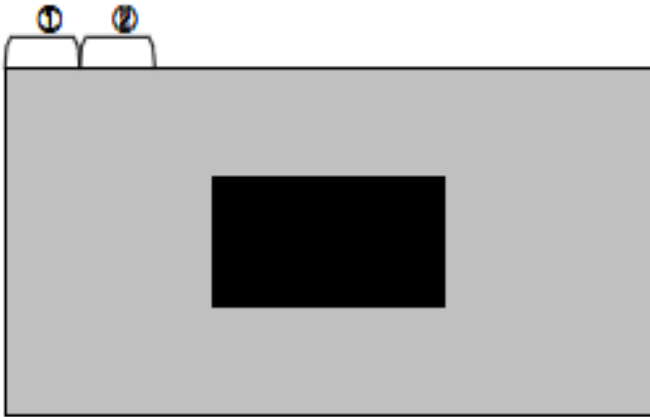

Lane	1 <sup>st</sup> Data	2 <sup>nd</sup> Data	Data#
Lane0	1	9	3833
Lane1	2	10	3834
Lane2	3	11	3835
Lane3	4	12	3836
Lane4	5	13	3837
Lane5	6	14	3838
Lane6	7	15	3839
Lane7	8	16	3840

## Mode 2 : 2 Division

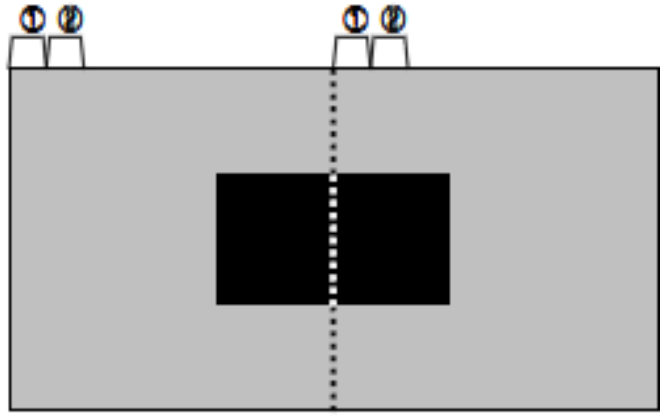

Lane	1 <sup>st</sup> Data	2 <sup>nd</sup> Data	Data#
Lane0	1	5	1917
Lane1	2	6	1918
Lane2	3	7	1919
Lane3	4	8	1920
Lane4	1921	1925	3837
Lane5	1922	1926	3838
Lane6	1923	1927	3839
Lane7	1924	1928	3840



## Product Specification

## # APPENDIX-VII-1

## ■ Vx1 Initialization Characteristics

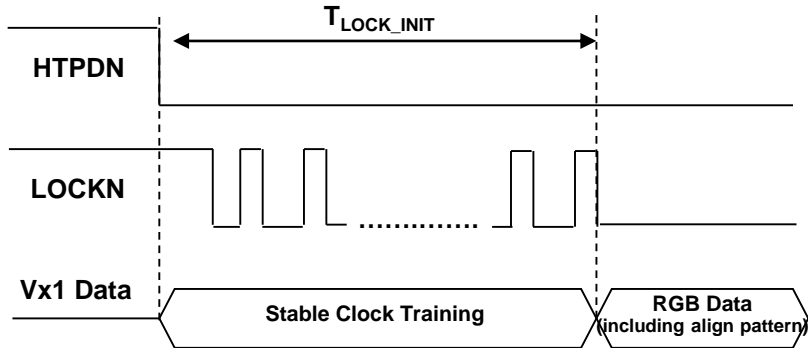

## UHD60Hz T-Con

Characteristics	Symbol	Min	Typ	Max	Unit
Initial CDR lock time (From Stable CDR training to CDR lock)	$T_{LOCK\_INIT}$	0		310	ms

## # APPENDIX-VII-2

## ■ Vx1 Lock Timing In Normal Operation

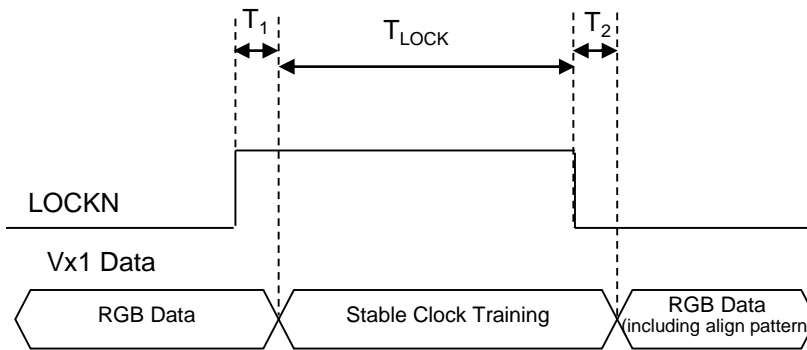

Characteristics	Symbol	Min	Typ	Max	Unit
CDR lock time from stable clock training pattern to LOCKN "Low" in normal operation	$T_{LOCK}$			2	ms
Latency from LOCKN "High" to clock training pattern	$T_1$			100	us
Latency from clock "Low" to normal RGB Data	$T_2$			100	us

※ Vx1 Rx should get clock training pattern in  $T_1$

※ Vx1 Rx should get RGB Data (including align pattern) in  $T_2$



ALL TECHNOLOGIES. ALL COMPETENCIES. ONE SPECIALIST.



DATA MODUL AG  
Landsberger Straße 322 DE-  
80687 Munich  
Phone: +49-89-56017-0

DATA MODUL WEIKERSHEIM GMBH  
Lindenstraße 8  
DE-97990 Weikersheim Phone:  
+49-7934-101-0



More information and worldwide locations can be found at

[www.data-modul.com](http://www.data-modul.com)