

TO : Customer

DATE : 2018.01.23

**GREEN C&C TECH Co.,Ltd
65,JINWISANDAN-RO , JINWI-MYEON
PYEONGTAEK-CITY, KYEONGGI-DO
KOREA 451-861
TEL : 82-31-373-3623~3625
FAX : 82-31-373-3610**

DOCUMENTATION FOR APPROVAL

**PRODUCT : LED BACKLIGHT DRIVER (RoHS)
MODEL NAME : GH523A(A35)
GCCT NAME : GCCT523BJ**

APPROVAL	CHECKED	WRITTEN

PLEASE RETURN ONE DOCUMENT AFTER APPROVED SIGN.

GREEN C&C TECH	LED DRIVER SPECIFICATION GH523A(A35)	Publishing Date Reforming Date	2018.01.23
----------------	---	-----------------------------------	------------

NO	Date	REVISION	Page
REVISION HISTORY			

REV.														
Page														
REV.	0	0	0	0	0	0	0	0	0	0	0	0	0	0
Page	1	2	3	4	5	6	7	8	9	10	11	12	13	14
Page Rev.												0	Page	1

GREEN C&C TECH	LED DRIVER SPECIFICATION GH523A(A35)	Publishing Date	2018.01.23
		Reforming Date	

1. APPLICATION

This Document Specified The Detailed Product Requirement of LED driver
GH523A(A35)

2. SUITABLE LOAD

LCD MODULE : 4 Strings LED BLU TFT LCD

3. ELECTRICAL CHARATERISTICS

3.1. Absolute Maximum Ratings

Item	Symbol	Spec.	Unit	Remarks
Input Voltage 1	Vin	10.8~26.4	V	
Input Voltage 2	ON/OFF	5.25	V	
Operating Temperature	Top	0~60	℃	
Storage Temperature	Tstg	-30~80	℃	
Relative Humidity	RH	80	%	

3.2. Control Signal

PIN No.	Symbol	Status	Action	Remarks
CN1 #9	ON/OFF	HIGH	LED - ON	2.4 ~ 5.25V
		LOW	LED - OFF	0.8 V Max

GREEN C&C TECH	LED DRIVER SPECIFICATION GH523A(A35)	Publishing Date	2018.01.23
		Reforming Date	

3.3. Output Characteristics

Item	Sym.	Condition	Min.	Typ.	Max.	Unit
Input Voltage	Vin	-	10.8	-	26.4	Vdc
Input Current	Iin	Vin=12V, Dim=0V	-	-	0.8	A
Output Current	Iout (Max)	Vin=12V, Dim=0V	35.0	40.0	45.0	mAmean
	Iout (Min)	Vin=12V, Dim=5V	16.0	21.0	26.0	
Backlight ON/OFF Control	ON	-	2.4	-	5.25	Vdc
	OFF	-	-0.3	-	0.8	

* Output Voltage is greater than Input Voltage for at least 3V or more.

3.4. Test Circuit

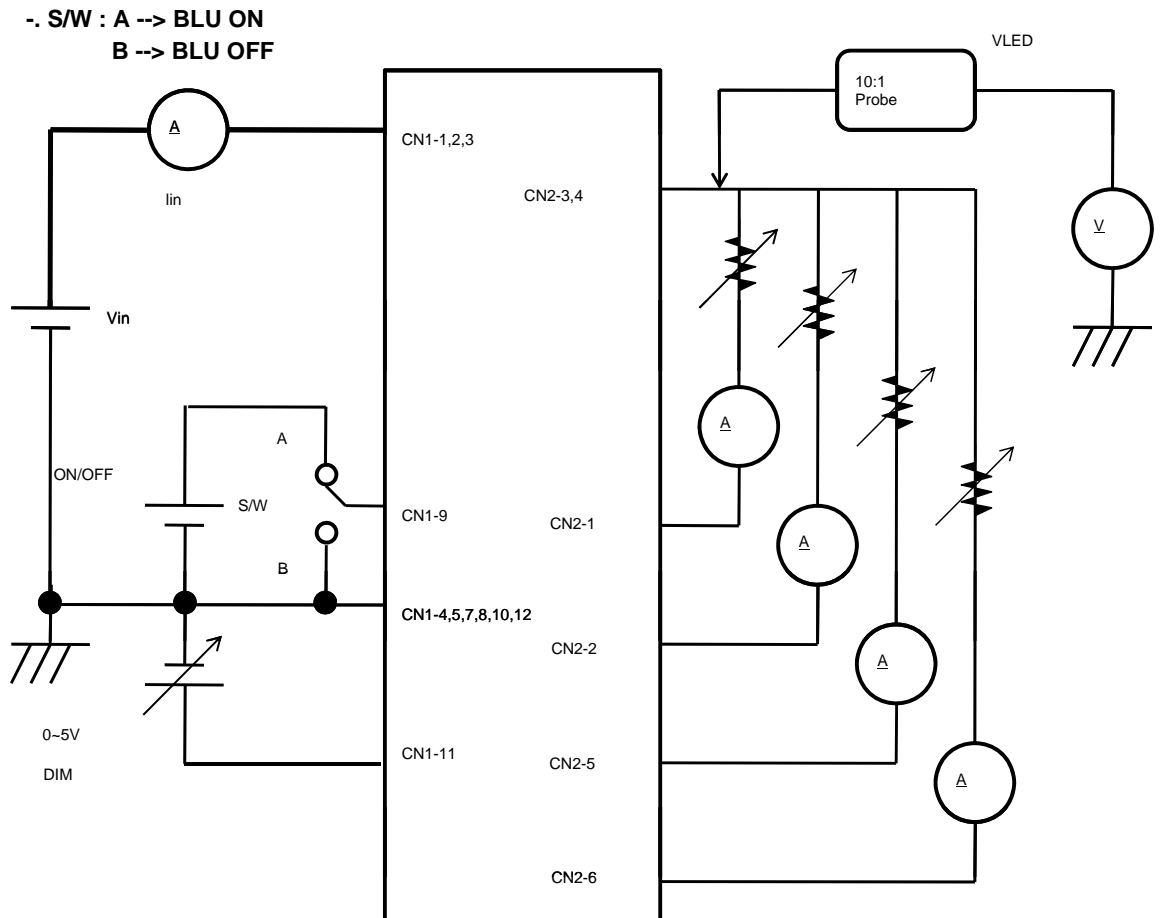

GREEN C&C TECH	LED DRIVER SPECIFICATION GH523A(A35)	Publishing Date Reforming Date	2018.01.23
----------------	---	-----------------------------------	------------

4. INTERFACE

4.1. CN1 Connector (Input) : 12505WR-12A (YEONHO) or Equivalent

PIN No.	Symbol	Description
1,2,3	VIN	Voltage Input : 12V, 24V (typ.)
4,5,7,8,10,12	GND	Ground
6	N.C	No Connection
9	ON/OFF	LED DRIVER ON/OFF Control
11	DIM	0V(MAX)~5V(MIN)

4.2. CN2 Connector (Output) : 12507WR-06L (YEONHO) or Equivalent

PIN No.	Symbol	Description
1	FB1	Feedback 1 (Return 1)
2	FB2	Feedback 2 (Return 2)
3	VLED	System Output
4	VLED	System Output
5	FB3	Feedback 3 (Return 3)
6	FB4	Feedback 4 (Return 4)

GREEN C&C TECH	LED DRIVER SPECIFICATION GH523A(A35)	Publishing Date Reforming Date	2018.01.23
----------------	---	-----------------------------------	------------

5. APPERANCE (Unit : mm)

(Tolerance : +0.8mm, -0.2mm)

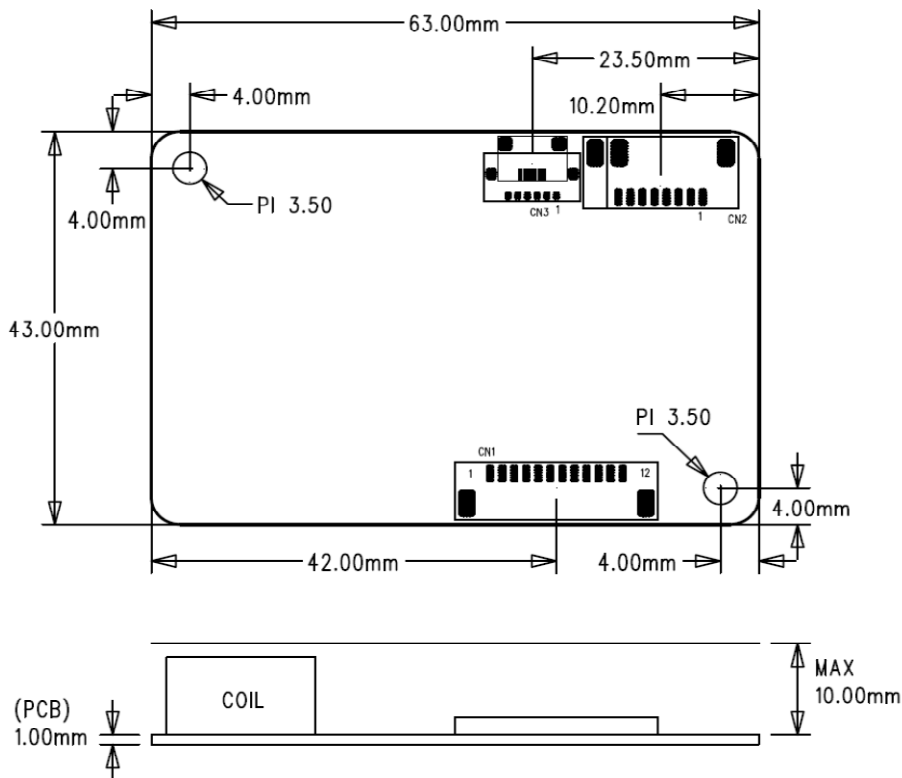

6. NOTATION OF LOT NUMBER

MARKING:BOTTOM



GH523A(A35)	: USER MODEL CODE
G	: MANUFACTURER CODE (GREEN C&C TECH.)
8	: YEAR OF PRODUCT 6 → 2016 , 7 → 2017 , ... , 9 → 2019
02	: WEEK OF PRODUCT 01,02,03,04,...52
A	: PUBLICATION NUMBER A,B,C,...,Z,0,1,2,...,9
0001	: SERIAL NUMBER 0001,0002.....9998,9999
BJ	: GCCT MODEL CODE (GCCT523BJ)

GREEN C&C TECH	LED DRIVER SPECIFICATION GH523A(A35)	Publishing Date	2018.01.23
		Reforming Date	

7. PART LIST

SYMBOL	NAME	1st		2nd	
		TYPE No	MAKER	TYPE No	MAKER
U1	IC	MP3391EF	MPS		
Q1	FET	AP9997GH	APEC	MDD1903RH	MAGNACHIP
		AOD478	AOS	AM20N10	Analog Power
		APM1110NUA3	ANPEC		
Q2	TR	SST2907A	ROHM	KTN2907AS	KEC
		MMBT2907A	DIODES	SBT2907A	AUK
		MMBT2907A	PANJIT	MMBT2907ALT1G	ONSEMI
D1	DIODE	B290	DIODES	MB29	PANJIT
		B2100	DIODES	MB210	PANJIT
		SS210	TSC	B290	LITEON
		B2100	LITEON	SK29	PANJIT
C1	C-ELEC	NXH Series 220uF/35V	SAMYOUNG	Equivalent	
C16		NXA Series 15uF/100V	SAMYOUNG	"	
C2,C4	MLCC	GRM21BR61E225K	MURATA	Equivalent	
C3		GRM219R71E105K	"	"	
C5,C6,C8		GRM188R61E105K	"	"	
C7		GRM188R71H103K	"	"	
C9		GRM188R71H104K	"	"	
C14		GRM1885C1H101J	"	"	
C15		GRM31CR72A105K	"	"	
R1		CHIP-R	RC2012J100	ROHM	Equivalent
R3,R12	RC1608J224		"	"	
R4,R5	RC1608J513		"	"	
R6,R9,R18,R21, R22	RC1608J104		"	"	
R7	RC1608J124		"	"	
R10	RC1608J273		"	"	
R11	RC1608J102		"	"	
R13	RC1608J184		"	"	
R14	RC1608J393		"	"	
R15	RC1608J753		"	"	
R16	RC1608J101		"	"	
R17	RC1608J100		"	"	
R19,R20	RC3216FR20		"	"	
R23	RC1608J512		"	"	

GREEN C&C TECH	LED DRIVER SPECIFICATION GH523A(A35)	Publishing Date	2018.01.23
		Reforming Date	

SYMBOL	NAME	1st		2nd	
		TYPE No	MAKER	TYPE No	MAKER
F1	FUSE	CCF1N4	KOA	CB61F4A	Cooper Bussmann
		451004	LITTELFUSE	453004	LITTELFUSE
L1	Inductor	SPI-1260SDN-470	SEJIN	Equivalent	
L2		SPI-3516RS-100	SEJIN	"	
CN1	Connector	12505WR-12A	YEONHO	Equivalent	
CN2		12507WR-06L	YEONHO	"	
PCB	PCB	GH523A REV1.0	SEOKANG	GH523A REV1.0	WONKYUNG
		GH523A REV1.0	JDM	GH523A REV1.0	TECOS

GREEN C&C TECH	LED DRIVER SPECIFICATION GH523A(A35)	Publishing Date Reforming Date	2018.01.23
----------------	---	-----------------------------------	------------

8. PCB LAYOUT

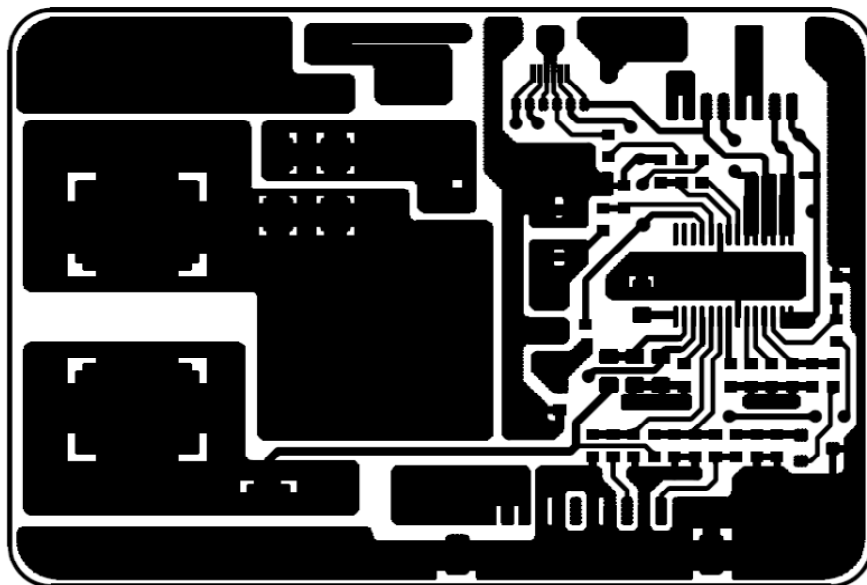

TOP LAYER

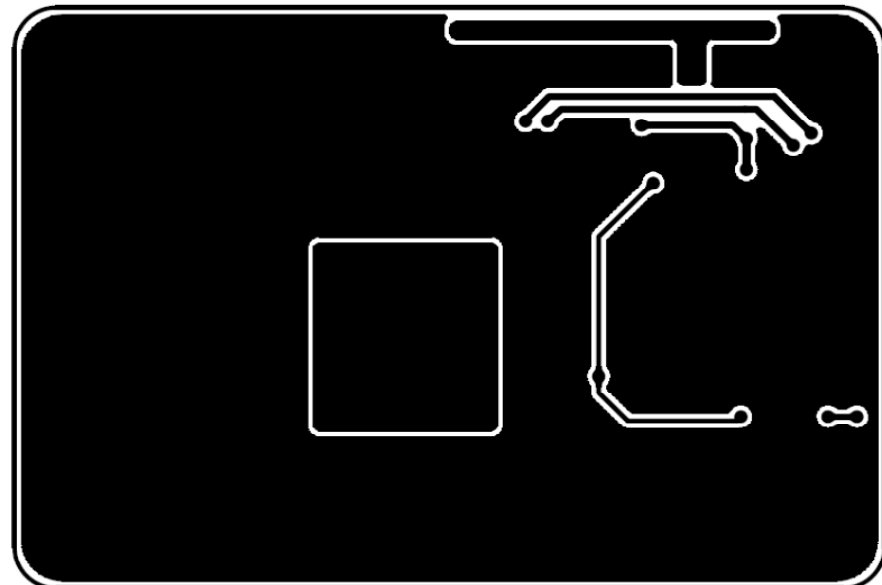

BOTTOM LAYER

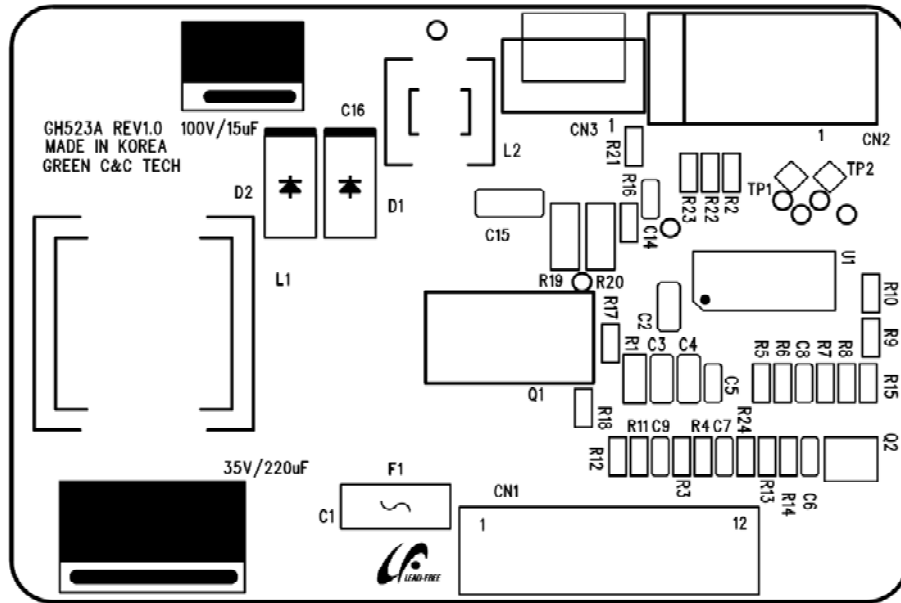

SILK SCREEN TOP

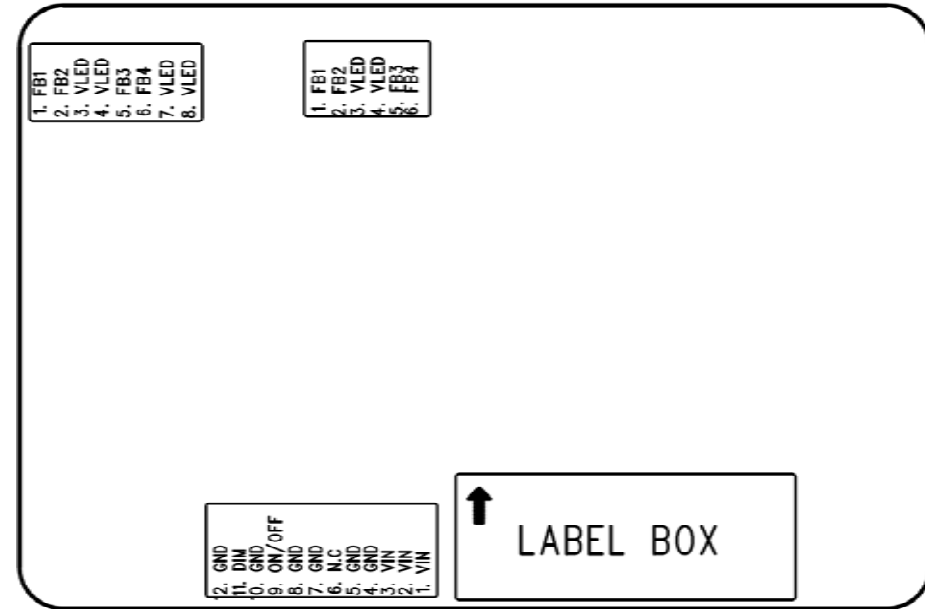

SILK SCREEN BOTTOM

GREEN C&C TECH	LED DRIVER SPECIFICATION GH523A(A35)	Publishing Date Reforming Date	2018.01.23
----------------	---	-----------------------------------	------------

10. RELIABILITY TEST SPEC.

NO.	ITEM	Conditions and Method
1	High Temperature Storage Test	Temp : 80 °C Duration : 250hrs
2	Low Temperature Storage Test	Temp : -30 °C Duration : 250hrs
3	High Temperature High Humidity Operation Test	Temp : 60 °C Humidity : 95%RH Duration : 250hrs
4	Signal On/Off Test	Temp : Normal Temperature On-Off Signal On 10sec / Off 10sec Power on full Load 30,000 cycles
5	Thermal Shock Test	Temp : -20 °C ↔ 70 °C, 100 cycles (30min) (30min)
6	High Temperature Operation Test	Temp : 60 °C Duration : 250hrs
7	Low Temperature Operation Test	Temp : 0 °C Duration : 250hrs

GREEN C&C TECH	LED DRIVER SPECIFICATION GH523A(A35)	Publishing Date	2018.01.23
		Reforming Date	





11. FLOW CHART

MODEL (TYPE)	GH523A(A35)	REVISION	5
WRITER	T.W.LEE	FLOW CHART	
FLOW CHART	PROCESS	EQUIPMENTS	Remark
	Raw Material		PART LIST
	Solder Printing	Cream-solder Printer	
	Surface Mounting	Low-high Mounter	
	Reflow Soldering (CTQ)	Reflower	
	Visual Inspection (AOI)	Microscope, Vision-Master	
	Label attachment	Marking	
	Preparing Process		
	Soldering by Hand for Discrete Parts		
	Spreading Silicon	Silicon Dispenser	
	Insert Lead Parts		
	Wave-Soldering	Wave-Soldering Machine	
	Visual Inspection		
	PCB Division		
	Aging	Power Supply, Aging Box	2hrs
	Electrical Characteristics inspection	Testing System, Testing JIG	
	Insulator Attachment		
	Bar-Code Reading	Bar-Code Reader	
	Package		
	Outgoing Inspection	Testing System, Testing JIG	List of Inspection
	Shipping		
Based on Standard Rule	GCCT523BJ		

GREEN C&C TECH	LED DRIVER SPECIFICATION GH523A(A35)	Publishing Date	2018.01.23
		Reforming Date	

12. PACKING

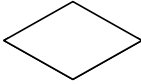
12.1. BOX

 LEAD-FREE			 L/C NO : C/T NO : MADE IN KOREA
1. Customer			
2. PART NAME	GH523A(A35)		
3. PO NO			
4. Q'ty	000 EA		
5. Date	00.00.00		
6. LOT NO			

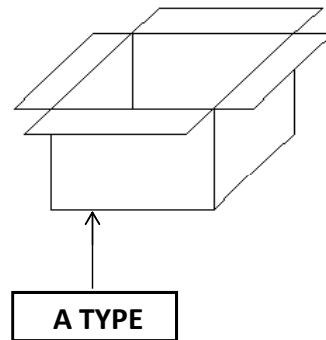

12.2. TRAY

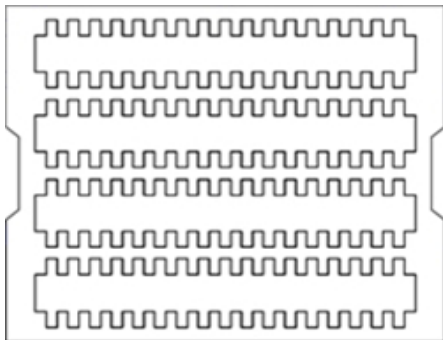

SYMBOL	TYPE NO
PACKING-TRAY	393*324*53
PACKING-BOX	415*340*332
PACKING-PAD	393*324*3

1 TRAY : 68EA (GR2052)
 1BOX : 6 TRAY (408EA) - A TYPE

GREEN C&C TECH	LED DRIVER SPECIFICATION GH523A(A35)	Publishing Date Reforming Date	2018.01.23
----------------	---	-----------------------------------	------------

13. Material list for safety GH523A(A35)

SYMBOL	NAME	TYPE No	MANUFACTURER	DESCRIPTION
F1	FUSE	CCF1N4	KOA	UL FILE NO. : E171861
		451004	LITTELFUSE	UL FILE NO. : E10480 CSA FILE NO : LR29862
		453004	LITTELFUSE	UL FILE NO. : E10480 CSA FILE NO : LR29862
		CB61F4A	COOPER BUSSNANN	UL FILE NO. : E19180
PCB	Printed Writing Board	FR4	SEOKANG	UL FILE NO. : E150774
			WONKYUNG	UL FILE NO. : E202541
			JDM	UL FILE NO. : E343057
			TECOS	UL FILE NO. : E214879
CN1	Connector	12505WR-12A	YEONHO	UL FILE NO. : E108706
CN2	Connector	12507WR-06L	YEONHO	UL FILE NO. : E108706