

Doc. Number :

- Tentative Specification
- Preliminary Specification
- Approval Specification

MODEL NO.: M195FGE
SUFFIX: L20

Customer: All	
APPROVED BY	SIGNATURE
<u>Name / Title</u> _____	_____
Note Product Version C5	
<hr/> Please return 1 copy for your confirmation with your signature and comments.	

Approved By	Checked By	Prepared By
梁永祥	林秋森	勞美玉

CONTENTS

1. GENERAL DESCRIPTION	6
1.1 OVERVIEW	6
1.2 GENERAL SPECIFICATIONS	6
2. MECHANICAL SPECIFICATIONS	6
3. ABSOLUTE MAXIMUM RATINGS	7
3.1 ABSOLUTE RATINGS OF ENVIRONMENT	7
3.2 ELECTRICAL ABSOLUTE RATINGS	8
3.2.1 TFT LCD MODULE	8
3.2.2 BACKLIGHT UNIT	8
4. ELECTRICAL SPECIFICATIONS	8
4.1 FUNCTION BLOCK DIAGRAM	8
4.2. INTERFACE CONNECTIONS	9
4.3 ELECTRICAL CHARACTERISTICS	10
4.3.1 LCD ELETRONICS SPECIFICATION	10
4.3.2 VCC POWER DIP CONDITION	13
4.3.3 BACKLIGHT UNIT	13
4.3.4 LIGHTBAR CONNECTOR PIN ASSIGNMENT	14
4.4 LVDS INPUT SIGNAL SPECIFICATIONS	15
4.4.1 LVDS DATA MAPPING TABLE	15
4.4.2 COLOR DATA INPUT ASSIGNMENT	16
4.5 DISPLAY TIMING SPECIFICATIONS	17
4.6 POWER ON/OFF SEQUENCE	19
5. OPTICAL CHARACTERISTICS	20
5.1 TEST CONDITIONS	20
5.2 OPTICAL SPECIFICATIONS	20
6. RELIABILITY TEST ITEM	23
7. MECHANICAL STRENGTH CHARACTERISTICS	24
7.1 MECHANICAL STRENGTH SPECIFICATIONS	24
7.2 TEST CONDITIONS	24
7.3 DEFINITION OF TEST POINTS	24
8. PACKING	25
8.1 PACKING SPECIFICATIONS	25
8.2 PACKING METHOD	25
8.3 PALLET	26
8.4 UN-PACKING METHOD	27

9. CMI MODULE LABEL	28
10. PRECAUTIONS	29
10.1 ASSEMBLY AND HANDLING PRECAUTIONS	29
10.2 STORAGE PRECAUTIONS	29
10.3 OPERATION PRECAUTIONS	29
10.4 SAFETY PRECAUTIONS	30
10.5 SAFETY STANDARDS	30
10.6 OTHER	30
Appendix 1. SYSTEM COVER DESIGN NOTICE	30
Appendix 2. OUTLINE DRAWING	33

REVISION HISTORY

Version	Date	Page	Description
3.0	2013.Jan	5	1.2 GENERAL SPECIFICATIONS To modify Power Consumption : Total 14.09 W (Max.) → 13.54 W cell 5.25W (Max.) → 4.7W
		8	4.2. INTERFACE CONNECTION To modify Connector Information - Mating housing part number
		9	4.3.1 LCD ELETRONICS SPECIFICATION To modify Power Supply Current (typ/max) Black : 0.77/0.87 → 0.83/0.94 A V-strip : 0.91/1.05 → 0.62/0.69 A To modify Power Consumption(typ/max) 4.55/5.25 → 4.15/4.7 Watt
		11	4.3.1 LCD ELETRONICS SPECIFICATION Modify description of Note(5) & update figure
		13	4.3.4 LIGHTBAR Connector Pin Assignment Add Connector Information:
		19	5.2 OPTICAL SPECIFICATIONS Color Chromaticity (CIE 1931) Modify Rx、Gx、By
3.1	2013.April	13	4.3.4 LIGHTBAR Connector Pin Assignment Connector Information: Remove vender - Entry
		23	7.1 Mechanical Strength Specifications Modify description of specification from "Min" to "Force"
		31	Appendix 2. Update 2D drawing for change of PCBA protector film
3.2	2013.May	8	4.2. INTERFACE CONNECTIONS To modify Connector Information – Removing FCN connector
		26	Add 8.4 UN-PACKING METHOD
3.3	2014.Dec	24	8.2 PACKING METHOD To modify packing method –Anti Static Bag length openings to short edge opening
		25	8.3 PALLET Add 2 pc Corner Protector
		27	9. CMI MODULE LABEL Add 4 fool-proof wires
3.4	2015.Nov	6	1.2 GENERAL SPECIFICATIONS Add Display Orientation & Note(2).

			Modify power consumption total 13.54W to 11.64W. Modify BL Power Consumption(max) 8.84W to 6.94W.
		7	3.1 ABSOLUTE RATINGS OF ENVIRONMENT Note(1) (a) item delete ($T_a \leq 40\text{ }^\circ\text{C}$) , (b) item delete ($T_a > 40\text{ }^\circ\text{C}$)
		8	3.2.2 BACKLIGHT UNIT Modify LED push current(max) 200mA to 500mA
		13	4.3.3 BACKLIGHT UNIT Modify LED Light Bar Input Voltage 31V to 25.4V, (max)34V to 26.7V Modify Power Consumption (type)8.06W to 6.60W, (max) 8.84W to 6.94W
		25	8.2 PACKING METHOD Delete (1)the standard of Carton Packing reliability test.
		29	10.2 STORAGE PRECAUTIONS Modify note(1) discretion from less than 70% to less than 90%

1. GENERAL DESCRIPTION

1.1 OVERVIEW

M195FGE-L20 is a 19.5" TFT Liquid Crystal Display module with WLED Backlight unit and 30 pins 2ch-LVDS interface. This module supports 1600 x 900 HD+ mode and can display up to 16.7M colors. The converter module for Backlight is not built in.

1.2 GENERAL SPECIFICATIONS

Item	Specification	Unit	Note
Screen Size	19.452" real diagonal		
Driver Element	a-si TFT active matrix	-	-
Pixel Number	1600 x R.G.B. x 900	pixel	-
Pixel Pitch	0.27 (H) x 0.27 (V)	mm	-
Pixel Arrangement	RGB vertical stripe	-	-
Display Colors	16.7M	color	-
Transmissive Mode	Normally white	-	-
Surface Treatment	AG type, 3H hard coating, Haze 25	-	-
Luminance, White	250	Cd/m2	
Color Gamut	72% of NTSC(Typ.)	-	-
Display Orientation	Signal input with "INX"		(2)
RoHS, Halogen Free & TCO	RoHS, Halogen Free TCO 6.0 compliance		
Power Consumption	Total 11.64W (Max.) @ cell 4.7W (Max.), BL 6.94W (Max.)		(1)

Note (1) The specified power consumption : Total= cell (reference 4.3.1)+BL (reference 4.3.3)

Note (2)

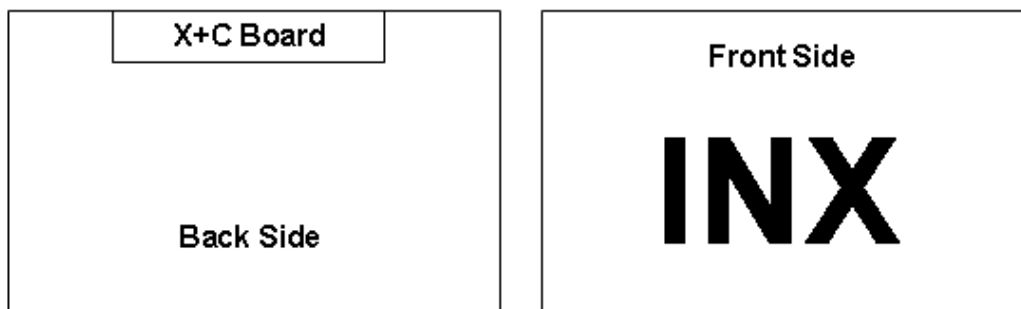

2. MECHANICAL SPECIFICATIONS

Item	Min.	Typ.	Max.	Unit	Note	
Module Size	Horizontal (H)	451.5	452.0	452.5	mm	(1)
	Vertical (V)	262.5	263.0	263.5	mm	
	Thickness (T)	-	10.5	11	mm	
Bezel Area	Horizontal	434.8	435.3	435.8	mm	
	Vertical	242.56	243.06	243.56	mm	
Active Area	Horizontal	-	432.0	-	mm	
	Vertical	-	239.76	-	mm	
Weight	-	1430	1500	g		

Note (1) Please refer to the attached drawings for more information of front and back outline dimensions.

3. ABSOLUTE MAXIMUM RATINGS

3.1 ABSOLUTE RATINGS OF ENVIRONMENT

Item	Symbol	Value		Unit	Note
		Min.	Max.		
Storage Temperature	TST	-20	60	°C	(1)
Operating Ambient Temperature	TOP	0	50	°C	(1), (2)

Note (1)

(a) 90 %RH Max.

(b) Wet-bulb temperature should be 39 °C Max.

(c) No condensation.

Note (2) Panel surface temperature should be 0°C min. and 65°C max under Vcc=5.0V, fr =60Hz, typical LED string current, 25°C ambient temperature, and no humidity control . Any condition of ambient operating temperature ,the surface of active area should be keeping not higher than 65°C .

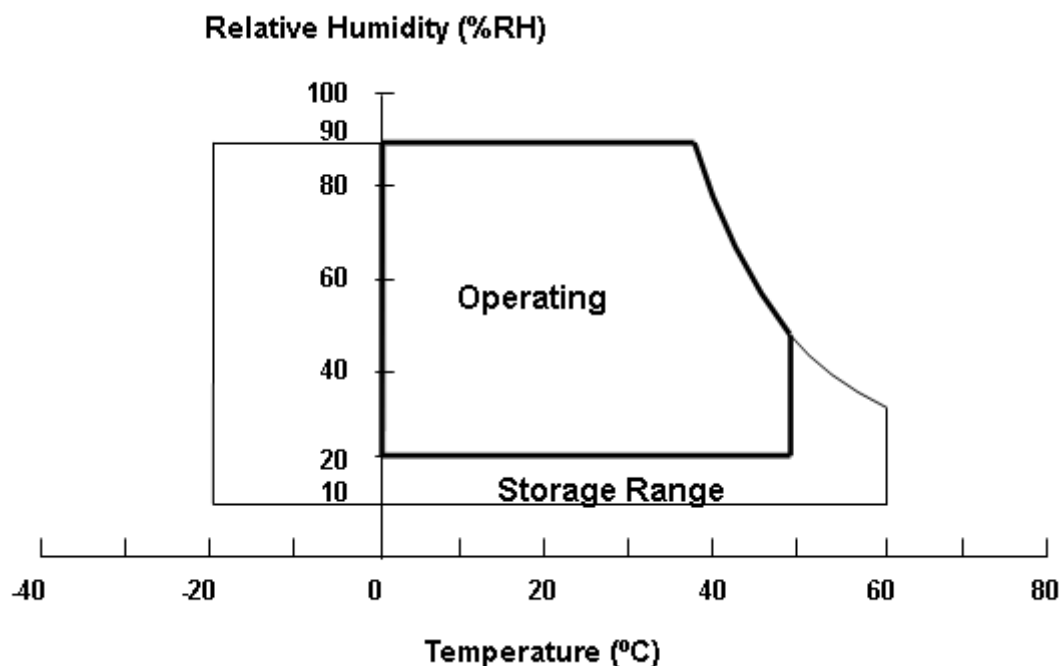

3.2 ELECTRICAL ABSOLUTE RATINGS

3.2.1 TFT LCD MODULE

Item	Symbol	Value		Unit	Note
		Min.	Max.		
Power Supply Voltage	VCCS	-0.3	6.0	V	(1)
Logic Input Voltage	V _{IN}	-0.3	3.6	V	

3.2.2 BACKLIGHT UNIT

Item	Symbol	Value			Unit	Note
		Min.	Typ	Max.		
LED Forward Current Per Input Pin	I _F	0	65	69	mA	(1), (2) Duty=100%
LED Pulse Forward Current Per Input Pin	I _P	---	---	500	mA	(1), (2) Pulse Width ≤ 10msec. and Duty ≤ 10%

Note (1) Permanent damage to the device may occur if maximum values are exceeded. Function operation should be restricted to the conditions described under Normal Operating Conditions.

Note (2) Specified values are for input pin of LED light bar at Ta=25±2 °C (Refer to 4.3.3 and 4.3.4 for further information).

4. ELECTRICAL SPECIFICATIONS

4.1 FUNCTION BLOCK DIAGRAM

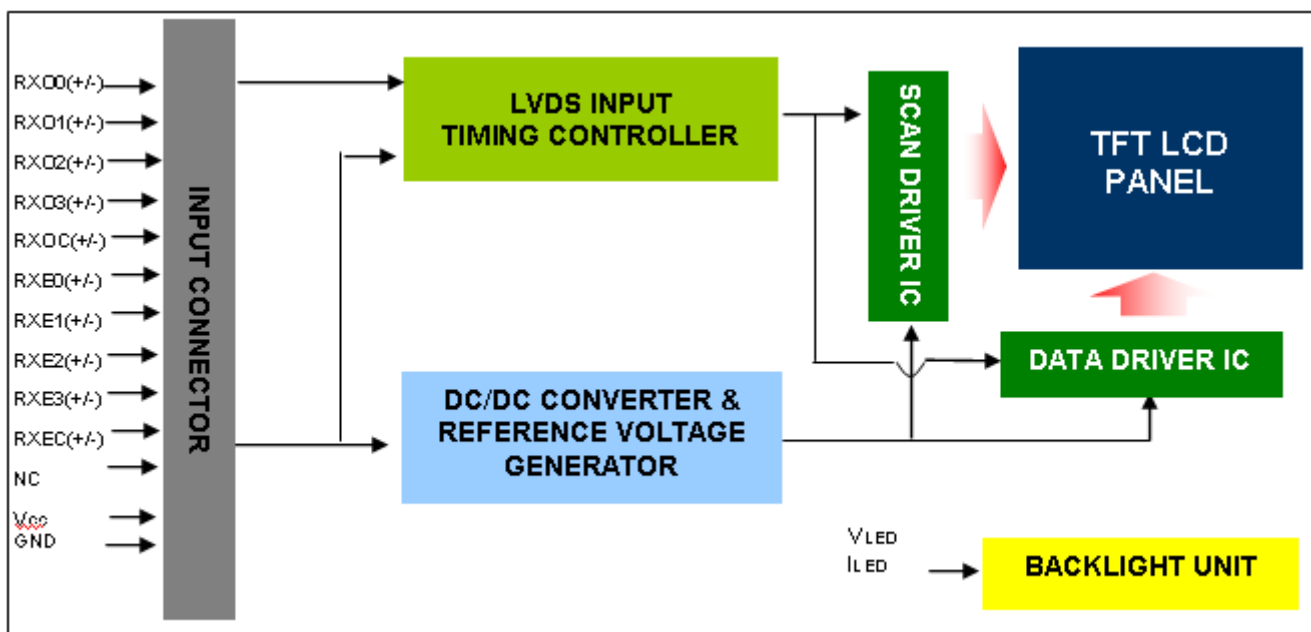

4.2. INTERFACE CONNECTIONS

PIN ASSIGNMENT

Pin	Name	Description
1	RXO0-	Negative LVDS differential data input. Channel O0 (odd)
2	RXO0+	Positive LVDS differential data input. Channel O0 (odd)
3	RXO1-	Negative LVDS differential data input. Channel O1 (odd)
4	RXO1+	Positive LVDS differential data input. Channel O1 (odd)
5	RXO2-	Negative LVDS differential data input. Channel O2 (odd)
6	RXO2+	Positive LVDS differential data input. Channel O2 (odd)
7	GND	Ground
8	RXOC-	Negative LVDS differential clock input. (odd)
9	RXOC+	Positive LVDS differential clock input. (odd)
10	RXO3-	Negative LVDS differential data input. Channel O3(odd)
11	RXO3+	Positive LVDS differential data input. Channel O3 (odd)
12	RXE0-	Negative LVDS differential data input. Channel E0 (even)
13	RXE0+	Positive LVDS differential data input. Channel E0 (even)
14	GND	Ground
15	RXE1-	Negative LVDS differential data input. Channel E1 (even)
16	RXE1+	Positive LVDS differential data input. Channel E1 (even)
17	GND	Ground
18	RXE2-	Negative LVDS differential data input. Channel E2 (even)
19	RXE2+	Positive LVDS differential data input. Channel E2 (even)
20	RXEC-	Negative LVDS differential clock input. (even)
21	RXEC+	Positive LVDS differential clock input. (even)
22	RXE3-	Negative LVDS differential data input. Channel E3 (even)
23	RXE3+	Positive LVDS differential data input. Channel E3 (even)
24	GND	Ground
25	NC	For LCD internal use only, Do not connect
26	NC	For LCD internal use only, Do not connect
27	NC	For LCD internal use only, Do not connect
28	Vcc	+5.0V power supply
29	Vcc	+5.0V power supply
30	Vcc	+5.0V power supply

Connector Information

Item	Description
Manufacturer	P-TWO/ Foxconn
Type part number	P-TWO:187098-30091 Foxconn:GS23301-0321R-7H
Mating housing part number	FI-X30HL(JAE) P-TWO 27 代(P-TWO)

*Notice: There would be compatible issues, if not using the indicated connectors in the matching list.

Note (1) The first pixel is odd.

Note (2) Input signal of even and odd clock should be the same timing.

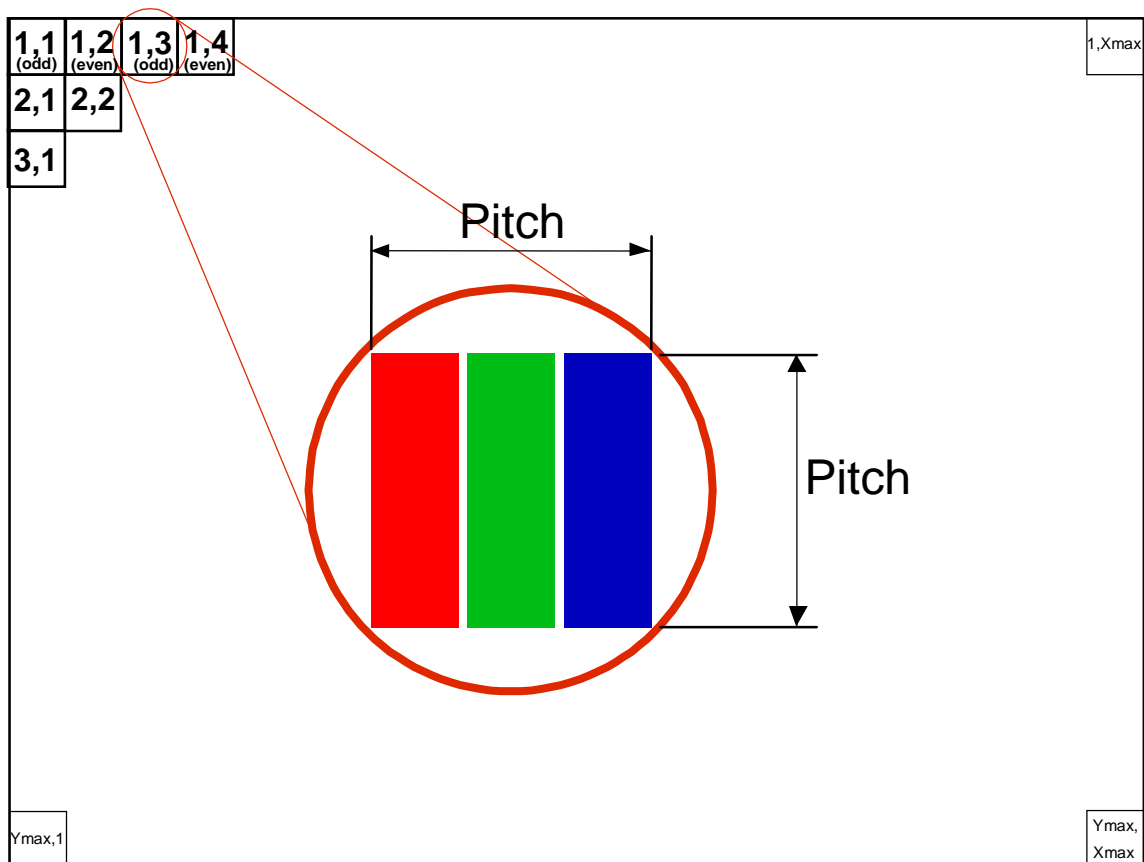

4.3 ELECTRICAL CHARACTERISTICS

4.3.1 LCD ELETRONICS SPECIFICATION

Parameter	Symbol	Value			Unit	Note	
		Min.	Typ.	Max.			
Power Supply Voltage	V _{CC}	4.5	5.0	5.5	V	-	
Ripple Voltage	V _{RP}	-	-	300	mV	-	
Rush Current	I _{RUSH}	-	-	3	A	(2)	
Power Supply Current	White	-	0.43	0.48	A	(3)a	
	Black	-	0.83	0.94	A	(3)b	
	Vertical Stripe	-	0.62	0.69	A	(3)c	
Power Consumption	PLCD	-	4.15	4.7	Watt	(4)	
LVDS interface	Differential Input Voltage	V _{ID}	100	-	600	mV	
	Common Input Voltage	V _{CM}	1.0	1.2	1.4	V	
	Differential Input High Threshold Voltage	V _{TH}	-	-	+100	mV	
	Differential Input Low Threshold Voltage	V _{TL}	-100	-	-	mV	

Note (1) The ambient temperature is $T_a = 25 \pm 2$ °C.

Note (2) Measurement Conditions:

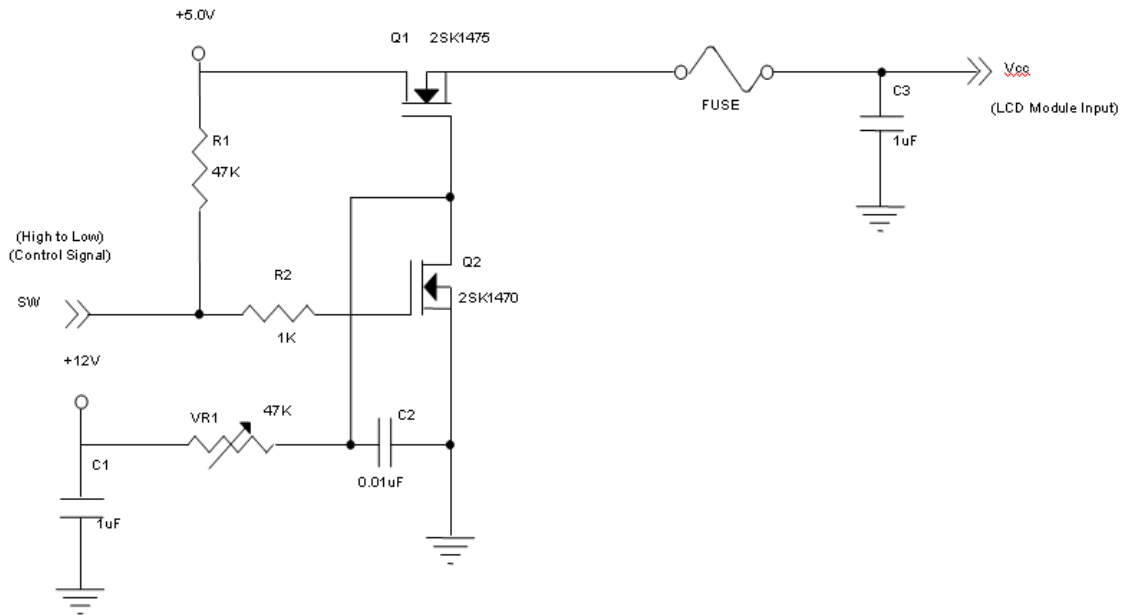

Vcc rising time is 470μs

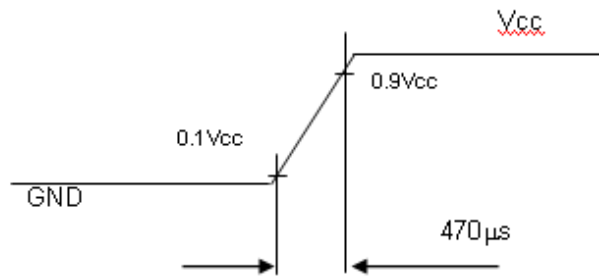

Note (3) The specified power supply current is under the conditions at $V_{cc} = 5.0\text{ V}$, $T_a = 25 \pm 2\text{ }^\circ\text{C}$, $F_r = 75\text{ Hz}$, whereas a power dissipation check pattern below is displayed.

a. White Pattern



Active Area

b. Black Pattern

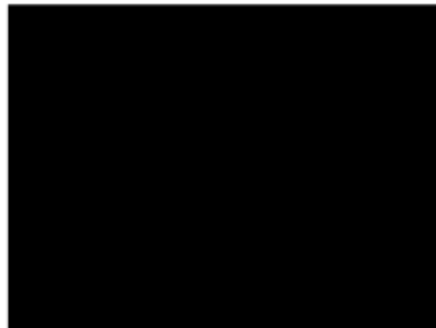

Active Area

c. Vertical Stripe Pattern

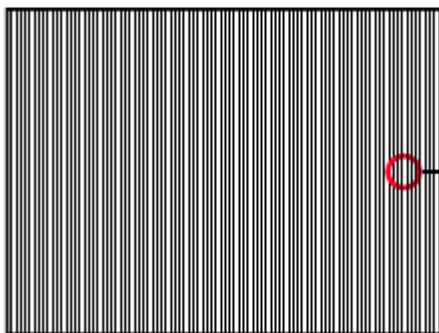

Active Area

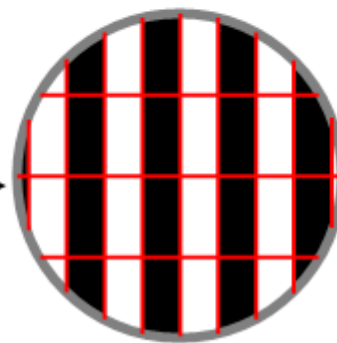

Note (4) The power consumption is specified at the pattern with the maximum current.

Note (5) The LVDS input characteristics are as follows:

Single-end Signals

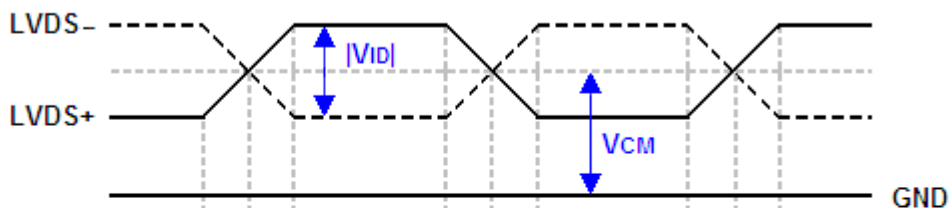

Differential Signal

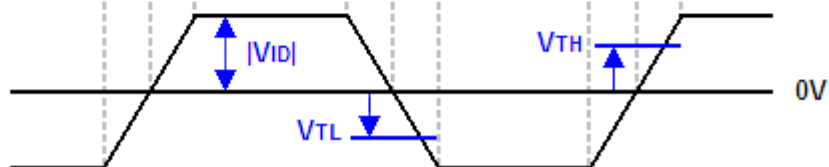

4.3.2 VCC POWER DIP CONDITION

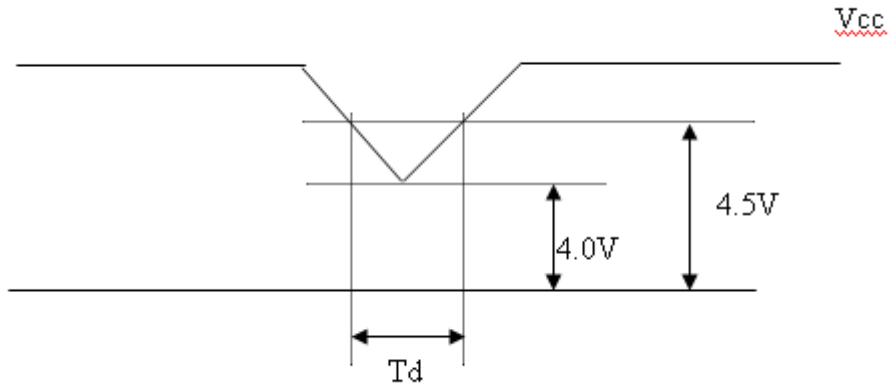

Dip condition: $4.0 \leq V_{cc} \leq 4.5$, $T_d \leq 20ms$

4.3.3 BACKLIGHT UNIT

Parameter	Symbol	Value			Unit	Note
		Min.	Typ.	Max.		
LED Light Bar Input Voltage Per Input Pin	VPIN	---	25.4	26.7	V	(1), Duty=100%, IPIN=65mA
LED Light Bar Current Per Input Pin	IPIN		65	69	mA	(1), (2) Duty=100%
LED Life Time	LLED	40000			Hrs	(3)
Power Consumption	PBL	---	6.60	6.94	W	(1) Duty=100%, IPIN=65mA

Note (1) LED light bar input voltage and current are measured by utilizing a true RMS multimeter as shown below:

Note (2) $PBL(Typ) = IPIN(Typ) \times VPIN(Typ) \times (4)$ $PBL(Max) = IPIN(Typ) \times VPIN(Max) \times (4)$ input pins ,

Note (3) The lifetime of LED is defined as the time when LED packages continue to operate under the conditions at $T_a = 25 \pm 2 \text{ }^\circ\text{C}$ and $I = (65)\text{mA}$ (per chip) until the brightness becomes $\leq 50\%$ of its original value.

Note (4) The module must be operated with constant driving current.

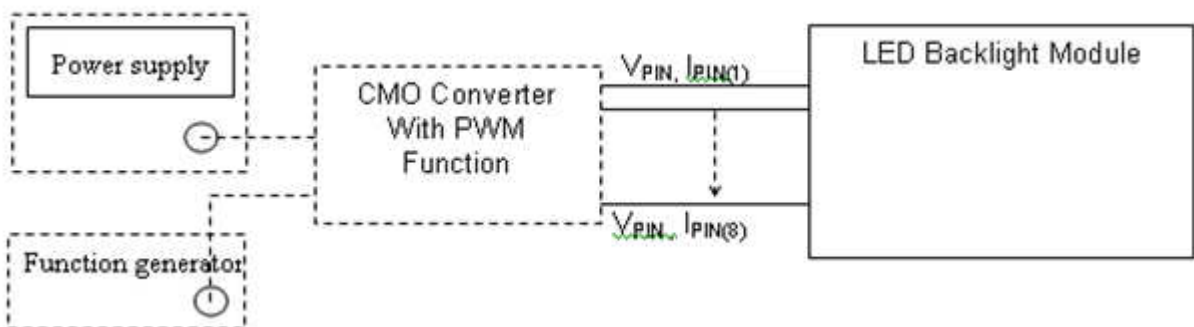

4.3.4 LIGHTBAR CONNECTOR PIN ASSIGNMENT

(1) Connector Information:

Item	Description
Manufacturer	FCN / CviLux
Type part number	WM13-406-063N(FCN) / C11406M1HRK-NH(CviLux)
Mating housing part number	WF1300106-B (FCN) / C11406SL000-NH (CviLux).

*Notice: There would be compatible issues if not using the indicated connectors in the matching list.

(2) LB Connector drawing:

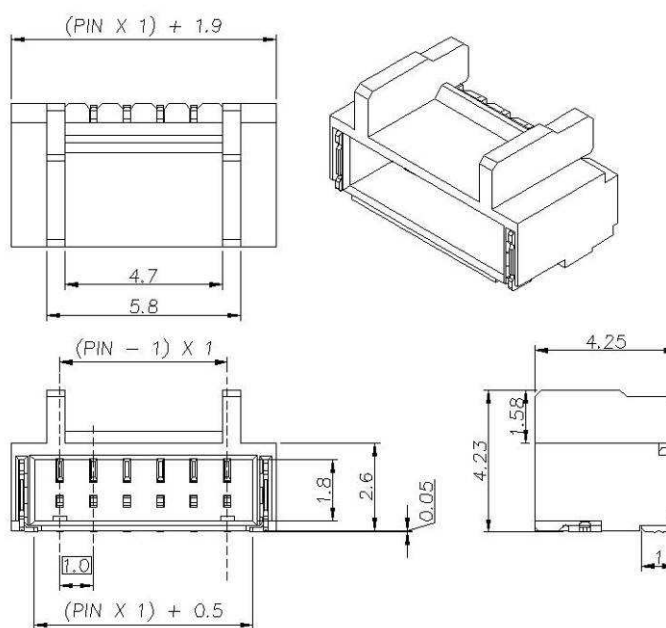

Pin number	Description
1	Cathode of LED string1
2	Cathode of LED string2
3	VLED
4	VLED
5	Cathode of LED string3
6	Cathode of LED string4

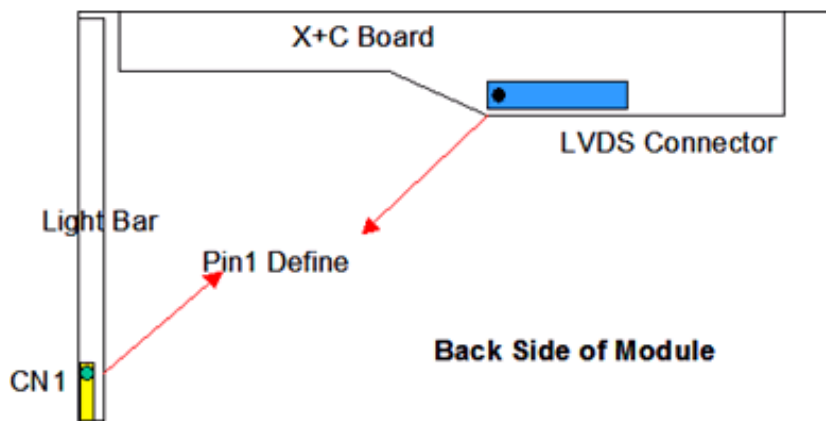

4.4 LVDS INPUT SIGNAL SPECIFICATIONS

4.4.1 LVDS DATA MAPPING TABLE

LVDS Channel O0	LVDS output	D7	D6	D4	D3	D2	D1	D0
	Data order	OG0	OR5	OR4	OR3	OR2	OR1	OR0
LVDS Channel O1	LVDS output	D18	D15	D14	D13	D12	D9	D8
	Data order	OB1	OB0	OG5	OG4	OG3	OG2	OG1
LVDS Channel O2	LVDS output	D26	D25	D24	D22	D21	D20	D19
	Data order	DE	NA	NA	OB5	OB4	OB3	OB2
LVDS Channel O3	LVDS output	D23	D17	D16	D11	D10	D5	D27
	Data order	NA	OB7	OB6	OG7	OG6	OR7	OR6
LVDS Channel E0	LVDS output	D7	D6	D4	D3	D2	D1	D0
	Data order	EG0	ER5	ER4	ER3	ER2	ER1	ER0
LVDS Channel E1	LVDS output	D18	D15	D14	D13	D12	D9	D8
	Data order	EB1	EB0	EG5	EG4	EG3	EG2	EG1
LVDS Channel E2	LVDS output	D26	D25	D24	D22	D21	D20	D19
	Data order	DE	NA	NA	EB5	EB4	EB3	EB2
LVDS Channel E3	LVDS output	D23	D17	D16	D11	D10	D5	D27
	Data order	NA	EB7	EB6	EG7	EG6	ER7	ER6

4.4.2 COLOR DATA INPUT ASSIGNMENT

The brightness of each primary color (red, green and blue) is based on the 8-bit gray scale data input for the color. The higher the binary input, the brighter the color. The table below provides the assignment of color versus data input.

Color		Data Signal																							
		Red								Green								Blue							
		R7	R6	R5	R4	R3	R2	R1	R0	G7	G6	G5	G4	G3	G2	G1	G0	B7	B6	B5	B4	B3	B2	B1	B0
Basic Colors	Black	0	0	0	0	0	0	0	0	0	0	0	0	0	0	0	0	0	0	0	0	0	0	0	0
	Red	1	1	1	1	1	1	1	1	0	0	0	0	0	0	0	0	0	0	0	0	0	0	0	0
	Green	0	0	0	0	0	0	0	0	1	1	1	1	1	1	1	1	0	0	0	0	0	0	0	0
	Blue	0	0	0	0	0	0	0	0	0	0	0	0	0	0	0	0	1	1	1	1	1	1	1	1
	Cyan	0	0	0	0	0	0	0	0	1	1	1	1	1	1	1	1	1	1	1	1	1	1	1	1
	Magenta	1	1	1	1	1	1	1	1	0	0	0	0	0	0	0	0	1	1	1	1	1	1	1	1
	Yellow	1	1	1	1	1	1	1	1	1	1	1	1	1	1	1	1	0	0	0	0	0	0	0	0
	White	1	1	1	1	1	1	1	1	1	1	1	1	1	1	1	1	1	1	1	1	1	1	1	1
Gray Scale Of Red	Red(0) / Dark	0	0	0	0	0	0	0	0	0	0	0	0	0	0	0	0	0	0	0	0	0	0	0	
	Red(1)	0	0	0	0	0	0	1	0	0	0	0	0	0	0	0	0	0	0	0	0	0	0	0	
	Red(2)	0	0	0	0	0	1	0	0	0	0	0	0	0	0	0	0	0	0	0	0	0	0	0	
	⋮	⋮	⋮	⋮	⋮	⋮	⋮	⋮	⋮	⋮	⋮	⋮	⋮	⋮	⋮	⋮	⋮	⋮	⋮	⋮	⋮	⋮	⋮	⋮	
	⋮	⋮	⋮	⋮	⋮	⋮	⋮	⋮	⋮	⋮	⋮	⋮	⋮	⋮	⋮	⋮	⋮	⋮	⋮	⋮	⋮	⋮	⋮	⋮	
	⋮	⋮	⋮	⋮	⋮	⋮	⋮	⋮	⋮	⋮	⋮	⋮	⋮	⋮	⋮	⋮	⋮	⋮	⋮	⋮	⋮	⋮	⋮	⋮	
	Red(253)	1	1	1	1	1	1	0	1	0	0	0	0	0	0	0	0	0	0	0	0	0	0	0	
	Red(254)	1	1	1	1	1	1	1	0	0	0	0	0	0	0	0	0	0	0	0	0	0	0	0	
Red(255)	1	1	1	1	1	1	1	1	0	0	0	0	0	0	0	0	0	0	0	0	0	0	0		
Gray Scale Of Green	Green(0) / Dark	0	0	0	0	0	0	0	0	0	0	0	0	0	0	0	0	0	0	0	0	0	0	0	
	Green(1)	0	0	0	0	0	0	0	0	0	0	0	0	0	0	1	0	0	0	0	0	0	0	0	
	Green(2)	0	0	0	0	0	0	0	0	0	0	0	0	0	1	0	0	0	0	0	0	0	0	0	
	⋮	⋮	⋮	⋮	⋮	⋮	⋮	⋮	⋮	⋮	⋮	⋮	⋮	⋮	⋮	⋮	⋮	⋮	⋮	⋮	⋮	⋮	⋮	⋮	
	⋮	⋮	⋮	⋮	⋮	⋮	⋮	⋮	⋮	⋮	⋮	⋮	⋮	⋮	⋮	⋮	⋮	⋮	⋮	⋮	⋮	⋮	⋮	⋮	
	⋮	⋮	⋮	⋮	⋮	⋮	⋮	⋮	⋮	⋮	⋮	⋮	⋮	⋮	⋮	⋮	⋮	⋮	⋮	⋮	⋮	⋮	⋮	⋮	
	Green(253)	0	0	0	0	0	0	0	0	1	1	1	1	1	1	0	1	0	0	0	0	0	0	0	
	Green(254)	0	0	0	0	0	0	0	0	1	1	1	1	1	1	1	0	0	0	0	0	0	0	0	
Green(255)	0	0	0	0	0	0	0	0	1	1	1	1	1	1	1	1	0	0	0	0	0	0	0		
Gray Scale Of Blue	Blue(0) / Dark	0	0	0	0	0	0	0	0	0	0	0	0	0	0	0	0	0	0	0	0	0	0	0	
	Blue(1)	0	0	0	0	0	0	0	0	0	0	0	0	0	0	0	0	0	0	0	0	0	0	1	
	Blue(2)	0	0	0	0	0	0	0	0	0	0	0	0	0	0	0	0	0	0	0	0	0	1	0	
	⋮	⋮	⋮	⋮	⋮	⋮	⋮	⋮	⋮	⋮	⋮	⋮	⋮	⋮	⋮	⋮	⋮	⋮	⋮	⋮	⋮	⋮	⋮	⋮	
	⋮	⋮	⋮	⋮	⋮	⋮	⋮	⋮	⋮	⋮	⋮	⋮	⋮	⋮	⋮	⋮	⋮	⋮	⋮	⋮	⋮	⋮	⋮	⋮	
	⋮	⋮	⋮	⋮	⋮	⋮	⋮	⋮	⋮	⋮	⋮	⋮	⋮	⋮	⋮	⋮	⋮	⋮	⋮	⋮	⋮	⋮	⋮	⋮	
	Blue(253)	0	0	0	0	0	0	0	0	0	0	0	0	0	0	0	1	1	1	1	1	1	1	0	1
	Blue(254)	0	0	0	0	0	0	0	0	0	0	0	0	0	0	0	1	1	1	1	1	1	1	1	0
Blue(255)	0	0	0	0	0	0	0	0	0	0	0	0	0	0	0	1	1	1	1	1	1	1	1	1	

Note (1) 0: Low Level Voltage, 1: High Level Voltage

4.5 DISPLAY TIMING SPECIFICATIONS

The input signal timing specifications are shown as the following table and timing diagram.

Signal	Item	Symbol	Min.	Typ.	Max.	Unit	Note
LVDS Clock	Frequency	Fc	42.99	58.67	81.25	MHz	-
	Period	Tc	23.26	17.04	12.31	ns	
	Input cycle to cycle jitter	T _{rcj}	-0.02*TC	-	0.02*TC	ns	(1)
	Input Clock to data skew	TLVCCS	-0.02*TC		0.02*TC		(2)
	Spread spectrum modulation range	F _{clk_in_mod}	0.97*FC	-	1.03*TC	MHz	(3)
	Spread spectrum modulation frequency	F _{SSM}	-	-	100	KHz	
Vertical Display Term	Frame Rate	Fr	50	60	75	Hz	
	Total	Tv	905	926	942	Th	Tv=Tvd+Tvb-
	Active Display	Tvd	-	900	-	Th	-
	Blank	Tvb	5	26	42	Th	-
Horizontal Display Term	Total	Th	950	1056	1150	Tc	Th=Thd+Thb
	Active Display	Thd	-	800	-	Tc	-
	Blank	Thb	150	256	350	Tc	-

Note: Because this module is operated by DE only mode, Hsync and Vsync input signals are ignored.

INPUT SIGNAL TIMING DIAGRAM

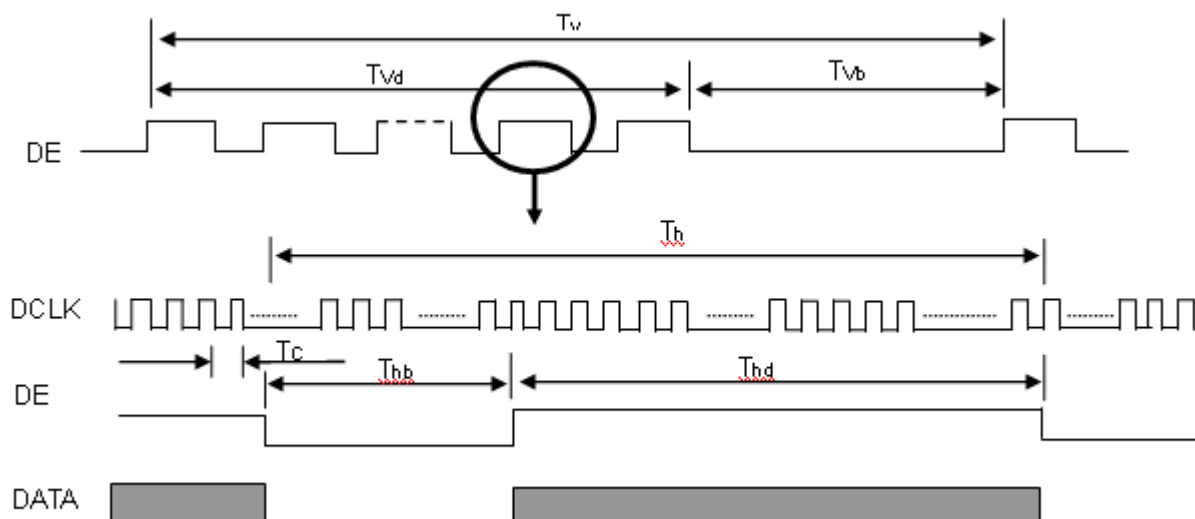

Note (1) The input clock cycle-to-cycle jitter is defined as below figures. $Trcl = |T_1 - T_1'|$

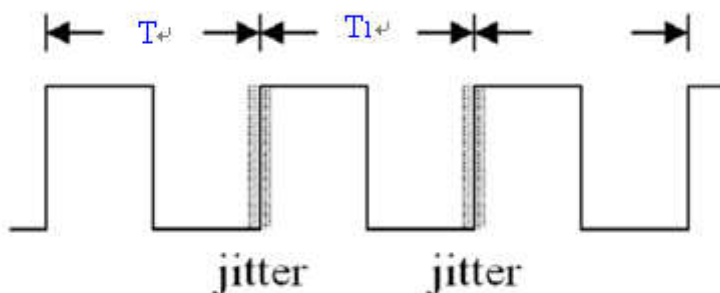

Note (2) Input Clock to data skew is defined as below figures.

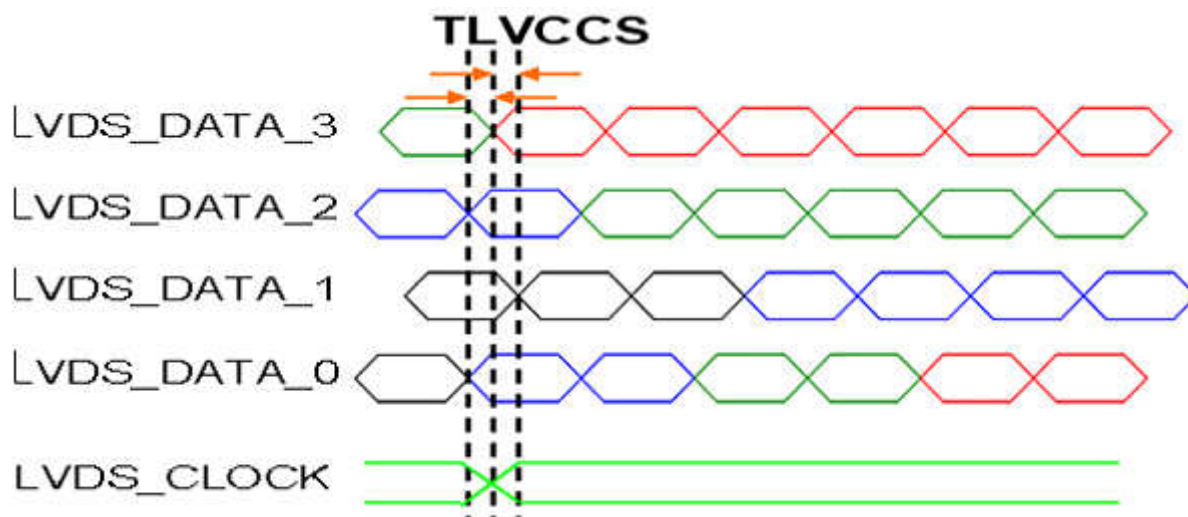

Note (3) The SSCG (Spread spectrum clock generator) is defined as below figures.

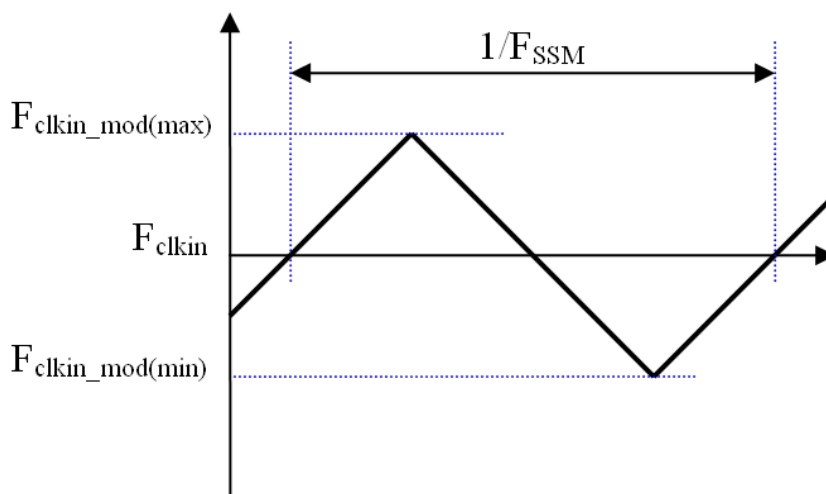

Note(4) The DCLK range at last line of V-blank should be set in 0 to Hdisplay/2

4.6 POWER ON/OFF SEQUENCE

The power sequence specifications are shown as the following table and diagram.

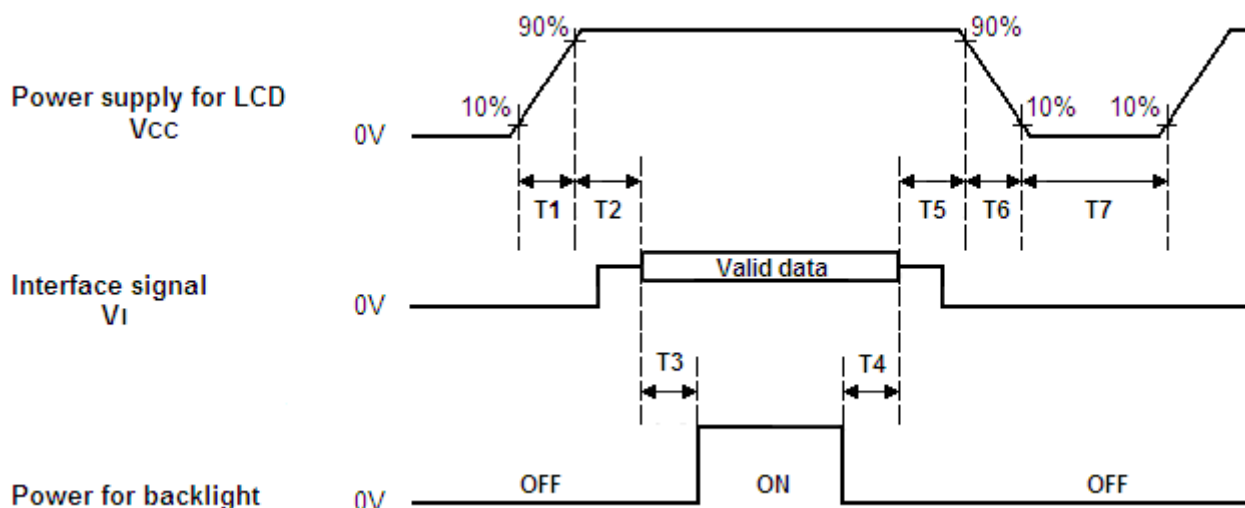

Timing Specifications:

Parameters	Values			Units
	Min	Typ.	Max	
T1	0.5	--	10	ms
T2	0	30	50	ms
T3	200	250	--	ms
T4	100	250	--	ms
T5	0	20	50	ms
T6	0.1	--	100	ms
T7	1000	--	--	ms

Note (1) The supply voltage of the external system for the module input should be the same as the definition of Vcc.

Note (2) When the backlight turns on before the LCD operation of the LCD turns off, the display may momentarily become abnormal screen.

Note (3) In case of VCC = off level, please keep the level of input signals on the low or keep a high impedance.

Note (4) T7 should be measured after the module has been fully discharged between power off and on period.

Note (5) Interface signal shall not be kept at high impedance when the power is on.

Note (6) CMI won't take any responsibility for the products which are damaged by the customers not following the Power Sequence.

Note (7) There might be slight electronic noise when LCD is turned off (even backlight unit is also off). To avoid this symptom, we suggest "Vcc falling timing" to follow "t6 spec".

5. OPTICAL CHARACTERISTICS

5.1 TEST CONDITIONS

Item	Symbol	Value	Unit
Ambient Temperature	Ta	25±2	°C
Ambient Humidity	Ha	50±10	%RH
Supply Voltage	V _{CC}	5	V
Input Signal	According to typical value in "3. ELECTRICAL CHARACTERISTICS"		
LED Light Bar Input Current Per Input Pin	I _{PIN}	65 ± 1.95	mA _{DC}
PWM Duty Ratio	D	100	%
LED Light Bar Test Converter	CMI 27-D041745		

5.2 OPTICAL SPECIFICATIONS

The relative measurement methods of optical characteristics are shown in 5.2. The following items should be measured under the test conditions described in 5.1 and stable environment shown in Note (5).

Item	Symbol	Condition	Min.	Typ.	Max.	Unit	Note					
Color Chromaticity (CIE 1931)	Red	Rx	Typ - 0.03	0.636	Typ + 0.03	-	(1), (5)					
		Ry		0.338								
	Green	Gx		0.311								
		Gy		0.629								
	Blue	Bx		0.159								
		By		0.065								
	White	Wx		0.313								
		Wy		0.329								
	Center Luminance of White (Center of Screen)	L _c						200	250	-	cd/m ²	(4), (5)
	Contrast Ratio	CR						700	1000	-	-	(2), (5)
Response Time	T _R	θ _x =0°, θ _y =0°	-	1.5	2.5	ms	(3)					
	T _F		-	3.5	5.5							
White Variation	W	θ _x =0°, θ _y =0°	75	-	-	%	(5), (6)					
Viewing Angle	Horizontal	θ _x - + θ _x + θ _y - + θ _y + CR ≥ 10	150	170	-	Deg.	(1), (5)					
	Vertical		140	160	-							
Viewing Angle	Horizontal	θ _x - + θ _x + θ _y - + θ _y + CR ≥ 5	160	178	---	Deg.	(1), (5)					
	Vertical		150	170	---							

Note (1) Definition of Viewing Angle (θ_x, θ_y):

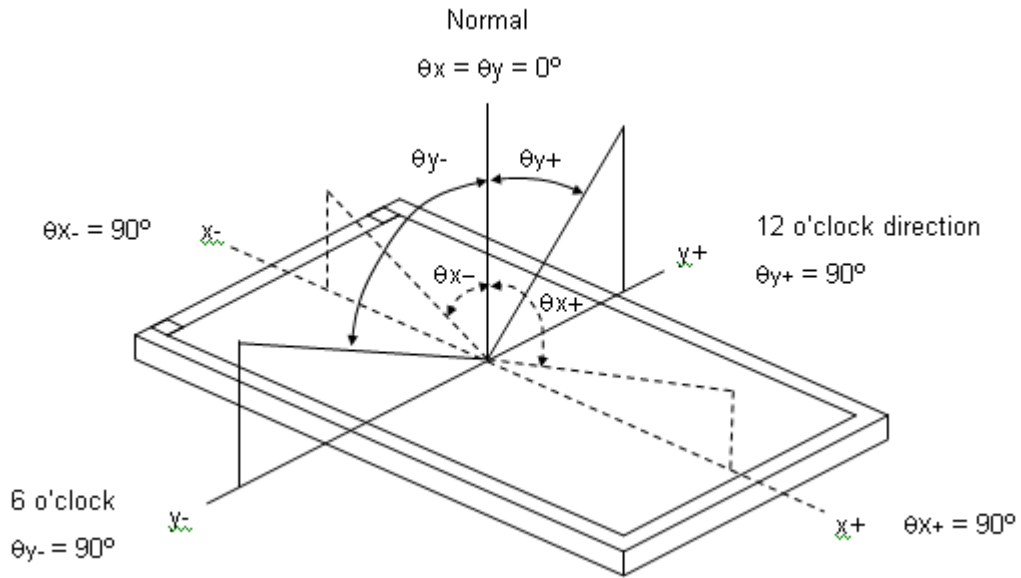

Note (2) Definition of Contrast Ratio (CR):

The contrast ratio can be calculated by the following expression.

$$\text{Contrast Ratio (CR)} = L_{255} / L_0$$

L255: Luminance of gray level 255

L 0: Luminance of gray level 0

$$\text{CR} = \text{CR} (5)$$

CR (X) is corresponding to the Contrast Ratio of the point X at Figure in Note (6).

Note (3) Definition of Response Time (T_R, T_F):

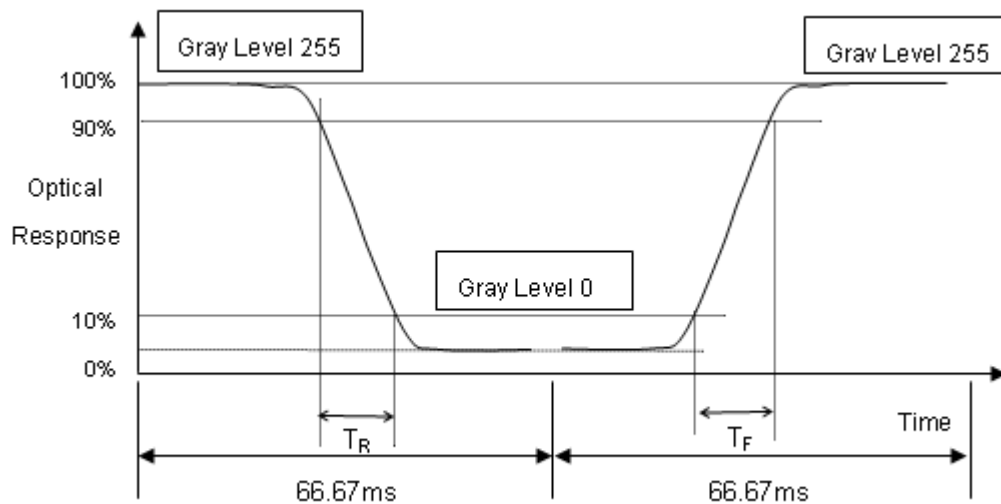

Note (4) Definition of Luminance of White (L_c):

Measure the luminance of gray level 255 at center point

$$L_c = L(5)$$

$L(x)$ is corresponding to the luminance of the point X at Figure in Note (6).

Note (5) Measurement Setup:

The LCD module should be stabilized at given temperature for 40 minutes to avoid abrupt temperature change during measuring. In order to stabilize the luminance, the measurement should be executed after lighting Backlight for 40 minutes in a windless room.

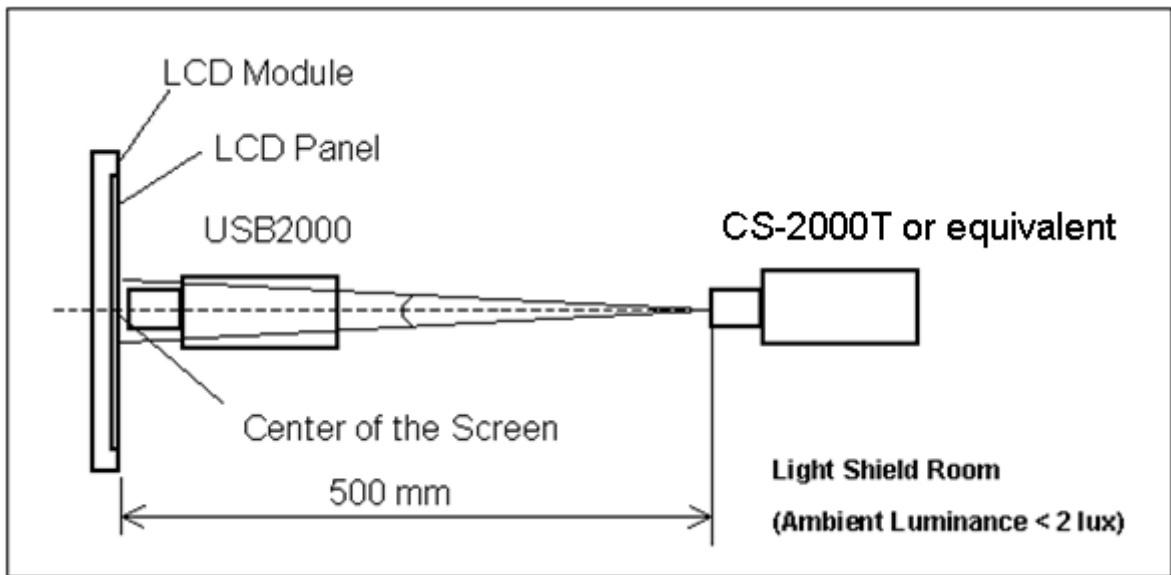

Note (6) Definition of White Variation (δW):

Measure the luminance of gray level 255 at 9 points

$$\delta W = (\text{Minimum } [L(1) \sim L(9)] / \text{Maximum } [L(1) \sim L(9)]) * 100\%$$

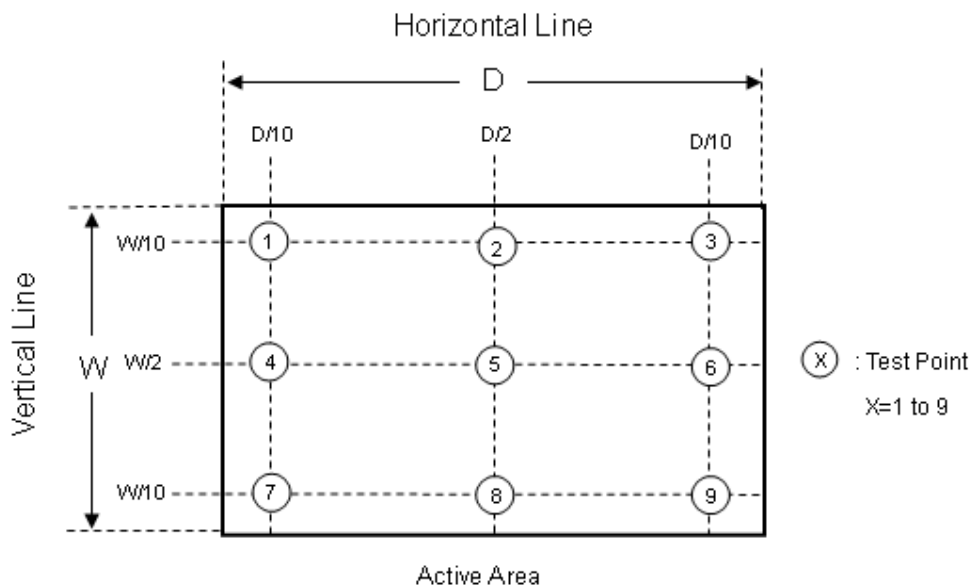

6. RELIABILITY TEST ITEM

Items	Required Condition	Note
Temperature Humidity Bias (THB)	Ta= 50°C , 80%RH, 240hours	
High Temperature Operation (HTO)	Ta= 50°C , 240hours	
Low Temperature Operation (LTO)	Ta= 0°C , 240hours	
High Temperature Storage (HTS)	Ta= 60°C , 240hours	
Low Temperature Storage (LTS)	Ta= -20°C , 240hours	
Vibration Test (Non-operation)	Acceleration: 1.5 G Wave: Sine Frequency: 10 - 300 Hz Sweep: 30 Minutes each Axis (X, Y, Z)	
Shock Test (Non-operation)	Acceleration: 50 G Wave: Half-sine Active Time: 11 ms Direction : ± X, ± Y, ± Z.(one time for each Axis)	
Thermal Shock Test (TST)	-20°C/30min , 60°C / 30min , 100 cycles	
On/Off Test	25°C ,On/10sec , Off /10sec , 30,000 cycles	
ESD (Electro Static Discharge)	Contact Discharge: ± 8KV, 150pF(330Ω)	
	Air Discharge: ± 15KV, 150pF(330Ω)	
Altitude Test	Operation:10,000 ft / 24hours	
	Non-Operation:30,000 ft / 24hours	

Note (1) criteria : Normal display image with no obvious non-uniformity and no line defect.

Note (2) Evaluation should be tested after storage at room temperature for more than two hour

Note (3) At testing Vibration and Shock, the fixture in holding the module has to be hard and rigid enough so that the module would not be twisted or bent by the fixture.

The fixing condition is shown as below:

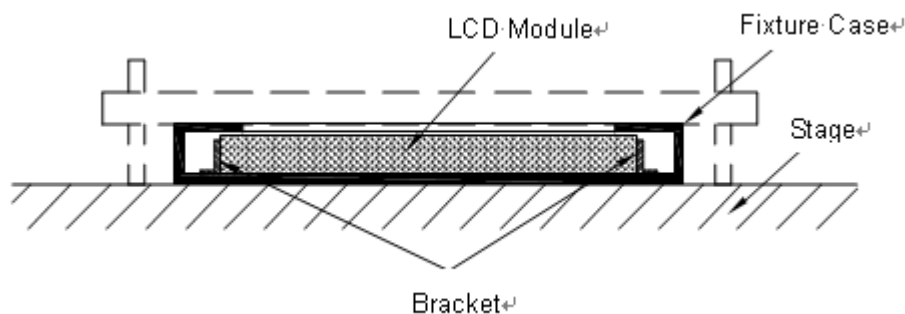

7. MECHANICAL STRENGTH CHARACTERISTICS

7.1 MECHANICAL STRENGTH SPECIFICATIONS

Item	Condition	Force	Unit	Note
Mechanical Strength	128 th Gray Pattern	0.6	Kgf	

7.2 TEST CONDITIONS

Items	Description
Test Condition	1. Ambient Illumination : 10~15 lux 2. Test Pattern : 128 Gray 3. Distance of the judgment : 30cm from the surface of module 4. Viewing angle of the judgment : Front
Gage Information	1. Push pull guage a. Model name : HF-50, maker : ALGOL b. Shape of gage tip - Diameter : 2mm - Thickness : 2mm
Definition of Minimum force	To measure minimum force when operator detects any white spot and light leakage that have occurred while operator presses on back side of module with push pull gage.

7.3 DEFINITION OF TEST POINTS

Measure the minimum force of test points at 128th Gray pattern. The test points at back side of module area is showing as below (except **PCBA**).

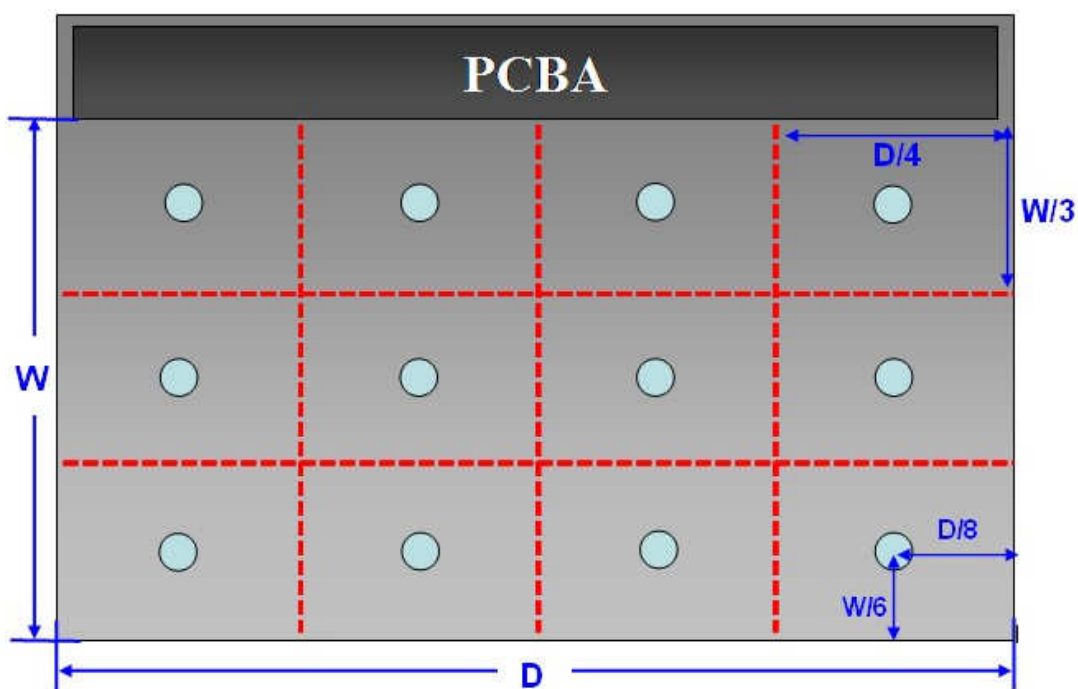

8. PACKING

8.1 PACKING SPECIFICATIONS

- (1) 12 LCD modules / 1 Box
- (2) Box dimensions: 540(L)*380(W)*355(H)mm
- (3) Weight: approximately: 20kg (12 modules per box)

8.2 PACKING METHOD

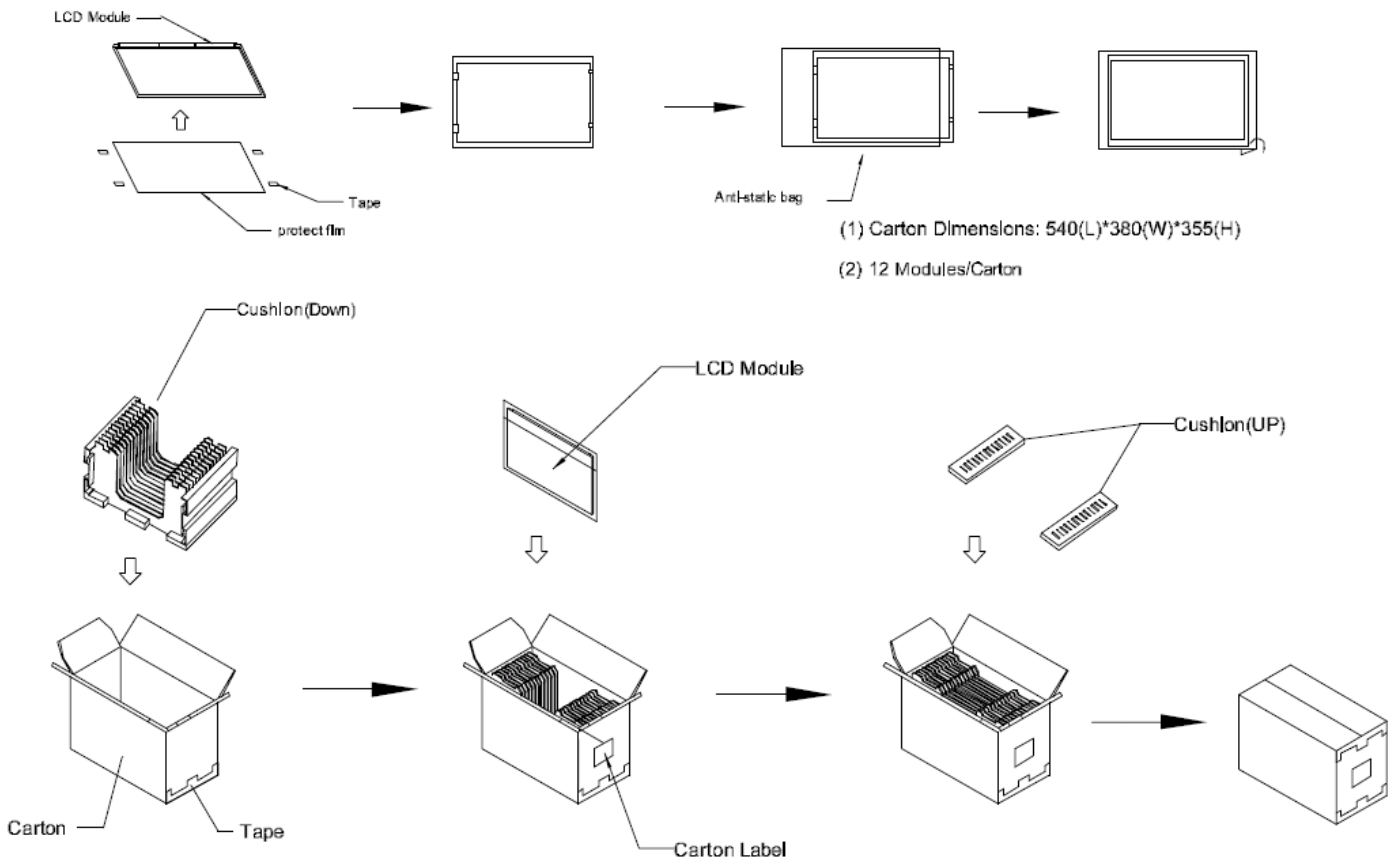

Figure. 8-1 Packing method

8.3 PALLET

For ocean shipping

Sea / Land Transportation (40ft HQ Container)

Sea / Land Transportation (40ft Container)

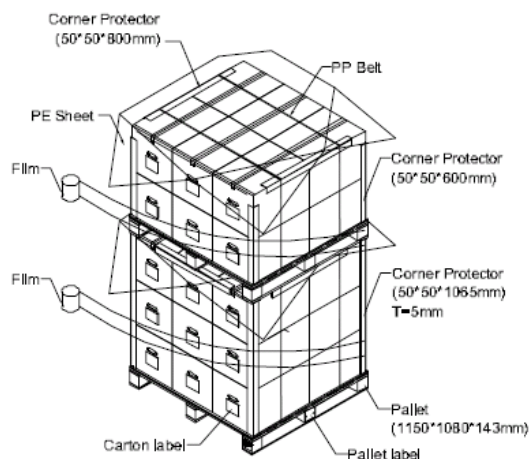
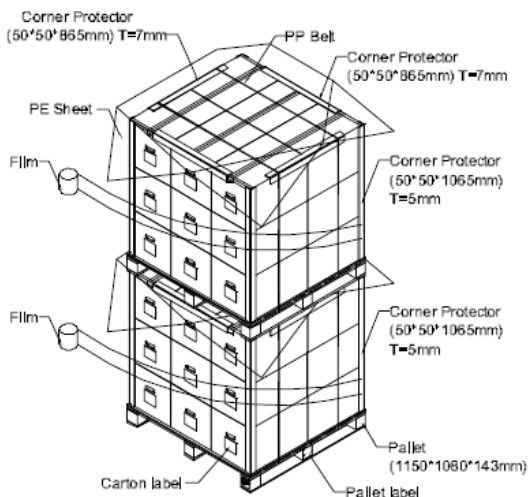

For air transport

Air Transportation

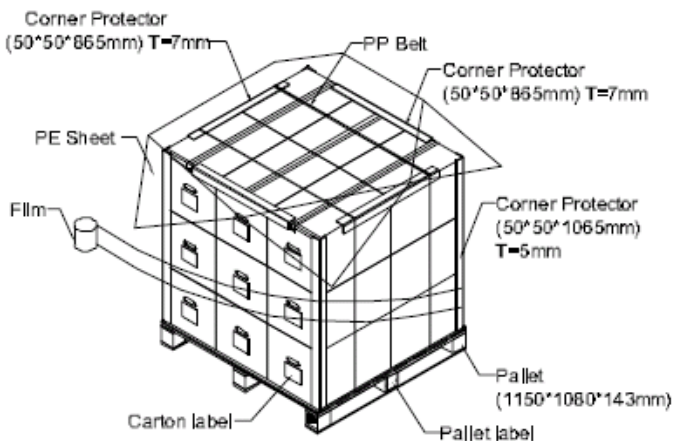
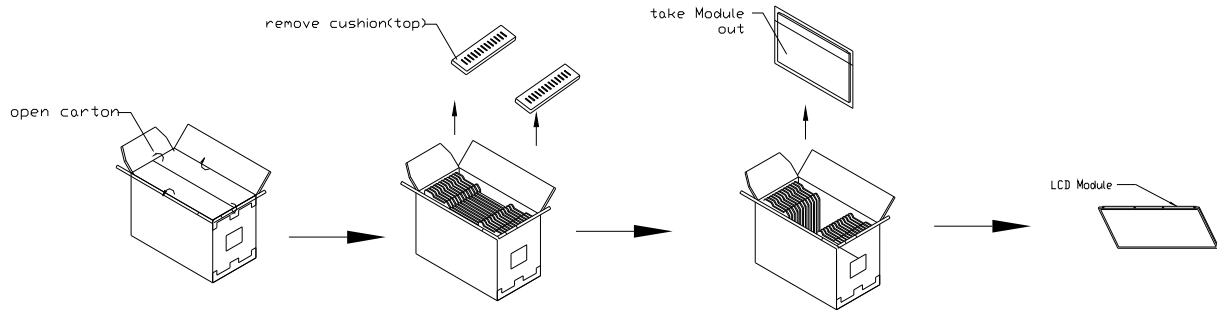

Figure. 8-2 Packing method

8.4 UN-PACKING METHOD



9. CMI MODULE LABEL

The barcode nameplate is pasted on each module as illustration, and its definitions are as following explanation.



(a) Model Name: M195FGE-L20

(b) Revision: Rev. XX, for example: A0, A1... B1, B2... or C1, C2...etc.

(c) CMI barcode definition:

Serial ID: XX-XX-X-XX-YMD-L-NNNN

Code	Meaning	Description
XX	CMI internal use	-
XX	Revision	Cover all the change
X	CMI internal use	-
XX	CMI internal use	-
YMD	Year, month, day	Year: 0~9, 2001=1, 2002=2, 2003=3...2010=0, 2011=1, 2012=2... Month: 1~12=1, 2, 3, ~, 9, A, B, C Day: 1~31=1, 2, 3, ~, 9, A, B, C, ~, W, X, Y, exclude I, O, and U.
L	Product line #	Line 1=1, Line 2=2, Line 3=3, ...
NNNN	Serial number	Manufacturing sequence of product

(d) Customer's barcode definition:

Serial ID: CM-J5E20-X-X-X-XX-L-XX-L-YMD-NNNN

Code	Meaning	Description
CM	Supplier code	CMI=CM
J5E20	Model number	M195FGE-L20= J5E20
X	Revision code	Non ZBD: 1,2,~,8,9 / ZBD: A~Z
X	Source driver IC code	Century=1, CLL=2, Demos=3, Epson=4, Fujitsu=5, Himax=6, Hitachi=7, Hynix=8, LDI=9, Matsushita=A, NEC=B, Novatek=C, OKI=D, Philips=E, Renasas=F, Samsung=G, Sanyo=H, Sharp=I, TI=J, Topro=K, Toshiba=L, Windbond=M, ILITEK=Q, Fiti=Y, None IC =Z
X	Gate driver IC code	
XX	Cell location	Tainan Taiwan=TN, Ningbo China=CN, Hsinchu Taiwan=SC
L	Cell line #	1,2,~,9,A,B,~,Y,Z
XX	Module location	Tainan, Taiwan=TN ; Ningbo China=NP, Nanhai China=NH
L	Module line #	1,2,~,9,A,B,~,Y,Z
YMD	Year, month, day	Year: 0~9, 2001=1, 2002=2, 2003=3...2010=0, 2011=1, 2012=2... Month: 1~12=1, 2, 3, ~, 9, A, B, C Day: 1~31=1, 2, 3, ~, 9, A, B, C, ~, T, U, V
NNNN	Serial number	By LCD supplier

(e) FAB ID(UL Factory ID):

Region	Factory ID
TWCM1	GEMN
NBCM1	LEOO
NBCM2	CANO
NHCM1	CAPG

10. PRECAUTIONS

10.1 ASSEMBLY AND HANDLING PRECAUTIONS

- (1) Do not apply rough force such as bending or twisting to the module during assembly.
- (2) To assemble or install module into user's system can be only in clean working areas. The dust and oil may cause electrical short or worsen the polarizer.
- (3) It's not permitted to have pressure or impulse on the module because the LCD panel and Backlight will be damaged.
- (4) Always follow the correct power sequence when LCD module is connecting and operating. This can prevent damage to the CMOS LSI chips during latch-up.
- (5) Do not pull the I/F connector in or out while the module is operating.
- (6) Do not disassemble the module.
- (7) Use a soft dry cloth without chemicals for cleaning, because the surface of polarizer is very soft and easily scratched.
- (8) It is dangerous that moisture come into or contacted the LCD module, because moisture may damage LCD module when it is operating.
- (9) High temperature or humidity may reduce the performance of module. Please store LCD module within the specified storage conditions.
- (10) When ambient temperature is lower than 10°C may reduce the display quality. For example, the response time will become slowly.

10.2 STORAGE PRECAUTIONS

- (1) Do not leave the module in high temperature, and high humidity for a long time. It is highly recommended to store the module with temperature from 0°C to 35°C and relative humidity of less than 90%
- (2) Do not store the TFT – LCD module in direct sunlight
- (3) The module should be stored in dark place. It is prohibited to apply sunlight or fluorescent light in storing

10.3 OPERATION PRECAUTIONS

- (1) The LCD product should be operated under normal condition.
Normal condition is defined as below :
Temperature : 20±15°C
Humidity: 65±20%
Display pattern : continually changing pattern(Not stationary)

(2) If the product will be used in extreme conditions such as high temperature, high humidity, high altitude, display pattern or operation time etc... It is strongly recommended to contact CMI for application engineering advice. Otherwise, its reliability and function may not be guaranteed.

10.4 SAFETY PRECAUTIONS

- (1) If the liquid crystal material leaks from the panel, it should be kept away from the eyes or mouth. In case of contact with hands, skin or clothes, it has to be washed away thoroughly with soap.
- (2) After the module's end of life, it is not harmful in case of normal operation and storage.

10.5 SAFETY STANDARDS





The LCD module should be certified with safety regulations as follows:

- (1) UL60950-1 or updated standard.
- (2) IEC60950-1 or updated standard.

10.6 OTHER

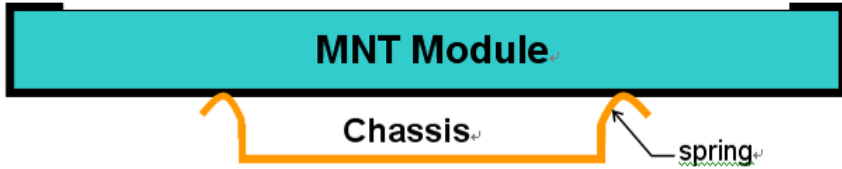
When fixed patterns are displayed for a long time, remnant image is likely to occur.

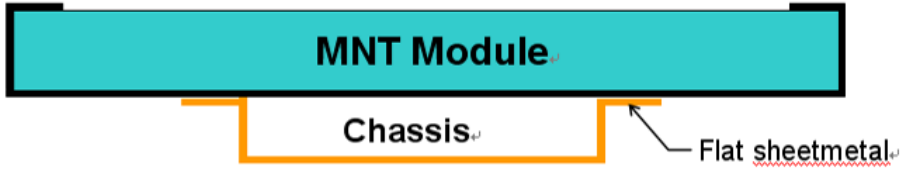
Appendix 1. SYSTEM COVER DESIGN NOTICE

1.	Set Chassis and MNT Module touching Mode
	 <p style="text-align: center;">MNT Module</p> <p style="text-align: center;">Chassis</p> <p style="text-align: right;">spring</p>
	 <p style="text-align: center;">MNT Module</p> <p style="text-align: center;">Chassis</p> <p style="text-align: right;">Flat sheetmetal</p>
	 <p style="text-align: center;">MNT Module</p> <p style="text-align: center;">Chassis</p> <p style="text-align: right;">EMI Shielding Gasket. (Tape/Sponge)</p>
Definition	<p>a) To prevent from abnormal display & white spot after Mechanical test, it is not recommended to used spring type chassis.</p> <p>b) We suggest the contact mode between Chassis and Module rear cover is Tape/Sponge, second is Flat sheetmetal type chassis (Don't interference from flat sheetmeter of chassis to rear cover of Module).</p>

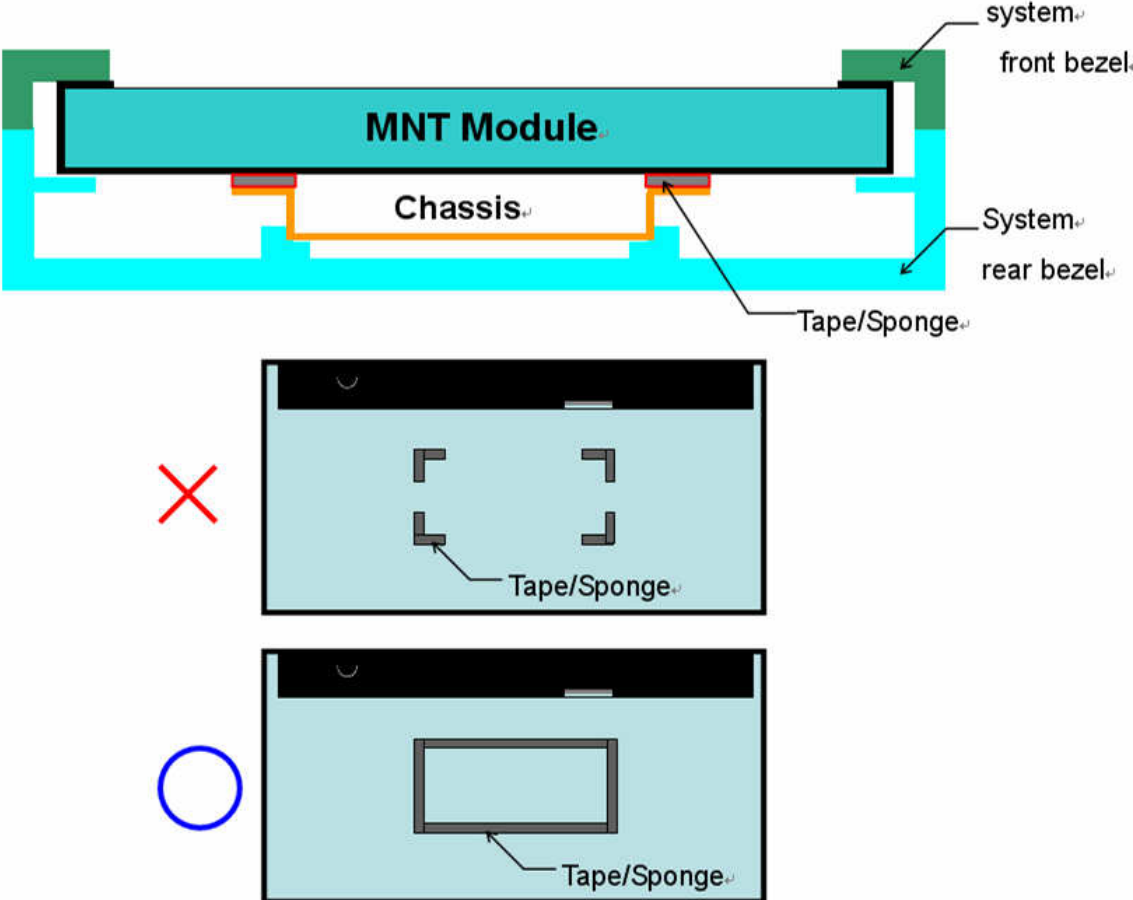
2	Tape/sponge design on system inner surface
	
Definition	<p>a) To prevent from abnormal display & white spot after Mechanical test, We suggest using Tape/Sponge as medium between chassis and Module rear cover could reduce the occurrence of white spot.</p> <p>b) When using the Tape/Sponge, suggest it be lay over between set chassis and module rear cover. it is not recommended to add tape/sponge in separate location. Since each tape/sponge may act as pressure concentration location.</p>

3	System inner surface examination
<p>The diagram illustrates the system inner surface examination. It consists of two parts: a top view and a cross-sectional view. The top view shows a light blue rectangular area representing the system cover, with a red hatched area at the top left and a pink hatched area at the bottom left. The cross-sectional view shows an MNT Module (teal) mounted on a cyan system cover inner surface. Labels include Burr, Chassis, PCB, Step, and System cover inner surface.</p>	
Definition	<p>a). Burr at logo edge, step, protrusion or PCB board will easily cause white spot.</p> <p>b). Keeping flat surface underneath module is recommended.</p> <p>c). The area () on Module PCBA and Light bar connector should keep at least 1mm gap to any structure with System cover inner surface.</p>

REV	EC NUMBER	DESCRIPTION	DATE
1	XXXXXX	XXXXXXXX	xxxx/xx/xx

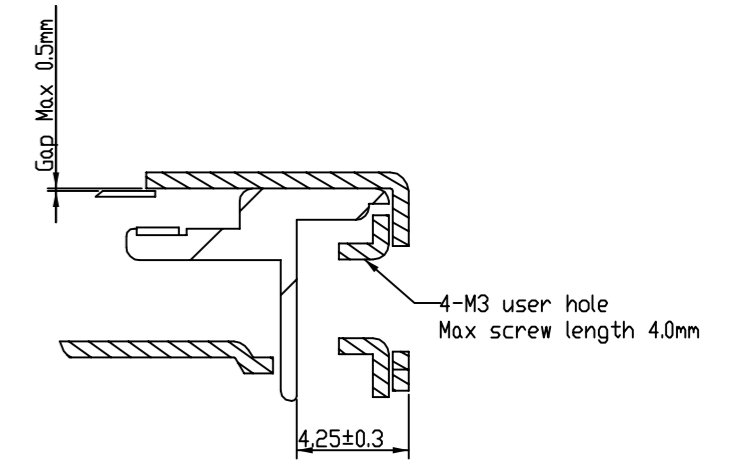
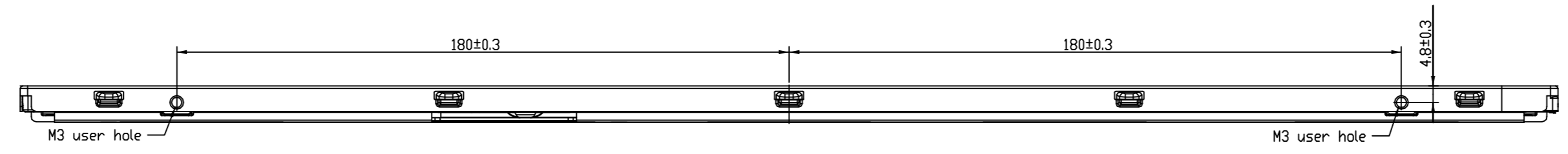
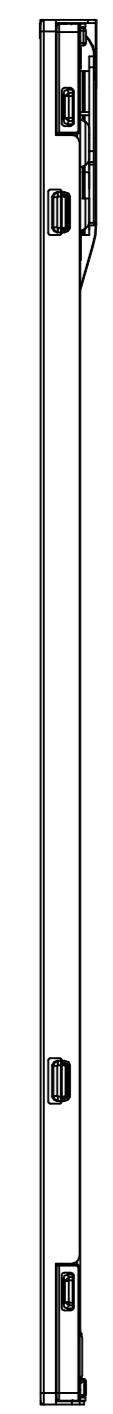
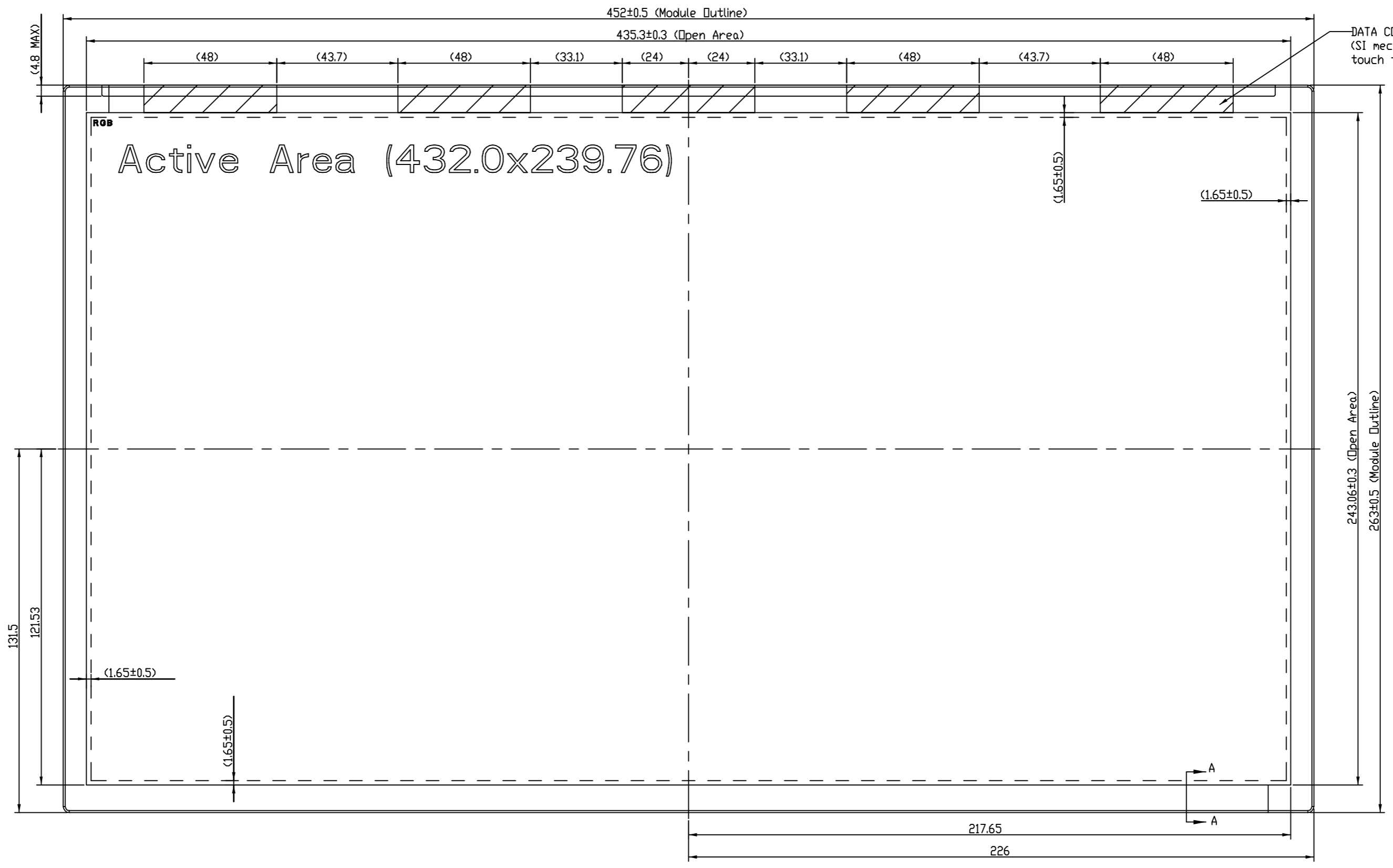
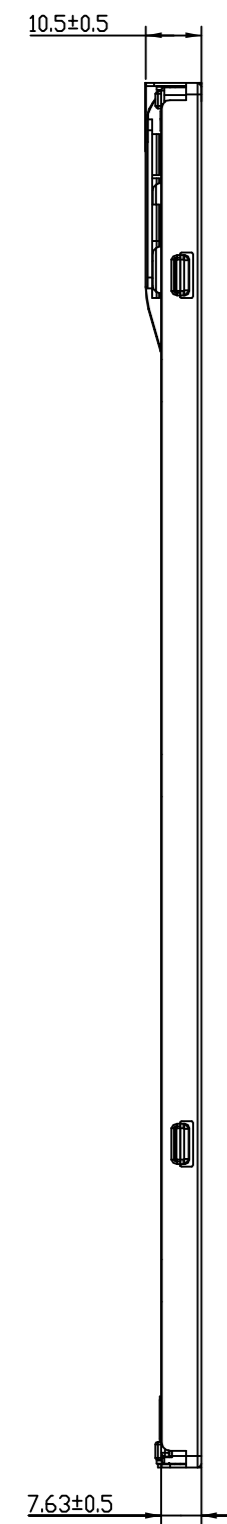
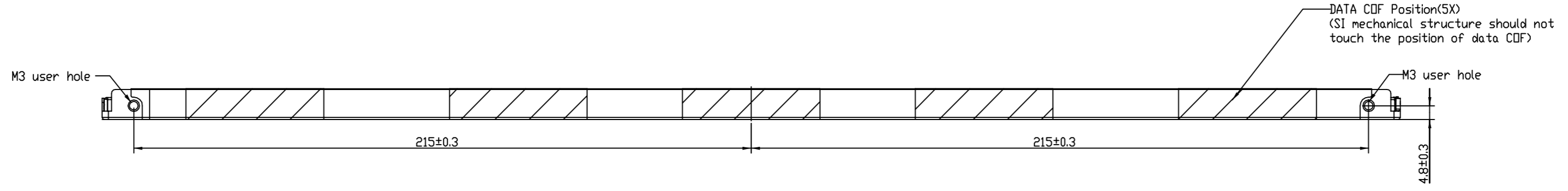

SECTION A-A
SCALE 5

NOTE:
 1.THE DIMENSION EXCLUDES DEFORMATION
 2.TOLERANCE WITHOUT NOTICED TO BE ±0.5MM
 3.TORQUE OF M3 USER HOLE SHOULD BE WITHIN 5 kgf-cm AND JUST RESCREW 10 TIMES
 4.DISPLAY AREA POSITION TOLERANCE:IA-BK=1 & IC-DK=1
 5.THE CDF AREA IS WEAK & SENSIVE PLEASE DON'T PRESS THE CDF AREA.

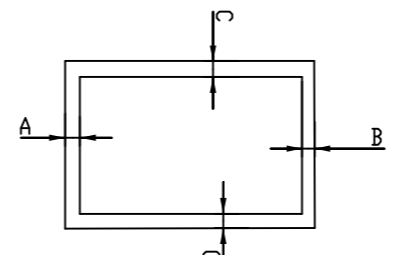

NO.	DATE	SCALE	UNIT	REVISION
1	2010/12/02	1:1	mm	
2				
3				
4				
5				
6				
7				
8				
9				
10				
11				
12				
13				
14				
15				
16				
17				
18				
19				
20				

REV	EC NUMBER	DESCRIPTION	DATE
△	XXXXXXX	XXXXXXXX	xxxx/xx/xx

DATA CDF Position(SX)
(SI mechanical structure should not touch the position of data CDF)

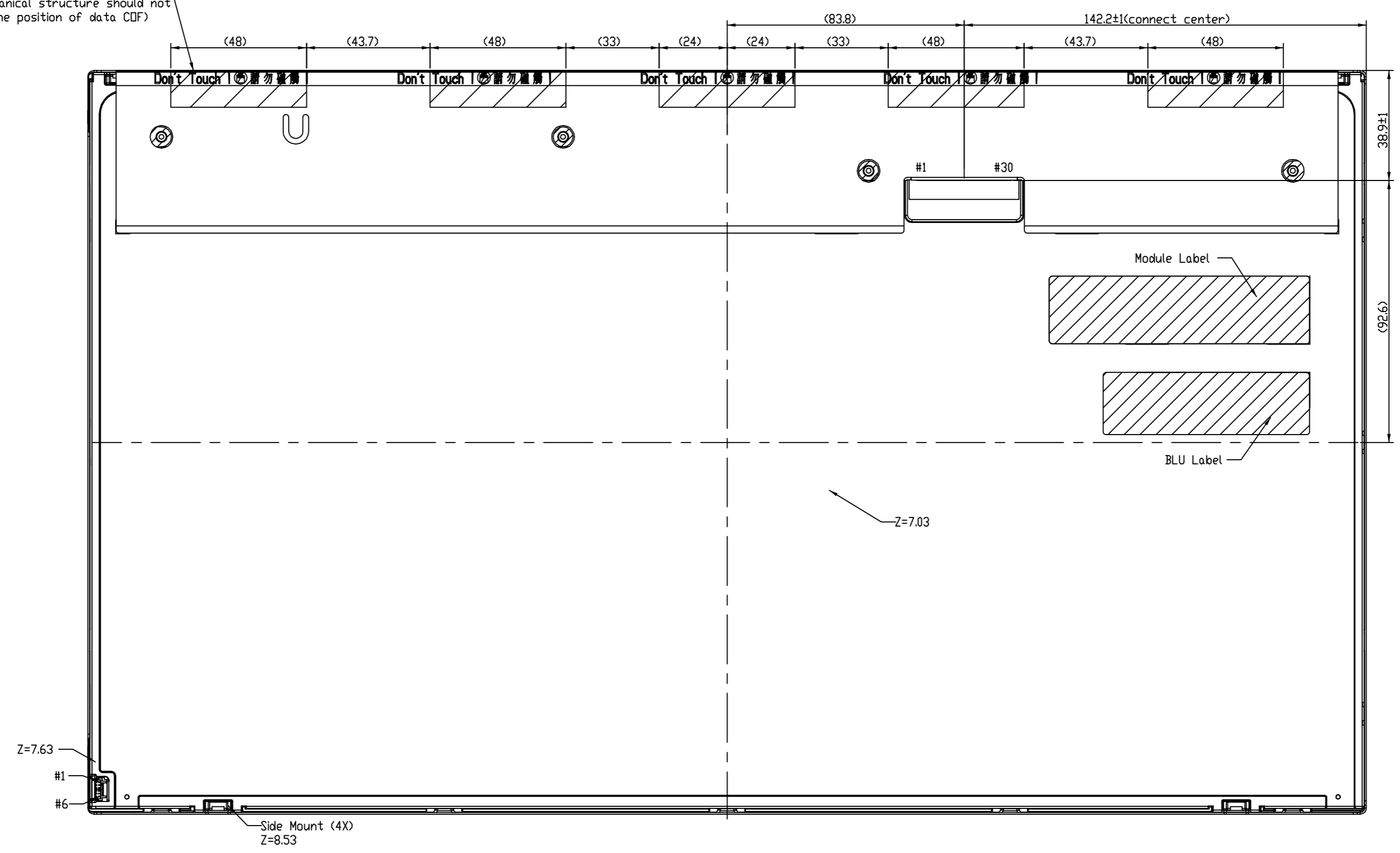

NOTE:
1.THE DIMENSION EXCLUDES DEFORMATION
2.TOLERANCE WITHOUT NOTICED TO BE ±0.5MM
3.TORQUE OF M3 USER HDLE SHOULD BE WITHIN 5 kgf-cm AND JUST RESCREW 10 TIMES
4.THE CDF AREA IS WEAK & SENSIVE PLEASE DON'T PRESS THE CDF AREA.

REV	EC NUMBER	DESCRIPTION	DATE	SCALE	UNIT	MARK
△	XXXXXXX	XXXXXXXX	xxxx/xx/xx	1:1	mm	

NO.	DESCRIPTION	DATE	SCALE	UNIT	MARK
1	DESIGNED	2019/12/12	1:1	mm	
2	CHECKED				
3	APPROVED				

NO.	DESCRIPTION	DATE	SCALE	UNIT	MARK
1	DESIGNED	2019/12/12	1:1	mm	
2	CHECKED				
3	APPROVED				

NO.	DESCRIPTION	DATE	SCALE	UNIT	MARK
1	DESIGNED	2019/12/12	1:1	mm	
2	CHECKED				
3	APPROVED				

INNOLUX
M195FGE-L20