



SPECIFICATION



P1850FHF1MB01

18.5" - FHD – LVDS

Version: 2.3

Date: 05.07.2023

Note: This specification is subject to change without prior notice

CONTENTS

1. SUMMARY	1
1.1 General Description.....	1
1.2 Features.....	1
2. GENERAL SPECIFICATIONS	2
3. INPUT / OUTPUT TERMINALS	3
3.1 CN1 Pin assignment (LCD Interface).....	3
3.2 CN2 Pin assignment (Back Light).....	4
4. ABSOLUTE MAXIMUM RATINGS	5
5. ELECTRICAL CHARACTERISTICS	6
5.1 DC Characteristics for Panel Driving.....	6
5.2 DC Characteristics for Backlight Driving.....	6
5.3 Recommended Power ON/OFF Sequence.....	8
5.4 LCD Module Block Diagram.....	9
6. INTERFACE TIMING CHARACTERISTICS	10
6.1 Data Input Timing Parameter Setting.....	10
6.2 DE Mode Timing Diagram.....	10
7. OPTICAL CHARACTERISTICS	11
8. RELIABILITY TEST	14
9. MECHANICAL DRAWING	15
10. PACKING INSTRUCTION	16
11. PRECAUTIONS FOR USE OF LCD MODULES	17
11.1 Handling Precautions.....	17
11.2 Storage precautions.....	17
11.3 Transportation Precautions.....	17
11.4 Screen saver Precautions.....	17
11.5 Safety Precautions.....	17

1. Summary

1.1 General Description

This is a 18.5 inch a-Si TFT-LCD module with Normal- Black technology. It is composed of a TFT-LCD panel, a driver circuit, PCB, and a LED backlight unit.

1.2 Features

- Ultra-wide viewing angle
- High resolution
- Interface: LVDS

- Acquisition product for UL62368-1/CSA C22.2 No.62368-1-03 (File number: E250878)
- Compliant with the European RoHS Directive (2011/65/EU) and Delegated Directive (2015/863/EU, Amending Annex II of 2011/65/EU)

2. General Specifications

	Feature	Spec	Unit
Display Spec	Size	18.5 inches	
	Resolution	1920(RGB)x1080	
	Pixel Pitch	0.213x0.213	mm
	TFT Active Area	408.96 x 230.04	mm
	Technology Type	a-Si	
	Pixel Configuration	R.G.B Vertical Stripe	
	Display Mode	SFT, Normally Black	
	Surface Treatment	Anti-Glare	
	Viewing Direction	-	
	Gray Scale Inversion Direction	-	
Mechanical Characteristics	LCM (W x H x D)	430.4 x 254.6 x13.5	mm
	Weight	1550	g
Optical Characteristics	Luminance	400	cd/m ²
	Contrast Ratio	1000:1	
	NTSC	72	%
	Viewing Angle	88/88/88/88	degree
Electrical Characteristics	Interface	LVDS 2port 8 bits	
	Color Depth	16.7 Million	color
	Power Consumption	LCD:2000; Backlight:13200	mW
Touch Spec	Type	With out	
	Lamination Type	-	
	Interface	-	

Table 2.1 General TFT Specifications

3. Input / Output Terminals

3.1 CN1 Pin assignment (LCD Interface)

Connector Information	
LCD Module connector	MDF76KBW-30S-1H(55) (HIROSE)
Matching connector	MDF76-30P-1C (HIROSE)

Table 3.1.1 Connector information

No	Symbol	I/O	Description	Comment
1	DA0-	I	Odd pixel data 0	
2	DA0+	I		
3	DA1-	I	Odd pixel data 1	
4	DA1+	I		
5	DA2-	I	Odd pixel data 2	
6	DA2+	I		
7	GND	P	Ground	
8	CLKA-	I	Odd pixel clock	
9	CLKA+	I		
10	DA3-	I	Odd pixel data 3	
11	DA3+	I		
12	DB0-	I	Even pixel data 0	
13	DB0+	I		
14	GND	P	Ground	
15	DB1-	I	Even pixel data 1	
16	DB1+	I		
17	GND	P	Ground	
18	DB2-	I	Even pixel data 2	
19	DB2+	I		
20	CLKB-	I	Even pixel clock	
21	CLKB+	I		
22	DB3-	I	Even pixel data 3	
23	DB3+	I		
24	GND	P	Ground	
25	GND	P	Ground	
26	GND	P	Ground	
27	GND	P	Ground	
28	VCC	P	Power supply	
29		P		
30		P		

Table 3.1.2 Pin Assignment for LCD Interface

Note1: I/O definition: I---Input, O---Output, P---Power/Ground, N---No connection

Note2: All of the GND pins should be connected to the system ground.

Note3: This LCD module supports DE mode.

3.2 CN2 Pin assignment (Back Light)

Connector Information	
LCD Module connector	DF19L-14P-1H(52) (HIROSE)
Matching connector	DF19-14S-1C (HIROSE)

Table 3.2.1 Connector information

No	Symbol	I/O	Description	Description
1	VDD	P	Power supply	Note3
2	VDD	P		
3	VDD	P		
4	VDD	P		
5	VDD	P		
6	GND	P	LED driver ground	Note3
7	GND	P		
8	GND	P		
9	GND	P		
10	GND	P		
11	RSVD	N	Keep this pin open.	-
12	BRTC	I	Backlight ON/OFF control	High or Open:
13	PWM	I	Luminance control	PWM dimming
14	GND	P	LED driver ground	Note1

Table 3.2.2 Pin Assignment for Back Light Interface

Note1: I/O definition: I---Input, O---Output, P---Power/Ground, N---No connection

Note2: All of the GND pins should be connected to the system ground.

Note3: All VDD and GND terminals should be used without any non-connected lines.

4. Absolute Maximum Ratings

GND=0V

Parameter		Symbol	Rating	Unit	Remarks
Power supply voltage	LCD panel signal processing board	VCC	-0.3to +6.5	V	Ta= 25°C
	LED driver	VDD	-0.3to +15		
Input voltage for signals	Display signals Note1	VD	-0.3to +3.2	V	
	Function signal for LED driver	PWM	-0.3to +5.5	V	
		BRTC	-0.3to +5.5	V	
Storage temperature		Tst	-30 to +80	°C	
Operating temperature	Front surface	TopF	-20 to +70	°C	Note2
	Rear surface	TopR	-20 to +70	°C	Note3
Relative humidity Note4		RH	≤ 95	%	Ta ≤ 40°C
			≤ 85	%	40°C < Ta ≤ 50°C
			≤ 55	%	50°C < Ta ≤ 60°C
			≤ 36	%	60°C < Ta ≤ 70°C
Absolute humidity Note4		AH	≤ 70 Note5	g/m ³	Ta = 70°C

Table 4.1 Absolute Maximum Ratings

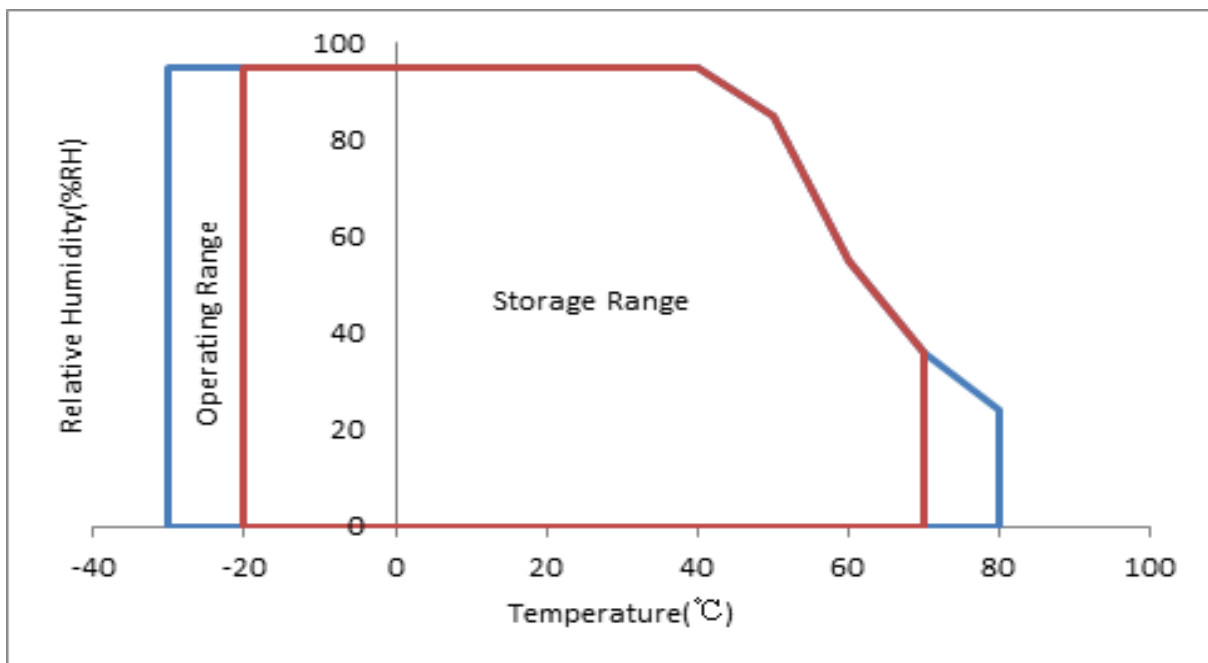

Table 4.2 Absolute Maximum Ratings chart

- Note1: DA0+/-, DA1+/-, DA2+/-, DA3+/- ,CLKA+/-, DB0+/-, DB1+/-, DB2+/-, DB3+/-, CLKB+/-
- Note2: Measured at LCD panel surface (including self-heat)
- Note3: Measured at LCD module's rear shield surface (including self-heat)
- Note4: No condensation
- Note5: Water amount at Ta= 70°C and RH= 36%

5. Electrical Characteristics

5.1 DC Characteristics for Panel Driving

(Ta= 25°C)

Parameter	Symbol	min.	typ.	max.	Unit	Remarks	
Power supply voltage	VCC	4.5	5.0	5.5	V	-	
Power supply current	ICC	-	400 Note1	680 Note2	mA	at VCC= 5V	
Permissible ripple voltage	VRPC	-	-	100	mVp-p	for VCC	
Differential input threshold voltage	High	VTH	-	-	+100	mV	at VCM= 1.2V
	Low	VTL	-100	-	-	mV	
Input Differential Voltage	VID	100	400	600	mV	-	
Differential Input Common Mode Voltage	VCM	0.7	1.2	1.6	V	-	
Terminating resistance	RT	-	100	-	Ω	-	

Table 5.1.1 Operating Voltages

Note1: Indicated the subsequent version may be updated.

5.2 DC Characteristics for Backlight Driving

Parameter	Symbol	min.	typ.	max.	Unit	Remarks	
Power supply voltage	VDD	(10.8)	(12.0)	(13.2)	V	Note1	
Power supply current	IDD	-	(1,100)	(1,350) Note2	mA	at VDD= 12.0V Note3	
Permissible ripple voltage	VRPD	-	-	200	mVp-p	for VDD Note3, Note4, Note5	
Input voltage for PWM signal	High	VDFH1	2.0	-	5.0	V	-
	Low	VDFL1	0	-	0.4		
Input voltage for BRTC signal	High	VDFH2	2.0	-	5.0		
	Low	VDFL2	0	-	0.8		
Input current for PWM signal	High	IBCH1	-	-	+300	μA	-
	Low	IBCL1	-300	-	-		
Input current for BRTC signal	High	IBCH2	-	-	+300		
	Low	IBCL2	-300	-	-		
PWM frequency	f _{PWM}	200	-	1k	Hz	Note6, Note8	
PWM duty ratio	DR _{PWM}	1	-	100	%	Note7, Note9, Note10	
PWM pulse width	t _{PWH}	5	-	-	μs	Note9, Note10	
LED life time	Hr	-	50000	-	Hour	Note 11	
LED supply voltage	VF	2.7	3.1	3.5	V		
LED supply current	IF		70		mA/ch	6ch*9pcs	

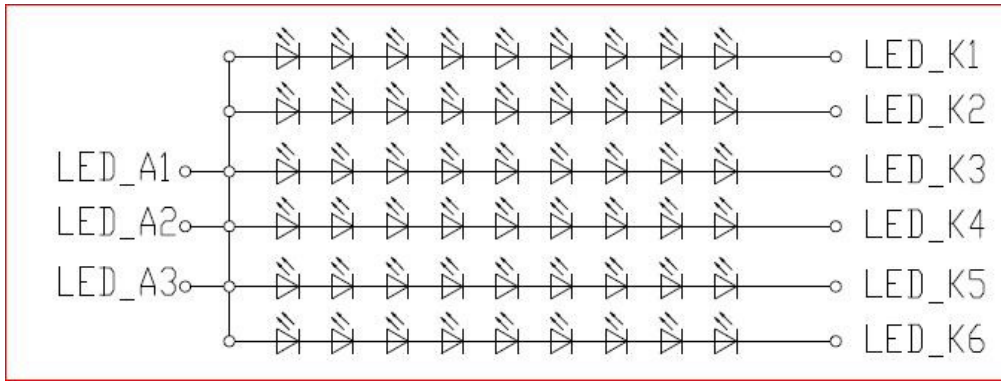

Table 5.2.1 LED Backlight Characteristics

Note1: I_F is defined for each channel.

Note2: Optical performance should be evaluated at $T_a=25^\circ\text{C}$ only.

Note3: If LED is driven by high current, high ambient temperature & humidity condition, The life time of LED will be reduced.

Note4: Operating life means brightness goes down to 50% of initial brightness. Typical operating life time is estimated data.

5.3 Recommended Power ON/OFF Sequence

Power ON Sequence

Item	Symbol	Min	Typ	Max	Unit	Remark
VCC on to VCC stable	t1	0.05	-	50	ms	
VCC off to next VCC on	t2	50	-	-	ms	
VCC stable to Signal stable	t3	0	-	35	ms	
Signal off to VCC off	t4	0	-	35	ms	
Signal stable to BL on	t5	200	-	-	ms	

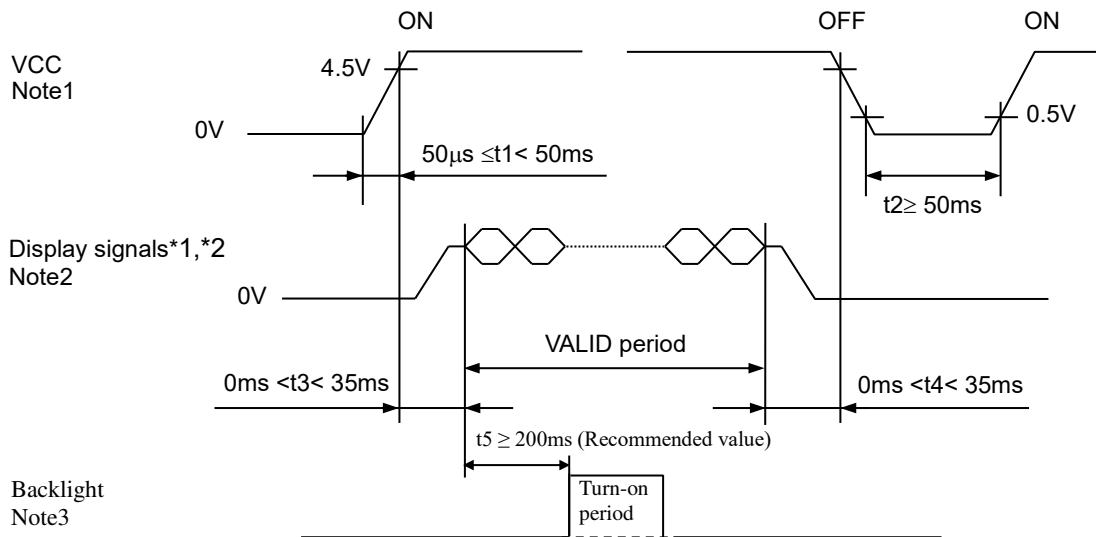

LED driver

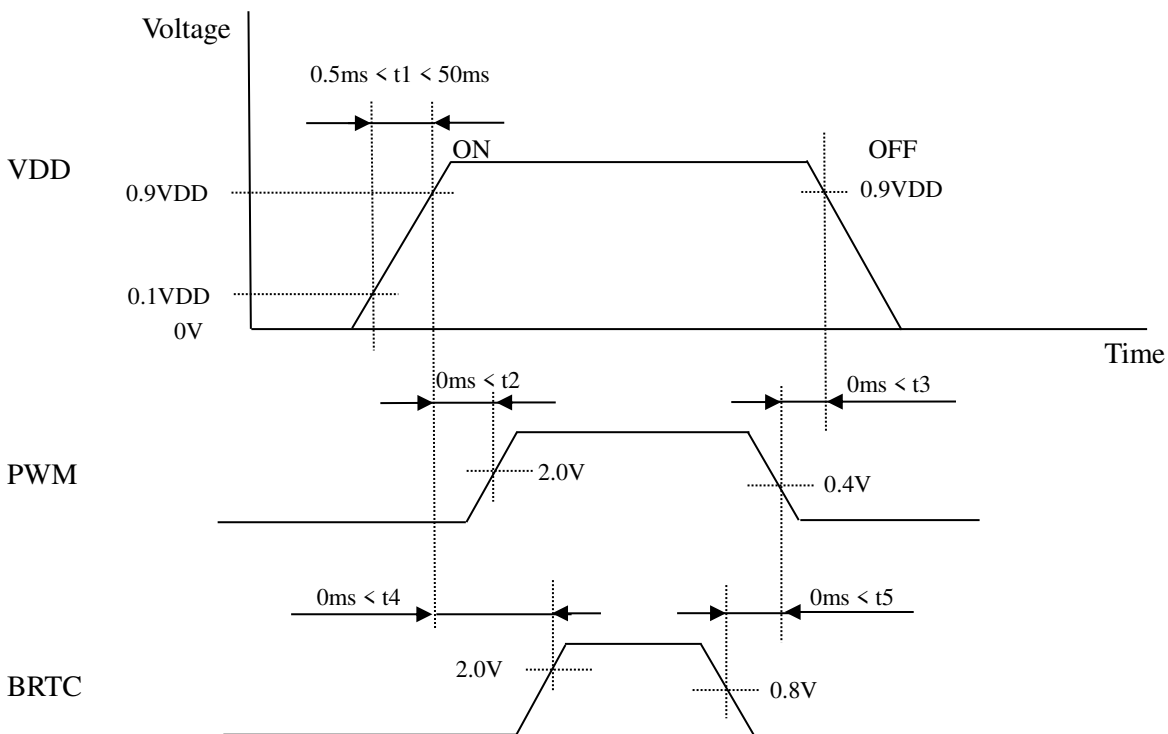

Note1: T1 < T2.

Note2: The low level of these signals and analog powers are GND level.

Note3: All of the power and signals should be kept at GND level before power on. If there are residual voltages on them, the LCD might not work properly.

Note4: The power on/off sequence is the first version. It will be updated when the design is fixed.

Note5: BL is the voltage applied to backlight. Keep it turned off until the display has stabilized.

5.4 LCD Module Block Diagram

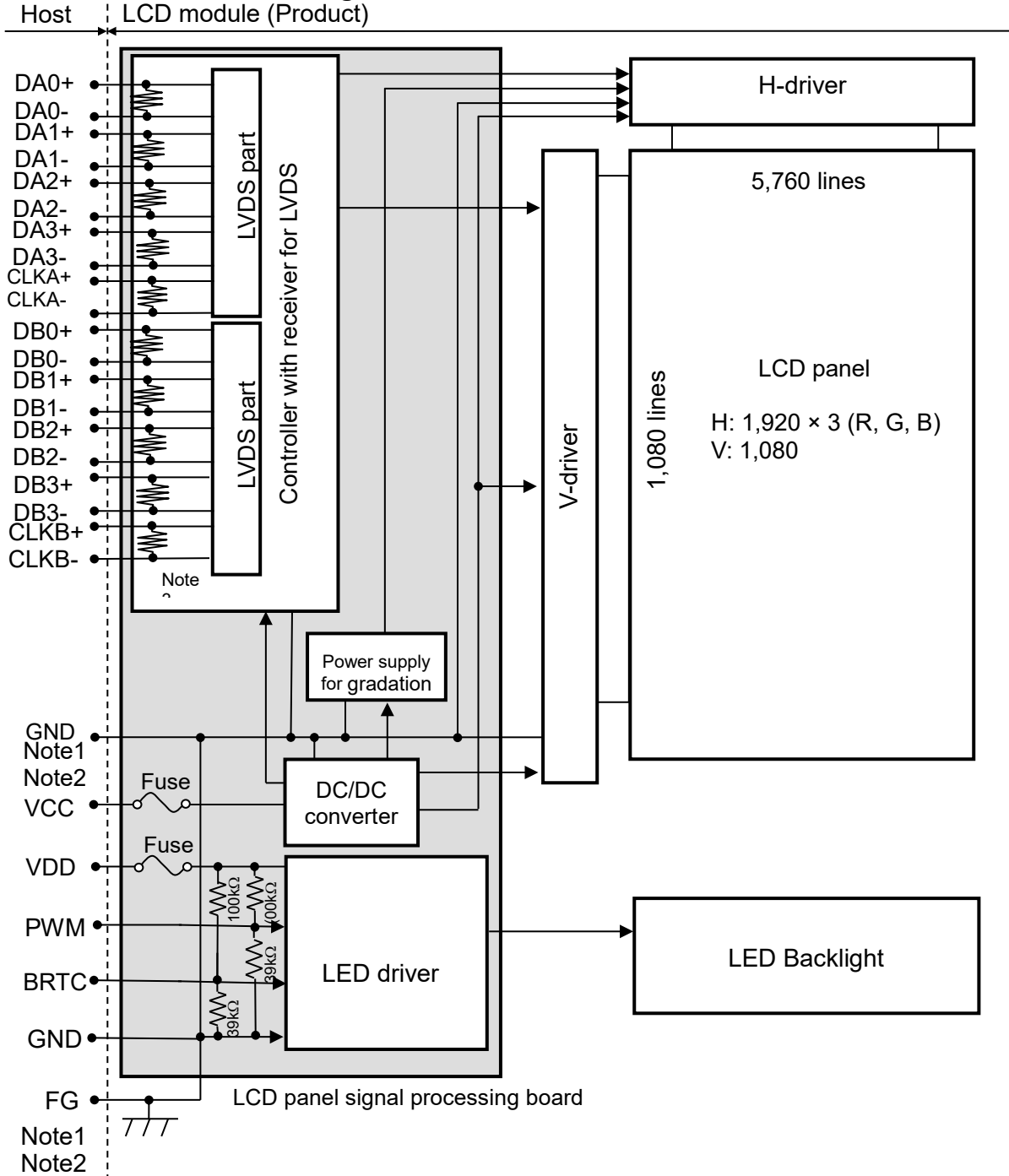

Note1: Relation between GND (Signal ground and LED driver ground) and FG (Frame ground) in the LCD module is as follows.

GND- FG	Connected
---------	-----------

Note2: GND and FG must be connected to customer equipment's ground, and it is recommended that these grounds to be connected together in customer equipment.

Note3: Each pair of the LVDS signal has a 100Ω terminating resistance.

Figure 5.5.1 LCD Module Block Diagram

6. Interface Timing Characteristics

6.1 Data Input Timing Parameter Setting

Parameter		Symbol	min.	typ.	max.	Unit	Remarks	
CLK	Frequency	1/tc	65.0	74.175	81.5	MHz	13.48ns (typ.)	
	Duty ratio	-				-	-	
	Rise time, Fall time	-				ns	-	
DE	Horizontal	Cycle	th	13.19	14.83	16.53	μ s	67.43kHz (typ.)
		Display period	thd	1,075	1,100	-	CLK	
	Vertical (One frame)	Cycle	tv	15.39	16.68	18.18	ms	59.94Hz (typ.)
		Display period	tvd	1,100	1,125	-	H	
	CLK-DE	Setup time	-				ns	-
		Hold time	-				ns	
	Rise time, Fall time		-				ns	

Table 6.1.1 Data Input Timing Parameters

6.2 DE Mode Timing Diagram

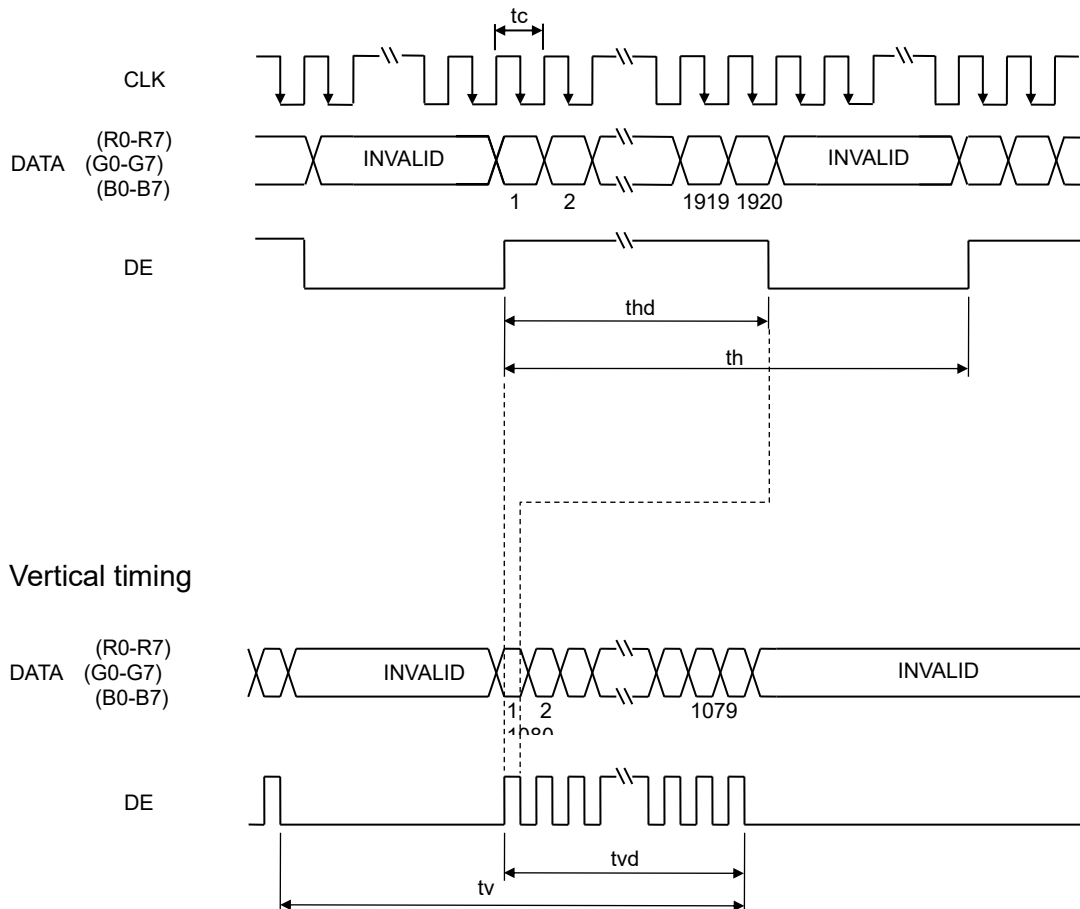

Figure 6.2.1 Data Input Timing Diagram Under DE Mode

7. Optical Characteristics

Item	Symbol	Condition	Min	Typ	Max	Unit	Remark
View Angles	θT	$CR \geq 10$	70	88		degree	Note2,3
	θB		70	88			
	θL		70	88			
	θR		70	88			
Contrast Ratio	CR	$\theta=0^\circ$	600	1000			Note 3
Response Time	T_{ON}	25°C	-	25	40	ms	Note 4
	T_{OFF}						
Chromaticity	White	Backlight is on	x	(0.254)	(0.304)	(0.354)	Note 1,5
			y	(0.291)	(0.341)	(0.391)	
	Red		x	(0.592)	(0.642)	(0.692)	Note 1,5
			y	(0.290)	(0.340)	(0.390)	
	Green		x	(0.236)	(0.286)	(0.336)	Note 1,5
			y	(0.586)	(0.636)	(0.686)	
	Blue		x	(0.099)	(0.149)	(0.199)	Note 1,5
			y	(0.024)	(0.074)	(0.124)	
Uniformity	U	-	72	80	-	%	Note 6
NTSC	-	-	65	72	-	%	Note 5
Luminance	L		280	400	-	cd/m ²	Note 7

Table 7.1 Optical Parameters

Test Conditions:

1. $I_F = 70$ mA, and the ambient temperature is 25°C.
2. The test systems refer to Note1 and Note2.

Note1: Definition of optical measurement system.

The optical characteristics should be measured in dark room. After 5 Minutes operation, the optical characteristics are measured at the center point of the LCD screen.

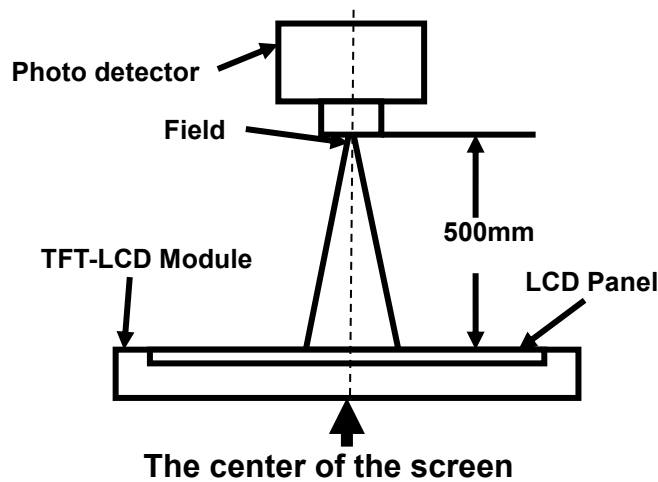

Fig1.Measurement Set Up

Note2: Definition of viewing angle range and measurement system. Viewing angle is measured at the center point of the LCD .

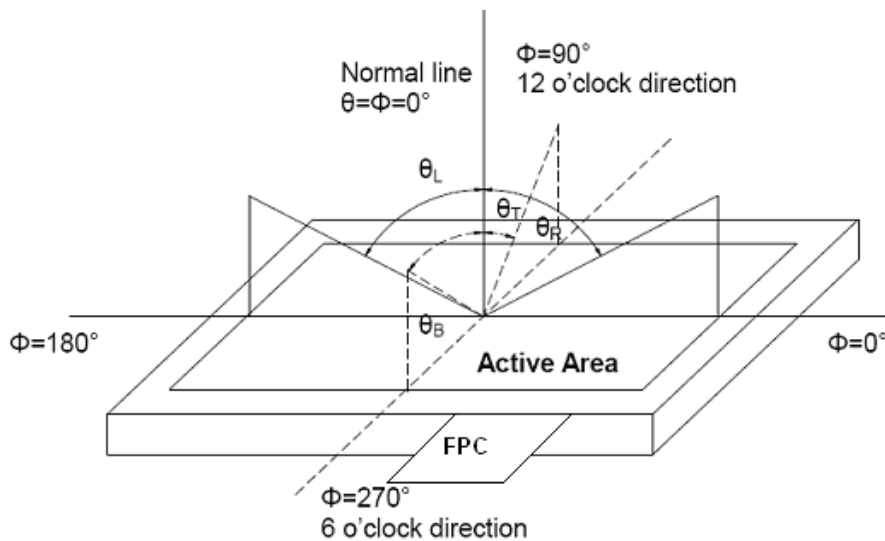

Fig2. Measurement viewing angle

Note3: Definition of contrast ratio

$$\text{Contrast ratio (CR)} = \frac{\text{Luminance measured when LCD is on the "White" state}}{\text{Luminance measured when LCD is on the "Black" state}}$$

Note4: Definition of Response time

For TN LCM, the response time is defined as the LCD optical switching time interval between "White" state and "Black" state. Rise time (T_r) is the time between photo detector output intensity changed from 90% to 10%. And fall time (T_f) is the time between photo detector output intensity changed from 10% to 90%.

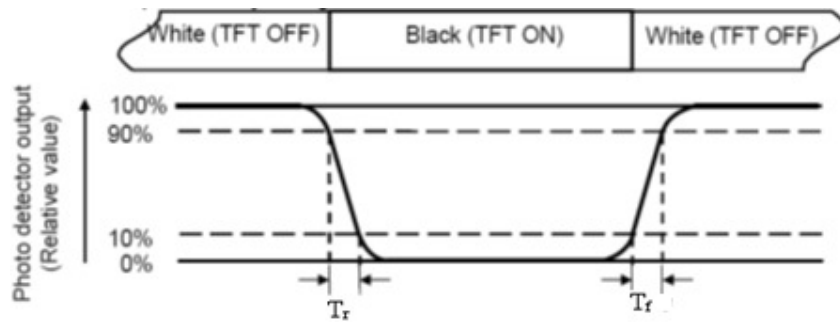

Fig3. Response Time Testing(TN)

For SFT LCM, the response time is defined as the LCD optical switching time interval between “White” state and “Black” state. Rise time (T_r) is the time between photo detector output intensity changed from 10% to 90%. And fall time (T_f) is the time between photo detector output intensity changed from 90% to 10%.

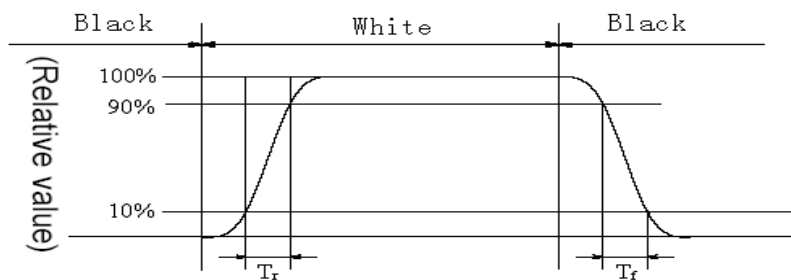

Fig4.Response Time Testing(SFT)

Note5: Definition of color chromaticity (CIE1931)

Color coordinates measured at center point of LCD.

Note6: Definition of Luminance Uniformity

Active area is divided into 9 measuring areas (Refer Fig.5). Every measuring point is placed at the center of each measuring area.

$$\text{Luminance Uniformity (U)} = L_{\min} / L_{\max}$$

L_{\max} : The measured Maximum luminance of all measurement position.

L_{\min} : The measured Minimum luminance of all measurement position.

L-----Active area length; W----- Active area width

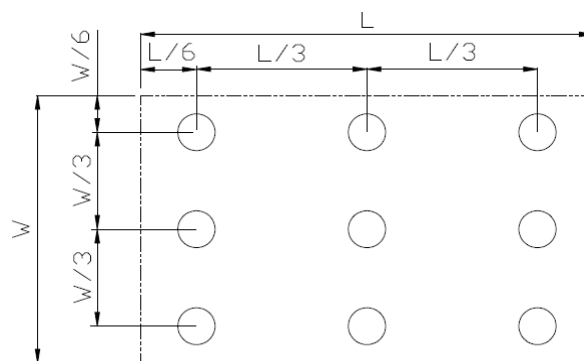

Fig5. Luminance Uniformity Measurement Locations(9 points)

Note7: Definition of Luminance:

Measure the luminance of white state at center point.

8. Reliability Test

No	Test Item	Condition	Judgment Note1
1	High Temperature Operation	① +70±3°C, 240hours Note2 ② Display data is white.	No display malfunctions
2	High Temperature & High Humidity Operation	① +60±2°C, RH= 90%, 240hours ② Display data is white.	
3	Thermal Shock (non-operation)	① -30 ± 3°C...30minutes +80 ± 3°C...30minutes ② 100cycles, 1hour/cycle ③ Temperature transition time is within 5 minutes.	
4	Heat Cycle (Operation)	①-20±3°C...1hour 70±3°C...1hour ②50cycles, 4hours/cycle ③Display data is White.	
5	ESD(Operation)	① 150pF, R=150Ω,15kV ② 9 places on a panel surface Note3 ③ 10 times each point at 1 sec interval	
6	Vibration (Non-operation)	① 5 to 100Hz, 11.76m/s ² ② 1 minute/cycle ③ X, Y, Z directions ④ 50 times each direction	No display malfunctions No physical damages
7	Shock (Non-operation)	① 294m/ s ² , 11ms ② ±X, ±Y, ±Z directions ③ 3 times each direction	
8	Image retention (Room temperature)	① Room temperature(25 ± 3°C) ② Display pattern is H/20 x H/20 checker-flag ③ Burning time:24 hours	Check pattern 51/256 Check time: after 5mins

Table 8.1 RA test condition

Note1: Temperature is the ambient temperature of sample

Note2: Before cosmetic and function test, the product must have enough recovery time, at least 2 hours at room temperature.

Note3: In the standard condition, there shall be no practical problem that may affect the display function. After the reliability test, the product's function only be guaranteed, but not for all of the cosmetic specification.

9. Mechanical Drawing

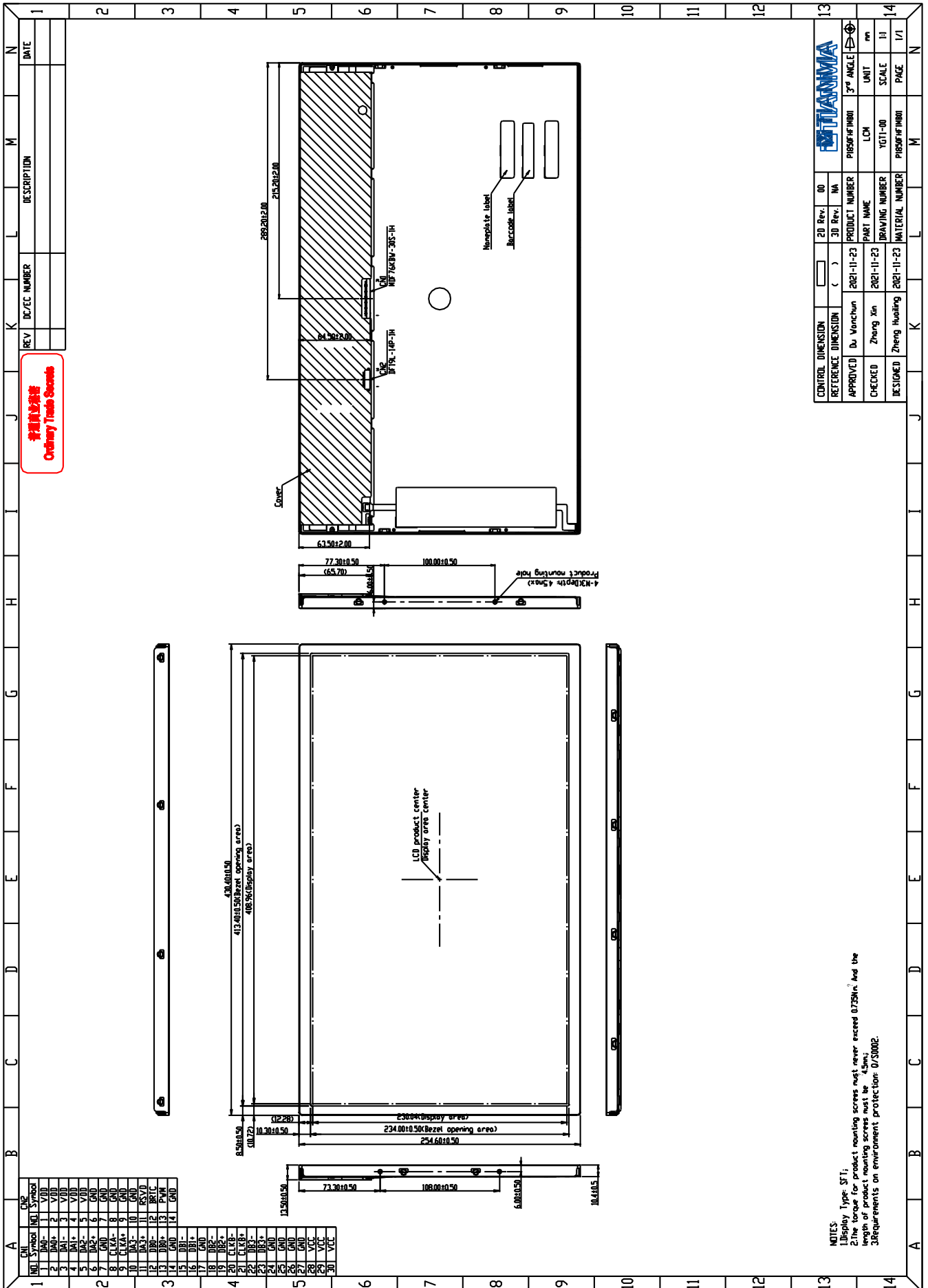

CONTROL DIMENSION	2D Rev. 00	MA
REFERENCE DIMENSION	3D Rev.	NA
APPROVED	Du Wanchun	2021-11-23
CHECKED	Zheng Xin	2021-11-23
DESIGNED	Zheng Hualing	2021-11-23
PRODUCT NUMBER	P1850HF1MB01	3 rd ANGLE
PART NAME	LCH	UNIT
DRAWING NUMBER	YG11-00	SCALE
MATERIAL NUMBER	P1850HF1MB01	PAGE
TIANMA		

NOTES:
 1. Display Type: SFT1;
 2. The torque for product mounting screws must never exceed 0.75Nm. And the tightness of product mounting screws must be checked after assembly.
 3. Requirements on environment protection: 0/3500E2.

10. Packing Instruction

No	Item	Model (Material)	Dimensions(m m)	Unit Weight(Kg)	Q'ty	Remark
1	LCM module	P1850FHF1MB01	430.4x254.6x13.5	1.557	5	
2	Partition board	Corrugated paper	491x255x5	0.05	2	
3	Anti-static Bag	LD-PE	600x420mm	0.022	5	
4	EPP-Bottom	EPP	532.4x433.5x170	0.476	1	
5	EPP-Top	EPP	433.5x188.3x90	0.055	2	
6	Carton	Corrugated paper	536x437x370	1.238	1	
7	Barcode Label	Paper	76x104	0.001	1	
8	Total weight	9.82 ±10% kg				
8	Total weight	9.82 ±10% kg				

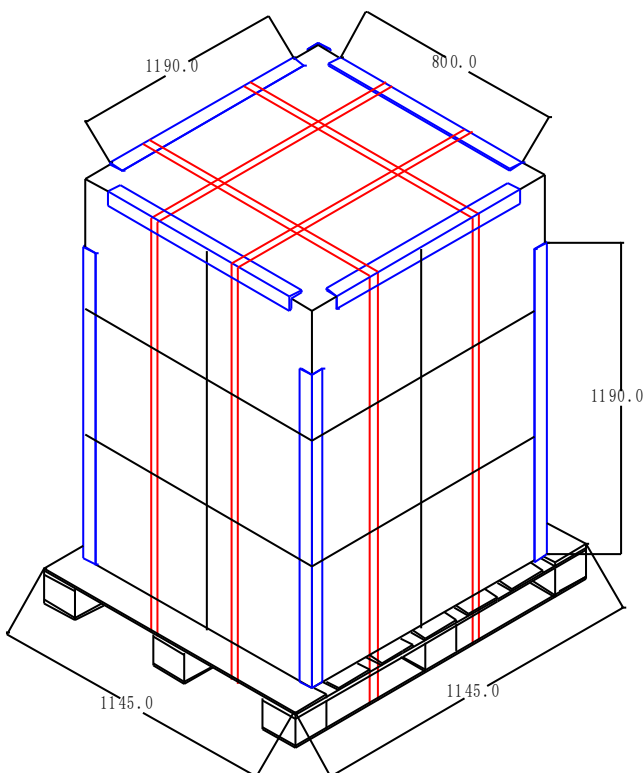

11. Precautions for Use of LCD Modules

11.1 Handling Precautions

- (1) The display panel is made of glass. Do not subject it to mechanical shock by dropping it, etc.
- (2) If the display panel is damaged and the liquid crystal fluid inside it leaks out be sure not to get any in your mouth. If the fluid comes into contact with your skin or clothes promptly wash it off using soap and water.
- (3) Do not apply excessive force to the display surface or the bezel since this may cause the color tone to vary.
- (4) The polarizer covering the display surface of the LCD module is soft and easily scratched. Handle the polarizer carefully.
- (5) If the display surface is contaminated, breathe on the surface and gently wipe it with a soft dry cloth. If it is still not completely clear use a moist cloth with one of the following solvents:
 - Isopropyl alcohol
 - Ethyl alcoholSolvents other than those mentioned above may damage the polarizer. Specifically, do not use the following:
 - Water
 - Ketone
 - Aromatic solvents
- (6) Do not disassemble the LCD Module.
- (7) If powered off, do not apply the input signals.
- (8) To prevent destruction of the module by static electricity, be careful to maintain an optimum work environment.
- (9) Be sure to ground your body when handling the LCD Modules.
- (10) Tools used for assembly, must be properly grounded.
- (11) To reduce the amount of static electricity generated, do not conduct assembly or other work under very low humidity conditions.
- (12) The LCD Module is covered with a film to protect the display surface, remove film slowly under the ionizer.

11.2 Storage precautions

- (1) When storing the LCD modules avoid exposure to direct sunlight or to the light of fluorescent lamps.
- (2) The LCD modules should be stored within the rated storage temperature range. If the LCD modules will be stored for a long time, the recommend condition is: Temperature: 0 ~ 35 °C at normal humidity.
- (3) The LCD modules should be stored in a room without acid, alkali or other harmful gas.

11.3 Transportation Precautions

The LCD modules should not be dropped or subject to violent mechanical shock during transportation. Also they should avoid excessive pressure, water, high humidity and direct sunlight.

11.4 Screen saver Precautions

Not display the fixed pattern for a long time. Use a screen saver, if the fixed pattern is displayed on the screen

11.5 Safety Precautions

- (1) When you waste damaged or unnecessary LCDs, it is recommended to crush LCDs into pieces and wash them off with solvents such as acetone and ethanol, which should later be burned
- (2) Be sure to turn off the power supply when inserting or disconnecting the LED backlight cable.
- (3) LED driver should be designed carefully to limit or stop its function when over current is detected on the LED.



ALL TECHNOLOGIES. ALL COMPETENCIES. ONE SPECIALIST.

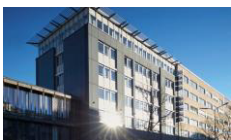

DATA MODUL AG
Landsberger Straße 322
DE-80687 Munich
Phone: +49-89-56017-0

DATA MODUL WEIKERSHEIM GMBH
Lindenstraße 8
DE-97990 Weikersheim
Phone: +49-7934-101-0

