



SPECIFICATION

INNOLUX

R190EFE-L62

19" TFT - SXGA - LVDS

Version: 1.0

Date: 14.03.2014

Note: This specification is subject to change without prior notice

Doc. Number :

- Tentative Specification
- Preliminary Specification
- Approval Specification

MODEL NO.: R190EFE
SUFFIX: L62

Customer:	
APPROVED BY	SIGNATURE
Name / Title _____	_____
<p>Please return 1 copy for your confirmation with your signature and comments.</p>	

Approved By	Checked By	Prepared By
		Forrest Lin

CONTENTS

1. GENERAL DESCRIPTION	5
1.1 OVERVIEW	5
1.2 GENERAL SPECIFICATIONS	5
2. MECHANICAL SPECIFICATIONS	5
3. ABSOLUTE MAXIMUM RATINGS	5
3.1 ABSOLUTE RATINGS OF ENVIRONMENT	5
3.2 ELECTRICAL ABSOLUTE RATINGS	6
3.2.1 TFT LCD MODULE	6
3.2.2 BACKLIGHT UNIT	6
4. ELECTRICAL SPECIFICATIONS	7
4.1 FUNCTION BLOCK DIAGRAM	7
4.1 FUNCTION BLOCK DIAGRAM	7
4.2. INTERFACE CONNECTIONS	7
4.3 ELECTRICAL CHARACTERISTICS	9
4.3.1 LCD ELETRONICS SPECIFICATION	9
4.3.2 Vcc Power Dip Condition	11
4.3.3 BACKLIGHT UNIT	11
4.3.4 CONVERTER ELECTRICAL CHARATERISTICS	12
4.3.5 CONVERTER INPUT CONNECTOR PIN ASSIGNMENT	13
4.4 LVDS INPUT SIGNAL SPECIFICATIONS	13
4.4.1 LVDS DATA INPUT DATA ORDER (VESA mode)	13
LVDS_SEL = Ground or Open	13
4.4.2 LVDS DATA INPUT DATA ORDER (JEITA mode)	13
LVDS_SEL = 3.3V	13
4.4.3 COLOR DATA INPUT ASSIGNMENT	14
4.5 DISPLAY TIMING SPECIFICATIONS	15
4.6 POWER ON/OFF SEQUENCE	17
5. OPTICAL CHARACTERISTICS	18
5.1 TEST CONDITIONS	18
5.2 OPTICAL SPECIFICATIONS	18
6. RELIABILITY TEST ITEM	22
7. PACKING	23
7.1 PACKING SPECIFICATIONS	23
7.2 PACKING METHOD	23
7.3 PALLET	24

7.4 UN-PACKING METHOD	25
8. INX MODULE LABEL	26
9. PRECAUTIONS	27
9.1 ASSEMBLY AND HANDLING PRECAUTIONS	27
9.2 STORAGE PRECAUTIONS	27
9.3 OPERATION PRECAUTIONS	27
9.4 SAFETY PRECAUTIONS	27
9.5 SAFETY STANDARDS	28
9.6 OTHER	28
Appendix. OUTLINE DRAWING	28

REVISION HISTORY

Version	Date	Section	Description
1.0	14 th , Mar., 2014	All	Preliminary Specification was first issued.

1. GENERAL DESCRIPTION

1.1 OVERVIEW

R190EFE-L62 is a 19" TFT Liquid Crystal Display module with LED Backlight unit and 30 pins and one port 2ch-LVDS interface. This module supports 1280 x 1024 SXGA and displays 16.7M colors driven by 8bit drivers. The converter module for Backlight is built in.

1.2 GENERAL SPECIFICATIONS

Item	Specification	Unit	Note
Screen Size	19" real diagonal		
Driver Element	a-si TFT active matrix	-	-
Pixel Number	1280 x R.G.B. x 1024	pixel	-
Pixel Pitch	0.294 (H) x 0.294 (V)	mm	-
Pixel Arrangement	Sub-pixel Vertical stripe	-	-
Display Colors	16.7M	color	-
Transmissive Mode	Dual domain IPS, Normally Black	-	-
Surface Treatment	AG type, 3H hard coating	-	-
Luminance, White	330	Cd/m2	
Power Consumption	Total (25.5W) @cell (5.5W) & BL (20W)		(1)

Note (1) The specified power consumption : Total= cell (reference 4.3.1)+BL (reference 4.3.3)

2. MECHANICAL SPECIFICATIONS

Item		Min.	Typ.	Max.	Unit	Note
Module Size	Horizontal (H)	395.5	396	397.5	mm	(1)
	Vertical (V)	323.5	324	324.5	mm	
	Thickness (T)	19.6	20.1	20.6	mm	
Bezel Area	Horizontal	379.8	380.3	380.8	mm	
	Vertical	304.5	305	305.5	mm	
Active Area	Horizontal		376.32		mm	
	Vertical		301.056		mm	
Weight			2110	2330	g	

Note (1) Please refer to the attached drawings for more information of front and back outline dimensions.

3. ABSOLUTE MAXIMUM RATINGS

3.1 ABSOLUTE RATINGS OF ENVIRONMENT

Item	Symbol	Value		Unit	Note
		Min.	Max.		
Storage Temperature	TST	-20	60	°C	(1)
Operating Ambient Temperature	TOP	0	50	°C	(1), (2)

Note (1)

- (a) 90 %RH Max. (Ta <= 40 °C).
- (b) Wet-bulb temperature should be 39 °C Max. (Ta > 40 °C).
- (c) No condensation.

Note (2) The temperature of panel surface should be 0 °C min. and 60 °C max.

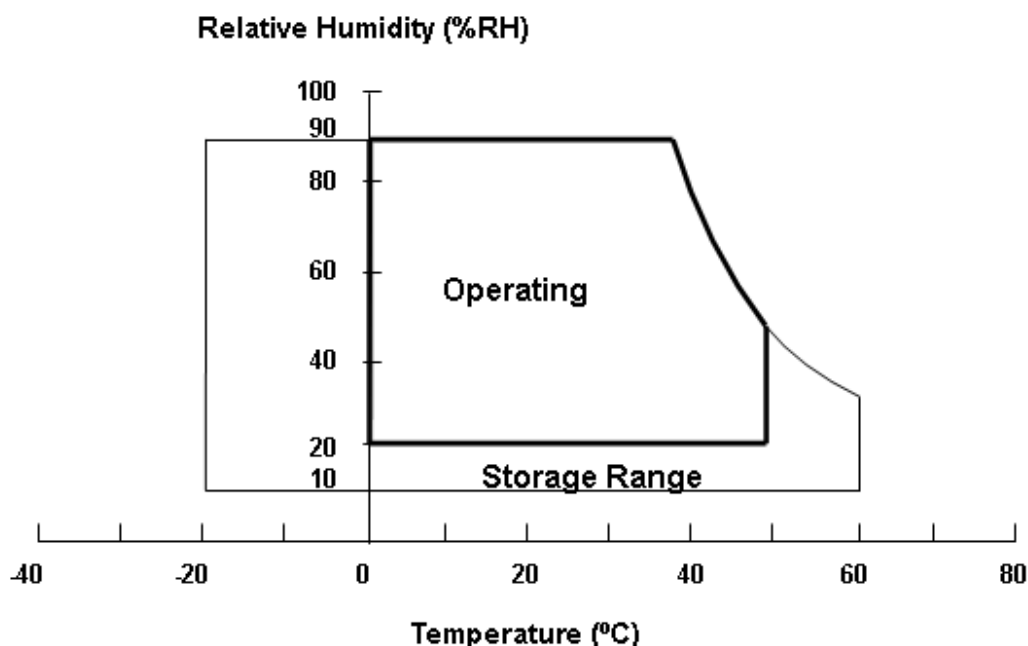

3.2 ELECTRICAL ABSOLUTE RATINGS

3.2.1 TFT LCD MODULE

Item	Symbol	Value		Unit	Note
		Min.	Max.		
Power Supply Voltage	VCCS	-0.3	5.5	V	(1)
Logic Input Voltage	V _{IN}	-0.3	4.0	V	

3.2.2 BACKLIGHT UNIT

Item	Symbol	Value			Unit	Note
		Min.	Typ	Max.		
LED Forward Current Per Input Pin	I _F	0	(120)	200	mA	(1), (2) Duty=100%
LED Pulse Forward Current Per Input Pin	I _P	---	---	200	mA	(1), (2) Pulse Width ≤ 10msec. and Duty ≤ 30%

Note (1) Permanent damage to the device may occur if maximum values are exceeded. Function operation should be restricted to the conditions described under Normal Operating Conditions.

Note (2) Specified values are for input pin of LED light bar at Ta=25±2 °C (Refer to 4.3.3 and 4.3.4 for further information).

4. ELECTRICAL SPECIFICATIONS

4.1 FUNCTION BLOCK DIAGRAM

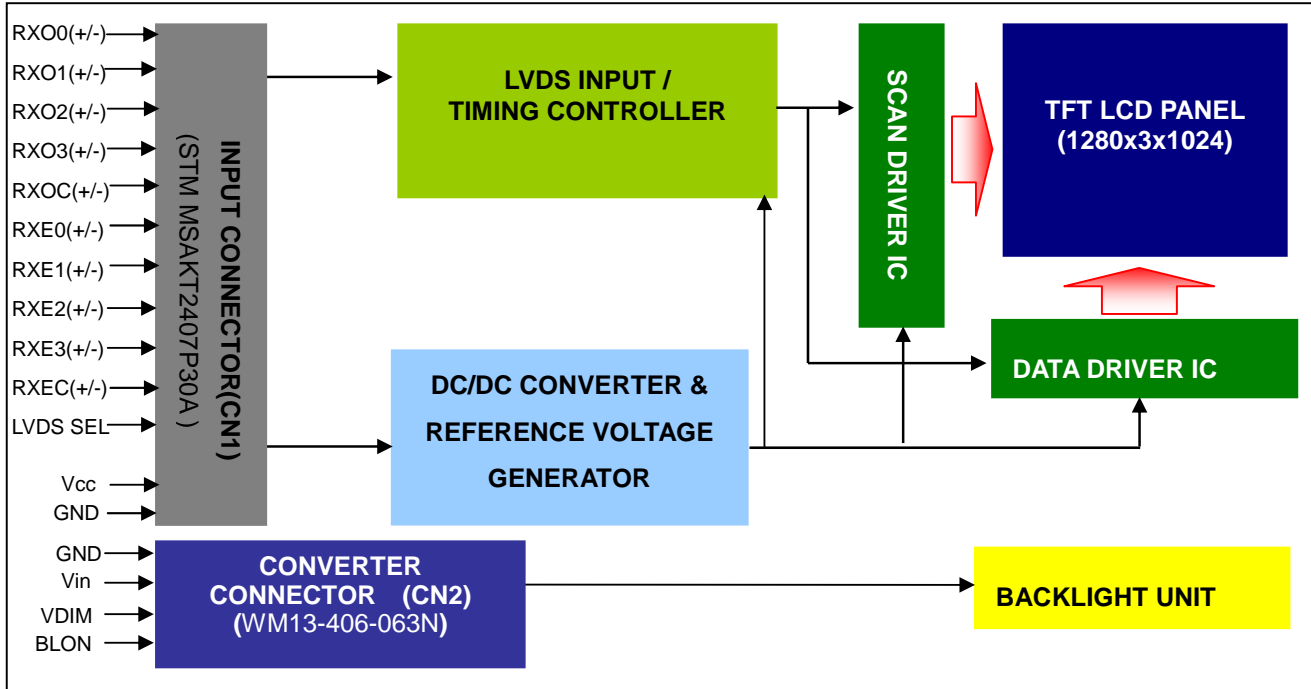

4.2. INTERFACE CONNECTIONS

PIN ASSIGNMENT

Pin	Name	Description
1	RXO0-	Negative LVDS differential data input. Channel O0 (odd)
2	RXO0+	Positive LVDS differential data input. Channel O0 (odd)
3	RXO1-	Negative LVDS differential data input. Channel O1 (odd)
4	RXO1+	Positive LVDS differential data input. Channel O1 (odd)
5	RXO2-	Negative LVDS differential data input. Channel O2 (odd)
6	RXO2+	Positive LVDS differential data input. Channel O2 (odd)
7	GND	Ground
8	RXOC-	Negative LVDS differential clock input. (odd)
9	RXOC+	Positive LVDS differential clock input. (odd)
10	RXO3-	Negative LVDS differential data input. Channel O3(odd)
11	RXO3+	Positive LVDS differential data input. Channel O3 (odd)
12	RXE0-	Negative LVDS differential data input. Channel E0 (even)
13	RXE0+	Positive LVDS differential data input. Channel E0 (even)
14	GND	Ground
15	RXE1-	Negative LVDS differential data input. Channel E1 (even)
16	RXE1+	Positive LVDS differential data input. Channel E1 (even)
17	GND	Ground
18	RXE2-	Negative LVDS differential data input. Channel E2 (even)
19	RXE2+	Positive LVDS differential data input. Channel E2 (even)
20	RXEC-	Negative LVDS differential clock input. (even)
21	RXEC+	Positive LVDS differential clock input. (even)
22	RXE3-	Negative LVDS differential data input. Channel E3 (even)
23	RXE3+	Positive LVDS differential data input. Channel E3 (even)

24	GND	Ground
25	LVDS_SEL	0:VESA Mode; 1:JEITA Mode (0 : low or open ; 1 : 3.3V)
26	NC	Not connection, this pin should be open
27	NC	Not connection, this pin should be open
28	V _{CC} (5V)	+5.0V power supply
29	V _{CC} (5V)	+5.0V power supply
30	V _{CC} (5V)	+5.0V power supply

Note (1) Connector Part No.: MSAKT2407P30A (STM)

Note (2) The first pixel is odd.

Note (3) Input signal of even and odd clock should be the same timing.

Note (4) The module uses a 100-ohm resistor between positive and negative data lines of each receiver input.

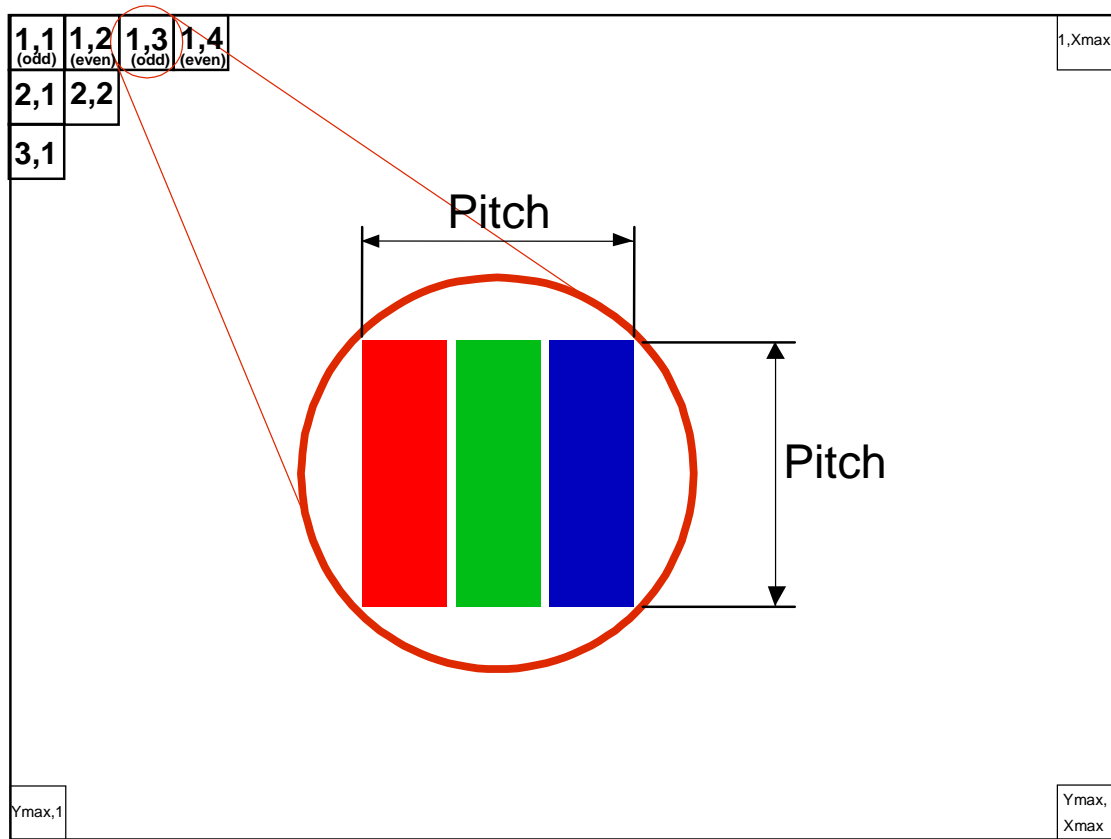

4.3 ELECTRICAL CHARACTERISTICS

4.3.1 LCD ELECTRONICS SPECIFICATION

Parameter	Symbol	Value			Unit	Note
		Min.	Typ.	Max.		
Power Supply Voltage	V _{CC}	4.5	5.0	5.5	V	-
Ripple Voltage	V _{RP}	-	-	300	mV	-
Rush Current	I _{RUSH}	-	-	3	A	(2)
Power Supply Current	White	-	(1.10)	(1.32)	A	(3)a
	Black	-	(0.86)	(1.03)	A	(3)b
	Vertical Stripe	-	(1.02)	(1.22)	A	(3)c
Power Consumption	PLCD	-	(5.5)	(6.6)	Watt	(4)
LVDS differential input voltage	V _{id}	100	-	600	mV	
LVDS common input voltage	V _{ic}	1.0	1.2	1.4	V	
LVDS Logic High Input Voltage	V _{IH}	2.64	-	-	V	
LVDS Logic Low Input Voltage	V _{IL}	-	-	0.66	V	
LVDS terminating resistor	R _T	-	100	-	ohm	

Note (1) The ambient temperature is Ta = 25 ± 2 °C.

Note (2) Measurement Conditions:

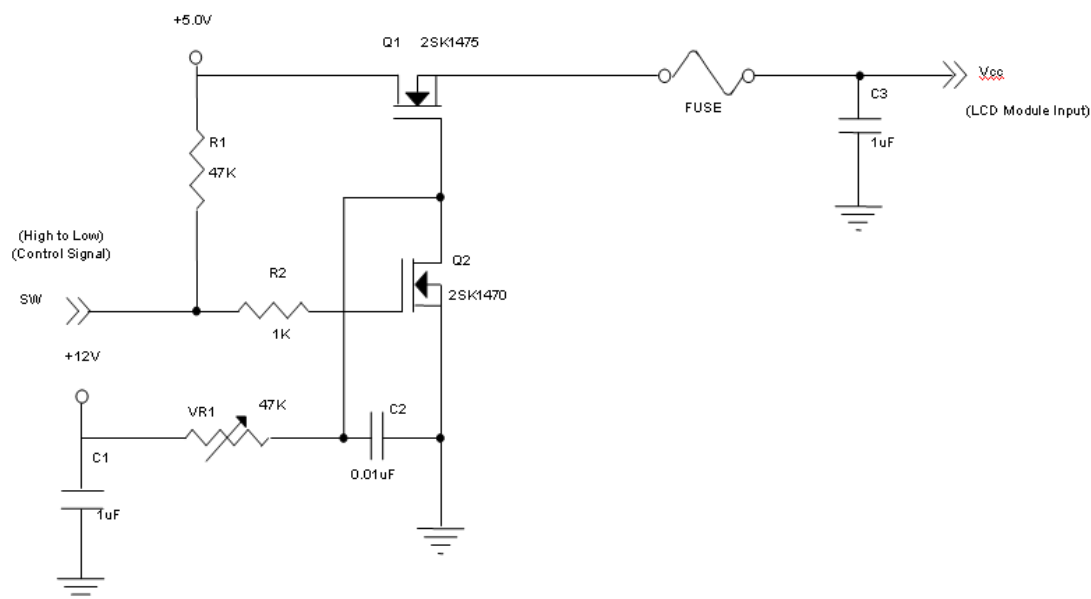

V_{CC} rising time is 470μs

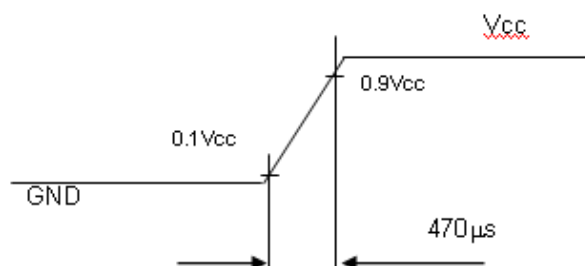

Note (3) The specified max power supply current is under the conditions at $V_{cc} = 5.0\text{ V}$, $T_a = 25 \pm 2\text{ }^\circ\text{C}$, $F_r = 60\text{ Hz}$, whereas a power dissipation check pattern below is displayed.

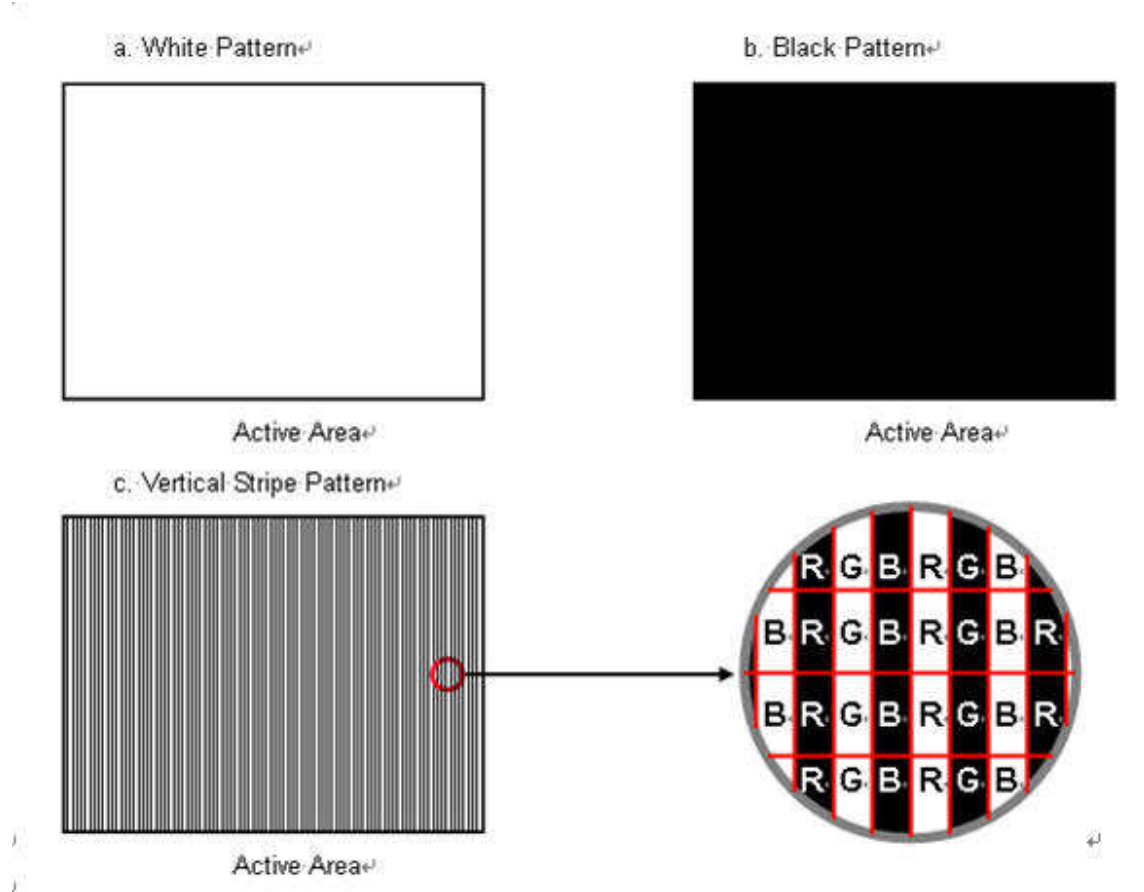

Note (4) The power consumption is specified at the pattern with the maximum current.

4.3.2 Vcc Power Dip Condition

- Dip condition: $4.0V \leq V_{cc} \leq 4.5V, T_d \leq 20ms$

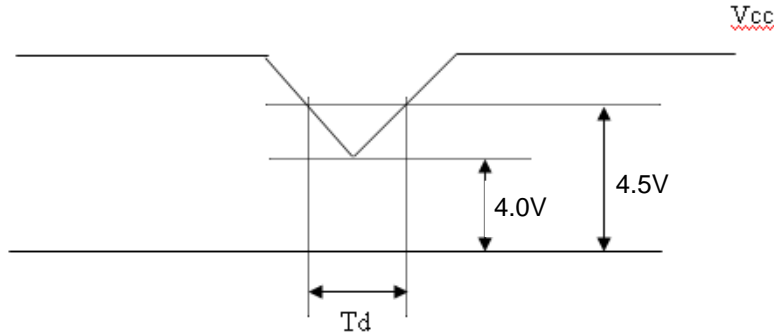

4.3.3 BACKLIGHT UNIT

Parameter	Symbol	Value			Unit	Note
		Min.	Typ.	Max.		
LED Light Bar Input Voltage Per Input Pin	VPIN	37.2		39.6	V	(1), Duty=100%, IPIN=120mA
LED Light Bar Current Per Input Pin	IPIN	---	(120)	---	mA	(1), (2) Duty=100%
LED Life Time	LLED	50000			Hrs	(3)
Power Consumption	PBL	17		20	W	(1) Duty=100%, IPIN=120mA

Note (1) LED light bar input voltage and current are measured by utilizing a true RMS multimeter as shown below:

Note (2) $PBL(Typ) = IPIN(Typ) \times VPIN(Typ) \times \text{input pins.}$ $PBL(Max) = IPIN(TYP) \times VPIN(Max) \times \text{input pins.}$

Note (3) The lifetime of LED is defined as the time when LED packages continue to operate under the conditions at $T_a = 25 \pm 2 \text{ }^\circ\text{C}$ and $I = 150\text{mA}$ (per chip) until the brightness becomes $\leq 50\%$ of its original value.

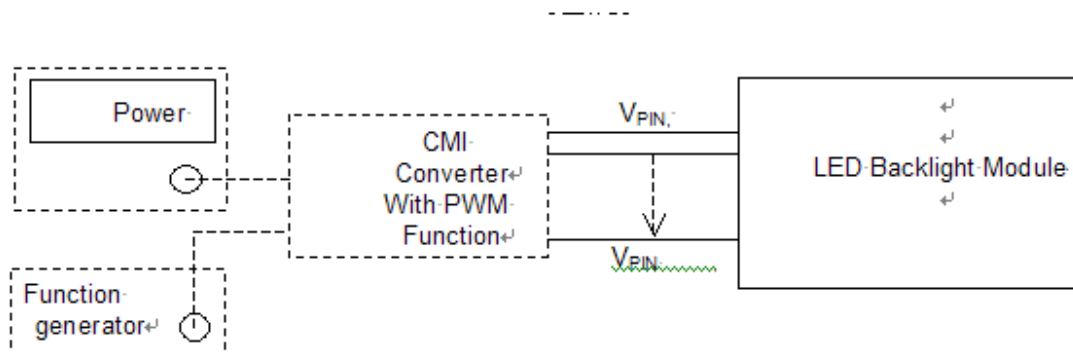

4.3.4 CONVERTER ELECTRICAL CHARACTERISTICS

Parameter	Symbol	Value			Unit	Note
		Min.	Typ.	Max.		
Converter Power Supply Voltage	V_i	10.8	12	13.2	V	(Duty 100%)
Converter Power Supply Current	I_i		1.7	2	A	@ $V_i = 12V$ (Duty 100%)
Input Power Consumption	P_o		20	22	W	@ $V_i = 12V$ (Duty 100%)
BL Control Level	Backlight on	(2)	(3.3)	(5.0)	V	
	Backlight off	0	0	(0.8)	V	
PWM Control Level	PWM High Level	(2.0)	(3.3)	(5.0)	V	
	PWM Low Level	0	0	(0.8)	V	
PWM Control Duty Ratio		5		100	%	
PWM Control Frequency	f_{PWM}	100	200	210	Hz	

Power sequence and control signal timing are shown in the following figure

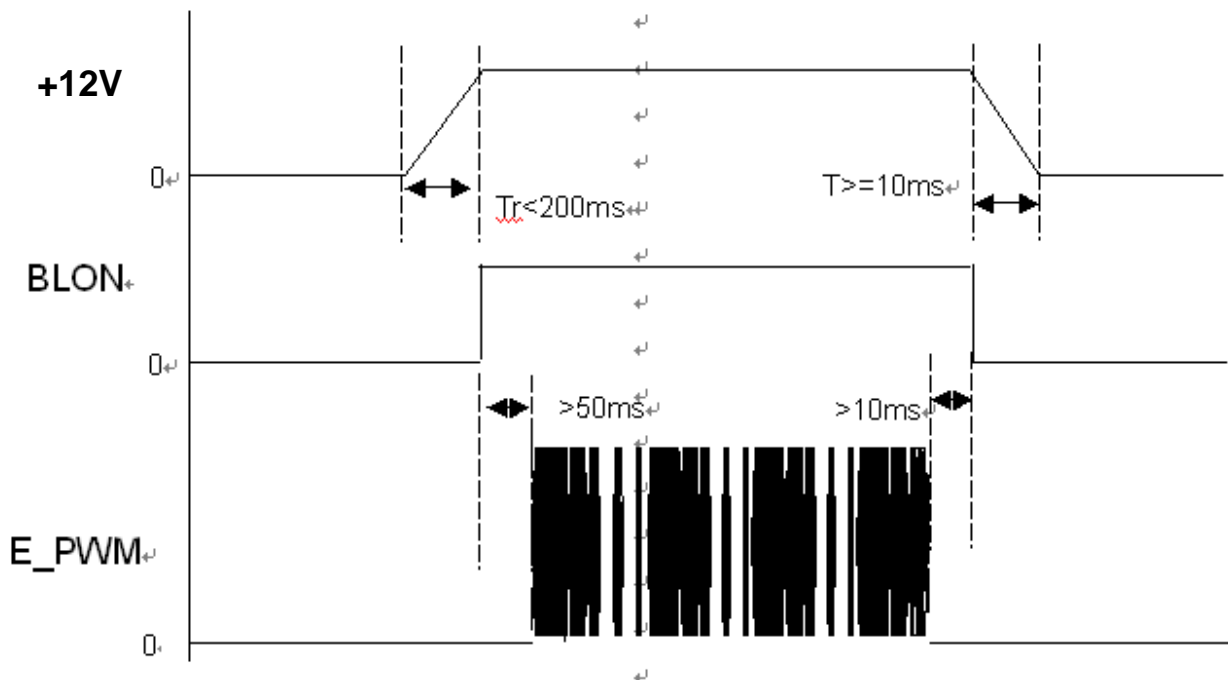

Note : While system is turned ON or OFF, the power sequences must follow as below descriptions

Turn ON sequence: $V_i(+12V) \rightarrow BLON \rightarrow E_PWM$ signal

Turn OFF sequence: E_PWM signal $\rightarrow BLON \rightarrow V_i(+12V)$

The definition of T_r : the time period of $10\% \cdot V_i$ to $90\% \cdot V_i$

The definition of T_f : the time period of $90\% \cdot V_i$ to $10\% \cdot V_i$

4.3.5 CONVERTER INPUT CONNECTOR PIN ASSIGNMENT

CN1 Connector: WM13-406-063N or equivalent

Pin number	Signal name	Feature
1	VBL	+12V
2	VBL	+12V
3	GND	GND
4	GND	GND
5	BLON	Enable 3.3V ; disable 0V
6	E_PWM	External PWM Control for Positive(100%: 3.3V, 0%: 0V)

4.4 LVDS INPUT SIGNAL SPECIFICATIONS

4.4.1 LVDS DATA INPUT DATA ORDER (VESA mode)

LVDS_SEL = Ground or Open								
LVDS Channel O0	LVDS output	D7	D6	D4	D3	D2	D1	D0
	Data order	OG0	OR5	OR4	OR3	OR2	OR1	OR0
LVDS Channel O1	LVDS output	D18	D15	D14	D13	D12	D9	D8
	Data order	OB1	OB0	OG5	OG4	OG3	OG2	OG1
LVDS Channel O2	LVDS output	D26	D25	D24	D22	D21	D20	D19
	Data order	DE	NA	NA	OB5	OB4	OB3	OB2
LVDS Channel O3	LVDS output	D23	D17	D16	D11	D10	D5	D27
	Data order	NA	OB7	OB6	OG7	OG6	OR7	OR6
LVDS Channel E0	LVDS output	D7	D6	D4	D3	D2	D1	D0
	Data order	EG0	ER5	ER4	ER3	ER2	ER1	ER0
LVDS Channel E1	LVDS output	D18	D15	D14	D13	D12	D9	D8
	Data order	EB1	EB0	EG5	EG4	EG3	EG2	EG1
LVDS Channel E2	LVDS output	D26	D25	D24	D22	D21	D20	D19
	Data order	DE	NA	NA	EB5	EB4	EB3	EB2
LVDS Channel E3	LVDS output	D23	D17	D16	D11	D10	D5	D27
	Data order	NA	EB7	EB6	EG7	EG6	ER7	ER6

4.4.2 LVDS DATA INPUT DATA ORDER (JEITA mode)

LVDS_SEL = 3.3V								
LVDS Channel O0	LVDS output	D7	D6	D4	D3	D2	D1	D0
	Data order	OG2	OR7	OR6	OR5	OR4	OR3	OR2
LVDS Channel O1	LVDS output	D18	D15	D14	D13	D12	D9	D8
	Data order	OB3	OB2	OG7	OG6	OG5	OG4	OG3
LVDS Channel O2	LVDS output	D26	D25	D24	D22	D21	D20	D19
	Data order	DE	NA	NA	OB7	OB6	OB5	OB4
LVDS Channel O3	LVDS output	D23	D17	D16	D11	D10	D5	D27
	Data order	NA	OB1	OB0	OG1	OG0	OR1	OR0
LVDS Channel E0	LVDS output	D7	D6	D4	D3	D2	D1	D0
	Data order	EG2	ER7	ER6	ER5	ER4	ER3	ER2
LVDS Channel E1	LVDS output	D18	D15	D14	D13	D12	D9	D8
	Data order	EB3	EB2	EG7	EG6	EG5	EG4	EG3
LVDS Channel E2	LVDS output	D26	D25	D24	D22	D21	D20	D19
	Data order	DE	NA	NA	EB7	EB6	EB5	EB4
LVDS Channel E3	LVDS output	D23	D17	D16	D11	D10	D5	D27
	Data order	NA	EB1	EB0	EG1	EG0	ER1	ER0

4.4.3 COLOR DATA INPUT ASSIGNMENT

The brightness of each primary color (red, green and blue) is based on the 8-bit gray scale data input for the color. The higher the binary input, the brighter the color. The table below provides the assignment of color versus data input.

Color		Data Signal																							
		Red								Green								Blue							
		R7	R6	R5	R4	R3	R2	R1	R0	G7	G6	G5	G4	G3	G2	G1	G0	B7	B6	B5	B4	B3	B2	B1	B0
Basic Colors	Black	0	0	0	0	0	0	0	0	0	0	0	0	0	0	0	0	0	0	0	0	0	0	0	0
	Red	1	1	1	1	1	1	1	1	0	0	0	0	0	0	0	0	0	0	0	0	0	0	0	0
	Green	0	0	0	0	0	0	0	0	1	1	1	1	1	1	1	1	0	0	0	0	0	0	0	0
	Blue	0	0	0	0	0	0	0	0	0	0	0	0	0	0	0	0	1	1	1	1	1	1	1	1
	Cyan	0	0	0	0	0	0	0	0	1	1	1	1	1	1	1	1	1	1	1	1	1	1	1	1
	Magenta	1	1	1	1	1	1	1	1	0	0	0	0	0	0	0	0	1	1	1	1	1	1	1	1
	Yellow	1	1	1	1	1	1	1	1	1	1	1	1	1	1	1	1	0	0	0	0	0	0	0	0
	White	1	1	1	1	1	1	1	1	1	1	1	1	1	1	1	1	1	1	1	1	1	1	1	1
Gray Scale Of Red	Red(0) / Dark	0	0	0	0	0	0	0	0	0	0	0	0	0	0	0	0	0	0	0	0	0	0	0	0
	Red(1)	0	0	0	0	0	0	0	1	0	0	0	0	0	0	0	0	0	0	0	0	0	0	0	0
	Red(2)	0	0	0	0	0	0	1	0	0	0	0	0	0	0	0	0	0	0	0	0	0	0	0	0
	⋮	⋮	⋮	⋮	⋮	⋮	⋮	⋮	⋮	⋮	⋮	⋮	⋮	⋮	⋮	⋮	⋮	⋮	⋮	⋮	⋮	⋮	⋮	⋮	⋮
	⋮	⋮	⋮	⋮	⋮	⋮	⋮	⋮	⋮	⋮	⋮	⋮	⋮	⋮	⋮	⋮	⋮	⋮	⋮	⋮	⋮	⋮	⋮	⋮	⋮
	Red(253)	1	1	1	1	1	1	0	1	0	0	0	0	0	0	0	0	0	0	0	0	0	0	0	0
	Red(254)	1	1	1	1	1	1	1	0	0	0	0	0	0	0	0	0	0	0	0	0	0	0	0	0
	Red(255)	1	1	1	1	1	1	1	1	0	0	0	0	0	0	0	0	0	0	0	0	0	0	0	0
Gray Scale Of Green	Green(0)/Dark	0	0	0	0	0	0	0	0	0	0	0	0	0	0	0	0	0	0	0	0	0	0	0	0
	Green(1)	0	0	0	0	0	0	0	0	0	0	0	0	0	0	1	0	0	0	0	0	0	0	0	
	Green(2)	0	0	0	0	0	0	0	0	0	0	0	0	0	0	1	0	0	0	0	0	0	0	0	
	⋮	⋮	⋮	⋮	⋮	⋮	⋮	⋮	⋮	⋮	⋮	⋮	⋮	⋮	⋮	⋮	⋮	⋮	⋮	⋮	⋮	⋮	⋮	⋮	
	⋮	⋮	⋮	⋮	⋮	⋮	⋮	⋮	⋮	⋮	⋮	⋮	⋮	⋮	⋮	⋮	⋮	⋮	⋮	⋮	⋮	⋮	⋮	⋮	
	Green(253)	0	0	0	0	0	0	0	0	1	1	1	1	1	1	0	1	0	0	0	0	0	0	0	
	Green(254)	0	0	0	0	0	0	0	0	1	1	1	1	1	1	1	0	0	0	0	0	0	0	0	
	Green(255)	0	0	0	0	0	0	0	0	1	1	1	1	1	1	1	1	0	0	0	0	0	0	0	
Gray Scale Of Blue	Blue(0) / Dark	0	0	0	0	0	0	0	0	0	0	0	0	0	0	0	0	0	0	0	0	0	0	0	0
	Blue(1)	0	0	0	0	0	0	0	0	0	0	0	0	0	0	0	0	0	0	0	0	0	0	0	1
	Blue(2)	0	0	0	0	0	0	0	0	0	0	0	0	0	0	0	0	0	0	0	0	0	0	1	0
	⋮	⋮	⋮	⋮	⋮	⋮	⋮	⋮	⋮	⋮	⋮	⋮	⋮	⋮	⋮	⋮	⋮	⋮	⋮	⋮	⋮	⋮	⋮	⋮	
	⋮	⋮	⋮	⋮	⋮	⋮	⋮	⋮	⋮	⋮	⋮	⋮	⋮	⋮	⋮	⋮	⋮	⋮	⋮	⋮	⋮	⋮	⋮	⋮	
	Blue(253)	0	0	0	0	0	0	0	0	0	0	0	0	0	0	0	0	1	1	1	1	1	1	0	1
	Blue(254)	0	0	0	0	0	0	0	0	0	0	0	0	0	0	0	0	1	1	1	1	1	1	1	0
	Blue(255)	0	0	0	0	0	0	0	0	0	0	0	0	0	0	0	0	1	1	1	1	1	1	1	1

Note (1) 0: Low Level Voltage, 1: High Level Voltage

4.5 DISPLAY TIMING SPECIFICATIONS

The input signal timing specifications are shown as the following table and timing diagram.

Signal	Item	Symbol	Min.	Typ.	Max.	Unit	Note
LVDS Clock	Frequency	F _c	45.74	54	75.03	MHz	-
	Period	T _c	13.33	18.5	21.8	ns	-
	Input cycle to cycle jitter	T _{rcj}	-0.02*T _c	---	0.02*T _c	ns	(1)
	Input Clock to data skew	TLVCCS	-0.02*T _c	-	0.02*T _c	ps	(2)
	Spread spectrum modulation range	F _{clk_in_mod}	-	-	400	MHz	(3)
	Spread spectrum modulation frequency	F _{SSM}	-	-	200	KHz	
Vertical Display Term	Frame Rate	Fr	56	60	75	Hz	T _v =T _v d+T _v b
	Total	T _v	1034	1066	1124	Th	-
	Active Display	T _v d	1024	1024	1024	Th	-
	Blank	T _v b	T _v -T _v d	42	T _v -T _v d	Th	-
Horizontal Display Term	Total	T _h	790	844	890	T _c	T _h =T _h d+T _h b
	Active Display	T _h d	640	640	640	T _c	-
	Blank	T _h b	T _h -T _h d	204	T _h -T _h d	T _c	-

Note: Because this module is operated by DE only mode, Hsync and Vsync input signals should be set to low logic level or ground. Otherwise, this module would operate abnormally.

INPUT SIGNAL TIMING DIAGRAM

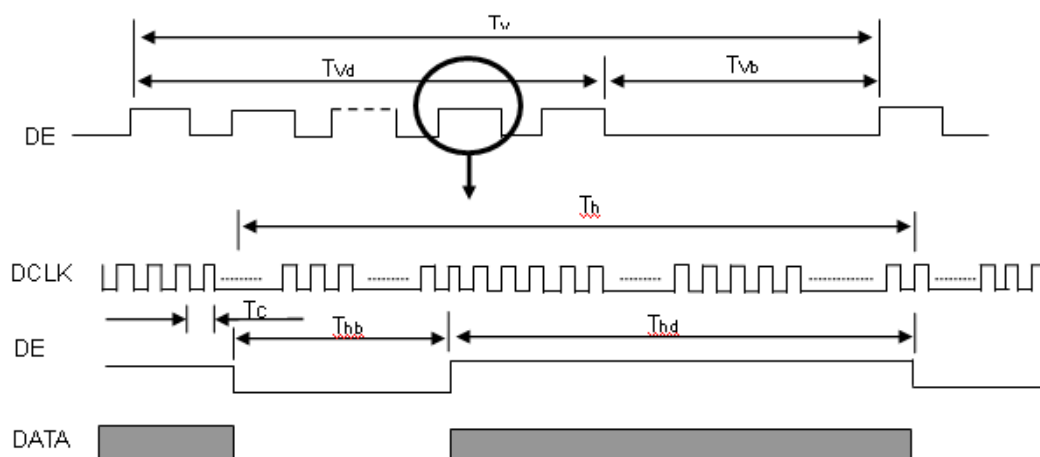

Note (1) The input clock cycle-to-cycle jitter is defined as below figures. $T_{rcj} = |T_1 - T_2|$

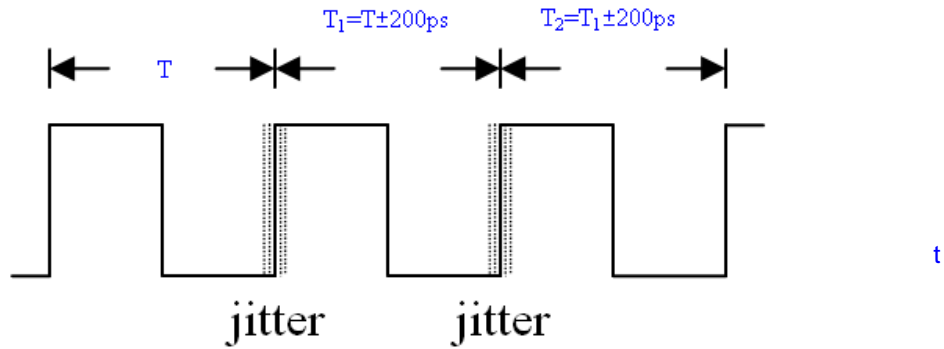

Note (2) The SSCG (Spread spectrum clock generator) is defined as below figures.

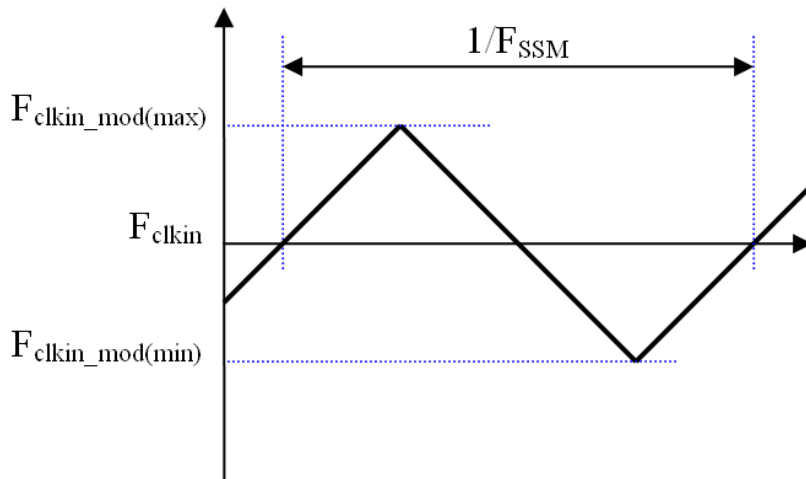

Note(3) The LVDS timing diagram and setup/hold time is defined and showing as the following figures.

LVDS RECEIVER INTERFACE TIMING DIAGRAM

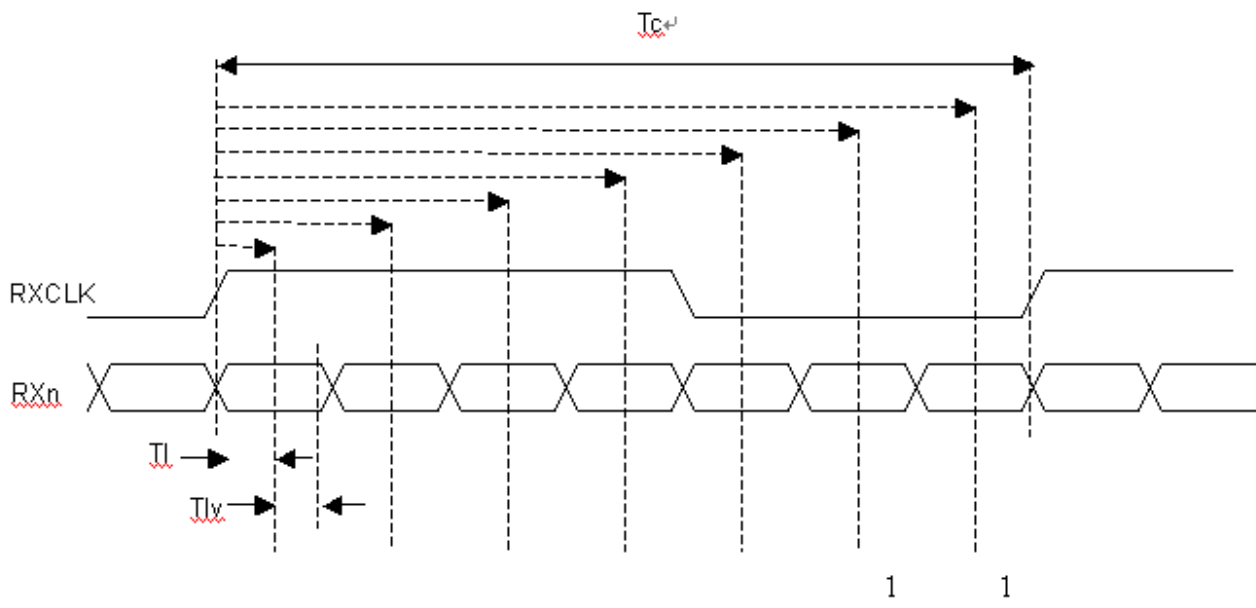

4.6 POWER ON/OFF SEQUENCE

To prevent a latch-up or DC operation of LCD module, the power on/off sequence should be as the diagram below.

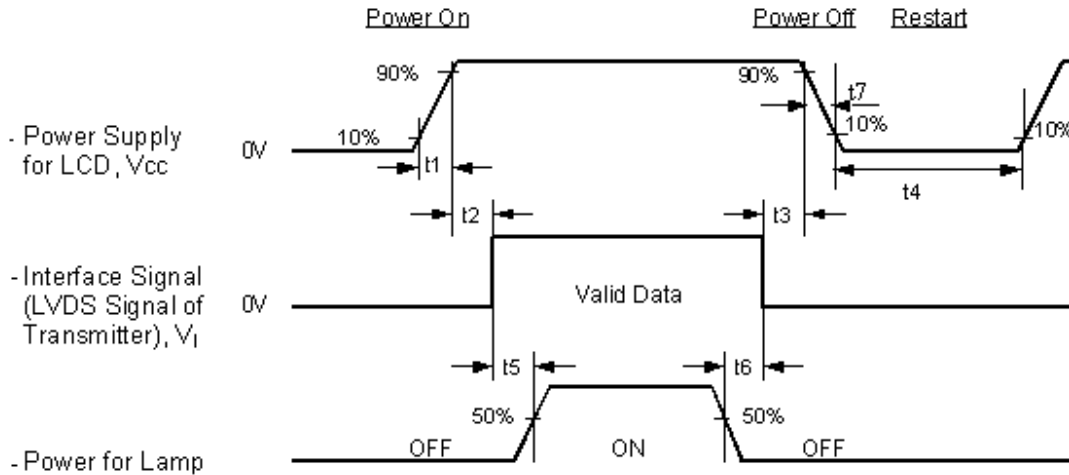

Timing Specifications:

Parameters	Values			Units
	Min	Typ.	Max	
T1	0.5	-	10	msec
T2	0	-	50	msec
T3	0	-	50	msec
T4	500	-	-	msec
T5	450	-	-	msec
T6	90	-	-	msec
T7	5	-	100-	msec

Note (1) The supply voltage of the external system for the module input should be the same as the definition of V_{CC}.

Note (2) Apply the lamp voltage within the LCD operation range. When the backlight turns on before the LCD operation of the LCD turns off before the backlight turns off, the display may momentarily become abnormal screen.

Note (3) In case of V_{CC} = off level, please keep the level of input signals on the low or keep a high impedance.

Note (4) T4 should be measured after the module has been fully discharged between power of and on period.

Note (5) Interface signal shall not be kept at high impedance when the power is on.

Note (6) It is not guaranteed that products are damaged which is caused by not following the Power Sequence.

Note (7) It is suggested that V_{CC} falling time follows T7 specification; else slight noise is likely to occur when LCD is turned off (even backlight is already off).

5. OPTICAL CHARACTERISTICS

5.1 TEST CONDITIONS

Item	Symbol	Value	Unit
Ambient Temperature	Ta	25±2	°C
Ambient Humidity	Ha	50±10	%RH
Supply Voltage	V _{CC}	5	V
Input Signal	According to typical value in "3. ELECTRICAL CHARACTERISTICS"		
PWM Duty Ratio	D	100	%

5.2 OPTICAL SPECIFICATIONS

The relative measurement methods of optical characteristics are shown in 5.2. The following items should be measured under the test conditions described in 5.1 and stable environment shown in Note (5).

Item	Symbol	Condition	Min.	Typ.	Max.	Unit	Note						
Color Chromaticity (CIE 1931)	Red	$\theta_x=0^\circ, \theta_y=0^\circ$ CS-1000T	Typ.- 0.03	(0.640)	Typ.+ 0.03	-	(1), (5)						
				(0.330)									
	Green			(0.335)									
				(0.610)									
	Blue			(0.150)									
				(0.040)									
	White			0.313									
				0.329									
	Center Luminance of White			L _C					(300)	330	---	cd/m ²	(4), (5)
	Contrast Ratio			CR					(800)	(1000)	---	-	(2), (5)
Response Time	T _R	$\theta_x=0^\circ, \theta_y=0^\circ$	---	(15)	(20)	ms	(3)						
	T _F			(15)	(20)	ms							
White Variation(adjacent)	δW_a	$\theta_x=0^\circ, \theta_y=0^\circ$ USB2000	90	---	---	%	(5), (6)						
White Variation(total)	δW_t	$\theta_x=0^\circ, \theta_y=0^\circ$ USB2000	70	---	---	%	(5), (6)						
Viewing Angle	θ_{y+}	CR ≥ 10 USB2000	80	89	---	Deg.	(1), (5)						
	θ_{y-}			89									
	θ_{x+}			89									
	θ_{x-}			89									

Note (1) Definition of Viewing Angle (θ_x, θ_y):

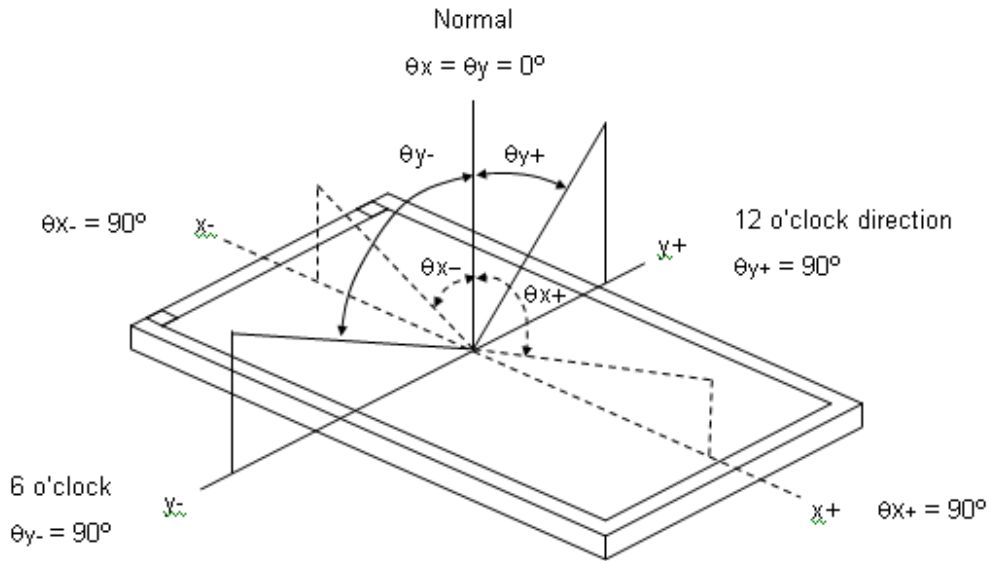

Note (2) Definition of Contrast Ratio (CR):

The contrast ratio can be calculated by the following expression.

$$\text{Contrast Ratio (CR)} = L_{255} / L_0$$

L255: Luminance of gray level 255

L 0: Luminance of gray level 0

$$\text{CR} = \text{CR} (5)$$

CR (X) is corresponding to the Contrast Ratio of the point X at Figure in Note (4).

Note (3) Definition of Response Time (T_{on}, T_{off}):

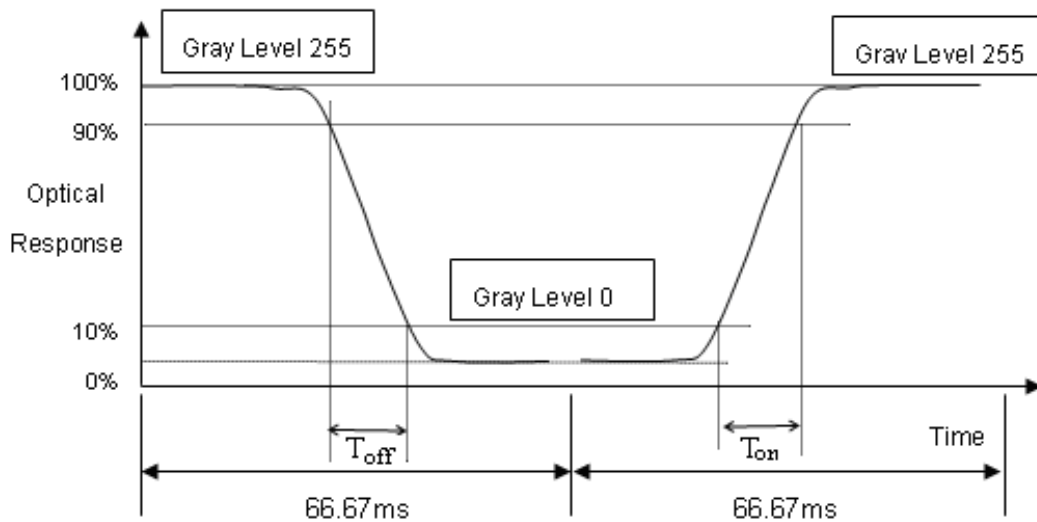

Note (4) Definition of Luminance of White (L_C):

Measure the luminance of gray level 255 at center point

$$L_C = L(5)$$

$L(x)$ is corresponding to the luminance of the point X at the following figure.

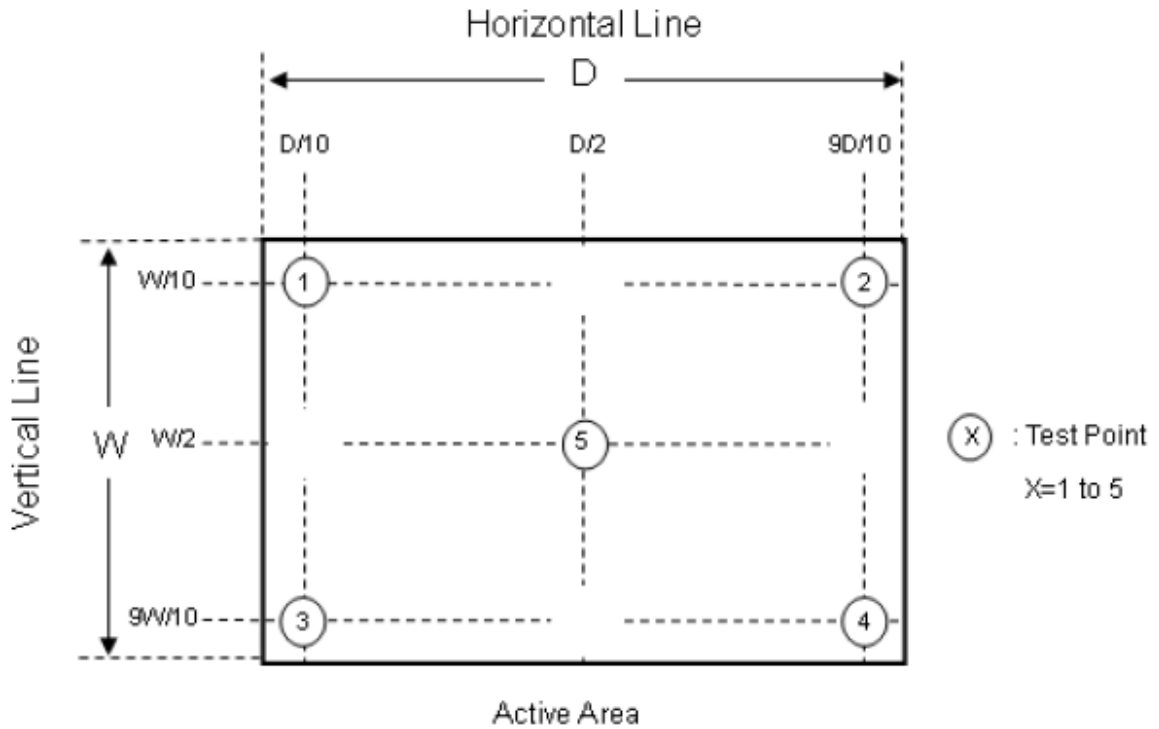

Note (5) Measurement Setup:

The LCD module should be stabilized at given temperature for 60 minutes to avoid abrupt temperature change during measuring. In order to stabilize the luminance, the measurement should be executed after lighting Backlight for 60 minutes in a windless room.

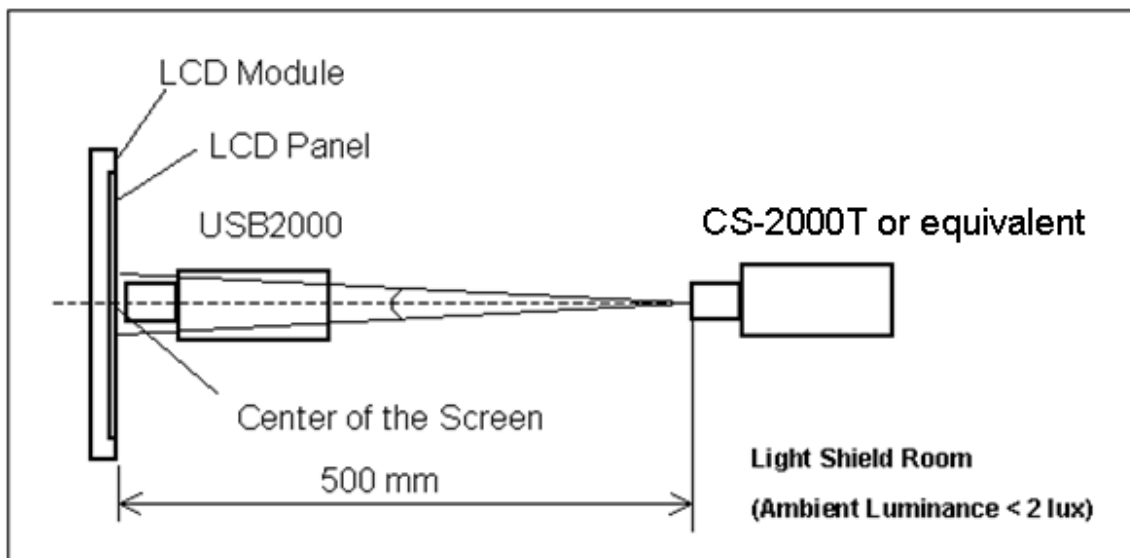

Note (6) There is the Uniformity Measurement below:

'L_{bright}' represents the Luminance of the point that is brighter than the other point to be compared.

'L_{dark}' represents the Luminance of the point that is darker than the other point to be compared.

Measuring points are shown in the following Fig.

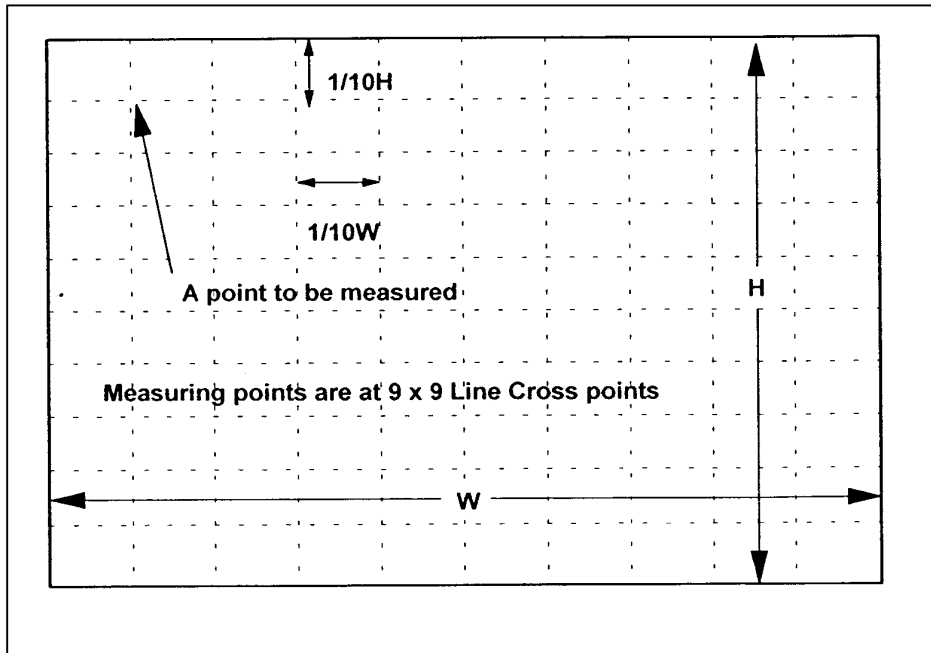

When the backlight is on with all pixels in the white (maximum gray) level, the luminance uniformity is defined as follows;

Where:

L_{bright}: The luminance of the brightness part of the area

L_{dark}: The luminance of the darkest part of the area

1. Adjacent Area

$$\text{Luminance Uniformity} = \frac{L_{\text{dark}}}{L_{\text{bright}}} \geq 0.90$$

over a circular area of 10mm diameter placed anywhere on the screen.

2. Screen Total

$$\text{Luminance Uniformity} = \frac{L_{\text{dark}}}{L_{\text{bright}}} \geq 0.70$$

over the entire screen.

6. RELIABILITY TEST ITEM

Items	Required Condition	Note
Temperature Humidity Bias (THB)	Ta= 50°C , 80%RH, 240hours	
High Temperature Operation (HTO)	Ta= 50°C , 240hours	
Low Temperature Operation (LTO)	Ta= 0°C , 240hours	
High Temperature Storage (HTS)	Ta= 60°C , 240hours	
Low Temperature Storage (LTS)	Ta= -20°C , 240hours	
Vibration Test (Non-operation)	Acceleration: 1.5 G Wave: sine Frequency: 10 - 300 Hz Sweep: 30 Minutes each Axis (X, Y, Z)	
Shock Test (Non-operation)	Acceleration: 50 G Wave: Half-sine Active Time: 11 ms Direction : ± X, ± Y, ± Z.(one time for each Axis)	
Thermal Shock Test (TST)	-20°C/30min , 60°C / 30min , 100 cycles	
On/Off Test	25°C ,On/10sec , Off /10sec , 30,000 cycles	
Altitude Test	Operation:10,000 ft / 24hours Non-Operation:30,000 ft / 24hours	
Temperature Humidity Bias (THB)	Ta= 50°C , 80%RH, 240hours	Non Operation
High Temperature Operation (HTO)	Ta= 50°C , 240hours	Non Operation

Note (1) criteria : Normal display image with no obvious non-uniformity and no line defect.

Note (2) Evaluation should be tested after storage at room temperature for more than two hour

Note (3) At testing Vibration and Shock, the fixture in holding the module has to be hard and rigid enough so that the module would not be twisted or bent by the fixture.

The fixing condition is shown as below:

At Room Temperature

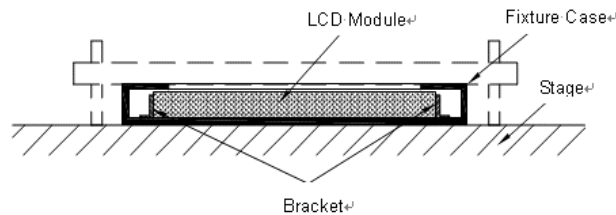

7. PACKING

7.1 PACKING SPECIFICATIONS

- (1) 11 LCD modules / 1 Box
- (2) Box dimensions: 567(L)*477(W)*416(H)mm
- (3) Weight: approximately: (23.85) kg

7.2 PACKING METHOD

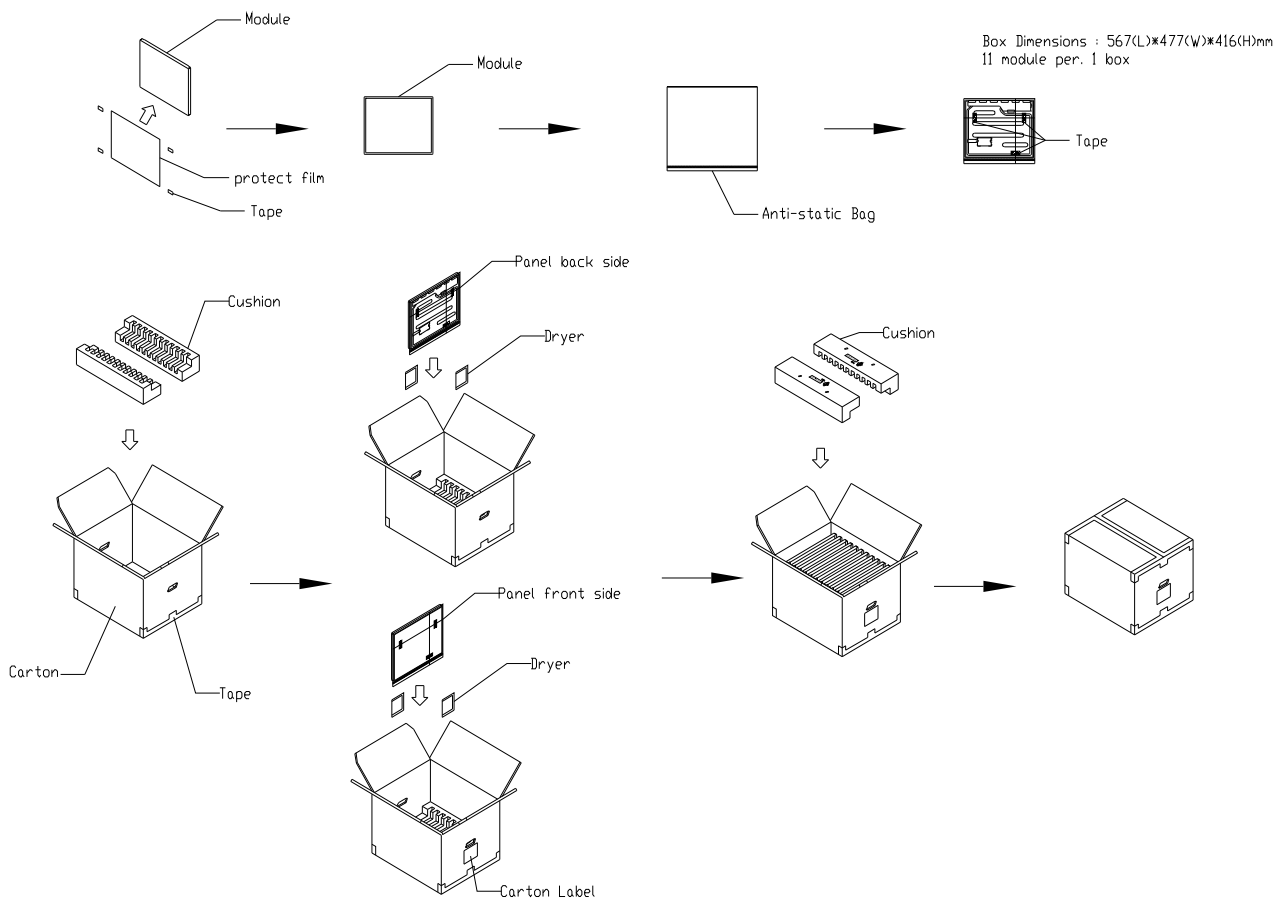
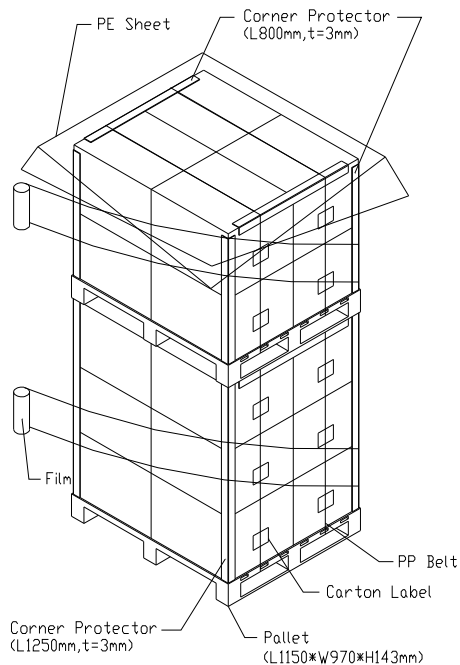

Figure. 7-1 Packing method

7.3 PALLET

Sea / Land Transportation
(40ft HQ Container)



Sea / Land Transportation
(40ft Container)

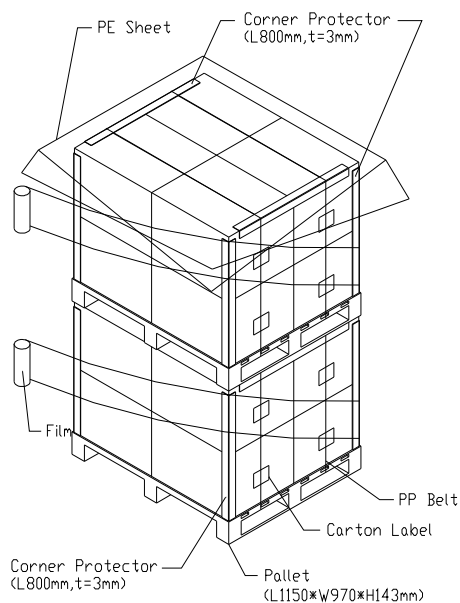

Air Transportation

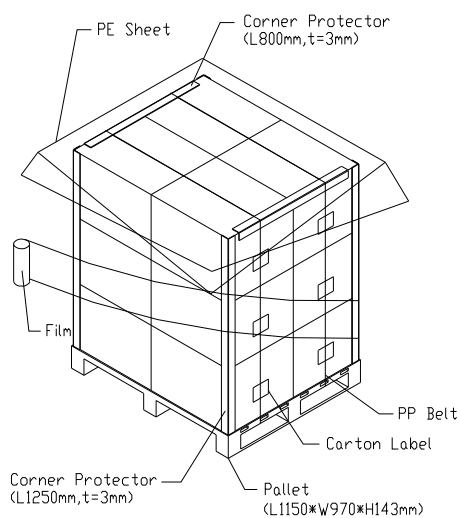

Figure. 7-2 Packing method

7.4 UN-PACKING METHOD

UN-packaging method is shown as following figures.

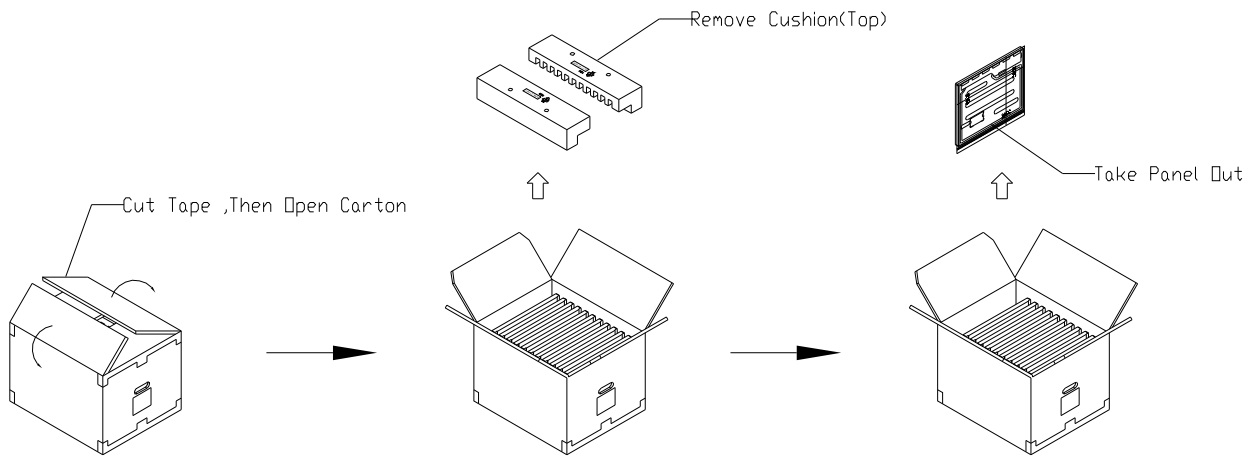
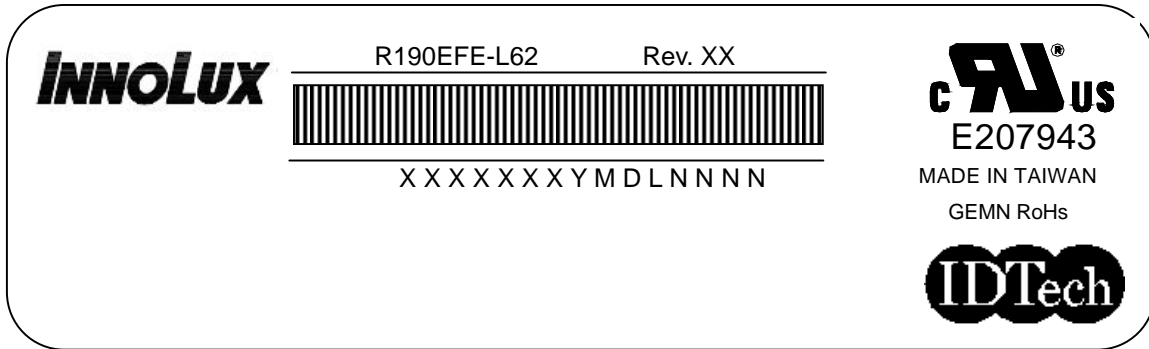

Figure. 7-3 Un-packing method

8. INX MODULE LABEL

The barcode nameplate is pasted on each module as illustration, and its definitions are as following explanation.



(a) Model Name: R190EFE-L62

(b) Revision: Rev. XX, for example: A0, A1... B1, B2... or C1, C2...etc.

(c) INX barcode definition:

Serial ID: XX-XX-X-XX-YMD-L-NNNN

Code	Meaning	Description
XX	INX internal use	-
XX	Revision	Cover all the change
X	INX internal use	-
XX	INX internal use	-
YMD	Year, month, day	Year: 0~9, 2010=0, 2011=1, 2012=2... Month: 1~12=1, 2, 3, ~, 9, A, B, C Day: 1~31=1, 2, 3, ~, 9, A, B, C, ~, W, X, Y, exclude I, O, and U.
L	Product line #	Line 1=1, Line 2=2, Line 3=3, ...
NNNN	Serial number	Manufacturing sequence of product

9. PRECAUTIONS

9.1 ASSEMBLY AND HANDLING PRECAUTIONS

- (1) Do not apply rough force such as bending or twisting to the module during assembly.
- (2) To assemble or install module into user's system can be only in clean working areas. The dust and oil may cause electrical short or worsen the polarizer.
- (3) It's not permitted to have pressure or impulse on the module because the LCD panel and Backlight will be damaged.
- (4) Always follow the correct power sequence when LCD module is connecting and operating. This can prevent damage to the CMOS LSI chips during latch-up.
- (5) Do not pull the I/F connector in or out while the module is operating.
- (6) Do not disassemble the module.
- (7) Use a soft dry cloth without chemicals for cleaning, because the surface of polarizer is very soft and easily scratched.
- (8) It is dangerous that moisture come into or contacted the LCD module, because moisture may damage LCD module when it is operating.
- (9) High temperature or humidity may reduce the performance of module. Please store LCD module within the specified storage conditions.
- (10) When ambient temperature is lower than 10°C may reduce the display quality. For example, the response time will become slowly.

9.2 STORAGE PRECAUTIONS

- (1) Do not leave the module in high temperature, and high humidity for a long time. It is highly recommended to store the module with temperature from 0°C to 35°C and relative humidity of less than 70%
- (2) Do not store the TFT-LCD module in direct sunlight
- (3) The module should be stored in dark place. It is prohibited to apply sunlight or fluorescent light in storing

9.3 OPERATION PRECAUTIONS

- (1) The LCD product should be operated under normal condition.

Normal condition is defined as below :

Temperature : 20±15°C

Humidity: 65±20%

Display pattern : continually changing pattern(Not stationary)

- (2) If the product will be used in extreme conditions such as high temperature, high humidity, high altitude ,display pattern or operation time etc...It is strongly recommended to contact INX for application engineering advice . Otherwise, its reliability and function may not be guaranteed.

9.4 SAFETY PRECAUTIONS

- (1) If the liquid crystal material leaks from the panel, it should be kept away from the eyes or mouth. In case of contact with hands, skin or clothes, it has to be washed away thoroughly with soap.
- (2) After the module's end of life, it is not harmful in case of normal operation and storage.

9.5 SAFETY STANDARDS

The LCD module should be certified with safety regulations as follows:

- (1) UL60950-1 or updated standard.
- (2) IEC60950-1 or updated standard.

9.6 OTHER

When fixed patterns are displayed for a long time, remnant image is likely to occur.

Appendix. OUTLINE DRAWING

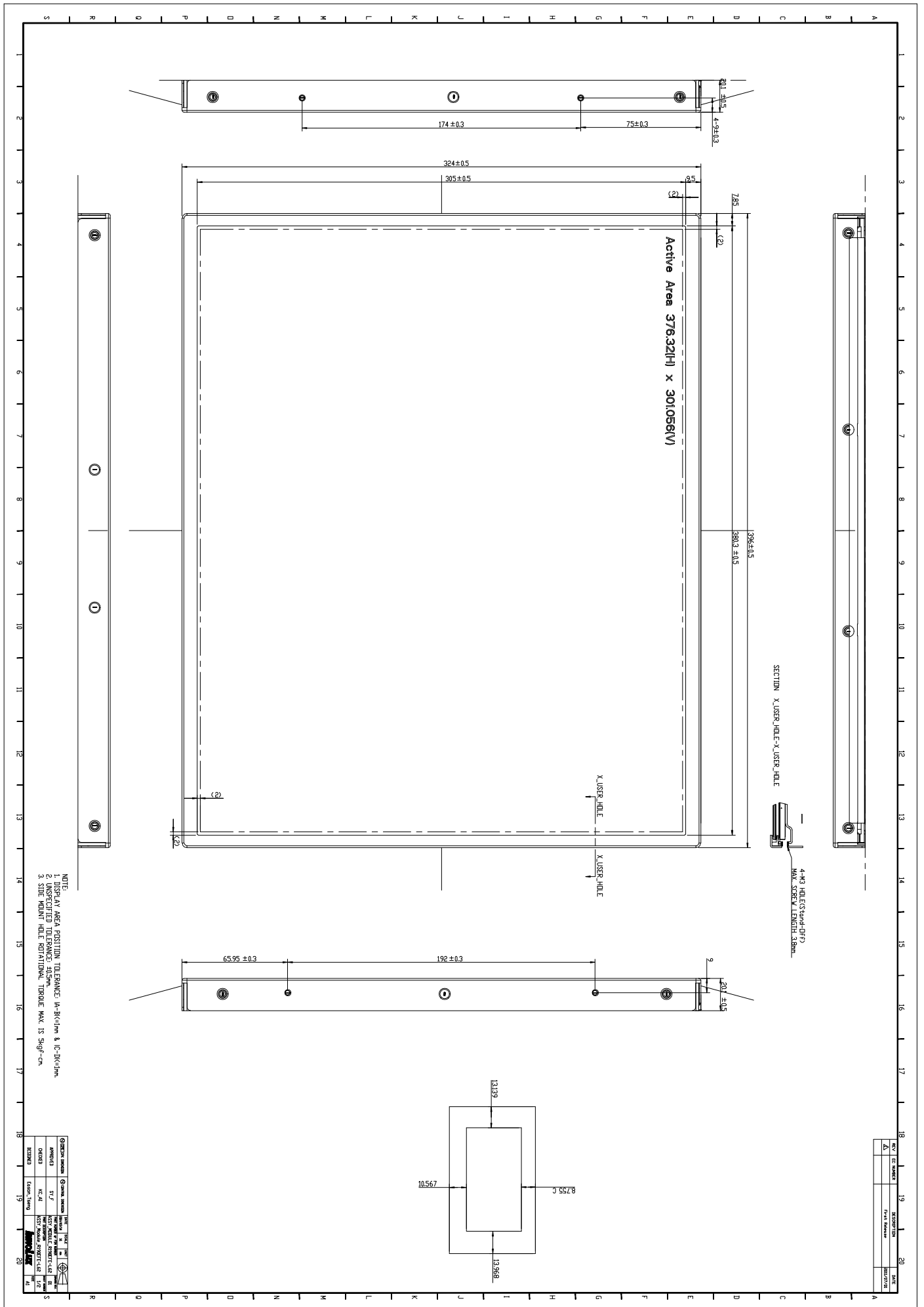

- NOTE:
1. DISPLAY AREA POSITION TOLERANCE: IN-BY-CHEM & IC-DIC-CHM
 2. UNSPECIFIED TOLERANCE: ±0.5mm
 3. SIDE MOUNT HOLE ROTATIONAL TOLERANCE: MAX. IS 90°±C°

QUANTITY	DESCRIPTION	UNIT	REMARKS
1	MONITOR	PC	ASST. MODEL: SHW77-142
1	MONITOR	PC	ASST. MODEL: SHW77-142
1	MONITOR	PC	ASST. MODEL: SHW77-142
1	MONITOR	PC	ASST. MODEL: SHW77-142
1	MONITOR	PC	ASST. MODEL: SHW77-142

REV.	DATE	DESCRIPTION	BY	CHK
Δ1		Final Review		

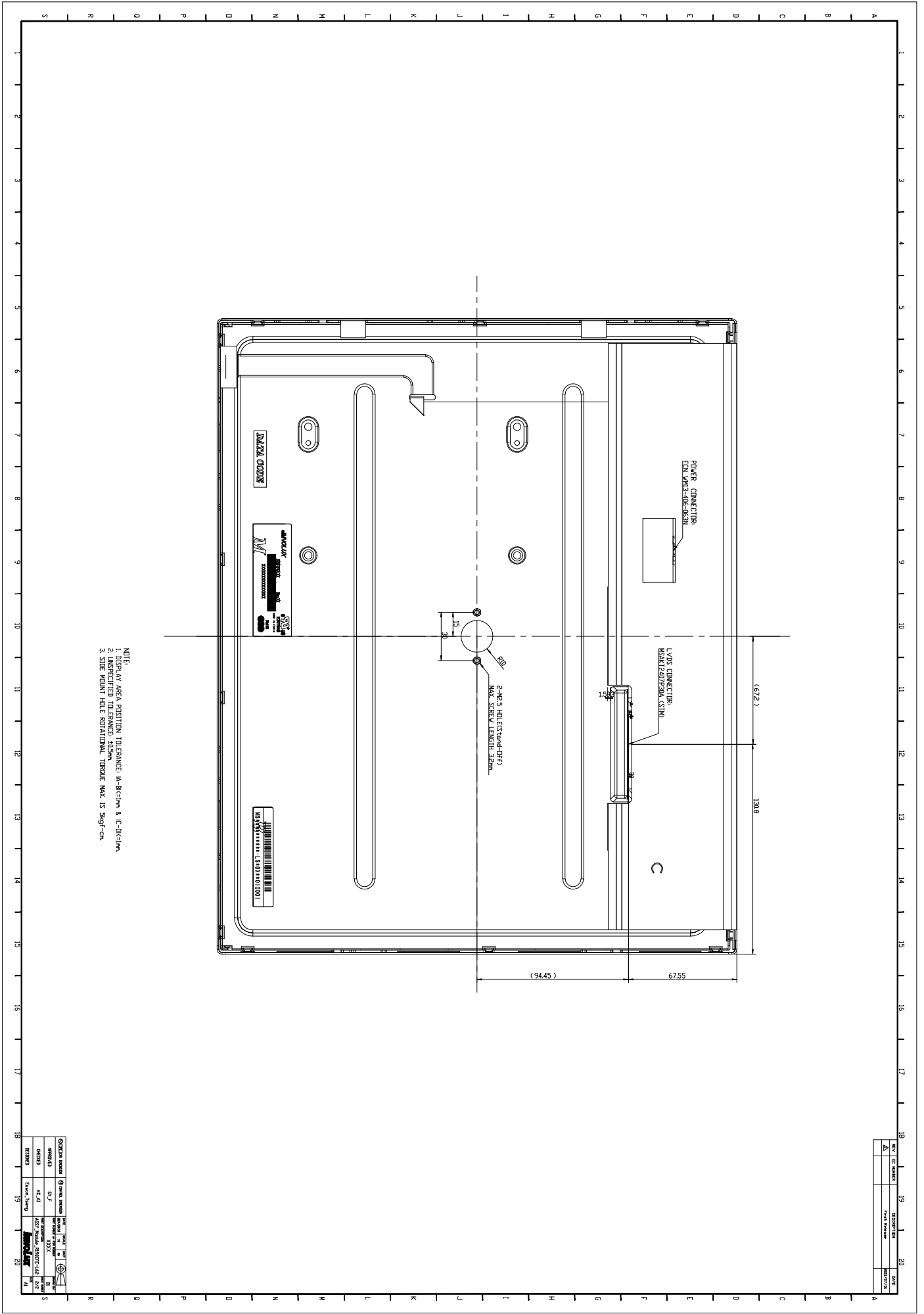

REV.	CC NUMBER	REVISION	DATE
Δ1		First Revision	08/07/20

QUANTITY	QUANTITY	UNIT	UNIT
AMOUNT	ST. J.	NO.	NO.
DRAWN	K.C. JI	DATE	DATE
REVISED	Exxon, Hong	REVISED	REVISED

DATA MODUL



ALL TECHNOLOGIES. ALL COMPETENCIES. ONE SPECIALIST.



DATA MODUL AG
Landsberger Straße 322
DE-80687 Munich
Phone: +49-89-56017-0

DATA MODUL WEIKERSHEIM GMBH
Lindenstraße 8
DE-97990 Weikersheim
Phone: +49-7934-101-0



More information and worldwide locations can be found at

www.data-modul.com