



SPECIFICATION

INNOLUX

S500DJ2-KS5

50" – UHD – V-by-One

Version: 2.1

Date: 17.11.2017

Note: This specification is subject to change without prior notice

- Tentative Specification
- Preliminary Specification
- Approval Specification

MODEL NO.: S500DJ2

SUFFIX: KS5

Revision : T1	
Customer :	
APPROVED BY	SIGNATURE
<u>Name / Title</u> _____	
Note	

Please return 1 copy for your confirmation with your signature and	

Approved By	Checked By	Prepared By
Roger Huang	ChihFan Ting	Anita Lai

CONTENTS

REVISION HISTORY	4
Modify 7.2 SAFETY PRECAUTIONS	4
1. GENERAL DESCRIPTION	5
1.1 OVERVIEW	5
1.2 FEATURES	5
1.3 GENERAL SPECIFICATIONS.....	5
1.4 MECHANICAL SPECIFICATIONS.....	6
2. ABSOLUTE MAXIMUM RATINGS	7
2.1 ABSOLUTE RATINGS OF ENVIRONMENT.....	7
Operating Range.....	7
Storage Range	7
2.2 PACKAGE STORAGE	8
2.3 ELECTRICAL ABSOLUTE RATINGS.....	8
2.3.1 TFT LCD MODULE	8
2.3.2 BACKLIGHT CONVERTER UNIT.....	8
3. ELECTRICAL CHARACTERISTICS.....	9
3.1 TFT LCD MODULE.....	9
3.2 BACKLIGHT UNIT	11
3.2.1 CONVERTER CHARACTERISTICS (Ta=25±2°C)	11
3.2.2 CONVERTER INTERFACE CHARACTERISTICS	13
4. INPUT TERMINAL PIN ASSIGNMENT.....	15
4.1 TFT LCD MODULE.....	15
4.2 BACKLIGHT UNIT	18
4.2.1 LIGHT BAR UNIT	18
4.2.2 CONVERTER UNIT	19
4.3 COLOR DATA INPUT ASSIGNMENT.....	20
5. INTERFACE TIMING.....	21
5.1 INPUT SIGNAL TIMING SPECIFICATIONS	21
5.1.1 Timing spec for QFHD Frame Rate = 50Hz	21
5.1.2 Timing spec for QFHD Frame Rate = 60Hz	21
5.2 Timing Diagram	24
5.2.1 V by One Input Signal Timing Diagram	24

5.3 Byte Length and Color mapping of V-by-One HS.....	25
5.4 POWER ON/OFF SEQUENCE	26
6. OPTICAL CHARACTERISTICS	28
6.1 TEST CONDITIONS	28
6.2 OPTICAL SPECIFICATIONS	29
7. PRECAUTIONS.....	32
7.1 ASSEMBLY AND HANDLING PRECAUTIONS.....	32
7.2 SAFETY PRECAUTIONS	33
7.3 SAFETY STANDARDS.....	34
8. DEFINITION OF LABELS	35
8.1 MODULE LABEL	35
8.2 CARTON LABEL.....	36
9. PACKAGING	37
9.1 PACKAGING SPECIFICATIONS.....	37
9.2 PACKAGING METHOD.....	37
9.3 UN-PACKAGING METHOD	38
10. MECHANICAL CHARACTERISTIC	39

REVISION HISTORY

Version	Date	Page (New)	Section	Description
Ver. 2.0	Oct.18,2017	All	All	Approval Specification was first issued.
	Nov.01,2017	39~42	10	Modify MECHANICAL CHARACTERISTIC
Ver.2.1	Nov.17,2017	33	7.2	Modify 7.2 SAFETY PRECAUTIONS

1. GENERAL DESCRIPTION

1.1 OVERVIEW

S500DJ2-KS5 is a 50" TFT Liquid Crystal Display PID module with LED Backlight unit and 8Lanes V-by-One HS interface. This module supports 3840 x 2160 Quad Full HDTV format and can display true 1.07G colors (8-bit+FRC). The converter module for backlight is built-in.

1.2 FEATURES

- High brightness 500 nits
- High contrast ratio 4000:1
- Fast response time Gray to Gray typical : 9.5 ms
- High color saturation NTSC 88%
- Quad Full HDTV (3840 x 2160 pixels) resolution, true HDTV format
- V-by-One HS interface
- Optimized response time for 50Hz/60Hz frame rate
- Viewing Angle : 178(H)/178(V) (CR>10) VA Technology
- Ultra wide viewing angle: Super MVA technology
- RoHs compliance
- T-con input frame rate * QFHD 50/60Hz,
Output frame rate: QFHD 50/60Hz

*: The detail setting such as I2C command or timing requirement in QFHD is specified in INX application note. It's important and necessary to follow the specification either in product SPEC or application note, otherwise it may lead to abnormal or no display. INX application note would be provided by INX in the design-in stage.

1.3 GENERAL SPECIFICATIONS

Item	Specification	Unit	Note
Active Area	1095.84(H) x 616.41(V) (50" diagonal)	mm	(1)
Bezel Opening Area	1100.04(H) x 620.41(V)	mm	
Driver Element	a-si TFT active matrix	-	-
Pixel Number	3840 x R.G.B. x 2160	pixel	-
Pixel Pitch(Sub Pixel)	0.0951(H) x 0.2854(V)	mm	-
Pixel Arrangement	RGB vertical stripe	-	-
Display Colors	1.07G colors (8-bit+FRC)	color	-
Display Operation Mode	Transmissive mode / Normally black	-	-
Surface Treatment	Anti-Glare coating (Haze ~1%) · Hardness 3H	-	(2)
Rotation Function	Unachievable		(3)
Display Orientation	Signal input with "INX"		(3)

Note (1) Please refer to the attached drawings in chapter 11 for more information about the front and back outlines.

Note (2) The spec of the surface treatment is temporarily for this phase. INX reserves the rights to change this feature.

Note (3)

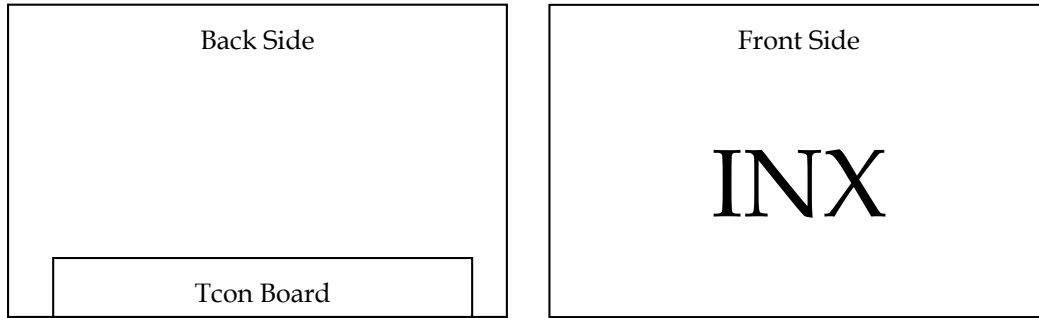

1.4 MECHANICAL SPECIFICATIONS

Item		Min.	Typ.	Max.	Unit	Note
Module Size	Horizontal (H)	1113.84	1115.04	1116.24	mm	(1),(2)
	Vertical (V)	637.21	638.41	639.61	mm	(1),(2)
	Depth (D)	10.5	11.5	12.5	mm	To Rear
		25.9	26.9	27.9	mm	To converter cover
Weight		-	11730	-	g	

Note (1) Please refer to the attached drawings for more information of front and back outline dimensions.

Note (2) Module Depth does not include connectors.

2. ABSOLUTE MAXIMUM RATINGS

2.1 ABSOLUTE RATINGS OF ENVIRONMENT

Item	Symbol	Value		Unit	Note
		Min.	Max.		
Storage Temperature	T _{ST}	-20	+60	°C	(1)
Operating Ambient Temperature	T _{OP}	0	50	°C	(1), (2)
Shock (Non-Operating)	S _{NOF}	-	35	G	(3), (5)
Vibration (Non-Operating)	V _{NOF}	-	1.0	G	(4), (5)

Note (1) Temperature and relative humidity range is shown in the figure below.

- (a) 90 %RH Max. ($T_a \leq 40$ °C).
- (b) Wet-bulb temperature should be 39 °C Max.
- (c) No condensation.

Note (2) Thermal management should be considered in final product design to prevent the surface temperature of display area from being over 65 °C. The range of operating temperature may degrade in case of improper thermal management in final product design.

Note (3) 11 ms, half sine wave, 1 time for ± X, ± Y, ± Z.

Note (4) 10 ~ 200 Hz, 30 min, 1 time each X, Y, Z.

Note (5) At testing Vibration and Shock, the fixture in holding the module has to be hard and rigid enough so that the module would not be twisted or bent by the fixture.

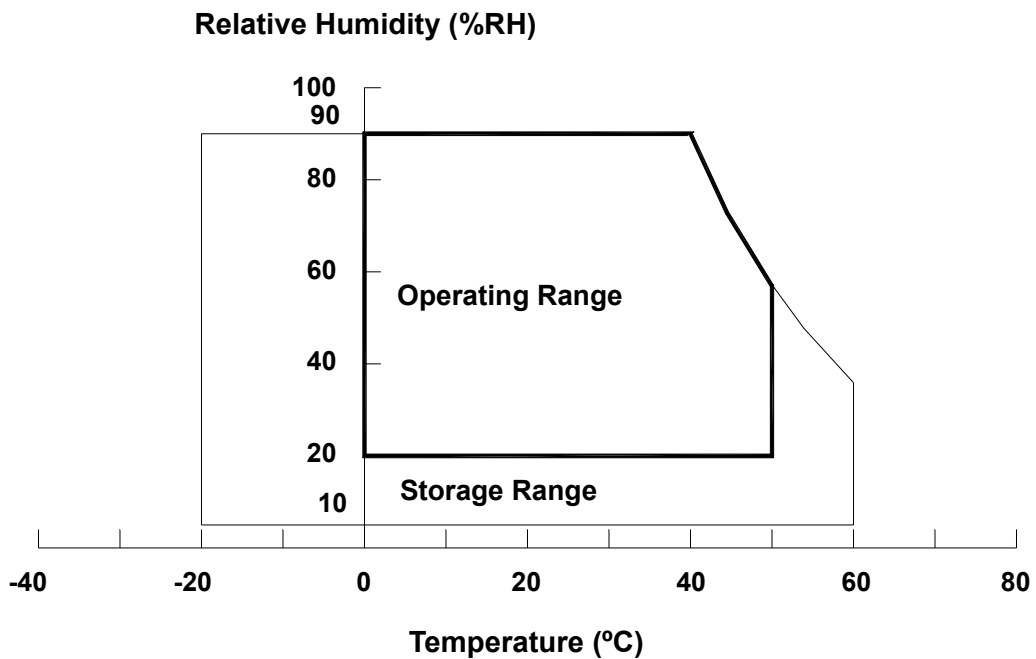

2.2 PACKAGE STORAGE

When storing modules as spares for a long time, the following precaution is necessary.

- (a) Do not leave the module in high temperature, and high humidity for a long time, It is highly recommended to store the module with temperature from 0 to 35 °C at normal humidity without condensation.
- (b) The module shall be stored in dark place. Do not store the TFT-LCD module in direct sunlight or fluorescent light.

2.3 ELECTRICAL ABSOLUTE RATINGS

2.3.1 TFT LCD MODULE

Item	Symbol	Value		Unit	Note
		Min.	Max.		
Power Supply Voltage	VCC	-0.3	13.5	V	(1)
Logic Input Voltage	VIN	-0.3	3.6	V	

Note (1) Permanent damage to the device may occur if maximum values are exceeded. Function operation should be restricted to the conditions described under Normal Operating Conditions.

2.3.2 BACKLIGHT CONVERTER UNIT

Item	Symbol	Test Condition	Min.	Type	Max.	Unit	Note
Light Bar Voltage	V _W	Ta = 25 °C	-	-	60	V _{RMS}	
Converter Input Voltage	V _{BL}	-	0	-	30	V	
Control Signal Level	-	-	-0.3	-	6	V	

Note (1) Permanent damage to the device may occur if maximum values are exceeded. Function operation should be restricted to the conditions described under Normal Operating Conditions.

Note (2) No moisture condensation or freezing.

Note (3) The control signals include On/Off Control and External PWM Control.

3. ELECTRICAL CHARACTERISTICS

3.1 TFT LCD MODULE

(Ta = 25 ± 2 °C)

Parameter		Symbol	Value			Unit	Note
			Min.	Typ.	Max.		
Power Supply Voltage		V _{CC}	10.8	12	13.2	V	(1)
Rush Current		I _{RUSH}	—	—	4	A	(2)
QFHD 60Hz Output Power Consumption	White Pattern	P _T	—	12.83	16.85	W	(3)
	Horizontal Stripe	P _T	—	27.32	36.29	W	
	Black Pattern	P _T	—	12.42	16.24	W	
QFHD 60Hz Output Power Supply Current	White Pattern	—	—	0.93	1.11	A	
	Horizontal Stripe	—	—	1.98	2.39	A	
	Black Pattern	—	—	0.90	1.07	A	
V-by-One HS	Differential Input High Threshold Voltage	VLVTH	—	—	+50	mV	
	Differential Input Low Threshold Voltage	VLVTL	-50	—	—	mV	
CMOS interface	Input High Threshold Voltage	V _{IH}	2.7	—	3.3	V	
	Input Low Threshold Voltage	V _{IL}	0	—	0.7	V	

Note (1) The module should be always operated within the above ranges. The ripple voltage should be controlled under 10% of V_{CC} (Typ.)

Note (2) Measurement condition :

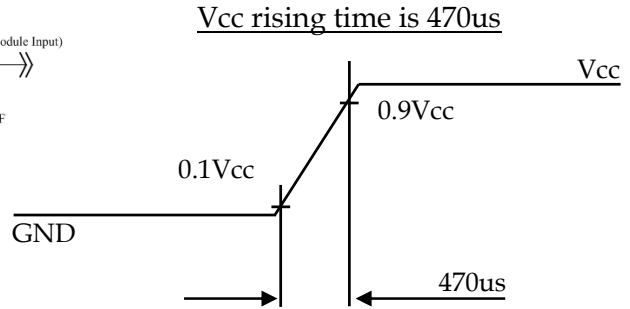
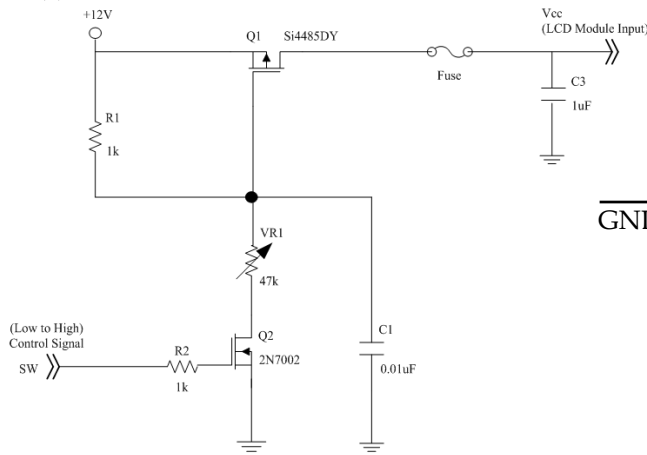

Note (3) The specified power supply current is under the conditions at $V_{cc} = 12\text{ V}$, $T_a = 25 \pm 2\text{ }^\circ\text{C}$, $f_v = 60\text{ Hz}$, whereas a power dissipation check pattern below is displayed.

a. White Pattern

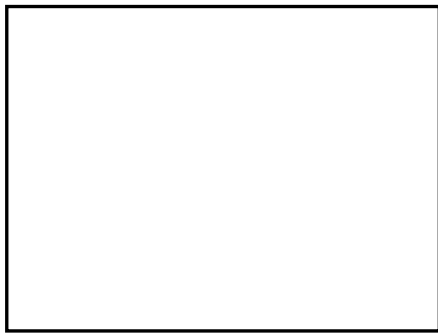

Active Area

b. Black Pattern



Active Area

c. Heavy Loading pattern

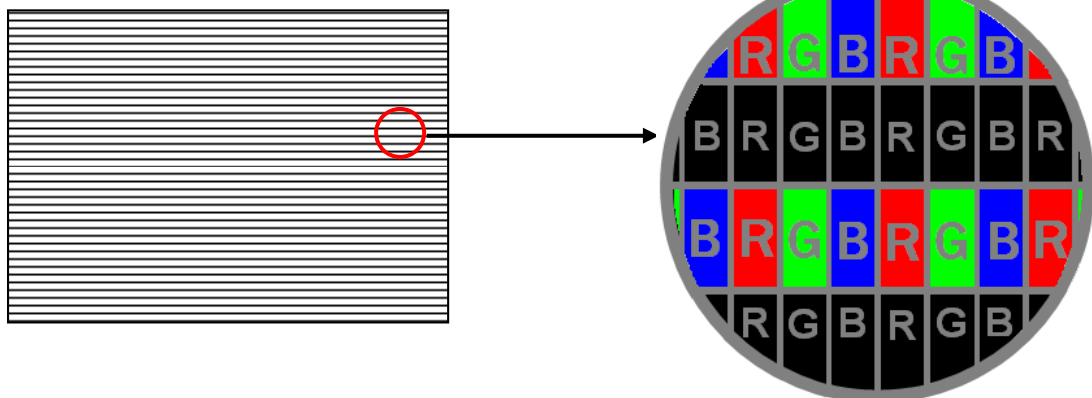

3.2 BACKLIGHT UNIT

3.2.1 CONVERTER CHARACTERISTICS (Ta=25±2°C)

Parameter	Symbol	Value			Unit	Note
		Min.	Typ.	Max.		
Power Consumption	P _{BL}	-	87.36	91.73	W	(1), (2)
Converter Input Voltage	V _{BL}	22.8	24.0	25.2	VDC	
Converter Input Current	I _{BL}	-	3.64	3.83	A	Non Dimming
Input Inrush Current	I _R	-	-	9	A _{peak}	V _{BL} =22.8V ₇ (3) (6)
Dimming Frequency	FB	150	160	170	Hz	(5)
Dimming Duty Ratio	DDR	5	-	100	%	(4) (5)
Life Time	-	30,000	-	-	Hrs	(7)

Note (1) The power supply capacity should be higher than the total converter power consumption PBL. Since the pulse width modulation (PWM) mode was applied for backlight dimming, the driving current changed as PWM duty on and off. The transient response of power supply should be considered for the changing loading when converter dimming.

Note (2) The measurement condition of Max. value is based on 50" backlight unit under input voltage 24V.

Note (3) For input inrush current measure, the VBL rising time from 10% to 90% is about 20ms.

Note (4) EPWM signal have to input available duty range. Between 97% and 100% duty (DDR) have to be avoided. (97% < DDR < 100%) But 100% duty (DDR) is possible. 5% duty (DDR) is only valid for electrical operation.

Note (5) FB and DDR are available only at 0D Mode.

Note (6) Below diagram is only for power supply design reference.

Test Condition : $V_{BL} = 22.8V$, $I_L = 200mA$ at OD mode

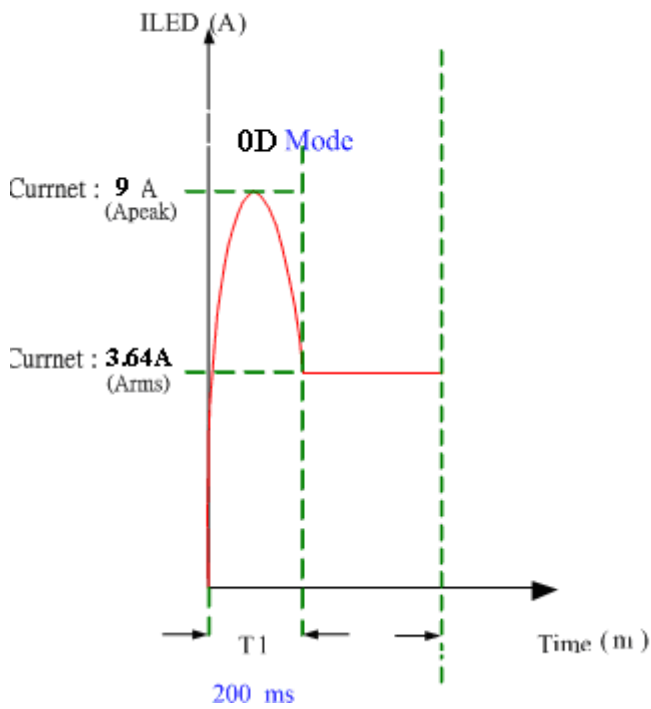

Note (7) The lifetime is defined as the time which luminance of the LED decays to 50% compared to the initial value,

Operating condition: Continuous operating at $T_a = 25 \pm 2^\circ C$

3.2.2 CONVERTER INTERFACE CHARACTERISTICS

Parameter	Symbol	Test Condition	Value			Unit	Note		
			Min.	Typ.	Max.				
On/Off Control Voltage	ON	VBLOW	—	2.0	—	5.0	V		
	OFF		—	0	—	0.8	V		
External PWM Control Voltage	HI	VEPWM	—	2.0	—	5.25	V	Duty on	(5), (6)
	LO		—	0	—	0.8	V	Duty off	
External PWM Frequency	F _{EPWM}	—	150	160	170	Hz	Normal mode (7)		
Error Signal	ERR	—	—	—	—	—	Abnormal: Open		
VBL Rising Time	Tr1	—	20	—	—	ms	10%-90%V _{BL}		
Control Signal Rising Time	Tr	—	—	—	100	ms			
Control Signal Falling Time	Tf	—	—	—	100	ms			
PWM Signal Rising Time	TPWMR	—	—	—	50	us	(6)		
PWM Signal Falling Time	TPWMF	—	—	—	50	us			
Input Impedance	Rin	—	1	—	—	MΩ	EPWM, BLON		
PWM Delay Time	TPWM	—	100	—	—	ms	(6)		
BLON Delay Time	T _{on}	—	300	—	—	ms			
	T _{on1}	—	300	—	—	ms			
BLON Off Time	Toff	—	300	—	—	ms			

Note (1) The Dimming signal should be valid before backlight turns on by BLON signal. It is inhibited to change the external PWM signal during backlight turn on period.

Note (2) The power sequence and control signal timing are shown in the Fig.1. For a certain reason, the converter has a possibility to be damaged with wrong power sequence and control signal timing.

Note (3) While system is turned ON or OFF, the power sequences must follow as below descriptions:

Turn ON sequence: VBL → PWM signal → BLON

Turn OFF sequence: BLOFF → PWM signal → VBL

Note (4) When converter protective function is triggered, ERR will output open collector status. Please refers to Fig.2.

Note (5) The EPWM interface that inserts a pull up resistor to 5V in Max Duty (100%), please refers to Fig.3.

Note (6) EPWM is available only at 2D Mode.

Note (7) EPWM signal have to input available frequency range.

Note (8) [Recommend] EPWM duty ratio is set at 100%(Max. Brightness) in 3D Mode.

Note (9) Used the EPWM signal control user dimming only in L/D OFF. When L/D ON. Please reference 5.1 Note (11) and application Note. [Common Model]

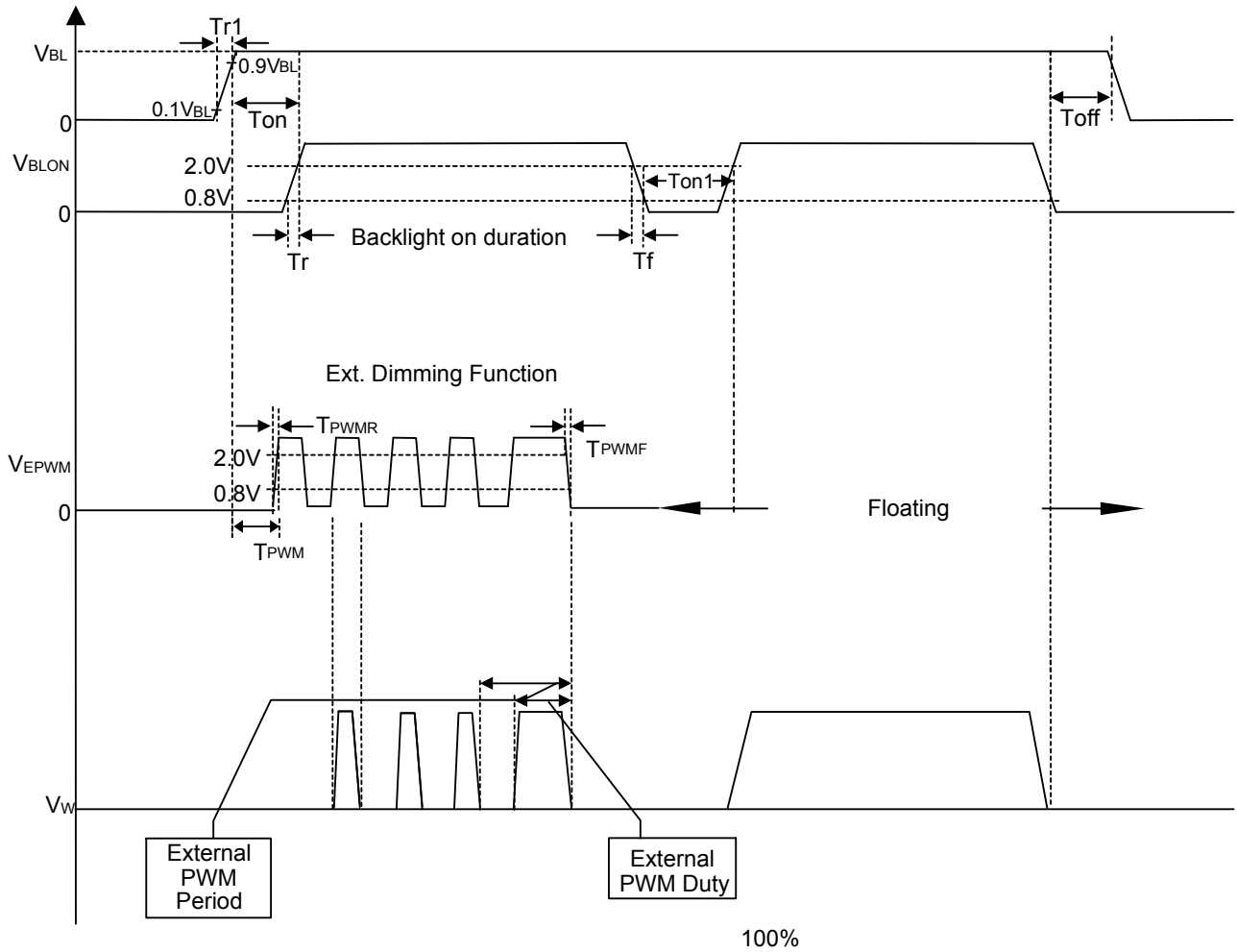

Fig. 1

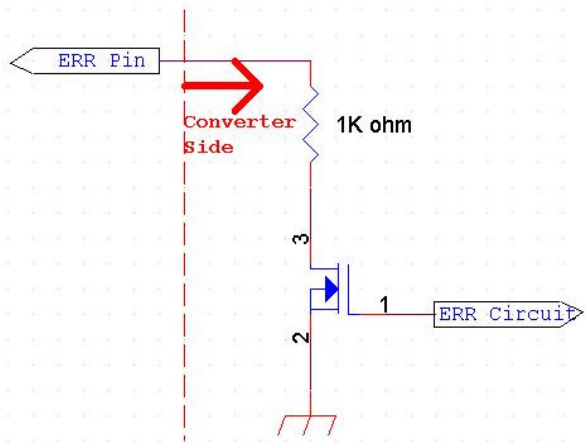

Fig. 2

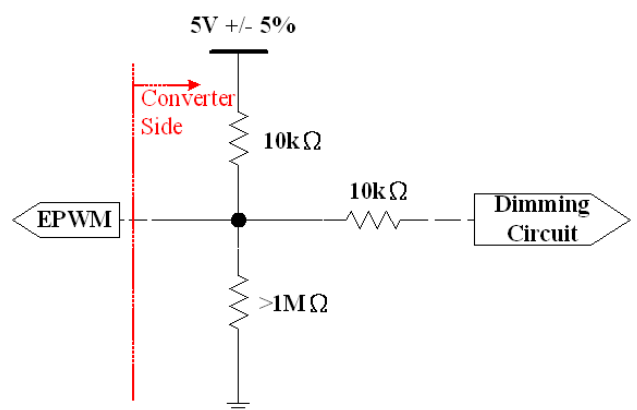

Fig. 3

4 .INPUT TERMINAL PIN ASSIGNMENT

4.1 TFT LCD MODULE

CNV1 Connector Pin Assignment: [187059-51221(P-TWO), WF23-402-5133(FCN)]

Matting Connector: [FI-RE51HL (JAE)]

Pin	Name	Description	Note
1	Vin	Power input (+12V)	
2	Vin	Power input (+12V)	
3	Vin	Power input (+12V)	
4	Vin	Power input (+12V)	
5	Vin	Power input (+12V)	
6	Vin	Power input (+12V)	
7	Vin	Power input (+12V)	
8	Vin	Power input (+12V)	
9	N.C.	No Connection	(4)
10	GND	Ground	
11	GND	Ground	
12	GND	Ground	
13	GND	Ground	
14	GND	Ground	
15	N.C.	No Connection	(4)
16	N.C.	No Connection	(4)
17	N.C.	No Connection	(4)
18	SDA	I2C Data signal	(5)
19	SCL	I2C Clock signal	(5)
20	WP	Write Protection (0V~0.7V/Open→Disable, 2.7V~3.3V→Enable) (for Auto-Vcom)	
21	N.C.	No Connection	(4)
22	N.C.	No Connection	(4)
23	N.C.	No Connection	(4)
24	N.C.	No Connection	(4)
25	HTPDN	Hot plug detect output, Open drain.	
26	LOCKN	Lock detect output, Open drain.	
27	GND	Ground	
28	RX0N	1 ST Pixel Negative V-by-One differential data input in area A. Lane 0	(1)
29	RX0P	1 ST Pixel Positive V-by-One differential data input in area A. Lane 0	
30	GND	Ground	
31	RX1N	2 ND Pixel Negative V-by-One differential data input in area A. Lane 1	(1)

32	RX1P	2 ND Pixel Positive V-by-One differential data input in area A. Lane 1	
33	GND	Ground	
34	RX2N	3 RD Pixel Negative V-by-One differential data input in area A. Lane 2	(1)
35	RX2P	3 RD Pixel Positive V-by-One differential data input in area A. Lane 2	
36	GND	Ground	
37	RX3N	4 TH Pixel Negative V-by-One differential data input in area A. Lane 3	(1)
38	RX3P	4 TH Pixel Positive V-by-One differential data input in area A. Lane 3	
39	GND	Ground	
40	RX4N	5 TH Pixel Negative V-by-One differential data input in area A. Lane 4	(1)
41	RX4P	5 TH Pixel Positive V-by-One differential data input in area A. Lane 4	
42	GND	Ground	
43	RX5N	6 TH Pixel Negative V-by-One differential data input in area A. Lane 5	(1)
44	RX5P	6 TH Pixel Positive V-by-One differential data input in area A. Lane 5	
45	GND	Ground	
46	RX6N	7 TH Pixel Negative V-by-One differential data input in area A. Lane 6	(1)
47	RX6P	7 TH Pixel Positive V-by-One differential data input in area A. Lane 6	
48	GND	Ground	
49	RX7N	8 TH Pixel Negative V-by-One differential data input in area A. Lane 7	(1)
50	RX7P	8 TH Pixel Positive V-by-One differential data input in area A. Lane 7	
51	GND	Ground	

Note (1) V-by-One^R HS Data Mapping

Area	Lane	Data Stream
A	Lane 0	1, 9, 17,, 3825, 3833
	Lane 1	2, 10, 18,, 3826, 3834
	Lane 2	3, 11, 19,, 3827, 3835
	Lane 3	4, 12, 20,, 3828, 3836
	Lane 4	5, 13, 21,, 3829, 3837
	Lane 5	6, 14, 22,, 3830, 3838
	Lane 6	7, 15, 23,, 3831, 3839
	Lane 7	8, 16, 24,, 3832, 3840

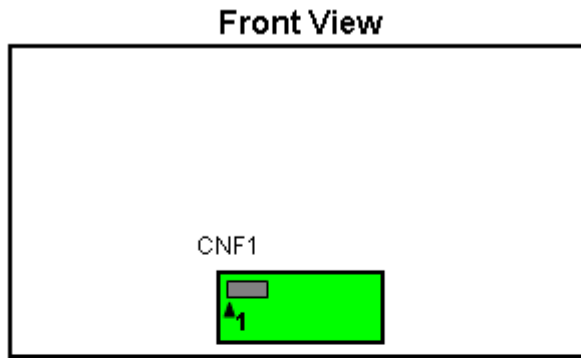

Data Lane 0	A
Data Lane 1	
Data Lane 2	
Data Lane 3	
Data Lane 4	
Data Lane 5	
Data Lane 6	
Data Lane 7	

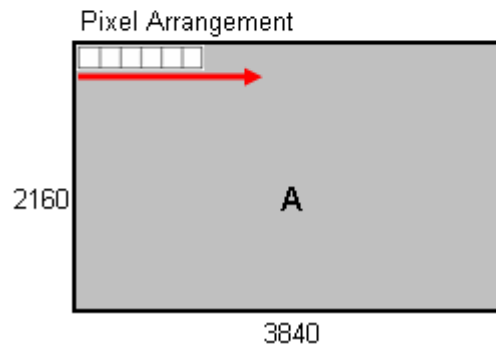
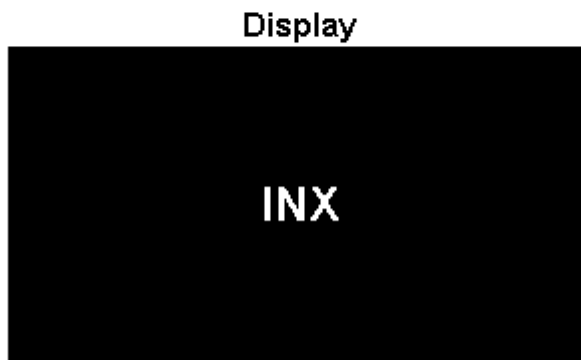

Note (2) V-by-One HS connector pin order defined as follows

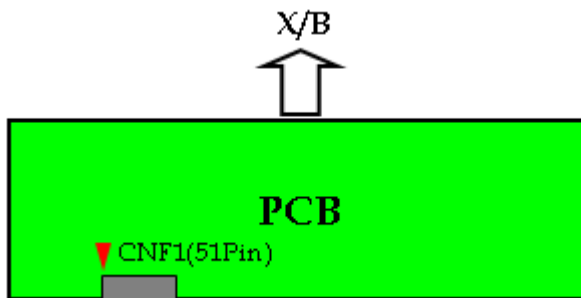

Note (3) V-by-One connector mating dimension range request is 0.93mm~1.0mm as below

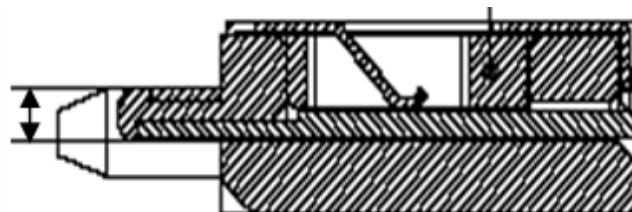

Note (4) Reserved for internal use. Please leave it open.

Note (5) The detail setting such as I2C command or timing requirement in QFHD is specified in INX application note. It's important and necessary to follow the specification either in product SPEC or application note, otherwise it may lead to abnormal or no display. INX application note would be provided by INX in the design-in stage.

4.2 BACKLIGHT UNIT

4.2.1 LIGHT BAR UNIT

The pin configuration for the housing and the lead wire is shown in the table below.

CN3 & CN6

Connector Type : JH2-D4-123N(FCN) or CI0112M1HR0-LA(Cvilux)

Pin No.	Symbol	Description
1	N-	Negative of LED string
2	N-	
3	N-	
4	N-	
5	N-	NC
6	N-	NC
7	NC	NC
8	NC	NC
9	NC	NC
10	NC	NC
11	VLED+	Positive of LED string
12	VLED+	

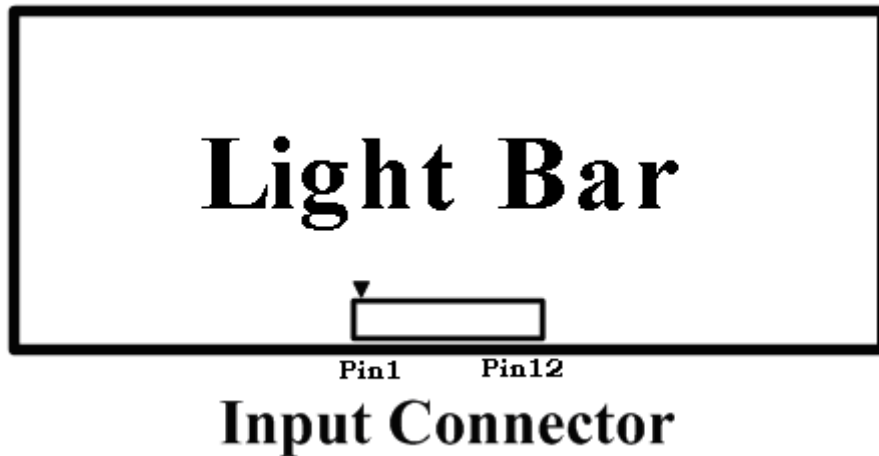

4.2.2 CONVERTER UNIT

CN1 Connector Pin Assignment:: CI0114M1HR0-LA (CvilLux) or JH2-D4-143N (FCN)

Pin No	Symbol	Feature
1	VBL	+24V
2		
3		
4		
5		
6	GND	GND
7		
8		
9		
10		
11	ERR	Normal (GND) Abnormal (Open collector)
12	BLON	BL ON/OFF
13	NC	NC
14	E_PWM	External PWM Control

Note (1) If Pin14 is open, E_PWM is 100% duty.

Note (2) Input connector pin order defined as follows

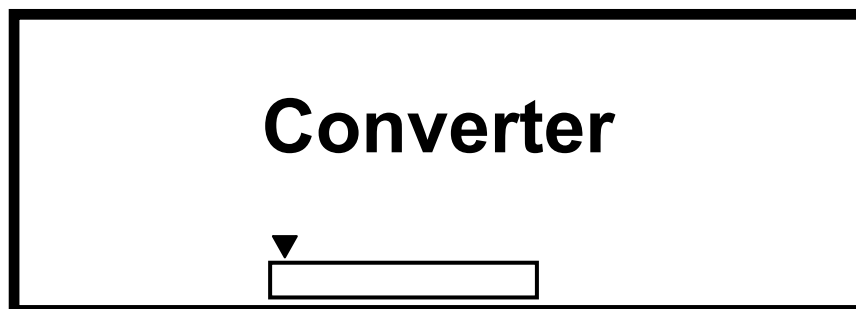

Pin 1

Pin 14

Input Connector

4.3 COLOR DATA INPUT ASSIGNMENT

The brightness of each primary color (red, green and blue) is based on the 10-bit gray scale data input for the color. The higher the binary input the brighter the color. The table below provides the assignment of color versus data input.

Color		Data Signal																											
		Red										Green										Blue							
		R9	R8	R7	R6	R5	R4	R3	R2	R1	R0	G9	G8	G7	G6	G5	G4	G3	G2	G1	G0	B9	B8	B7	B6	B5	B4	B3	B2
Basic Colors	Black	0	0	0	0	0	0	0	0	0	0	0	0	0	0	0	0	0	0	0	0	0	0	0	0	0	0	0	0
	Red	1	1	1	1	1	1	1	1	1	1	0	0	0	0	0	0	0	0	0	0	0	0	0	0	0	0	0	0
	Green	0	0	0	0	0	0	0	0	0	0	1	1	1	1	1	1	1	1	1	1	0	0	0	0	0	0	0	0
	Blue	0	0	0	0	0	0	0	0	0	0	0	0	0	0	0	0	0	0	0	0	1	1	1	1	1	1	1	1
	Cyan	0	0	0	0	0	0	0	0	0	0	1	1	1	1	1	1	1	1	1	1	1	1	1	1	1	1	1	1
	Magenta	1	1	1	1	1	1	1	1	1	1	0	0	0	0	0	0	0	0	0	0	1	1	1	1	1	1	1	1
	Yellow	1	1	1	1	1	1	1	1	1	1	1	1	1	1	1	1	1	1	1	1	0	0	0	0	0	0	0	0
	White	1	1	1	1	1	1	1	1	1	1	1	1	1	1	1	1	1	1	1	1	1	1	1	1	1	1	1	1
Gray Scale Of Red	Red (0) / Dark	0	0	0	0	0	0	0	0	0	0	0	0	0	0	0	0	0	0	0	0	0	0	0	0	0	0	0	
	Red (1)	0	0	0	0	0	0	0	0	1	0	0	0	0	0	0	0	0	0	0	0	0	0	0	0	0	0	0	
	Red (2)	0	0	0	0	0	0	0	0	1	0	0	0	0	0	0	0	0	0	0	0	0	0	0	0	0	0	0	
	:	:	:	:	:	:	:	:	:	:	:	:	:	:	:	:	:	:	:	:	:	:	:	:	:	:	:	:	
	:	:	:	:	:	:	:	:	:	:	:	:	:	:	:	:	:	:	:	:	:	:	:	:	:	:	:	:	
	:	:	:	:	:	:	:	:	:	:	:	:	:	:	:	:	:	:	:	:	:	:	:	:	:	:	:	:	
	Red (1021)	1	1	1	1	1	1	1	1	0	1	0	0	0	0	0	0	0	0	0	0	0	0	0	0	0	0	0	
	Red (1022)	1	1	1	1	1	1	1	1	1	0	0	0	0	0	0	0	0	0	0	0	0	0	0	0	0	0	0	
Red (1023)	1	1	1	1	1	1	1	1	1	1	0	0	0	0	0	0	0	0	0	0	0	0	0	0	0	0	0		
Gray Scale Of Green	Green (0) / Dark	0	0	0	0	0	0	0	0	0	0	0	0	0	0	0	0	0	0	0	0	0	0	0	0	0	0	0	
	Green (1)	0	0	0	0	0	0	0	0	0	0	0	0	0	0	0	0	0	0	0	1	0	0	0	0	0	0	0	
	Green (2)	0	0	0	0	0	0	0	0	0	0	0	0	0	0	0	0	0	0	1	0	0	0	0	0	0	0	0	
	:	:	:	:	:	:	:	:	:	:	:	:	:	:	:	:	:	:	:	:	:	:	:	:	:	:	:	:	
	:	:	:	:	:	:	:	:	:	:	:	:	:	:	:	:	:	:	:	:	:	:	:	:	:	:	:	:	
	:	:	:	:	:	:	:	:	:	:	:	:	:	:	:	:	:	:	:	:	:	:	:	:	:	:	:	:	
	Green (1021)	0	0	0	0	0	0	0	0	0	1	1	1	1	1	1	1	1	1	0	1	0	0	0	0	0	0	0	
	Green (1022)	0	0	0	0	0	0	0	0	0	1	1	1	1	1	1	1	1	1	0	0	0	0	0	0	0	0	0	
Green (1023)	0	0	0	0	0	0	0	0	0	1	1	1	1	1	1	1	1	1	1	0	0	0	0	0	0	0	0		
Gray Scale Of Blue	Blue (0) / Dark	0	0	0	0	0	0	0	0	0	0	0	0	0	0	0	0	0	0	0	0	0	0	0	0	0	0	0	
	Blue (1)	0	0	0	0	0	0	0	0	0	0	0	0	0	0	0	0	0	0	0	0	0	0	0	0	0	0	1	
	Blue (2)	0	0	0	0	0	0	0	0	0	0	0	0	0	0	0	0	0	0	0	0	0	0	0	0	0	0	1	
	:	:	:	:	:	:	:	:	:	:	:	:	:	:	:	:	:	:	:	:	:	:	:	:	:	:	:	:	
	:	:	:	:	:	:	:	:	:	:	:	:	:	:	:	:	:	:	:	:	:	:	:	:	:	:	:	:	
	:	:	:	:	:	:	:	:	:	:	:	:	:	:	:	:	:	:	:	:	:	:	:	:	:	:	:	:	
	Blue (1021)	0	0	0	0	0	0	0	0	0	0	0	0	0	0	0	0	0	0	0	1	1	1	1	1	1	1	0	
	Blue (1022)	0	0	0	0	0	0	0	0	0	0	0	0	0	0	0	0	0	0	0	1	1	1	1	1	1	1	0	
Blue (1023)	0	0	0	0	0	0	0	0	0	0	0	0	0	0	0	0	0	0	0	1	1	1	1	1	1	1	0		

Note (1) 0: Low Level Voltage , 1: High Level Voltage

5. INTERFACE TIMING

5.1 INPUT SIGNAL TIMING SPECIFICATIONS

The input signal timing specifications are shown as the following table and timing diagram. ($T_a = 25 \pm 2^\circ\text{C}$)

Signal	Item	Symbol	Min.	Typ.	Max.	Unit	Note
Frequency	Data Clock	1/Tc	69	74.25	79	MHZ	(1)
V-by-One Receiver	Intra-Pair skew		-0.3	—	0.3	UI	(2)
	Inter-pair skew		-5	—	5	UI	(3)
	Spread spectrum modulation range	Felkin_mod	1/Tc-0.5%	—	1/Tc+0.5%	MHz	(4)
	Spread spectrum modulation frequency	F _{SSM}	—	—	30	KHz	

5.1.1 Timing spec for QFHD Frame Rate = 50Hz

Signal	Item	Symbol	Min.	Typ.	Max.	Unit	Note	
Frame rate	2D mode	Fr	49	50	51	Hz	(5),(6)	
Vertical Active Display Term (8 Lane,3840X2160 Active Area)	2D Mode	Total	Tv	2200	2700	2790	Th	Tv=Tvd+Tvb
		Display	Tvd	2160			Th	
		Blank	Tvb	40	540	630	Th	
Horizontal Active Display Term (8 Lane,3840X2160 Active Area)	2D Mode	Total	Th	530	550	590	Tc	Th=Thd+Thb
		Display	Thd	480			Tc	
		Blank	Thb	50	70	110	Tc	

5.1.2 Timing spec for QFHD Frame Rate = 60Hz

Signal	Item	Symbol	Min.	Typ.	Max.	Unit	Note	
Frame Rate	2D Mode	F _r	59	60	61	Hz	(5),(6)	
Vertical Active Display Term (8 Lane,3840X2160 Active Area)	2D Mode	Total	Tv	2230	2250	2350	Th	Tv=Tvd+Tvb
		Display	Tvd	2160			Th	
		Blank	Tvb	70	90	190	Th	
Horizontal Active Display Term	2D Mode	Total	Th	530	550	600	Tc	Th=Thd+Thb
		Display	Thd	480			Tc	

(8 Lane, 3840X2160 Active Area)		Blank	Thb	50	70	120	Tc	
------------------------------------	--	-------	-----	----	----	-----	----	--

Note (1) Please make sure the range of pixel clock has follow the below equation :

$$F_{clk}(max) \geq Fr \times Tv \times Th$$

$$Fr \times Tv \times Th \geq F_{clk}(min)$$

INPUT SIGNAL TIMING DIAGRAM

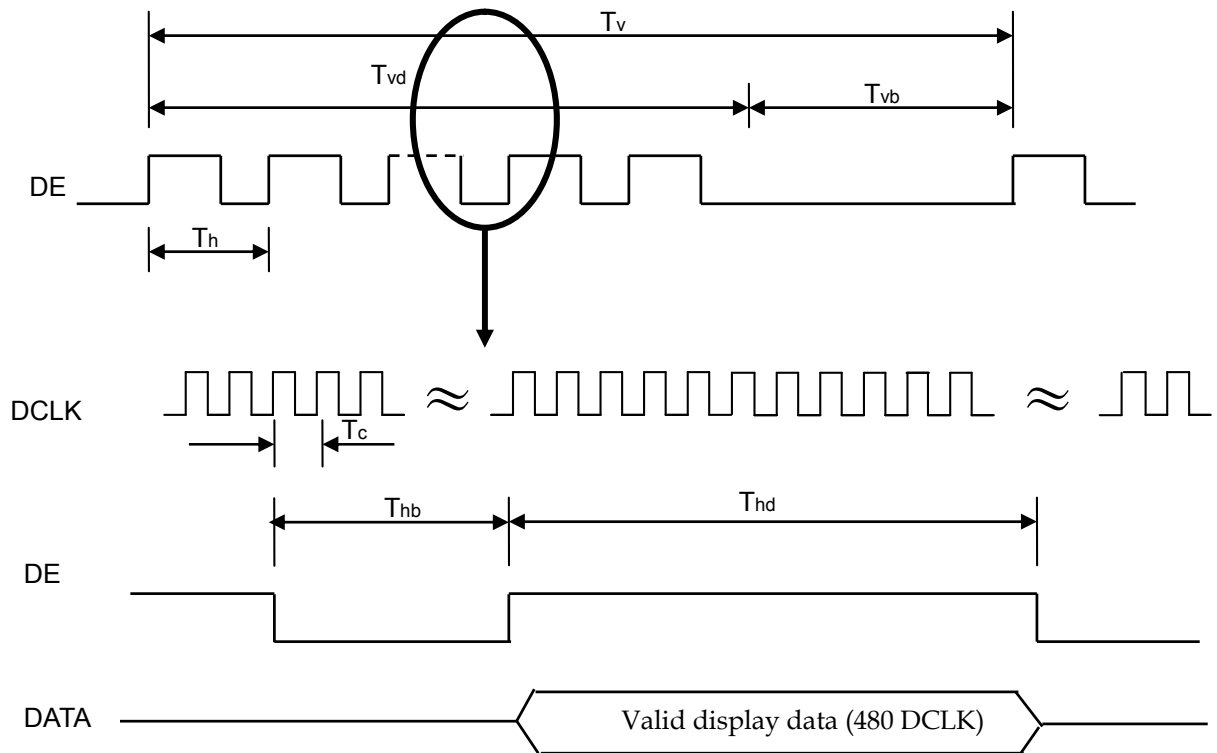

Note (2) Intra-pair Data skew

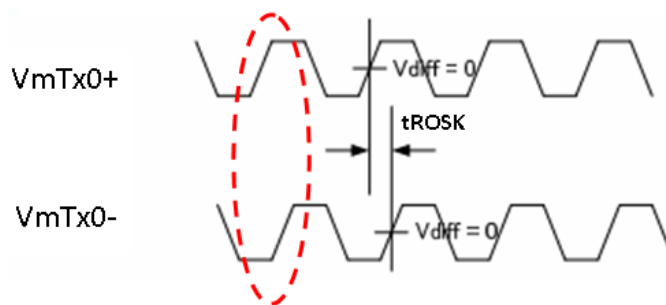

The same pair signal

Note (3) V-by-One HS Inter-pair skew.

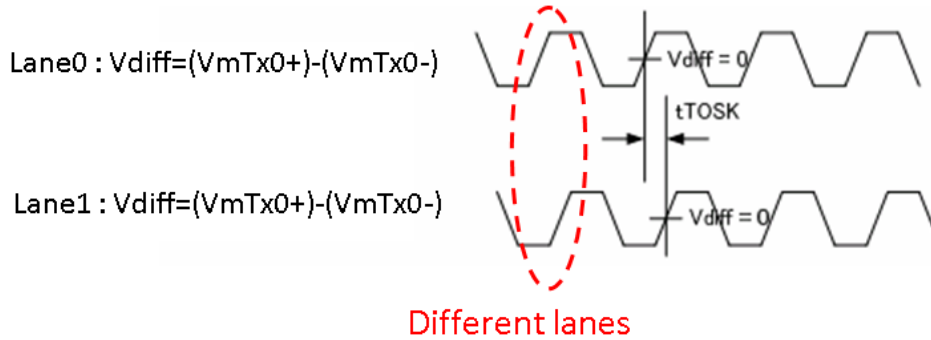

Note (4) The SSCG (Spread spectrum clock generator) is defined as below figures.

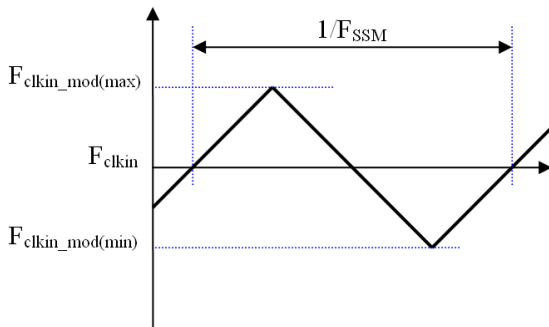

Note (5) The frame-to-frame jitter of the input frame rate is defined as the above figures. $FR_n = FR_{n-1} \pm 0.62\%$.

Note (6) The setup of the frame rate jitter > 0.62% may result in incorrect timing mode and panel cosmetic symptom..

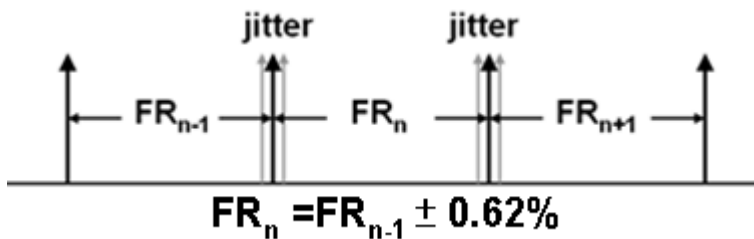

5.2 Timing Diagram

5.2.1 V by One Input Signal Timing Diagram

The eye diagram is measured by the oscilloscope and receiver CDR characteristic must be emulated.

PLL bandwidth : 8MHz

Damping facto : 0.707

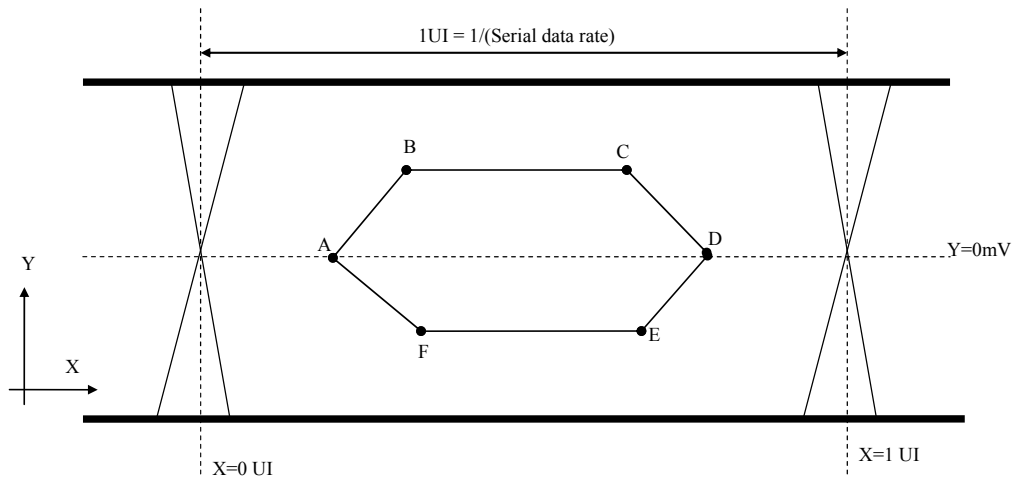

Table 1 Eye Mask Specification

	X [UI]	Y [mV]	Note
A	0.25	0	(1)
B	0.3	50	(1)
C	0.7	50	(1)
D	0.75	0	(1)
E	0.7	-50	(1)
F	0.3	-50	(1)

Note (1) Input levels of V-by-One HS signals are comes from "V-by-One HS Stander Ver.1.4"

5.3 Byte Length and Color mapping of V-by-One HS

Packer input & Unpacker output		30bpp RGB (10bit)
Byte 0	D[0]	R[2]
	D[1]	R[3]
	D[2]	R[4]
	D[3]	R[5]
	D[4]	R[6]
	D[5]	R[7]
	D[6]	R[8]
	D[7]	R[9]
Byte 1	D[8]	G[2]
	D[9]	G[3]
	D[10]	G[4]
	D[11]	G[5]
	D[12]	G[6]
	D[13]	G[7]
	D[14]	G[8]
	D[15]	G[9]
Byte 2	D[16]	B[2]
	D[17]	B[3]
	D[18]	B[4]
	D[19]	B[5]
	D[20]	B[6]
	D[21]	B[7]
	D[22]	B[8]
	D[23]	B[9]
Byte 3	D[24]	X
	D[25]	X
	D[26]	B[0]
	D[27]	B[1]
	D[28]	G[0]
	D[29]	G[1]
	D[30]	R[0]
	D[31]	R[1]

5.4 POWER ON/OFF SEQUENCE

($T_a = 25 \pm 2^\circ\text{C}$)

To prevent a latch-up or DC operation of LCD module, the power on/off sequence should be as the diagram below.

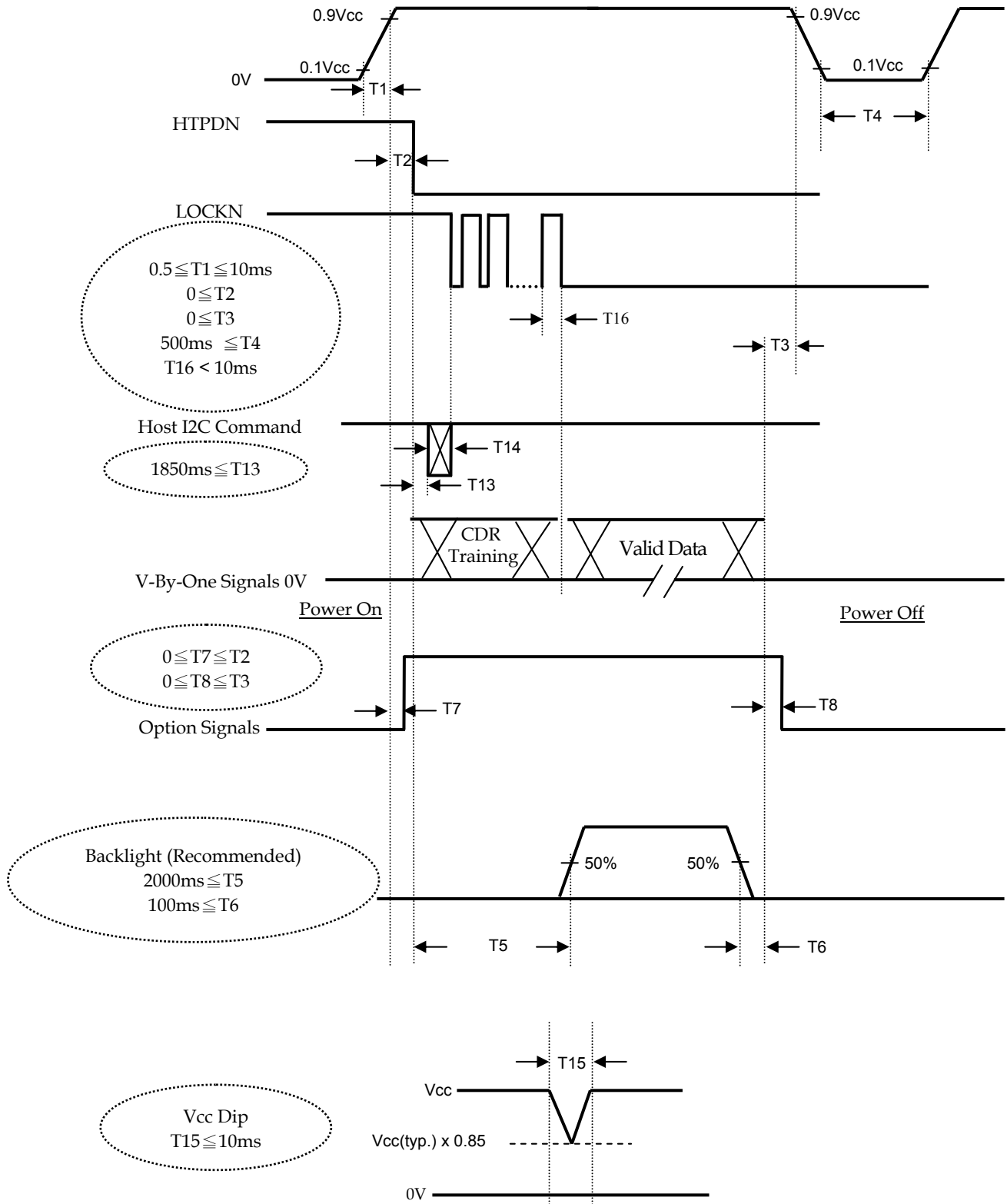

- Note (1) The supply voltage of the external system for the module input should follow the definition of Vcc.
- Note (2) Apply the LED voltage within the LCD operation range. When the backlight turns on before the LCD operation or the LCD turns off before the backlight turns off, the display may momentarily become abnormal screen.
- Note (3) In case of Vcc is in off level, please keep the level of input signals on the low or high impedance. If $T2 < 0$, that maybe cause electrical overstress failure.
- Note (4) T4 should be measured after the module has been fully discharged between power off and on period.
- Note (5) Interface signal shall not be kept at high impedance when the power is on.
- Note (6) Vcc must decay smoothly when power-off.
- Note (7) $T5 > (T13 + T14)$
- Note (8) T16, V-by-One signals shall be stabilized and follows timing specification which defined by section 6.1 & 6.2.

6. OPTICAL CHARACTERISTICS

6.1 TEST CONDITIONS

Item	Symbol	Value	Unit
Ambient Temperature	Ta	25±2	°C
Ambient Humidity	Ha	50±10	%RH
Supply Voltage	V _{CC}	12±1.2	V
Input Signal	According to typical value in "3. ELECTRICAL CHARACTERISTICS"		
Vertical Frame Rate	Fr	60	Hz

The LCD module should be stabilized at given temperature for 1 hour to avoid abrupt temperature change during measuring in a windless room.

Local Dimming Function should be Disable before testing to get the steady optical characteristics (According to 5.1 CNF1 Connector Pin Assignment, Pin no. "42")

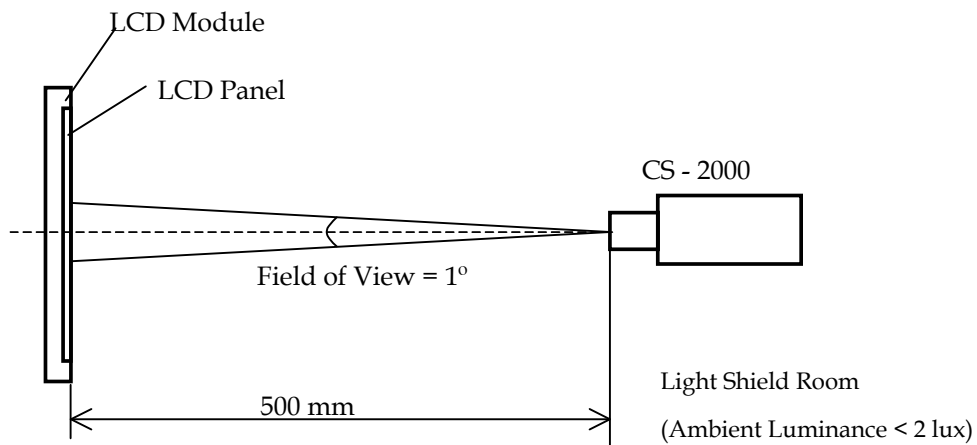

6.2 OPTICAL SPECIFICATIONS

The relative measurement methods of optical characteristics are shown in 7.2. The following items should be measured under the test conditions described in 7.1 and stable environment shown in 7.1.

Item		Symbol	Condition	Min.	Typ.	Max.	Unit	Note				
Contrast Ratio		CR	$\theta_x=0^\circ, \theta_y=0^\circ$ Viewing angle at normal direction	2800	4000	-	-	Note (2)				
Response Time		Gray to gray			9.5	19	ms	Note (3)				
Center Luminance of White		L_C		400	500	-	cd/m ²	Note (4)				
White Variation		δW				1.3	-	Note (6)				
Cross Talk		CT		-		4	%	Note (5)				
Color Chromaticity	Red	R_x		$\theta_x=0^\circ, \theta_y=0^\circ$ Viewing angle at normal direction	Typ.- 0.03	0.670	Typ.+ 0.03	-				
		R_y				0.310		-				
	Green	G_x				0.270		-				
		G_y				0.650		-				
	Blue	B_x				0.152		-				
		B_y	0.055			-						
	White	W_x	0.280			-						
		W_y	0.290			-						
	Correlated color temperature					10000					K	
	Color Gamut		C.G.			-		88		-	%	NTSC
Viewing Angle	Horizontal	θ_{x+}	CR \geq 10	80	89	-	Deg.	(1)				
		θ_{x-}		80	89	-						
	Vertical	θ_{y+}		80	89	-						
		θ_{y-}		80	89	-						

Note (1) Definition of Viewing Angle (θ_x, θ_y) :

Viewing angles are measured by Autronic Conoscope Cono-80 (or Eldim EZ-Contrast 160R).

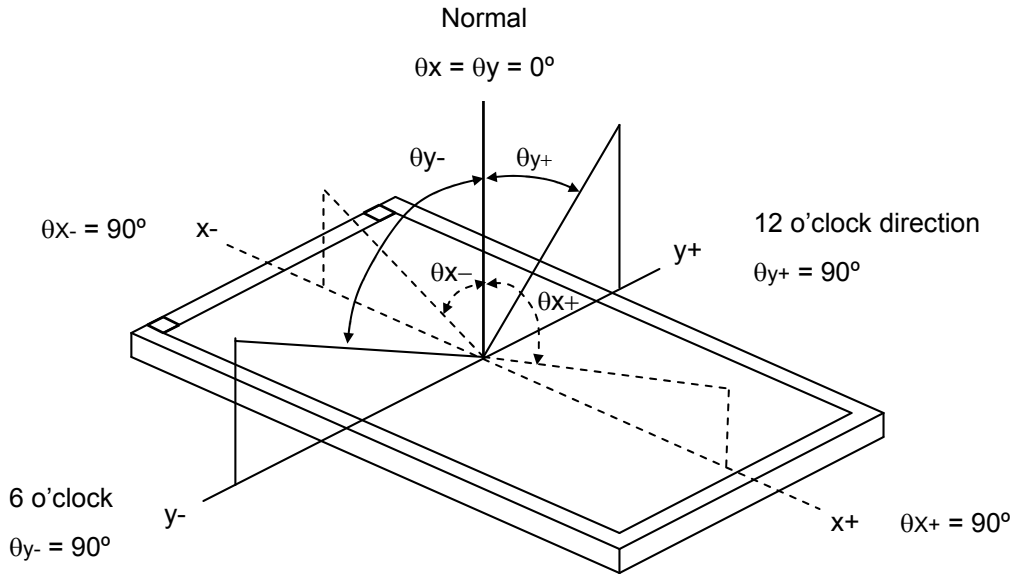

Note (2) Definition of Contrast Ratio (CR) :

The contrast ratio can be calculated by the following expression.

$$\text{Contrast Ratio (CR)} = \frac{\text{Surface Luminance of L1023}}{\text{Surface Luminance of L0}}$$

L1023: Luminance of gray level 1023

L 0: Luminance of gray level 0

CR = CR (X), where CR (X) is corresponding to the Contrast Ratio of the point X at the figure in Note (6).

Note (3) Definition of Gray-to-Gray Switching Time :

Optical Response

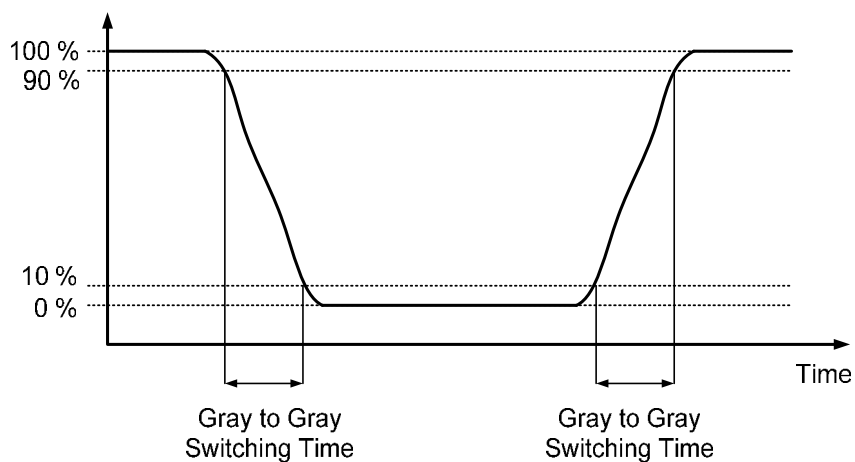

The driving signal means the signal of gray level 0, 124, 252, 380, 508, 636, 764, 892 and 1023.

Gray to gray average time means the average switching time of gray level 0, 124, 252, 380, 508, 636, 764, 892 and 1023 to each other.

Note (4) Definition of Luminance of White (L_C) :

Measure the luminance of gray level 1023 at center point.

$L_C = L(5)$, where $L(x)$ is corresponding to the luminance of the point X at the figure in Note (6).

Note (5) Definition of Cross Talk (CT) :

$$CT = | Y_B - Y_A | / Y_A \times 100 (\%)$$

Where :

Y_A = Luminance of measured location without gray level 1023 pattern (cd/m²)

Y_B = Luminance of measured location with gray level 1023 pattern (cd/m²)

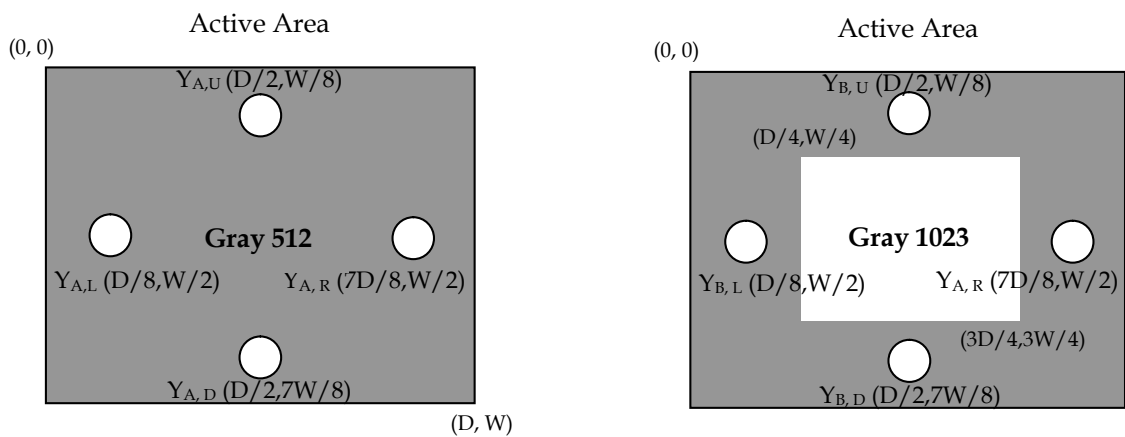

Note (6) Definition of White Variation (δW):

Measure the luminance of gray level 1023 at 5 points

$$\delta W = \frac{\text{Maximum} [L(1), L(2), L(3), L(4), L(5)]}{\text{Minimum} [L(1), L(2), L(3), L(4), L(5)]}$$

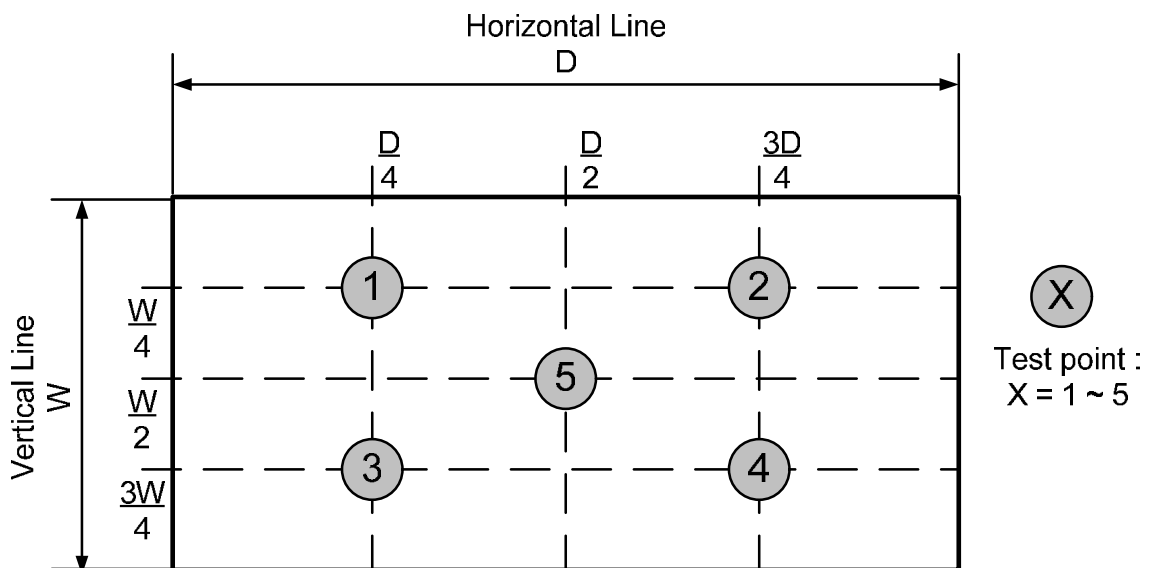

7. PRECAUTIONS

7.1 ASSEMBLY AND HANDLING PRECAUTIONS

- [1] Do not apply rough force such as bending or twisting to the module during assembly.
- [2] Do not apply pressure or impulse to the module to prevent the damage of LCD panel and Backlight.
- [3] Bezel of Set can not press or touch the panel surface. It will make light leakage or scrape.
- [4] It should be attached to the system firmly using all mounting holes.
- [5] It is recommended to assemble or to install a module into the user's system in clean working areas. The dust and oil may cause electrical short or worsen the polarizer, do not press or scratch the surface harder than a HB pencil lead.
- [6] Use finger-stalls with soft gloves in order to keep display clean during the incoming inspection and assembly process.
- [7] Protection film for polarizer on the module should be slowly peeled off just before use so that the electrostatic charge can be minimized.
- [8] Do not disassemble the module.
- [9] Always follow the correct power-on sequence when the LCD module is turned on. This can prevent the damage and latch-up of the CMOS LSI chips.
- [10] Do not plug in or pull out the I/F connector while the module is in operation, pins of I/F connector should not be touched directly with bare hands. Do not adjust the variable resistor located on the module.
- [11] Moisture can easily penetrate into LCD module and may cause the damage during operation.
- [12] When storing modules as spares for a long time, the following precaution is necessary.
 - [12.1] Do not leave the module in high temperature, and high humidity for a long time. It is highly recommended to store the module with temperature from 0 to 35°C at normal humidity (under 70%) without condensation.
 - [12.2] The module shall be stored in dark place. Do not store the TFT-LCD module in direct sunlight or fluorescent light.
- [13] When ambient temperature is lower than 10°C, the display quality might be reduced. For example, the response time will become slow, and the starting voltage of LED will be higher than that of room temperature.

7.2 SAFETY PRECAUTIONS

To optimize PID module's lifetime and functions, operating conditions should be followed as below

[1] Normal operating condition

[1.1] Temperature : $20\pm 15^{\circ}\text{C}$

[1.2] Humidity : $55\pm 20\%$

[1.3] Well-ventilated place is suggested to set up PID module and system.

[1.4] Display pattern : regular switched patterns or moving pictures.

[2] Operation usage to protect against image sticking due to long-term static display .

[2.1] Suitable operating time : under 24 hours a day.

(* The moving picture can be allowed for 24 hours a day)

[2.2] Liquid Crystal refresh time is required. Cycling display between 5 minutes' information (static) display and 10 seconds' moving image.

[2.3] Periodical display contents should be changed from static image to moving picture.

[2.3.1] Different background and image colors changed respectively, and changed colors periodically.

[2.3.2] Background and image with large different luminance displayed at the same time should be avoided.

[2.3.3] Periodical power-off the system for a while or screen saver is needed after long-term static display.

[2.3.4] Moving picture or black pattern is strongly recommended for screen saver.

[3] The startup voltage of a Backlight may cause an electrical shock while assembling with the converter. Do not disassemble the module or insert anything into the Backlight unit.

[4] Do not connect or disconnect the module in the "Power On" condition.

[5] Do not exceed the absolute maximum rating value. (supply voltage variation, input voltage variation, variation in part contents and environmental temperature...) Otherwise the module may be damaged.

[6] If the liquid crystal material leaks from the panel, it should be kept away from the eyes or mouth. In case of contact with hands, skin or clothes, it has to be washed away thoroughly with soap.

[7] Module should be turned clockwise (regular front view perspective) when used in portrait mode.

[8] Ultra-violet ray filter is necessary for outdoor operation.

[9] Only when PID module is operated under right operating conditions, lifetime in this spec can be guaranteed. After the module's end of life, it is not harmful in case of normal operation and storage.

7.3 SAFETY STANDARDS

The LCD module should be certified with safety regulations as follows:

Regulatory	Item	Standard
Information Technology equipment	UL	UL 60950-1,2nd Ed, 2014
	cUL	CSA C22.2 No.60950-1-07, 2nd Ed,2014-10
	CB	IEC60950-1:2005+ A1:2009+ A2:2013 / EN60950-1:2006+ A11:2009+ A1:2010+ A12:2011+ A2:2013
Audio/Video Apparatus	UL	UL 60065, 7th Edition, 2013
	cUL	CAN/CSA-C22.2 No. 60065-03, 1st Edition + A1:2006 + A2:2012
	CB	IEC 60065:2001 (Seventh Edition)+ A1:2005+A2:2010 / EN60065:2002+ A1:2006+ A11:2008+ A2:2010+ A12:2011

If the module displays the same pattern for a long period of time, the phenomenon of image sticking may be occurred.

8. DEFINITION OF LABELS

8.1 MODULE LABEL

The barcode nameplate is pasted on each module as illustration, and its definitions are as following explanation.



Model Name : S500DJ2-KS5

Revision : Rev. XX, for example: A0, A1... B1, B2... or C1, C2...etc.

Serial ID : XXXXXXYYMDLNNNN

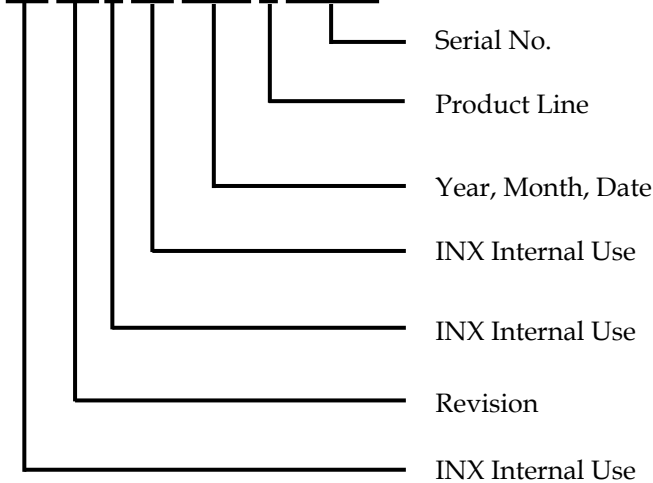

Serial ID includes the information as below :

Manufactured Date :

Year : 2001=1, 2002=2, 2003=3, 2004=4...2010=0, 2011=1, 2012=2...

Month: 1~9, A~C, for Jan. ~ Dec.

Day: 1~9, A~Y, for 1st to 31st, exclude I, O, and U.

Revision Code : Cover all the change

Serial No. : Manufacturing sequence of product

Product Line : 1→Line1, 2→Line 2, ...etc.

8.2 CARTON LABEL

The barcode nameplate is pasted on each box as illustration, and its definitions are as following explanation.

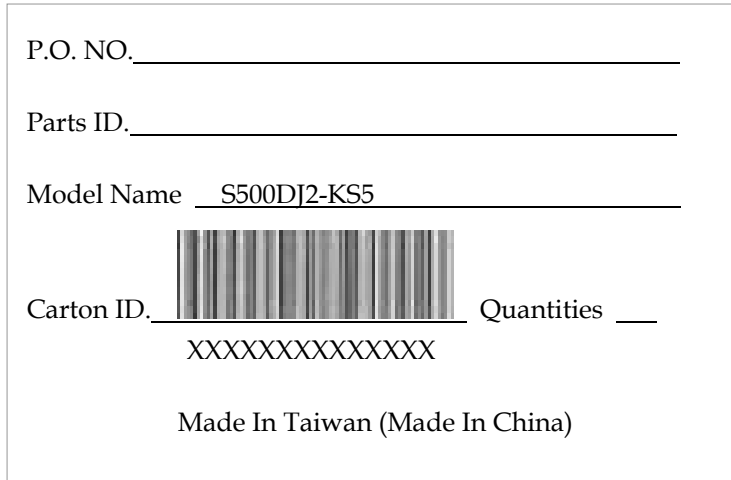

Model Name: S500DJ2- KS5

Carton ID: X X X X X X Y M D X X X X

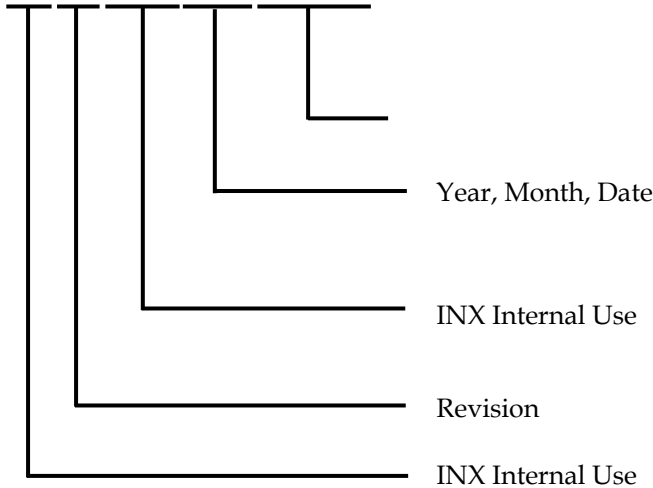

Serial ID includes the information as below :

Manufactured Date:

Year: 2010=0, 2011=1, 2012=2...etc.

Month: 1~9, A~C, for Jan. ~ Dec.

Day: 1~9, A~Y, for 1st to 31st, exclude I ,O, and U.

Revision Code: Cover all the change

9. PACKAGING

9.1 PACKAGING SPECIFICATIONS

- (1) 9 LCD TV MODULES / 1 BOX
- (2) BOX DIMENSIONS : 1230(L) X 515 (W) X 717 (H)
- (3) WEIGHT: APPROXIMATELY 113 KG (9 MODULES PER BOX)

9.2 PACKAGING METHOD

Packaging method is shown in following Figures 9-1 and 9-2

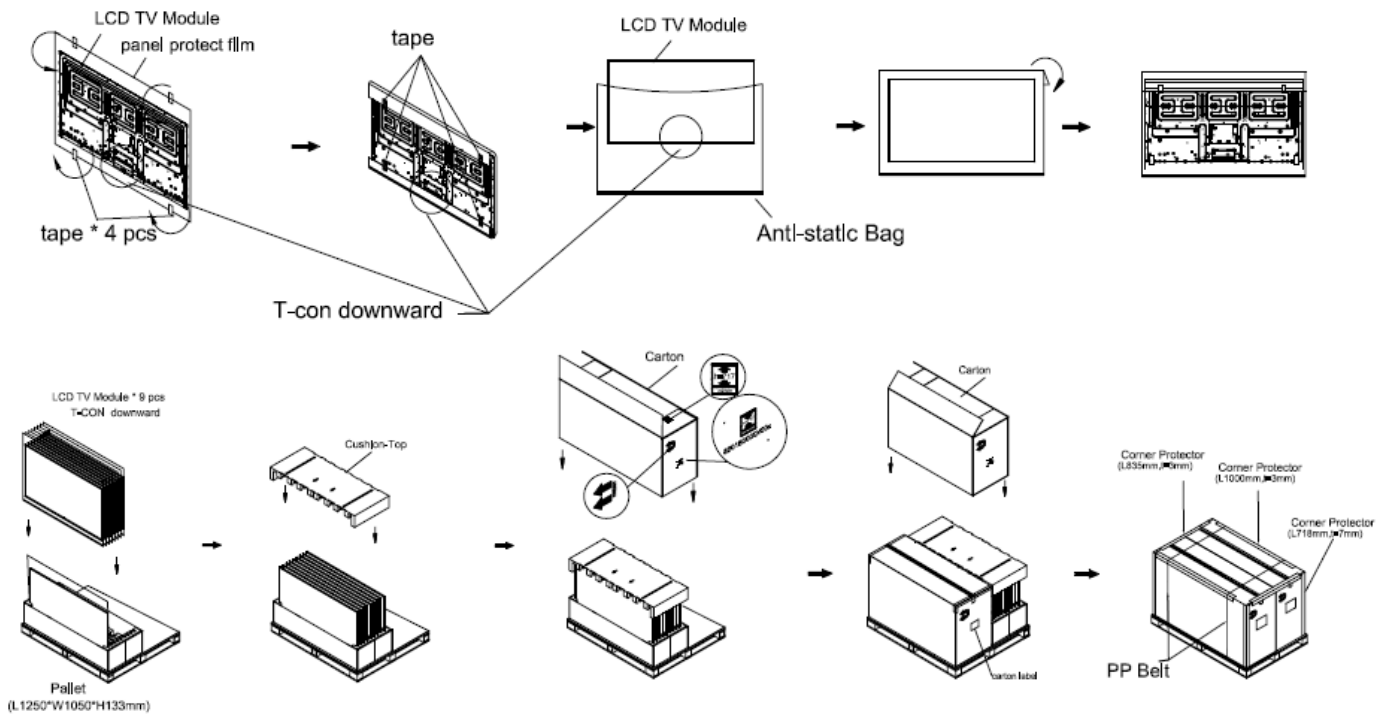

Figure 9-1 packaging method

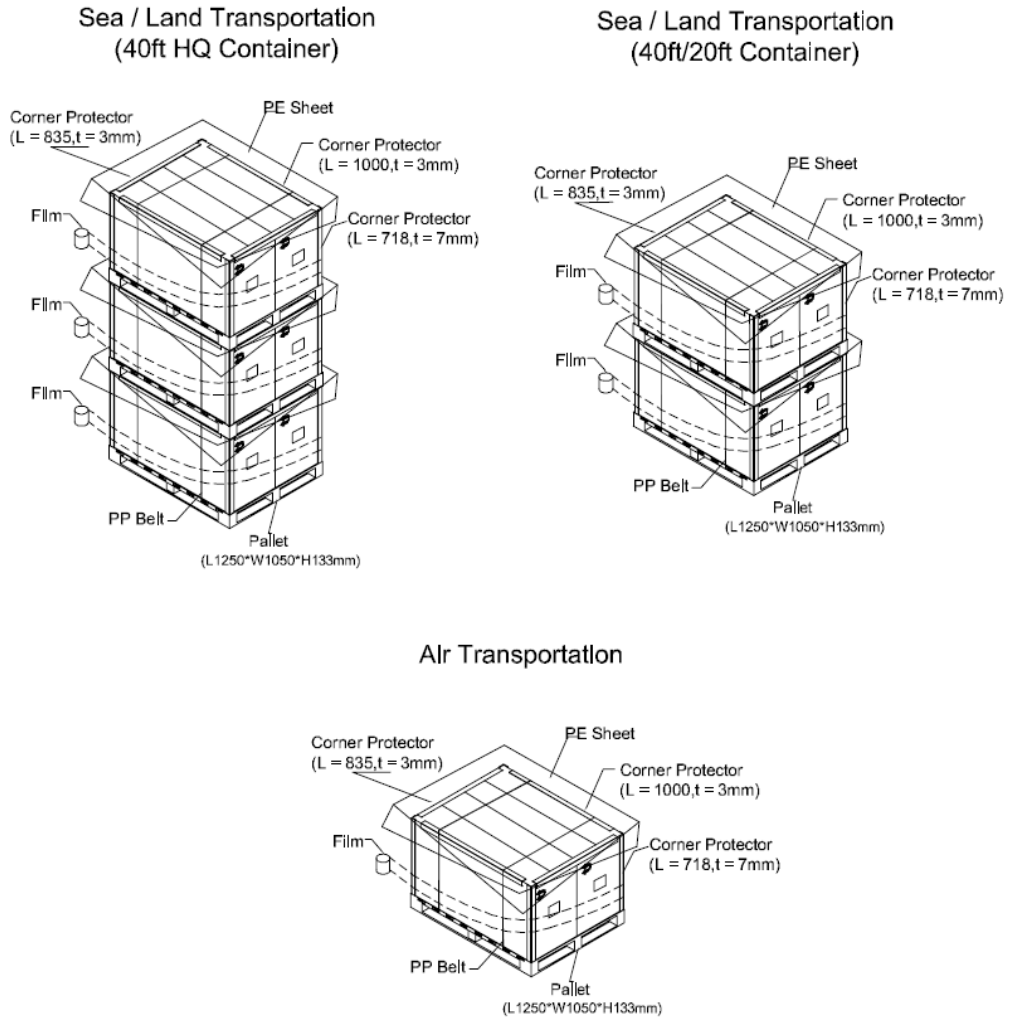

Figure. 9-2 packaging method

9.3 UN-PACKAGING METHOD

Un-packaging method is shown in following Figure.9-3.

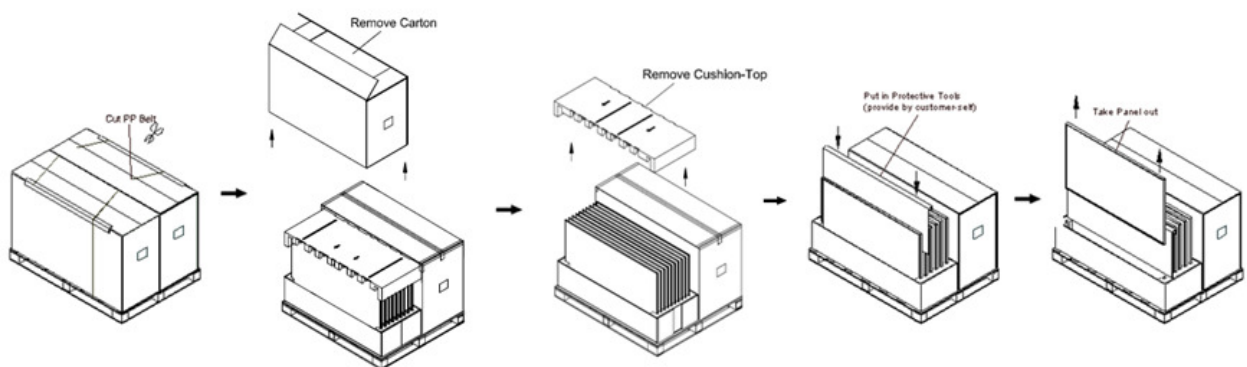
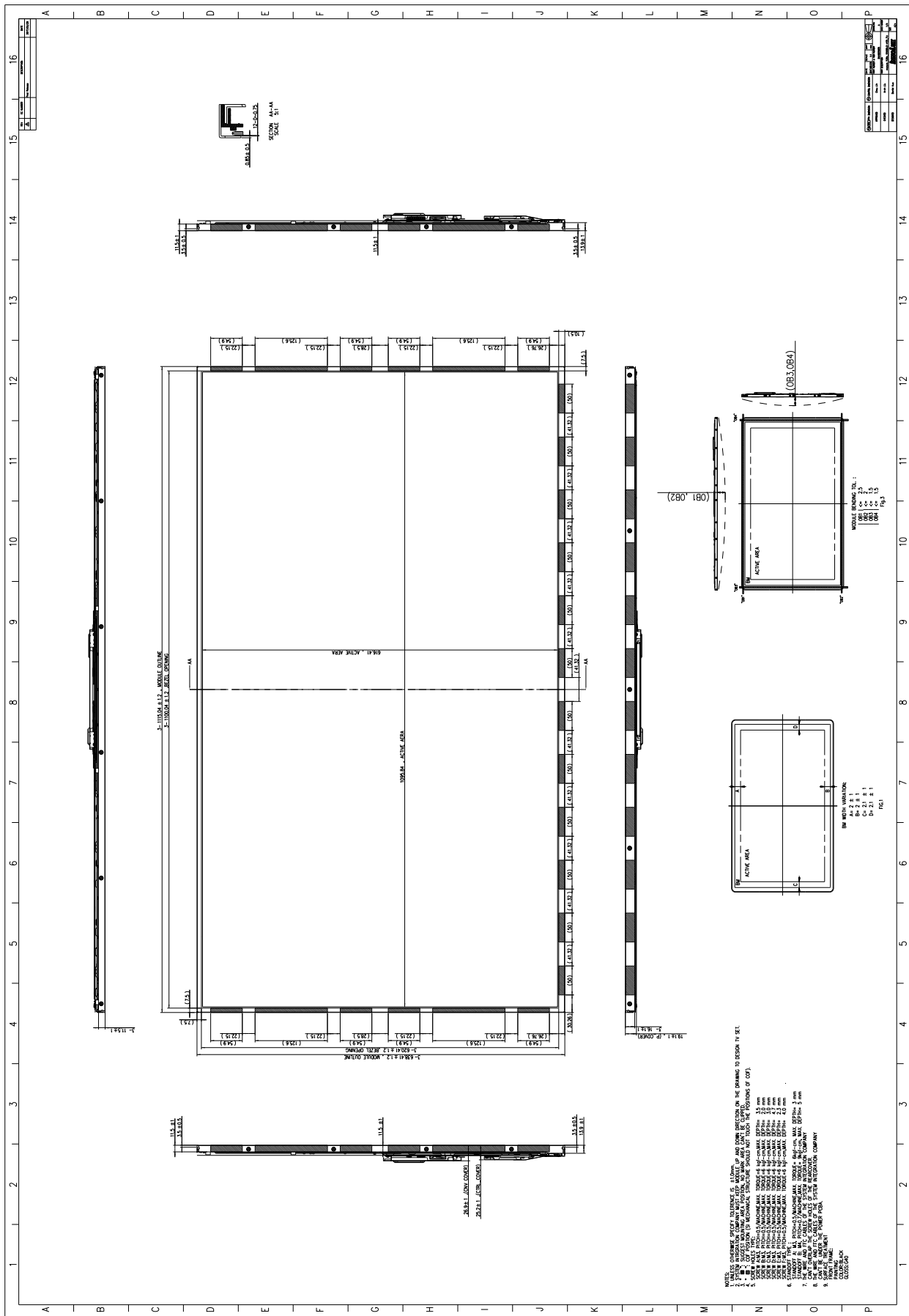
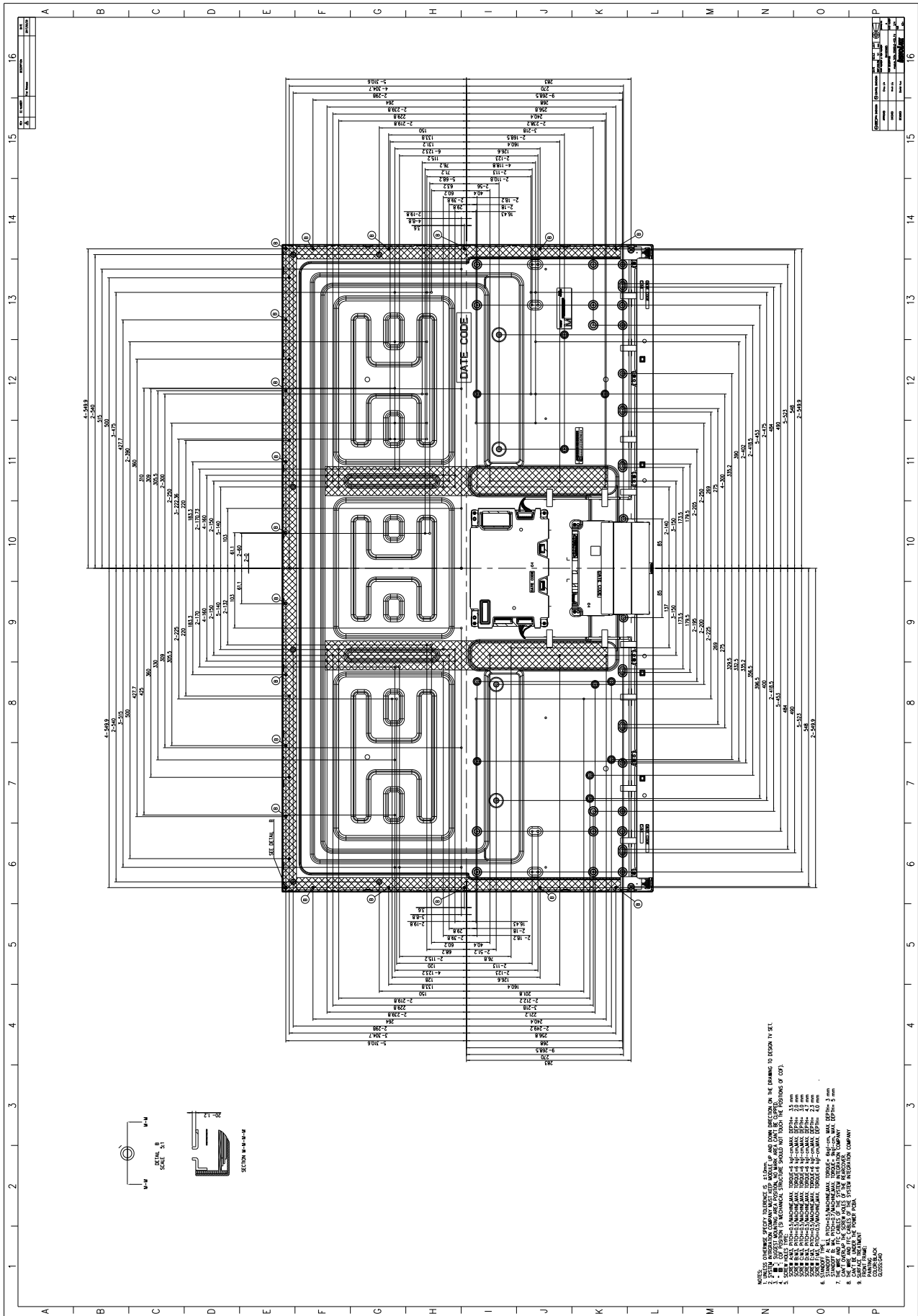

Figure. 9-3 un-packaging method

10. MECHANICAL CHARACTERISTIC



NOTES:
 1. DIMENSIONS OF DISPLAY PANELS ARE MEASURED UP AND DOWN BASED ON THE EXPANDED TO SECTION IN SET.
 2. DIMENSIONS OF DISPLAY PANELS ARE MEASURED FROM THE CENTER OF THE DISPLAY PANEL TO THE CENTER OF THE DISPLAY PANEL.
 3. DIMENSIONS OF DISPLAY PANELS ARE MEASURED FROM THE CENTER OF THE DISPLAY PANEL TO THE CENTER OF THE DISPLAY PANEL.
 4. DIMENSIONS OF DISPLAY PANELS ARE MEASURED FROM THE CENTER OF THE DISPLAY PANEL TO THE CENTER OF THE DISPLAY PANEL.
 5. DIMENSIONS OF DISPLAY PANELS ARE MEASURED FROM THE CENTER OF THE DISPLAY PANEL TO THE CENTER OF THE DISPLAY PANEL.
 6. DIMENSIONS OF DISPLAY PANELS ARE MEASURED FROM THE CENTER OF THE DISPLAY PANEL TO THE CENTER OF THE DISPLAY PANEL.
 7. DIMENSIONS OF DISPLAY PANELS ARE MEASURED FROM THE CENTER OF THE DISPLAY PANEL TO THE CENTER OF THE DISPLAY PANEL.
 8. DIMENSIONS OF DISPLAY PANELS ARE MEASURED FROM THE CENTER OF THE DISPLAY PANEL TO THE CENTER OF THE DISPLAY PANEL.
 9. DIMENSIONS OF DISPLAY PANELS ARE MEASURED FROM THE CENTER OF THE DISPLAY PANEL TO THE CENTER OF THE DISPLAY PANEL.
 10. DIMENSIONS OF DISPLAY PANELS ARE MEASURED FROM THE CENTER OF THE DISPLAY PANEL TO THE CENTER OF THE DISPLAY PANEL.
 11. DIMENSIONS OF DISPLAY PANELS ARE MEASURED FROM THE CENTER OF THE DISPLAY PANEL TO THE CENTER OF THE DISPLAY PANEL.
 12. DIMENSIONS OF DISPLAY PANELS ARE MEASURED FROM THE CENTER OF THE DISPLAY PANEL TO THE CENTER OF THE DISPLAY PANEL.
 13. DIMENSIONS OF DISPLAY PANELS ARE MEASURED FROM THE CENTER OF THE DISPLAY PANEL TO THE CENTER OF THE DISPLAY PANEL.
 14. DIMENSIONS OF DISPLAY PANELS ARE MEASURED FROM THE CENTER OF THE DISPLAY PANEL TO THE CENTER OF THE DISPLAY PANEL.
 15. DIMENSIONS OF DISPLAY PANELS ARE MEASURED FROM THE CENTER OF THE DISPLAY PANEL TO THE CENTER OF THE DISPLAY PANEL.
 16. DIMENSIONS OF DISPLAY PANELS ARE MEASURED FROM THE CENTER OF THE DISPLAY PANEL TO THE CENTER OF THE DISPLAY PANEL.



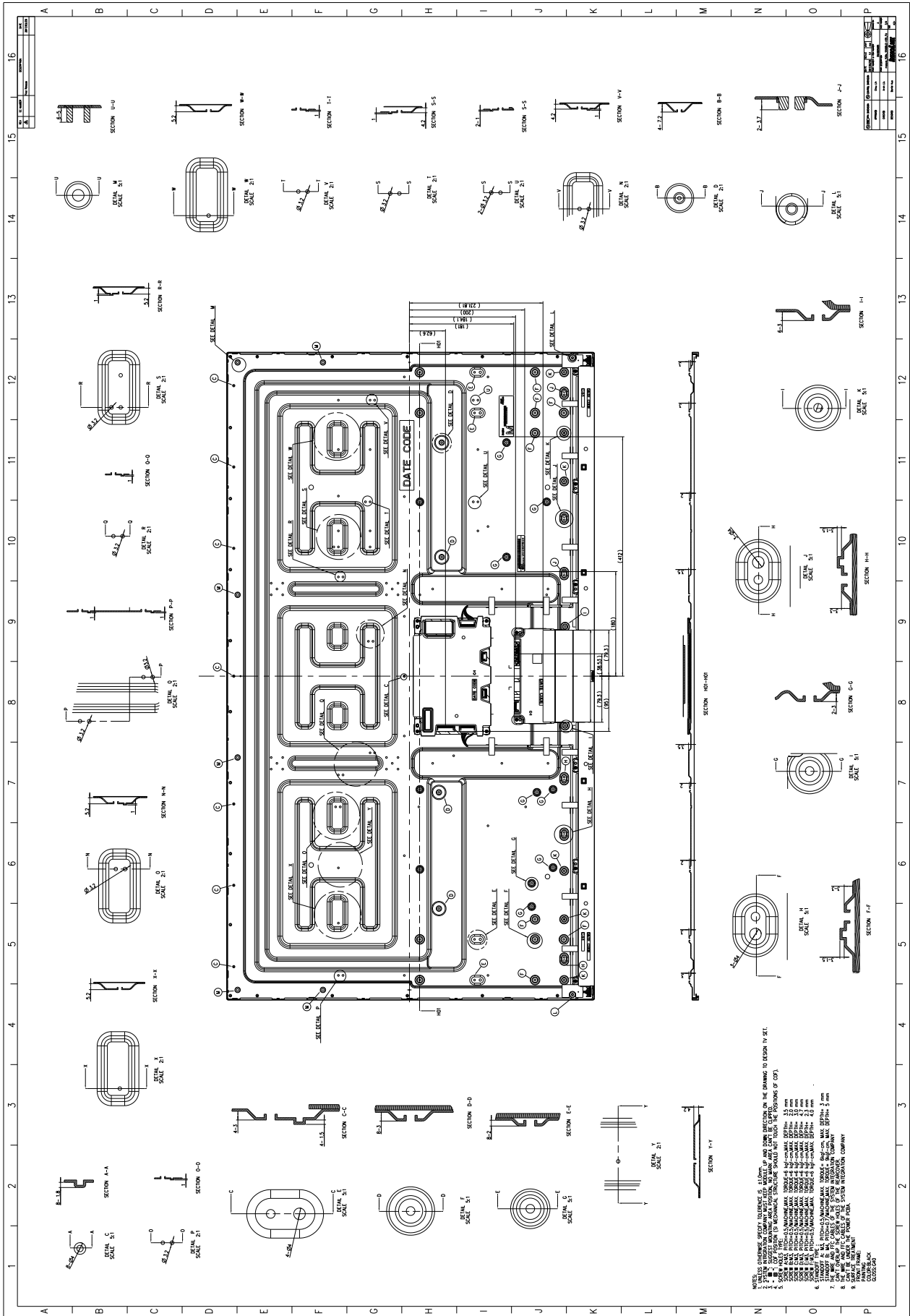

NOTES:
 1. DIMENSIONS UNLESS OTHERWISE SPECIFIED ARE IN MILLIMETERS.
 2. SURFACE FINISH SHALL BE AS SPECIFIED IN THE DRAWING.
 3. DIMENSIONS SHALL BE TO UNLESS OTHERWISE SPECIFIED.
 4. DIMENSIONS SHALL BE TO UNLESS OTHERWISE SPECIFIED.
 5. DIMENSIONS SHALL BE TO UNLESS OTHERWISE SPECIFIED.
 6. DIMENSIONS SHALL BE TO UNLESS OTHERWISE SPECIFIED.
 7. DIMENSIONS SHALL BE TO UNLESS OTHERWISE SPECIFIED.
 8. DIMENSIONS SHALL BE TO UNLESS OTHERWISE SPECIFIED.
 9. DIMENSIONS SHALL BE TO UNLESS OTHERWISE SPECIFIED.
 10. DIMENSIONS SHALL BE TO UNLESS OTHERWISE SPECIFIED.
 11. DIMENSIONS SHALL BE TO UNLESS OTHERWISE SPECIFIED.
 12. DIMENSIONS SHALL BE TO UNLESS OTHERWISE SPECIFIED.
 13. DIMENSIONS SHALL BE TO UNLESS OTHERWISE SPECIFIED.
 14. DIMENSIONS SHALL BE TO UNLESS OTHERWISE SPECIFIED.
 15. DIMENSIONS SHALL BE TO UNLESS OTHERWISE SPECIFIED.
 16. DIMENSIONS SHALL BE TO UNLESS OTHERWISE SPECIFIED.
 17. DIMENSIONS SHALL BE TO UNLESS OTHERWISE SPECIFIED.
 18. DIMENSIONS SHALL BE TO UNLESS OTHERWISE SPECIFIED.
 19. DIMENSIONS SHALL BE TO UNLESS OTHERWISE SPECIFIED.
 20. DIMENSIONS SHALL BE TO UNLESS OTHERWISE SPECIFIED.



ALL TECHNOLOGIES. ALL COMPETENCIES. ONE SPECIALIST.



DATA MODUL AG
Landsberger Straße 322 DE-
80687 Munich
Phone: +49-89-56017-0

DATA MODUL WEIKERSHEIM GMBH
Lindenstraße 8
DE-97990 Weikersheim Phone:
+49-7934-101-0



More information and worldwide locations can be found at

www.data-modul.com