



**MODEL NO** : TM101JDHG30  
**MODEL VERSION:** 00  
**SPEC VERSION :** V2.0  
**ISSUED DATE:** 2016-05-12

Preliminary Specification  
 Final Product Specification

Customer : \_\_\_\_\_

Approved by	Notes

TIANMA Confirmed :

Prepared by	Checked by	Approved by
Gang.li	Longping.Deng	<b>Feng.Qin</b>

This technical specification is subjected to change without notice



## Table of Contents

Table of Contents.....	2
Record of Revision .....	3
1 General Specifications .....	4
2 Input/Output Terminals .....	5
3 Absolute Maximum Ratings .....	6
4 Electrical Characteristics.....	7
5 Timing Chart .....	10
6 Optical Characteristics .....	13
7 Environmental / Reliability Test .....	17
8 Mechanical Drawing.....	18
9 Packing Drawing.....	19
10 Precautions For Use of LCD Modules .....	22



## Record of Revision

<b>Rev</b>	<b>Issued Date</b>	<b>Description</b>	<b>Editor</b>
1.0	2015-10-10	Preliminary Specification Released.	Gang.li
1.1	2015-11-04	Update more details.	Gang.li
1.2	2016-01-05	Update mechanical drawing.	Gang.li
1.3	2016-03-07	Update backlight power consumption on page8; Update packaging method on page19.	Gang.li
2.0	2016-05-12	Update optical characteristics. Final specification released.	Gang.li



## 1 General Specifications

	Feature	Spec
<b>Display Spec.</b>	Size	10.1 inch
	Resolution	1280(RGB) x 800
	Technology Type	SFT
	Pixel Configuration	R.G.B. Vertical Stripe
	Pixel Pitch (mm)	0.1695x0.1695
	Display Mode	Transmissive, Normally Black
	Surface Treatment(Up Polarizer)	HC
	Viewing Direction	All direction
<b>Mechanical Characteristics</b>	LCM (W x H x D) (mm)	231.22x150.60x4.30
	Active Area(mm)	216.96x135.60
	With /Without TSP	Without TSP
	Matching Connection Type	IPEX 20453-040T-1 or compatible
	Weight (g)	280
<b>Electrical Characteristics</b>	Interface	1port LVDS, 6/8bit selectable
	Color Depth	262K/16.7M
	Driver IC	ST5084*1,ST5821*3

Note 1: Viewing direction for best image quality is different from TFT definition, there is a 180 degree shift.

Note 2 : Requirements on Environmental Protection: Q/S0002

Note 3 : LCM weight tolerance : +/- 5%



## 2 Input/Output Terminals

### 2.1 TFT LCD Panel

Connector type: JAE HD1S040HA1 or compatible  
Mating Connector: IPEX 20453-040T-1 or compatible

No	Symbol	I/O	Description	Comment
1	NC	-	No Connection	
2	VDD	P	Power Supply +3.3V	
3	VDD	P	Power Supply +3.3V	
4	VDD	P	Power Supply +3.3V	
5	NC	-	No Connection	
6	NC	-	No Connection	
7	NC	-	No Connection	
8	Rxin0-	I	-LVDS differential data input(R0~R5,G0)	
9	Rxin0+	I	+LVDS differential data input(R0~R5,G0)	
10	GND	P	Power ground	
11	Rxin1-	I	-LVDS differential data input(G1~G5,B0~B1)	
12	Rxin1+	I	+LVDS differential data input(G1~G5,B0~B1)	
13	GND	P	Power ground	
14	Rxin2-	I	-LVDS differential data input(B2~B5,HS,VS,DE)	
15	Rxin2+	I	+LVDS differential data input(B2~B5,HS,VS,DE)	
16	GND	P	Power ground	
17	RxCLK-	I	-LVDS differential data input	
18	RxCLK+	I	+LVDS differential data input	
19	GND	P	Power ground	
20	Rxin3-	I	-LVDS differential data input(R6~R7,G6~G7,B6~B7)	Connect to GND in 6 bit mode
21	Rxin3+	I	+LVDS differential data input(R6~R7,G6~G7,B6~B7)	
22	GND	P	Power ground	
23	NC	-	No Connection	
24	NC	-	No Connection	
25	GND	P	Power ground	
26	NC	-	No Connection	
27	SEL6/8	-	SEL6/8="H", 6bit; SEL6/8="L", 8bit	
28	GND	P	Power ground	
29	NC	-	No Connection	
30	NC	-	No Connection	
31	VLED_GND	P	VLED Ground	
32	VLED_GND	P	VLED Ground	
33	VLED_GND	P	VLED Ground	
34	NC	-	No Connection	
35	VLED_PWM	P	Backlight dimming control	
36	VLED_EN	P	Backlight on/off control	
37	NC	-	No Connection	
38	VLED	P	Backlight power supply	
39	VLED	P	Backlight power supply	
40	VLED	P	Backlight power supply	

Note: I/O definition:

I----Input      P----Power/Ground

The information contained herein is the exclusive property of SHANGHAI TIANMA MICRO-ELECTRONICS Corporation, and shall not be distributed, reproduced, or disclosed in whole or in part without prior written permission of SHANGHAI TIANMA MICRO-ELECTRONICS Corporation.



### 3 Absolute Maximum Ratings

#### 3.1 Driving TFT LCD Panel

GND=0V

Item	Symbol	MIN	MAX	Unit	Remark
Voltage Input	V <sub>in</sub>	-0.50	5.00	V	Note1
Operating Temperature	T <sub>op</sub>	-20.0	70.0	°C	
Storage Temperature	T <sub>st</sub>	-30.0	80.0	°C	
Relative Humidity (Note2)	RH	--	≤95	%	Ta≤40°C
		--	≤85	%	40°C < Ta ≤ 50°C
		--	≤55	%	50°C < Ta ≤ 60°C
		--	≤36	%	60°C < Ta ≤ 70°C
		--	≤24	%	70°C < Ta ≤ 80°C
Absolute Humidity	AH	--	≤70	g/m <sup>3</sup>	Ta > 70°C

**Table 3.1 absolute maximum rating**

Note1: Input voltage include Rxin0-/+, Rxin1-/+, Rxin2-/+, Rxin3-/+, RxCLK-/+, SEL6/8,VDD.

Note2: Ta means the ambient temperature.

It is necessary to limit the relative humidity to the specified temperature range.

Condensation on the module is not allowed.



## 4 Electrical Characteristics

### 4.1 Driving TFT LCD Panel

VCC=3.3V,GND=0V, Ta=25°C

Item	Symbol	MIN	TYP	MAX	Unit	Remark
Power supply Voltage	VDD	3.00	3.30	3.60	V	
Power supply ripple	Vp-p	-	-	100	mV	
Power supply current	IDD	-	280	-	mA	
Power consumption	P	-	924	-	mW	Note1
Differential input voltage	Vid	200	-	600	mV	
Differential input common voltage	Vcm	-	1.2	-	V	
Differential input threshold voltage	Low level	VTL	-100	-	-	mV
	High level	VTH	-	-	100	mV
Inrush current	Irush	-	-	1.5	A	

Table 4.1 LCD module electrical characteristics

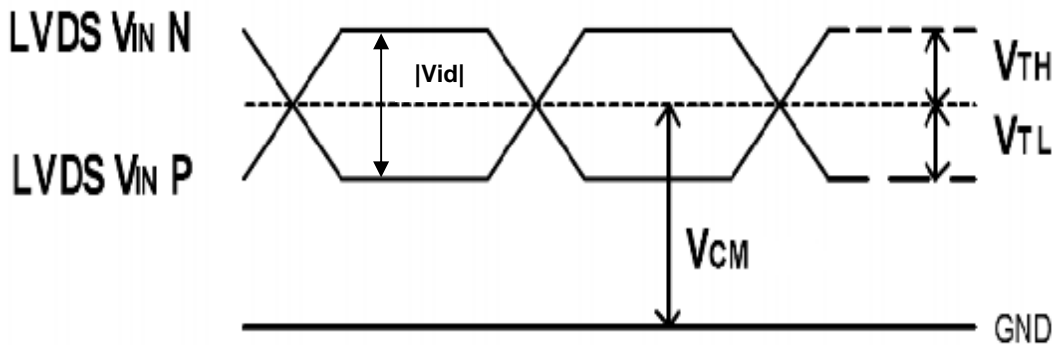

Figure 4.1 LVDS DC characteristics

Note1: To test the current dissipation, using the “color bar” testing pattern shown as below:

1. White
2. Yellow
3. Cyan
4. Green
5. Magenta
6. Red
7. Blue
8. Black

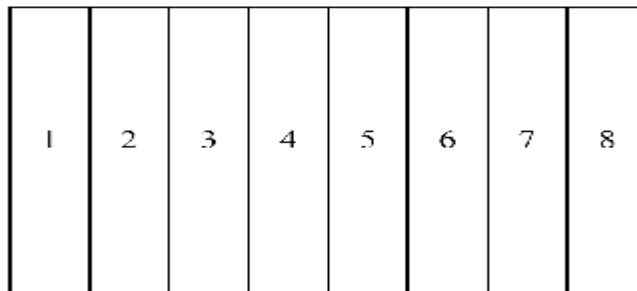

Figure 4.1.2 Current dissipation testing pattern



## 4.2 Driving Backlight

Ta=25°C

Item	Symbol	Min	Typ	Max	Unit	Remark	
Backlight power supply voltage	VLED	5.5	12	12.5	V		
Backlight power supply current	I_LED	-	322	-	mA		
Backlight power consumption	P_LED	-	3864	-	mW		
Input voltage for VLED_PWM signal	High level	-	2.0	-	5.0	V	
	Low level	-	0	-	0.4	V	
Input voltage for VLED_EN	High level	-	2.0	-	5.0	V	
	Low level	-	0	-	0.4	V	
VLED_PWM frequency	Fpwm	200	-	20k	HZ		
VLED_PWM duty	D	5		100	%	Note1	
Operating Life Time	--	--	50000	--	hrs	Note2	

Note 1: According to LED driver IC characteristics, the minimum value of VLED\_PWM duty may vary with VLED\_PWM frequency, higher the frequency, bigger the duty.

Note 2: Optical performance should be evaluated at Ta=25°C only.

If LED is driven by high current, high ambient temperature & humidity condition. The life time of LED will be reduced.

Operating life means brightness goes down to 50% of initial brightness.

Typical operating life time is estimated data.





4.3 Block Diagram

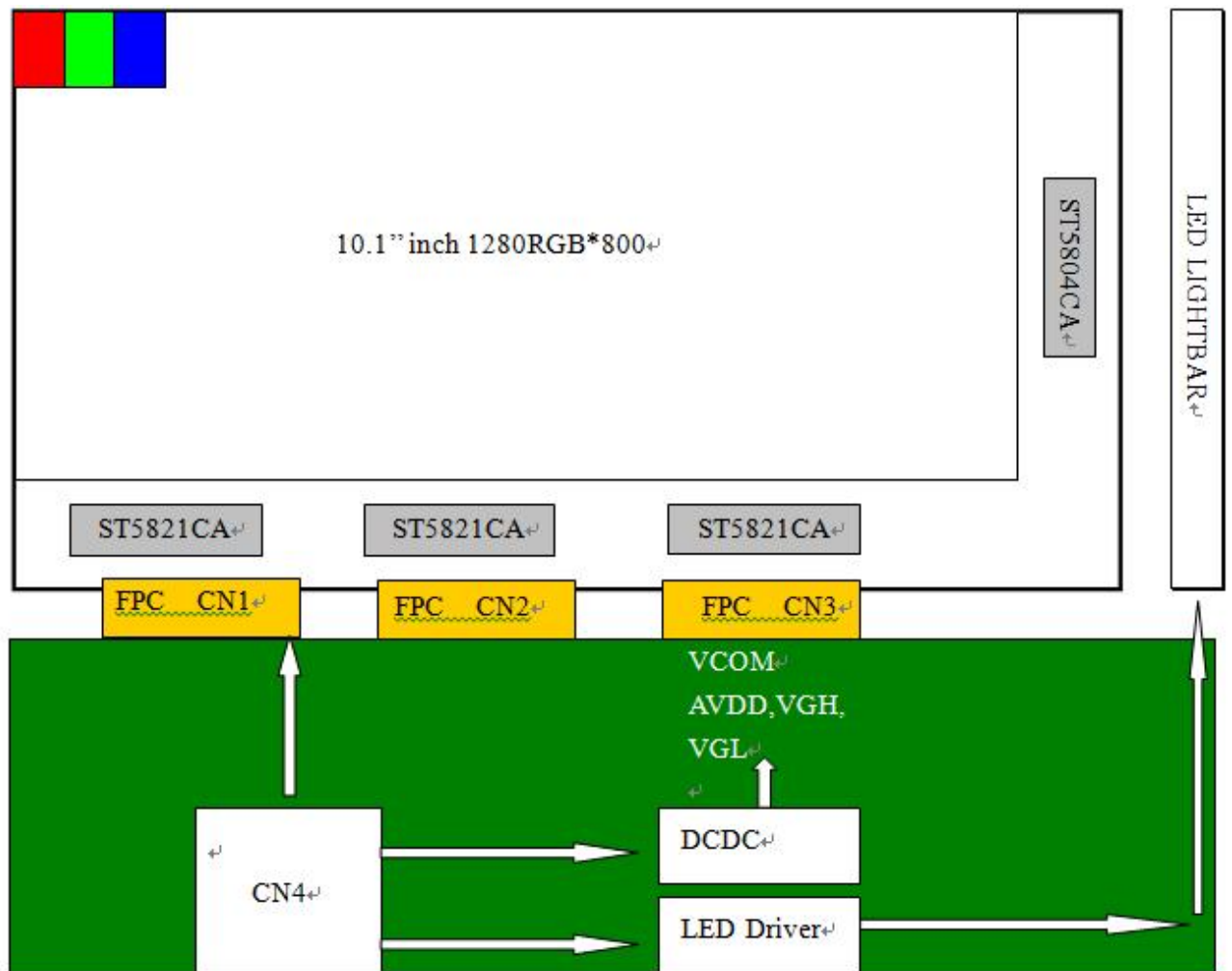



## 5 Timing Chart

### 5.1 LVDS signal timing characteristics

VCC=3.3V, GND=0V, Ta=25°C

Parameter	Symbol	Min	Typ	Max	Unit	Remark
CLK frequency	1/t <sub>clk</sub>	62.6	68.2	78.1	MHz	
Horizontal blanking time	t <sub>HBT</sub>	20	69	164	t <sub>clk</sub>	t <sub>hbp</sub> + t <sub>HFP</sub>
Horizontal back porch	t <sub>HBP</sub>	-	5	164- t <sub>HFP</sub>	t <sub>clk</sub>	
Horizontal display area	t <sub>HD</sub>	-	1280	-	t <sub>clk</sub>	
Horizontal front porch	t <sub>HFP</sub>	15	64	159	t <sub>clk</sub>	
Horizontal period	t <sub>H</sub>	1300	1349	1444	t <sub>clk</sub>	
Horizontal pulse width	t <sub>HPW</sub>	-	1	256	t <sub>clk</sub>	
Vertical blanking time	t <sub>VBT</sub>	5	42	101	t <sub>H</sub>	t <sub>vbp</sub> + t <sub>vfp</sub>
Vertical back porch	t <sub>VBP</sub>	-	2	101- t <sub>vfp</sub>	t <sub>H</sub>	
Vertical display area	t <sub>VD</sub>	-	800	-	t <sub>H</sub>	
Vertical front porch	t <sub>vfp</sub>	3	40	99	t <sub>H</sub>	
Vertical period	t <sub>V</sub>	803	842	901	t <sub>H</sub>	
Vertical pulse width	t <sub>VPW</sub>	-	1	128	t <sub>H</sub>	
Frame Rate	F	-	60	-	HZ	

Table 5.1 timing parameter

### 5.2 Input Clock and Data timing Diagram:

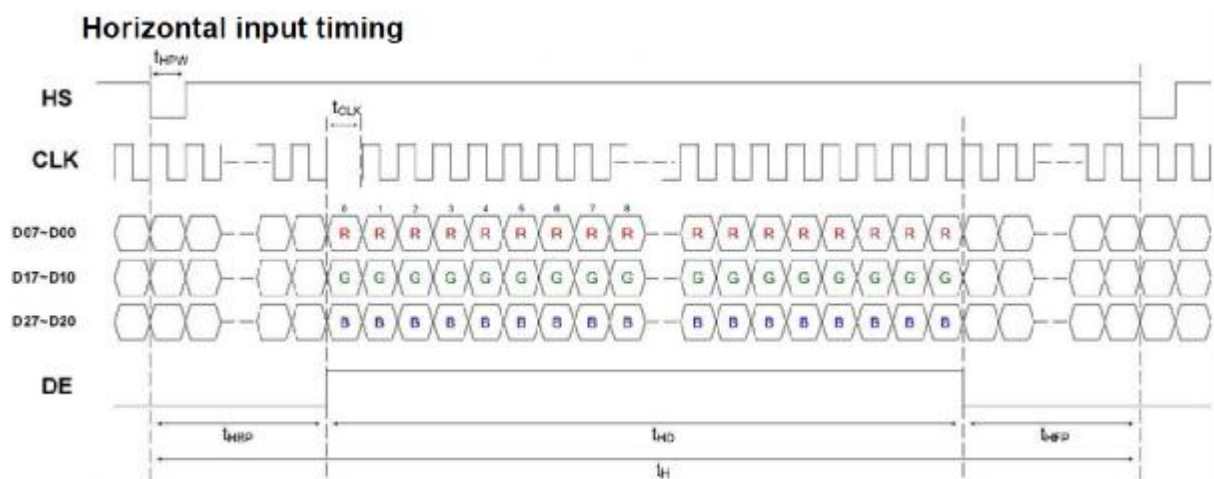

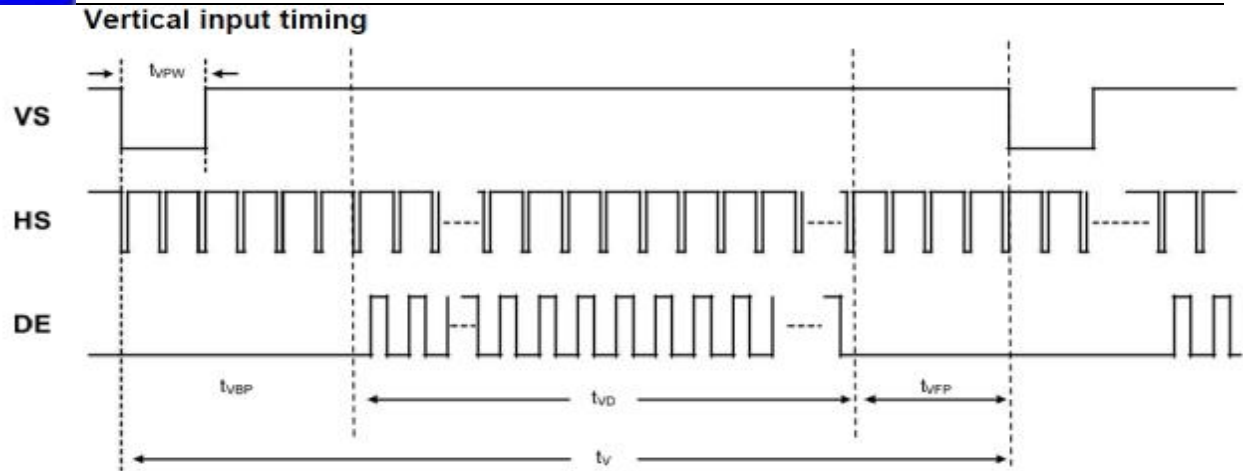
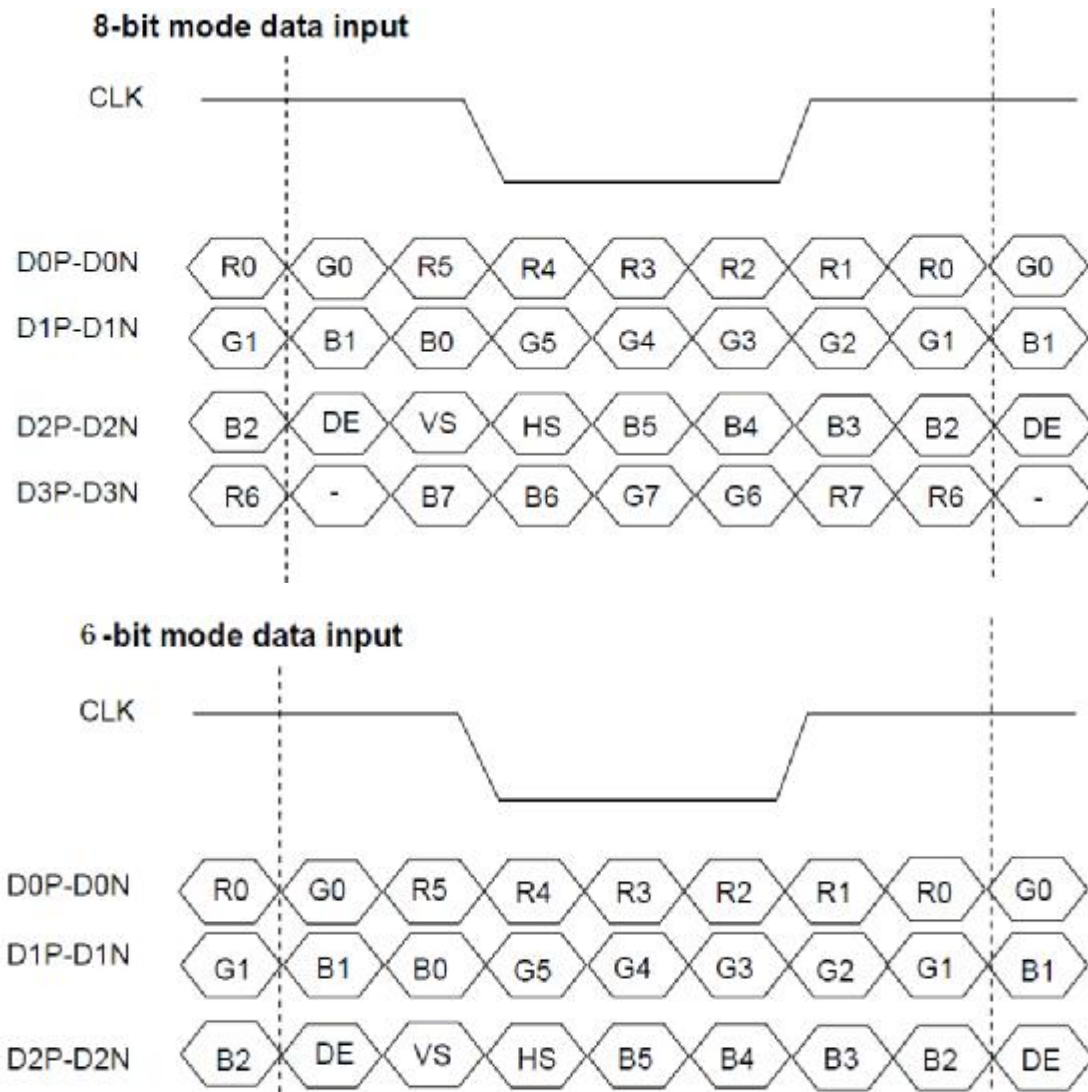

Figure 5.2 Input signal data timing

### 5.3 LVDS data input format





5.4 Power On/Off Sequence

Item	Symbol	Min	Typ	Max	Unit	Remark
VDD on to VDD stable	Tp1	0.5	-	10	ms	
VDD stable to signal on	Tp2	0	-	50	ms	
Signal on to VLED_EN on	Tp3	200	-	-	ms	
PWM on to VLED_EN on	Tp4	0	-	200	ms	
VLED to PWM on	Tp5	10	-	-	ms	
VLED on to VLED stable	Tp6	0.5	-	10	ms	
VDD off time	Tp7	0	-	10	ms	
VDD off to next VDD on	Tp8	500	-	-	ms	
Signal off before VDD off	Tp9	0	-	50	ms	
VLED_EN off before signal off	Tp10	200	-	-	ms	
VLED_EN off before PWM off	Tp11	0	-	200	ms	
PWM off before VLED off	Tp12	10	-	-	ms	

Table 5.1 Power on/off sequence

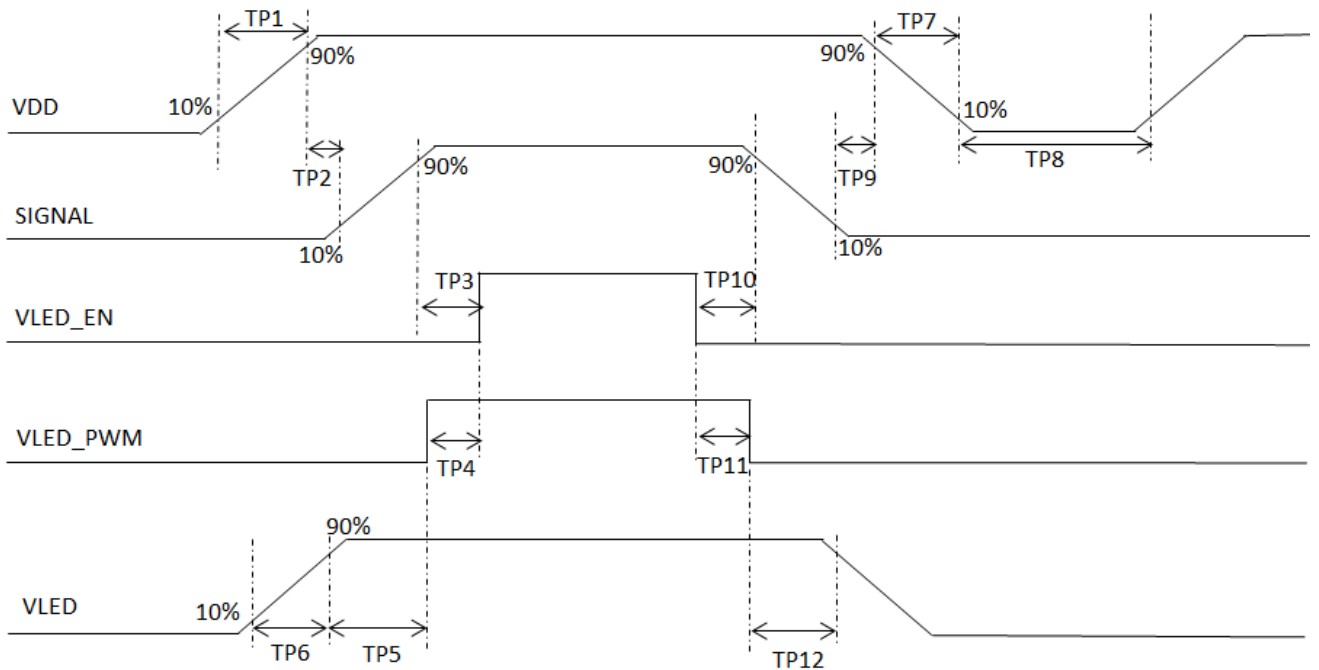

Figure 5.2 Interface power on/off sequence



## 6 Optical Characteristics

### 6.1 Optical Specification

Ta=25 °C

Item	Symbol	Condition	Min	Typ	Max	Unit	Remark	
View Angles	$\theta T$	$CR \cong 10$	75	85	-	Degree	Note 2	
	$\theta B$		75	85	-			
	$\theta L$		75	85	-			
	$\theta R$		75	85	-			
Contrast Ratio	CR	$\theta=0^\circ$	600	800	-	-	Note1 Note3	
Response Time	$T_{ON}$	25°C	-	10	15	ms	Note1	
	$T_{OFF}$		-	15	25		Note4	
Chromaticity	White	Backlight is on	x	0.252	0.302	0.352	-	Note5 Note1
			y	0.277	0.327	0.377		
	Red		x	0.528	0.578	0.628		
			y	0.272	0.322	0.372		
	Green		x	0.296	0.346	0.396		
			y	0.528	0.578	0.628		
	Blue		x	0.104	0.154	0.204		
			y	0.042	0.092	0.142		
Uniformity	U	-	75	80	-	%	Note1 Note6	
NTSC	-	-	-	50	-	%	Note 5	
Luminance	L		400	500	-	cd/m <sup>2</sup>	Note1 Note7	

Test Conditions:

1. The ambient temperature is 25±2°C.humidity is 65±7%
2. The test systems refer to Note 1 and Note 2.



Note 1: Definition of optical measurement system.

The optical characteristics should be measured in dark room. After 5 minutes operation, the optical properties are measured at the center point of the LCD screen. All input terminals LCD panel must be ground when measuring the center area of the panel.

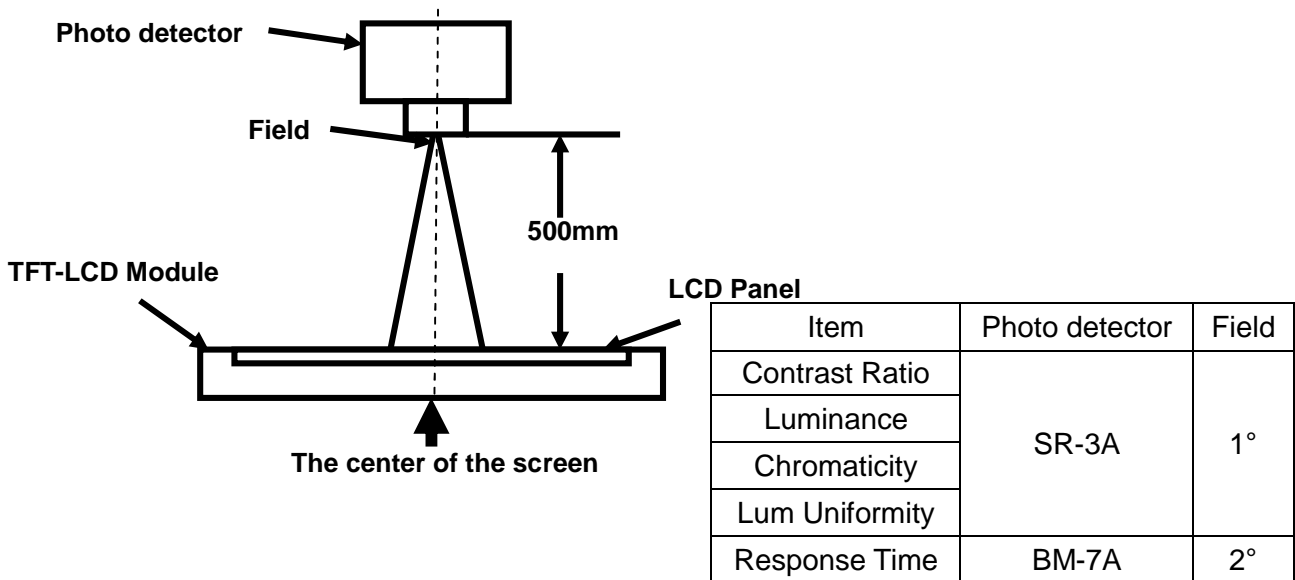

Note 2: Definition of viewing angle range and measurement system.

viewing angle is measured at the center point of the LCD by CONOSCOPE(ergo-80).

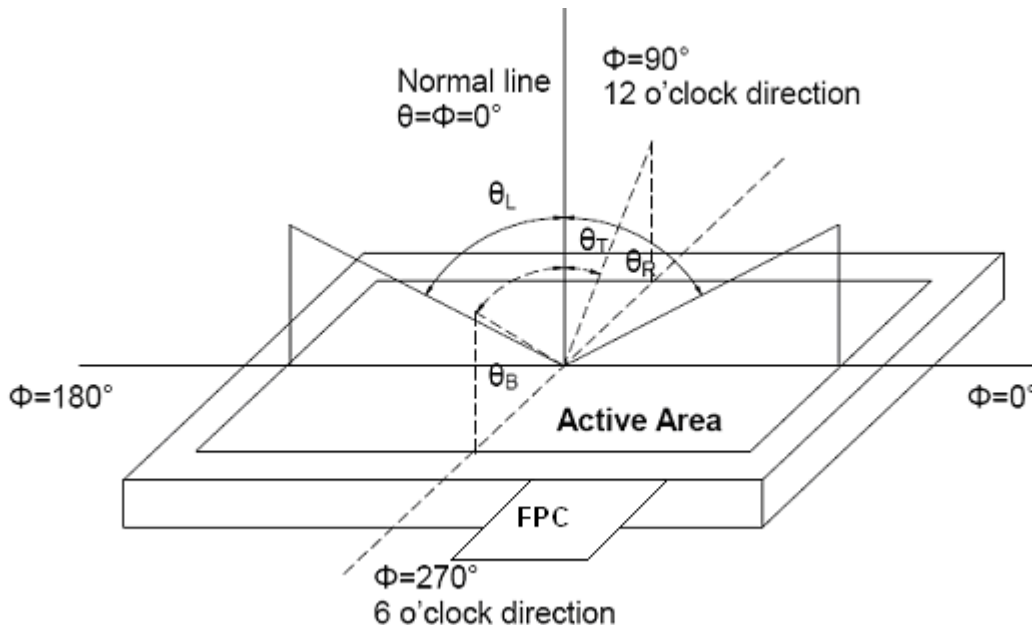

Fig. 1 Definition of viewing angle



Note 3: Definition of contrast ratio

$$\text{Contrast ratio (CR)} = \frac{\text{Luminance measured when LCD is on the "White" state}}{\text{Luminance measured when LCD is on the "Black" state}}$$

"White state": The state is that the LCD should be driven by  $V_{\text{white}}$ .

"Black state": The state is that the LCD should be driven by  $V_{\text{black}}$ .

$V_{\text{white}}$ : To be determined     $V_{\text{black}}$ : To be determined.

Note 4: Definition of Response time

The response time is defined as the LCD optical switching time interval between "White" state and "Black" state. Rise time ( $T_{\text{ON}}$ ) is the time between photo detector output intensity changed from 90% to 10%. And fall time ( $T_{\text{OFF}}$ ) is the time between photo detector output intensity changed from 10% to 90%.

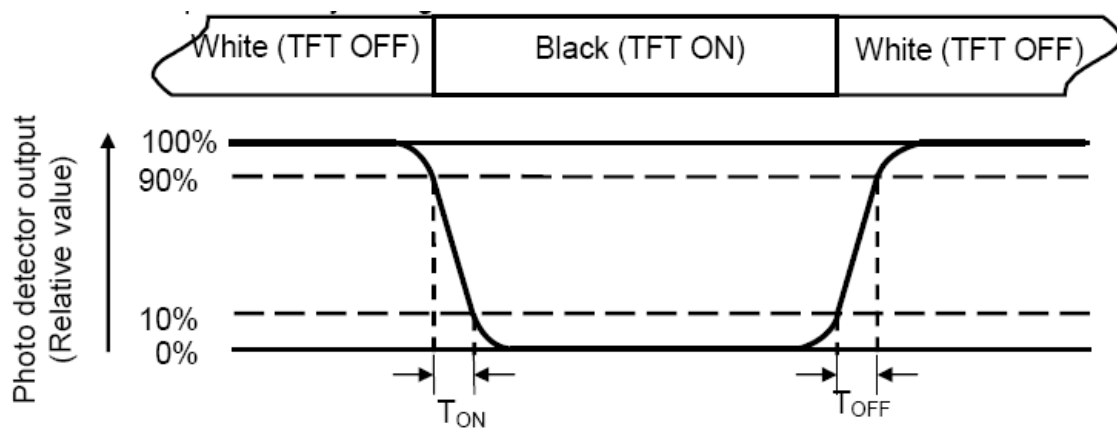

Note 5: Definition of color chromaticity (CIE1931)

Color coordinates measured at center point of LCD.



Note 6: Definition of Luminance Uniformity

Active area is divided into 9 measuring areas (Refer Fig. 2). Every measuring point is placed at the center of each measuring area.

$$\text{Luminance Uniformity}(U) = L_{\min} / L_{\max}$$

L-----Active area length W----- Active area width

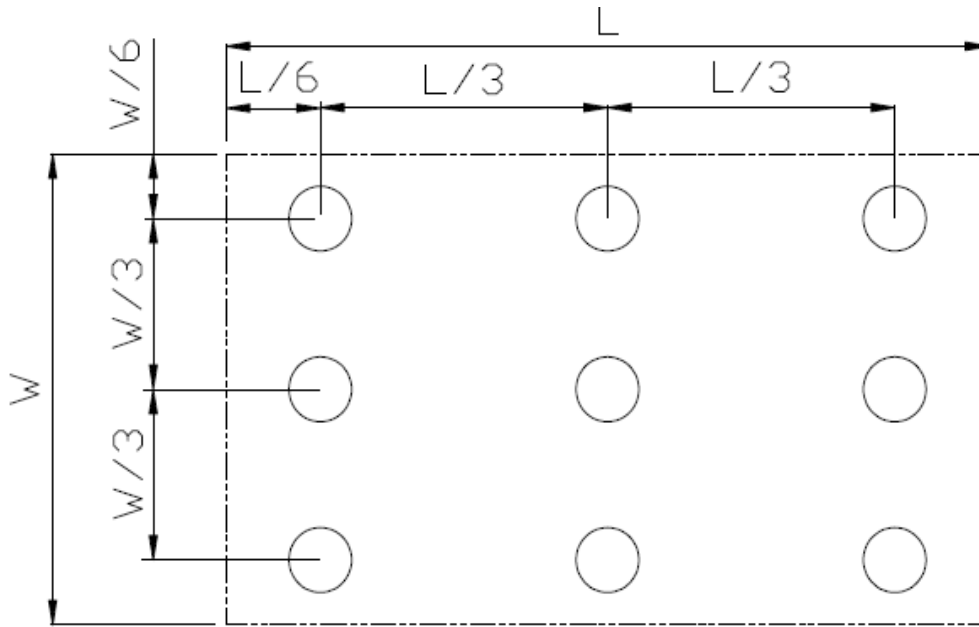

Fig. 2 Definition of uniformity

Lmax: The measured maximum luminance of all measurement position.

Lmin: The measured minimum luminance of all measurement position.

Note 7: Definition of Luminance :

Measure the luminance of white state at center point.





## 7 Environmental / Reliability Test

No	Test Item	Condition	Remark
1	High Temperature Operation	Ts=+70°C, 240hrs	(Note1) IEC60068-2-1:2007,GB2423.2-2008
2	Low Temperature Operation	Ta=-20°C, 240hrs	IEC60068-2-1:2007 GB2423.1-2008
3	High Temperature Storage (non-operation)	Ta=+80°C, 240hrs	IEC60068-2-1:2007 GB2423.2-2008
4	Low Temperature Storage (non-operation)	Ta=-30°C, 240hrs	IEC60068-2-1:2007 GB2423.1-2008
5	High Temperature & High Humidity Operation	Ta = +60°C, 90% RH max,240 hours	(Note2) IEC60068-2-78 :2001 GB/T2423.3—2006
6	Thermal Shock (non-operation)	-30°C 30 min~+80°C 30 min, Change time:5min,100cycles	Start with cold temperature, End with high temperature, IEC60068-2-14:1984,GB2423.22-2002
7	Electro Static Discharge (operation)	C=150pF,R=330Ω; Contact:±4Kv, 5times; Air: ± 8KV,5times;	IEC61000-4-2:2001 GB/T17626.2-2006
8	Vibration (non-operation)	Frequency range:10 ~ 55Hz, Stroke:1.5mm Sweep:10Hz ~ 55Hz ~ 10Hz 2hours for each direction of X.Y.Z (6 hours total)	IEC60068-2-6:1982 GB/T2423.10—1995
9	Shock (non-operation)	60G 6ms, ±X,±Y,±Z 3 times for each direction	IEC60068-2-27:1987 GB/T2423.5—1995
10	Package Drop Test	Height:80 cm,1 corner, 3 edges, 6 surfaces	IEC60068-2-32:1990 GB/T2423.8—1995

Note1: Ts is the temperature of panel's surface.

Note2: Ta is the ambient temperature of sample.



8 Mechanical Drawing

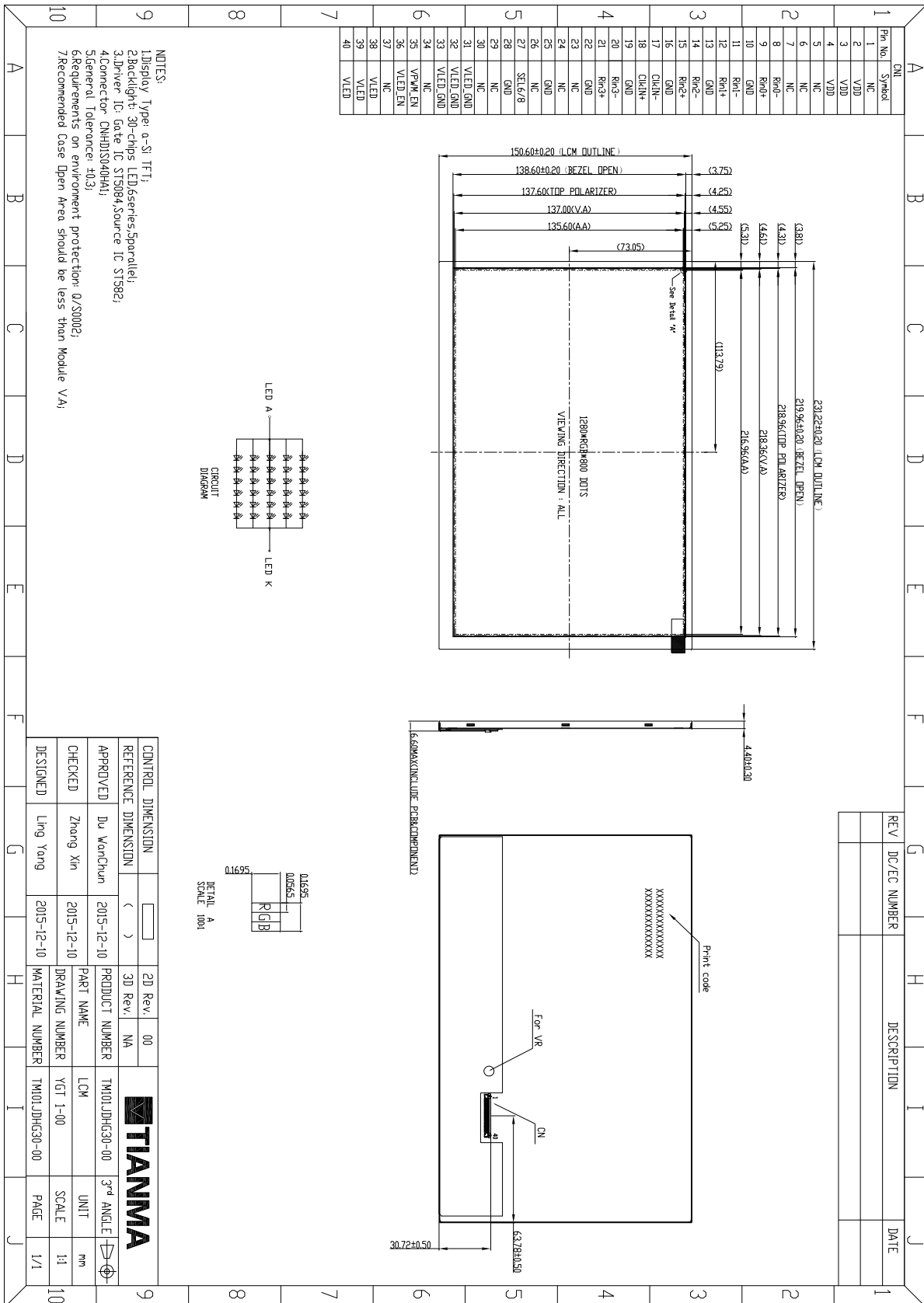

The information contained herein is the exclusive property of SHANGHAI TIANMA MICRO-ELECTRONICS Corporation, and shall not be distributed, reproduced, or disclosed in whole or in part without prior written permission of SHANGHAI TIANMA MICRO-ELECTRONICS Corporation.



## 9 Packing Drawing

No	Item	Model (Material)	Dimensions(mm)	Unit Weight(Kg)	Quantity	Remark
1	LCM module	TM101JDHG30	231.22x150.60x4.30	0.28	19	
2	Dust-Proof Bag	PE	700×545mm	0.046	1	
3	Anti-Static Bag	PE	246×240mm	0.004	1	
4	Partition_1	Corrugated paper	527×348×217mm	1.571	1	
5	Partition_2	Corrugated Paper	505×332×5mm	0.098	2	
6	Corrugated Bar	Corrugated Paper	527×244×7mm	0.057	2	
7	Carton	Corrugated paper	544×365×250mm	1.12	1	
8	Total weight(Kg)	8.371kg ± 5%				

The packing method is shown as below:

### 9.1 Put module into anti-static bag

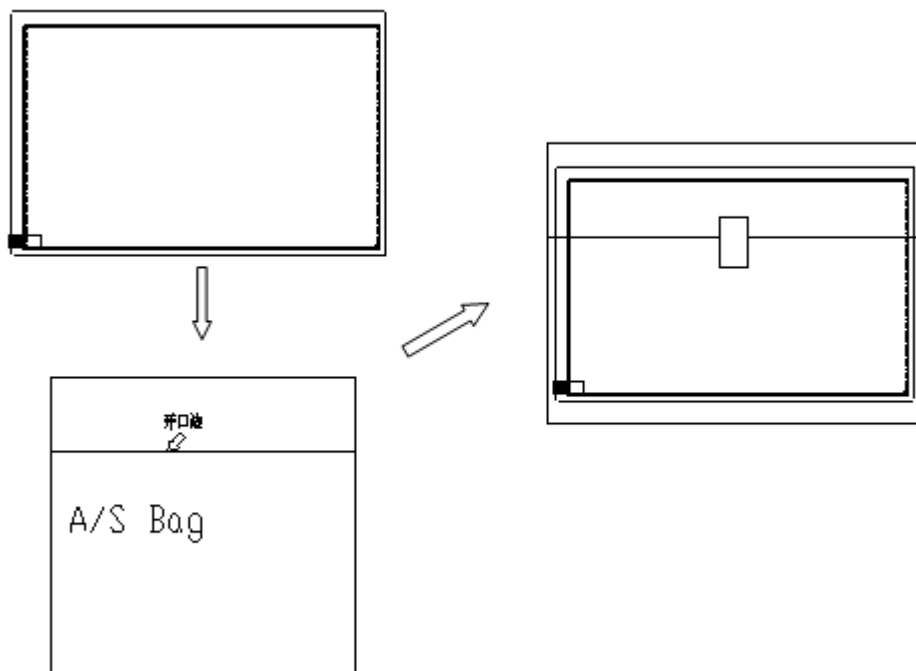



9.2 Dummy packing assembling

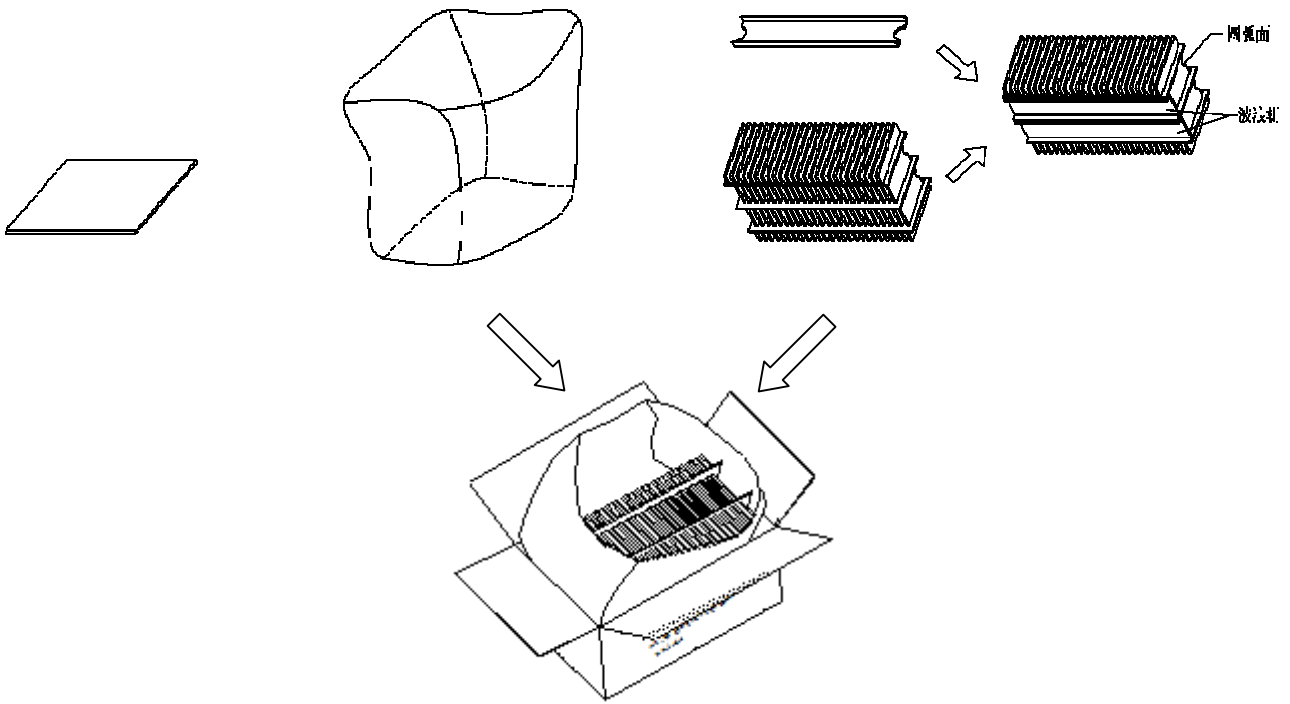

9.3 LCD module assembling

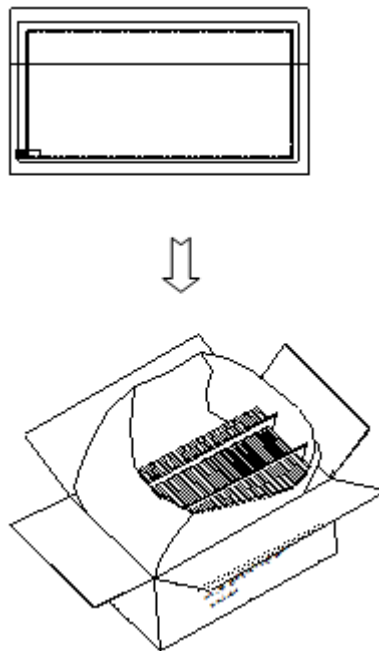



9.4 Box sealent

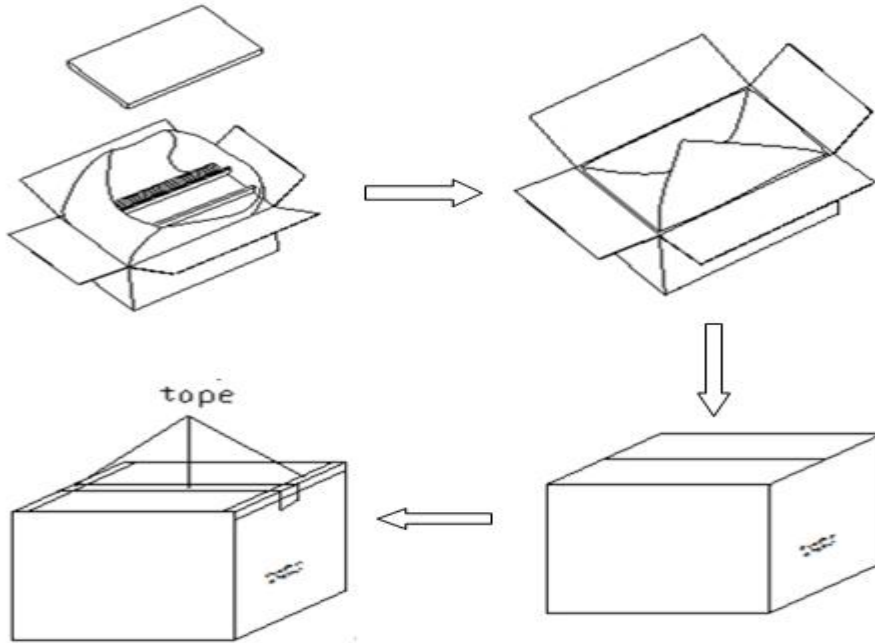

9.5 Stacking method(2x3x5)

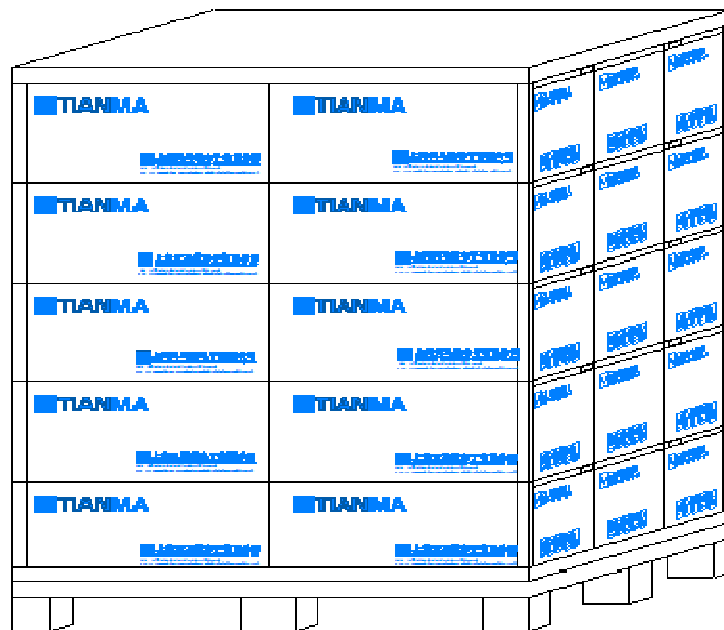



## 10 Precautions For Use of LCD Modules

### 10.1 Handling Precautions

- 10.1.1 The display panel is made of glass. Do not subject it to a mechanical shock by dropping it from a high place, etc.
- 10.1.2 If the display panel is damaged and the liquid crystal substance inside it leaks out, be sure not to get any in your mouth, if the substance comes into contact with your skin or clothes, promptly wash it off using soap and water.
- 10.1.3 Do not apply excessive force to the display surface or the adjoining areas since this may cause the color tone to vary.
- 10.1.4 The polarizer covering the display surface of the LCD module is soft and easily scratched. Handle this polarizer carefully.
- 10.1.5 If the display surface is contaminated, breathe on the surface and gently wipe it with a soft dry cloth. If still not completely clear, moisten cloth with one of the following solvents:
  - Isopropyl alcohol
  - Ethyl alcoholSolvents other than those mentioned above may damage the polarizer. Especially, do not use the following:
  - Water
  - Ketone
  - Aromatic solvents
- 10.1.6 Do not attempt to disassemble the LCD Module.
- 10.1.7 If the logic circuit power is off, do not apply the input signals.
- 10.1.8 To prevent destruction of the elements by static electricity, be careful to maintain an optimum work environment.
  - 10.1.8.1 Be sure to ground the body when handling the LCD Modules.
  - 10.1.8.2 Tools required for assembly, such as soldering irons, must be properly ground.
  - 10.1.8.3 To reduce the amount of static electricity generated, do not conduct assembly and other work under dry conditions.
  - 10.1.8.4 The LCD Module is coated with a film to protect the display surface. Be care when peeling off this protective film since static electricity may be generated.

### 10.2 Storage Precautions

- 10.2.1 When storing the LCD modules, avoid exposure to direct sunlight or to the light of fluorescent lamps.
- 10.2.2 The LCD modules should be stored under the storage temperature range. If the LCD modules will be stored for a long time, the recommend condition is:  
Temperature : 0°C ~ 40°C      Relatively humidity: ≤80%
- 10.2.3 The LCD modules should be stored in the room without acid, alkali and harmful gas.

### 10.3 Transportation Precautions

The LCD modules should be no falling and violent shocking during transportation, and also should avoid excessive press, water, damp and sunshine.