

# KOE

---

## JDI Group

Kaohsiung Opto-Electronics Inc.

FOR MESSRS : \_\_\_\_\_

DATE : Aug 30<sup>th</sup>, 2016

### CUSTOMER'S ACCEPTANCE SPECIFICATIONS

## TX09D30VM1CCA

### Contents

No.	ITEM	SHEET No.	PAGE
1	COVER	7B64PS 2701-TX09D30VM1CCA-4	1-1/1
2	RECORD OF REVISION	7B64PS 2702-TX09D30VM1CCA-4	2-1/2~2/2
3	GENERAL DATA	7B64PS 2703-TX09D30VM1CCA-4	3-1/1
4	ABSOLUTE MAXIMUM RATINGS	7B64PS 2704-TX09D30VM1CCA-4	4-1/1
5	ELECTRICAL CHARACTERISTICS	7B64PS 2705-TX09D30VM1CCA-4	5-1/1
6	OPTICAL CHARACTERISTICS	7B64PS 2706-TX09D30VM1CCA-4	6-1/2~2/2
7	BLOCK DIAGRAM	7B64PS 2707-TX09D30VM1CCA-4	7-1/1
8	RELIABILITY TESTS	7B64PS 2708-TX09D30VM1CCA-4	8-1/1
9	LCD INTERFACE	7B64PS 2709-TX09D30VM1CCA-4	9-1/6~6/6
10	OUTLINE DIMENSIONS	7B64PS 2710-TX09D30VM1CCA-4	10-1/1
11	TOUCH PANEL	7B64PS 2711-TX09D30VM1CCA-4	11-1/2~2/2
12	APPEARANCE STANDARD	7B64PS 2712-TX09D30VM1CCA-4	12-1/4~4/4
13	PRECAUTIONS	7B64PS 2713-TX09D30VM1CCA-4	13-1/2~2/2
14	DESIGNATION OF LOT MARK	7B64PS 2714-TX09D30VM1CCA-4	14-1/1

ACCEPTED BY: \_\_\_\_\_

PROPOSED BY: *Oblack Tsai*

## RECORD OF REVISION

DATE	SHEET No.	SUMMARY																																																			
May 01,'12	All pages	Company name changed: KAOHSIUNG HITACHI ELECTRONICS CO.,LTD. ↓ KAOHSIUNG OPTO-ELECTRONICS INC.																																																			
	7B64PS 2704 – TX09D30VM1CCA-2 Page 4 - 1/1	4. ABSOLUTE MAXIMUM RATINGS Revised : Note2																																																			
	7B64PS 2711 – TX09D30VM1CCA-2 Page 11 - 2/2	11.5 SAFETY AND ATTENTIONS Added : Item 4)																																																			
Mar 01,'13	7B64PS 2711 – TX09D30VM1CCA-3 Page 11 - 1/2	11.2 ELECTRICAL CHARACTERISTICS Revised : Fig11.1 dimensions 1mm → 2mm																																																			
	7B64PS 2714 – TX09D30VM1CCA-3 Page 14 - 1/1	14.3 REVISION (REV.) CONTROL Added : <table border="1" style="width: 100%; border-collapse: collapse; margin-top: 5px;"> <thead> <tr> <th style="width: 33%;">REV. No</th> <th style="width: 33%;">ITEM</th> <th style="width: 33%;">NOTE</th> </tr> </thead> <tbody> <tr> <td style="text-align: center;">A</td> <td style="text-align: center;">-</td> <td style="text-align: center;">-</td> </tr> <tr> <td style="text-align: center;">B</td> <td>Film of TP change</td> <td style="text-align: center;">PCN0852</td> </tr> </tbody> </table>	REV. No	ITEM	NOTE	A	-	-	B	Film of TP change	PCN0852																																										
REV. No	ITEM	NOTE																																																			
A	-	-																																																			
B	Film of TP change	PCN0852																																																			
Aug.30,'16	7B64PS 2703 – TX09D30VM1CCA-4 Page 3 - 1/1	3.1 DISPLAY FEATURES Revised : Power Consumption 0.4W → 0.33W																																																			
	7B64PS 2704 – TX09D30VM1CCA-4 Page 4 - 1/1	4. ABSOLUTE MAXIMUM RATINGS Revised : LED Backlight Forward Current IF=35mA → 30mA Revised : Note 3 、 Note 4 、 Fig 4.1																																																			
	7B64PS 2705 – TX09D30VM1CCA-4 Page 5 - 1/1	5.1 LCD CHARACTERISTICS Revised : <table border="1" style="width: 100%; border-collapse: collapse; margin-top: 5px;"> <thead> <tr> <th style="width: 50%;">Item</th> <th style="width: 15%;">Typ.</th> <th style="width: 15%;">Max.</th> </tr> </thead> <tbody> <tr> <td>Power Supply Current</td> <td style="text-align: center;">120</td> <td style="text-align: center;">145</td> </tr> </tbody> </table> <p style="text-align: center;">↓</p> <table border="1" style="width: 100%; border-collapse: collapse; margin-top: 5px;"> <thead> <tr> <th style="width: 50%;">Item</th> <th style="width: 15%;">Typ.</th> <th style="width: 15%;">Max.</th> </tr> </thead> <tbody> <tr> <td>Power Supply Current</td> <td style="text-align: center;">100</td> <td style="text-align: center;">120</td> </tr> </tbody> </table> 5.2 BACKLIGHT CHARACTERISTICS Revised : <table border="1" style="width: 100%; border-collapse: collapse; margin-top: 5px;"> <thead> <tr> <th style="width: 30%;">Item</th> <th style="width: 30%;">Condition</th> <th style="width: 10%;">Typ.</th> <th style="width: 10%;">Max.</th> </tr> </thead> <tbody> <tr> <td>LED Input Voltage</td> <td>IF=12mA</td> <td style="text-align: center;">3.2</td> <td style="text-align: center;">3.5</td> </tr> <tr> <td>LED Forward Current</td> <td>Backlight Unit</td> <td style="text-align: center;">12</td> <td style="text-align: center;">-</td> </tr> <tr> <td>LED Reverse Current</td> <td>VR=5V</td> <td style="text-align: center;">50</td> <td style="text-align: center;">-</td> </tr> <tr> <td>LED Life Time</td> <td>IF=12mA</td> <td style="text-align: center;">40</td> <td style="text-align: center;">-</td> </tr> </tbody> </table> <p style="text-align: center;">↓</p> <table border="1" style="width: 100%; border-collapse: collapse; margin-top: 5px;"> <thead> <tr> <th style="width: 30%;">Item</th> <th style="width: 30%;">Condition</th> <th style="width: 10%;">Typ.</th> <th style="width: 10%;">Max.</th> </tr> </thead> <tbody> <tr> <td>LED Input Voltage</td> <td>IF=10mA</td> <td style="text-align: center;">3.2</td> <td style="text-align: center;">3.5</td> </tr> <tr> <td>LED Forward Current</td> <td>Backlight Unit</td> <td style="text-align: center;">10</td> <td style="text-align: center;">-</td> </tr> <tr> <td>LED Reverse Current</td> <td>VR=5V</td> <td style="text-align: center;">-</td> <td style="text-align: center;">10</td> </tr> <tr> <td>LED Life Time</td> <td>IF=10mA</td> <td style="text-align: center;">40</td> <td style="text-align: center;">-</td> </tr> </tbody> </table>	Item	Typ.	Max.	Power Supply Current	120	145	Item	Typ.	Max.	Power Supply Current	100	120	Item	Condition	Typ.	Max.	LED Input Voltage	IF=12mA	3.2	3.5	LED Forward Current	Backlight Unit	12	-	LED Reverse Current	VR=5V	50	-	LED Life Time	IF=12mA	40	-	Item	Condition	Typ.	Max.	LED Input Voltage	IF=10mA	3.2	3.5	LED Forward Current	Backlight Unit	10	-	LED Reverse Current	VR=5V	-	10	LED Life Time	IF=10mA	40
Item	Typ.	Max.																																																			
Power Supply Current	120	145																																																			
Item	Typ.	Max.																																																			
Power Supply Current	100	120																																																			
Item	Condition	Typ.	Max.																																																		
LED Input Voltage	IF=12mA	3.2	3.5																																																		
LED Forward Current	Backlight Unit	12	-																																																		
LED Reverse Current	VR=5V	50	-																																																		
LED Life Time	IF=12mA	40	-																																																		
Item	Condition	Typ.	Max.																																																		
LED Input Voltage	IF=10mA	3.2	3.5																																																		
LED Forward Current	Backlight Unit	10	-																																																		
LED Reverse Current	VR=5V	-	10																																																		
LED Life Time	IF=10mA	40	-																																																		

## RECORD OF REVISION

DATE	SHEET No.	SUMMARY
Aug.30,'16	7B64PS 2706 – TX09D30VM1CCA-4 Page 6 - 1/2	6. OPTICAL CHARACTERISTICS Revised : Condition ILED=12mA → 10mA
	7B64PS 2711 – TX09D30VM1CCA-4 Page 11 - 1/2	11.2 ELECTRICAL CHARACTERISTICS Revised : X1-X2 : 200~650Ω → 100~750Ω Y1-Y2 : 250~500Ω → 310~950Ω
	7B64PS 2711 – TX09D30VM1CCA-4 Page 11 - 2/2	11.3 MECHANICAL CHARACTERISTICS Revised : Surface Hardness JIS K 5400 → JIS K-5600-5-4

### 3. GENERAL DATA

#### 3.1 DISPLAY FEATURES

This module is a 3.5" QVGA TFT with 3 by 4 format, which is composed of amorphous silicon. Each sub-pixel (dot) on the LCD is vertical stripe type arranged as R (red), G (green), B (blue) color sequentially. The bounding technology, COG (chip on glass), and LED backlight design have been applied on this display RoHS compliant.

Part Name	TX09D30VM1CCA
Module Dimensions	64.0(W) mm x 86.0(H) mm x 7.6(D) mm typ.
LCD Active Area	53.64(W) mm x 71.52(H) mm
Dot Pitch	0.0745(W) mm x 3(R, G, B)(W) x 0.2235(H) mm
Resolution	240 x 3(RGB)(W) x 320(H) dots
Color Pixel Arrangement	R, G, B Vertical stripe
LCD Type	Transmissive Color TFT; Normally White
Display Type	Active Matrix
Number of Colors	262k Colors
Backlight	Light Emitting Diode (LED) x 6
Weight	40 g (typ.)
Interface	C-MOS; 18-bit RGB; 40 pins
Power Supply Voltage	3.3V (Including LCD ,Timing Controller and Backlight)
Power Consumption	0.33W
Viewing Direction	6 O'clock (No inversion of gray level scale and less change in brightness)
Touch Panel	Resistance type. The surface is anti-glare.

## 4. ABSOLUTE MAXIMUM RATINGS

Item	Symbol	Min.	Max.	Unit	Remarks	
Supply Voltage	$V_{CC}$	-0.3	3.6	V	-	
Input Voltage of Logic	$V_I$	0	$V_{CC}$	V	Note 1	
Operating Temperature	$T_{op}$	-20	70	$^{\circ}C$	Note 2	
Storage Temperature	$T_{st}$	-30	85	$^{\circ}C$	Note 2	
LED Backlight	Forward Current	$I_F$	-	30	mA	Note 3
	Pulse Forward Current	$I_{FP}$	-	100	mA	Note 4
	Reverse Voltage	$V_R$	-	5	V	LED unit

Note 1: The rating is defined for the signal voltages of the interface such as DTMG, DCLK and RGB data bus.

Note 2: The maximum rating is defined as above based on the chamber temperature, which might be different from ambient temperature after assembling the panel into the application. Moreover, some temperature-related phenomenon as below needed to be noticed:

- Background color, contrast and response time would be different from  $25^{\circ}C$ .
- Operating under high temperature will shorten LED lifetime.

Note 3: Fig. 4.1 shows the maximum rating of forward current based on different temperature for LED unit. Moreover, the backlight unit of this display has been set at 10 mA per LED, which is located at the allowable area when display is operated within  $T_{op}$ ,  $-20\sim 70^{\circ}C$ .

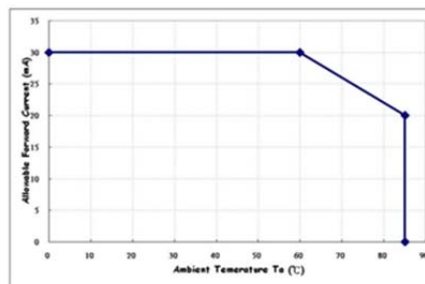
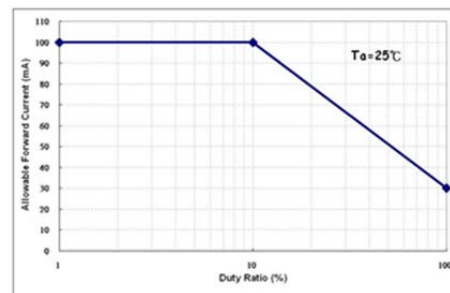
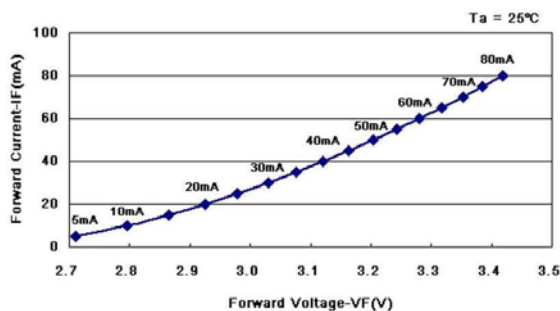

Fig. 4.1

Note 4: Fig. 4.2 and 4.3 show the LED characteristics of the relationship between  $V_F$  v.s.  $I_{FP}$  and  $I_{FP}$  v.s. Duty Ratio, which is related to dimming control of LED backlight. Either adjusting DC voltage or applying Pulse Width Modulation (PWM) signal is the method to have this functionality.



## 5. ELECTRICAL CHARACTERISTICS

### 5.1 LCD CHARACTERISTICS

Ta=25°C, V<sub>SS</sub>=0V

Item	Symbol	Condition	Min.	Typ.	Max.	Unit	Remarks
Power Supply Voltage	V <sub>CC</sub>	-	3.0	3.3	3.6	V	-
Input Voltage of Logic	V <sub>I</sub>	"H" level	0.8V <sub>CC</sub>	-	V <sub>CC</sub>	V	Note 1
		"L" level	V <sub>SS</sub>	-	0.2V <sub>CC</sub>		
Power Supply Current	I <sub>DD</sub>	V <sub>CC</sub> -V <sub>SS</sub> =3.0V	-	100	120	mA	Note 2
Vsync Frequency	FV	-	-	60	68	Hz	-
Hsync Frequency	FH	-	18.57	20.77	22.73	KHz	-
DCLK Frequency	FCLK	-	5.0	5.6	6.5	MHz	-

Note 1: The rating is defined for the signal voltages of the interface such as DCLK and RGB data bus.

Note 2: All black on the screen is the check pattern to measure IDD, which is based on FV=60 Hz.

### 5.2 BACKLIGHT CHARACTERISTICS

Ta=25°C

Item	Symbol	Condition	Min.	Typ.	Max.	Unit	Remarks
LED Input Voltage	V <sub>F</sub>	I <sub>F</sub> =10mA	-	3.2	3.5	V	LED/Part
LED Forward Current	I <sub>F</sub>	Backlight Unit	-	10	-	mA	LED/Part
LED Reverse Current	I <sub>R</sub>	V <sub>R</sub> =5V	-	-	10	μA	LED/Part
LED Current Control	PWM	(V <sub>IN</sub> =3.3V)	1	-	30	KHz	(Note1)
LED Life Time	-	I <sub>F</sub> =10mA	-	40	-	Khr	

Note 1: PWM's frequency, 1KHz ~ 30KHz, is recommended.

## 6. OPTICAL CHARACTERISTICS

The optical characteristics are measured based on the conditions as below:

- Supplying the signals and voltages defined in the section of electrical characteristics.
- The backlight unit needs to be turned on after 30 minutes.
- The ambient temperature is 25°C.
- In the dark room around 500~1000 lx, the equipment has been set for the measurements as shown in Fig 6.1.

Ta=25°C, FV=60Hz, V<sub>CC</sub>=3.3V

Item	Symbol	Condition	Min.	Typ.	Max.	Unit	Remarks
Brightness of white	B	$\phi = 0^\circ, \theta = 0^\circ$ $I_{LED} = 10 \text{ mA}$	200	250	-	cd/m <sup>2</sup>	Note 1
Brightness uniformity	-		70	-	-	%	Note 2
Contrast Ratio	CR		180	300	-	-	Note 3
Response time	RISE(Ton)	$\phi = 0^\circ, \theta = 0^\circ$	-	15	-	ms	Note 4
	FALL(Toff)		-	15	-		
NTSC Ratio	-	$\phi = 0^\circ, \theta = 0^\circ$	-	50	-	%	-
Viewing Angle	$\theta = X$	$\phi = 0^\circ, CR \geq 10$	60	70	-	Degree	Note 5
	$\theta = X'$	$\phi = 180^\circ, CR \geq 10$	60	70	-		
	$\theta = Y$	$\phi = 90^\circ, CR \geq 10$	70	80	-		
	$\theta = Y'$	$\phi = 270^\circ, CR \geq 10$	50	60	-		
Color chromaticity	Red	X	0.54	0.59	0.64	-	Note 6
		Y	0.29	0.34	0.39		
	Green	X	0.31	0.36	0.41		
		Y	0.51	0.56	0.61		
	Blue	X	0.10	0.15	0.20		
		Y	0.08	0.13	0.18		
	White	X	0.28	0.33	0.38		
		Y	0.29	0.34	0.39		

Note 1: The brightness is measured from the center point of the panel, P5 in Fig. 6.2, for the typical value.

Note 2: The brightness uniformity is calculated by the equation as below:

$$\text{Brightness uniformity} = \frac{\text{Min. Brightness}}{\text{Max. Brightness}} \times 100\%$$

, which is based on the brightness values of the 9 points measured by BM-5 as shown in Fig. 6.2.

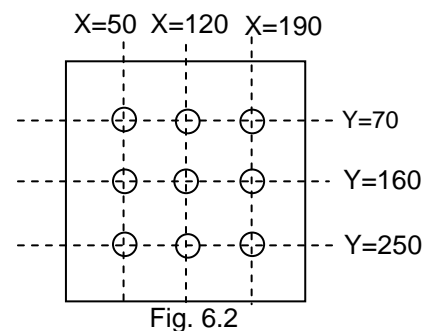
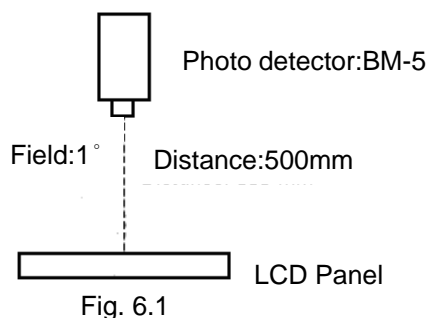

Note 3: The Contrast Ratio is measured from the center point of the panel, P5, and defined as the following equation:

$$CR = \frac{\text{Brightness of White}}{\text{Brightness of Black}}$$

Note 4: The definition of response time is shown in Fig. 6.3. Rising time is the period from 90% brightness down to 10% brightness when the data is from white turning to black. Oppositely, Falling time is the period from 10% brightness rising to 90% brightness.

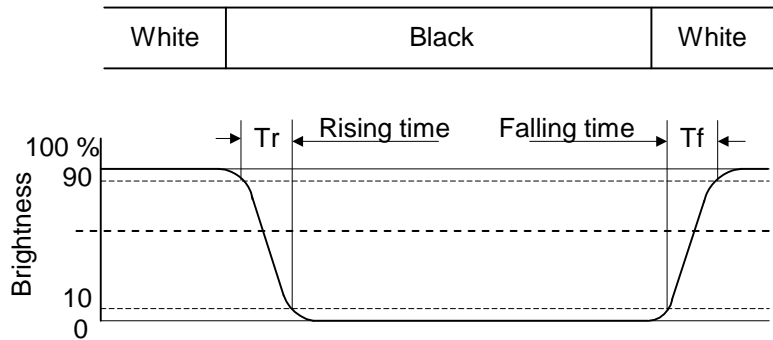

Fig . 6.3

Note 5: The definition of viewing angle is shown in Fig. 6.4. Angle  $\phi$  is used to represent viewing directions, for instance,  $\phi = 270^\circ$  means 6 o'clock, and  $\phi = 0^\circ$  means 3 o'clock. Moreover, angle  $\theta$  is used to represent viewing angles from axis Z toward plane XY.

The viewing direction of this display is 6 o'clock, which means that a photograph with gray scale would not be reversed in color and the brightness change would be less from this direction. However, the contrast peak would be located at 12 o'clock.

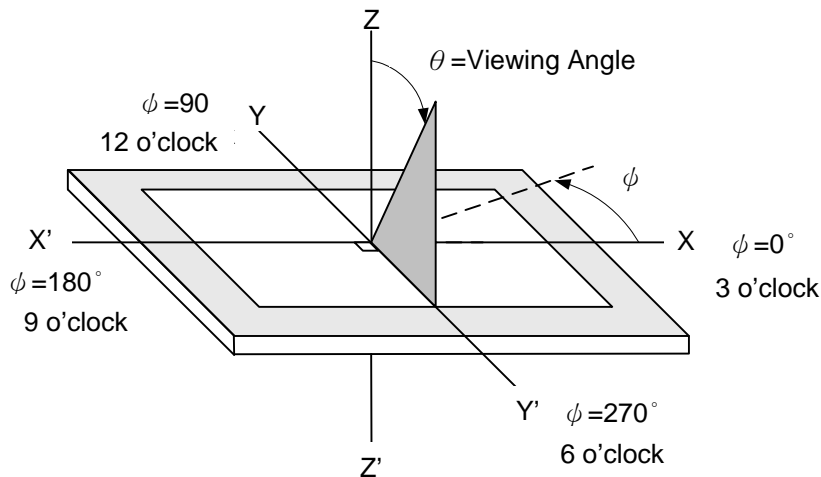
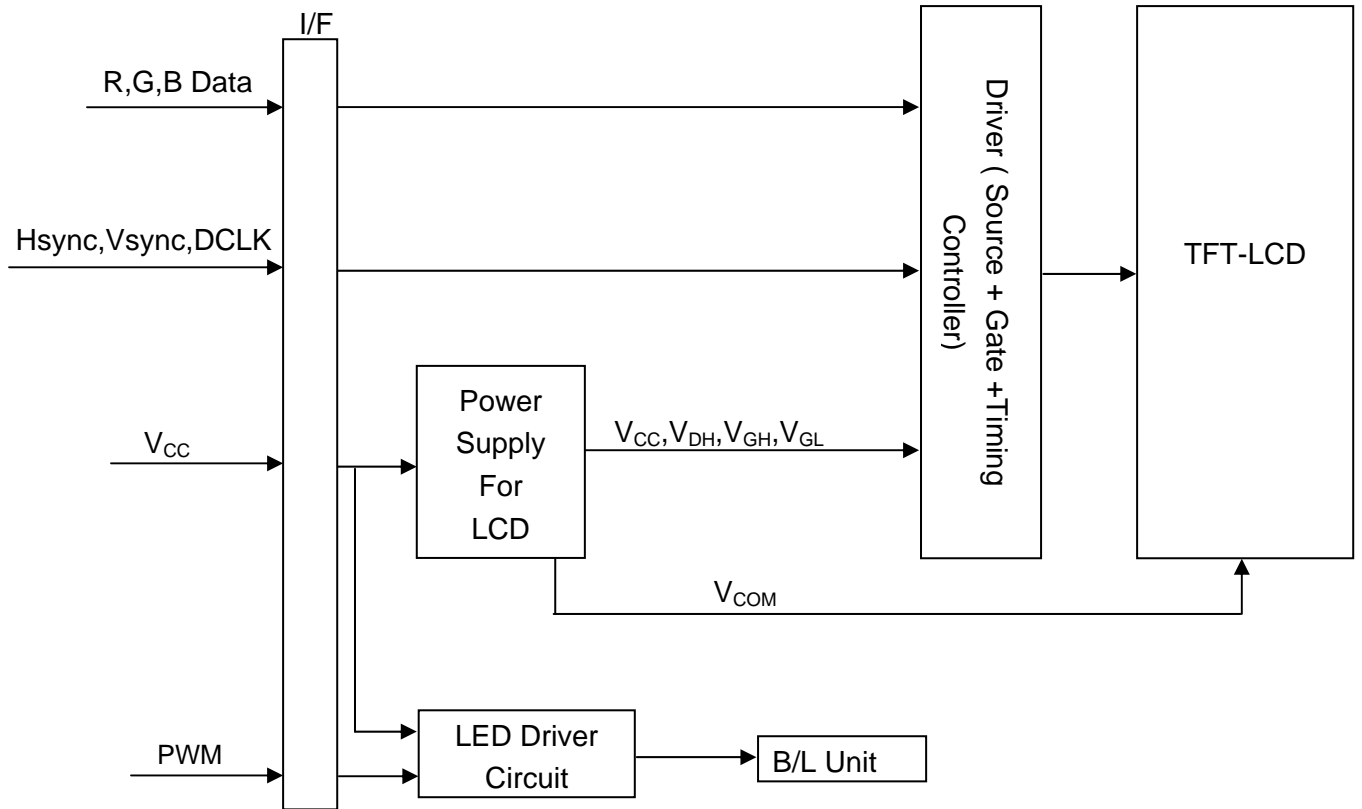

Fig. 6.4

Note 6: The color chromaticity is measured from the center point of the panel, P5, as shown in Fig. 6.2.



# 7. BLOCK DIAGRAM



## 8. RELIABILITY TESTS

Test Item	Condition	
High Temperature	1) Operating 2) 70 °C	240 hrs
Low Temperature	1) Operating 2) -20 °C	240 hrs
High Temperature	1) Storage 2) 80 °C	240 hrs
Low Temperature	1) Storage 2) -30 °C	240 hrs
Heat Cycle	1) Operating 2) -20 °C ~70 °C 3) 3hrs~1hr~3hrs	240 hrs
Thermal Shock	1) Non-Operating 2) -35 °C ↔ 85 °C 3) 0.5 hr ↔ 0.5 hr	240 hrs
High Temperature & Humidity	1) Operating 2) 40 °C & 85%RH 3) Without condensation (Note 3)	240 hrs
Vibration	1) Non-Operating 2) 20~200 Hz 3) 3G 4) X, Y, and Z directions	1 hr for each direction
Mechanical Shock	1) Non-Operating 2) 10 ms 3) 50G 4) ±X, ±Y and ±Z directions	Once for each direction
ESD	1) Operating 2) Tip: 200 pF, 250 Ω 3) Air discharge for glass: ±8KV 4) Contact discharge for metal frame: ±8KV	1) Glass: 9 points 2) Metal frame: 8 points (Note4)

Note 1: Display functionalities are inspected under the conditions defined in the specification after the reliability tests.

Note 2: The display is not guaranteed for use in corrosive gas environments.

Note 3: Under the condition of high temperature & humidity, if the temperature is higher than 40°C, the humidity needs to be reduced as Fig. 8.1 shown.

Note 4: All pins of LCD interface(CN1) have been tested by ±100V contact discharge of ESD under non-operating condition.

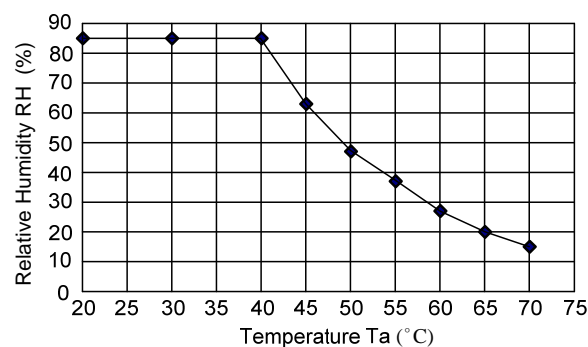

Fig. 8.1

## 9. LCD INTERFACE

### 9.1 INTERFACE PIN CONNECTIONS

The connector of display interface is FA5S040HP1R3000 made by JAE (Thickness:  $0.3 \pm 0.05\text{mm}$ ; Pitch:  $0.5 \pm 0.05\text{mm}$ ) and more details of the connector are shown in the section of outline dimension.

Pin assignment of LCD interface is as below:

Pin No.	Signal	Function	Pin No.	Signal	Function
1	V <sub>CC</sub>	Power Supply for Logic	21	G4	Green Data
2	V <sub>CC</sub>		22	G3	
3	V <sub>CC</sub>		23	V <sub>SS</sub>	GND
4	DCLK	Dot Clock	24	G2	Green Data
5	GND	GND	25	G1	
6	HSYNC	Horizontal Sync Pulse	26	G0	
7	NC	No Connection	27	V <sub>SS</sub>	GND
8	GND	GND	28	B5	Blue Data
9	V <sub>SS</sub>	GND	29	B4	
10	VSYNC	Vertical Sync Pulse	30	B3	
11	V <sub>SS</sub>	GND	31	V <sub>SS</sub>	GND
12	R5	RED DATA	32	B2	Blue Data
13	R4		33	B1	
14	R3		34	B0	
15	V <sub>SS</sub>	GND	35	NC	No connection
16	R2	RED DATA	36	PWM	LED Current Control
17	R1		37	xR	Touch Panel Right Side
18	R0		38	yL	Touch Panel Lower Side
19	V <sub>SS</sub>	GND	39	xL	Touch Panel Left Side
20	G5	Green Data	40	yU	Touch Panel Upper Side

## 9.2 TIMING CHART

	SYMBOL	MIN.	TYP.	MAX.	UNIT
Back porch for Horizontal	HBP	12	12	12	Clock
Front porch for Horizontal	HFP	15	18 Note1	21	Clock
Back porch for Vertical	VBP	8	8	8	SYNC Note3
Front porch for Vertical	VFP	17	20 Note2	22	HSYNC

Note 1 : (DOTCLK total) - ((Valid data period for Horizontal) + (HBP))

Note 2 : (HSYNC total) - ((Active Area period) + VBP)

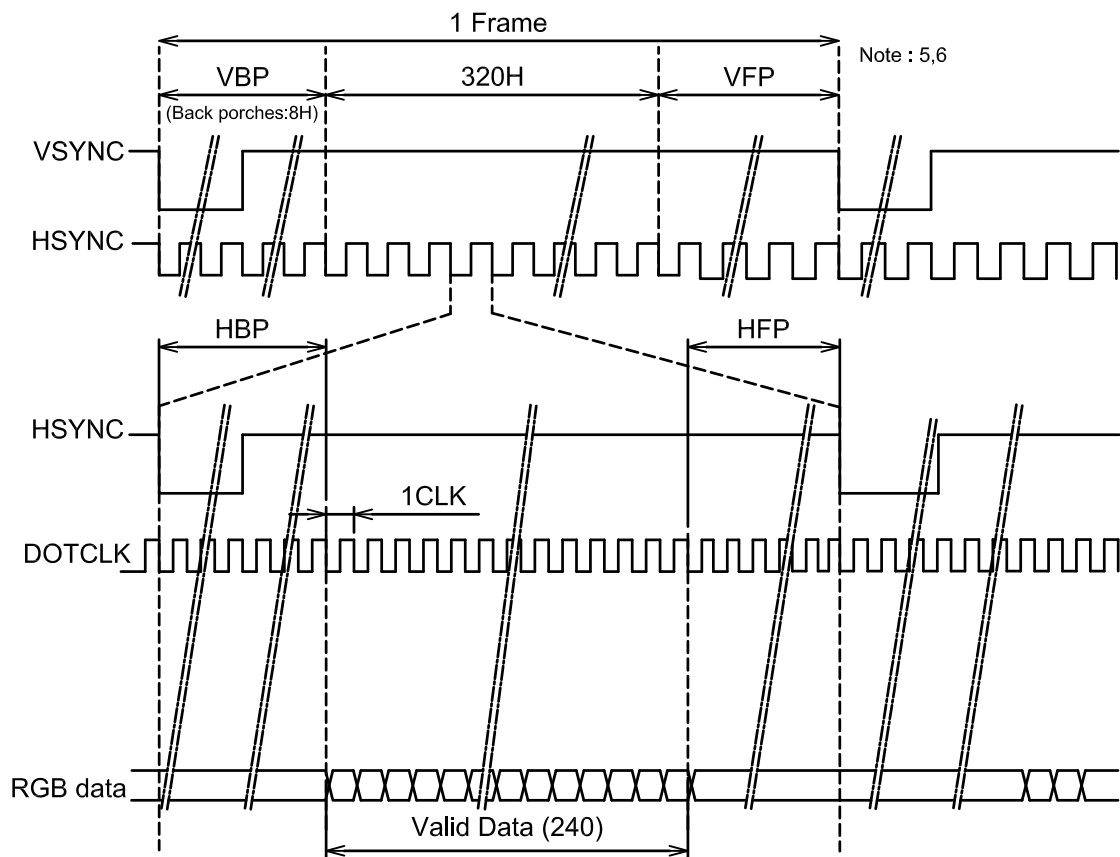

Note 3 : Note about VSYNC timing setting

Check the timing chart of VSYNC and HSYNC , If timing setting is not set as Fig1, it must be set as Fig2 .

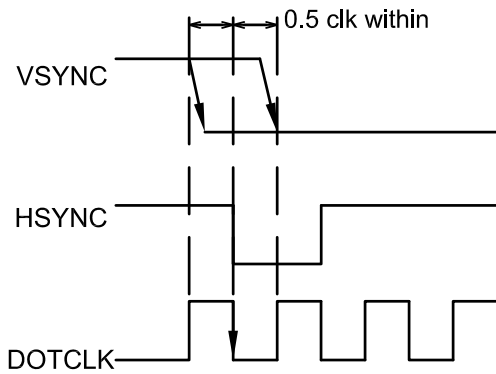

Fig1. VSYNC timing

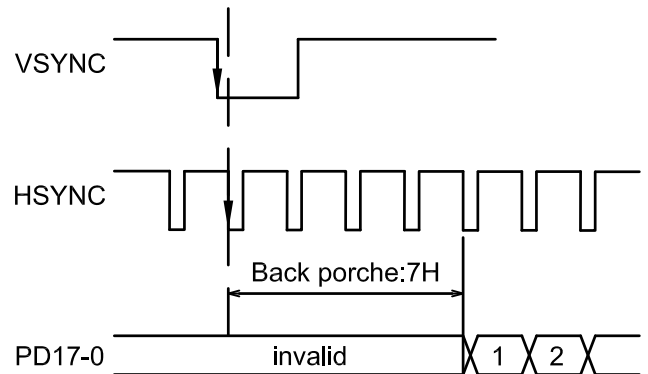

Fig2. Vertical back porch regulation

Note 4 : The DOTCLK signal must be supplied consecutively.

Note 5 : Front and back porches (VBP , VFP) must be set before and after the display operation period.

Note 6 : The front porch period continues until the next input of VSYNC signal.



### 9.3 INTERFACE TIMING SPECIFICATIONS

ITEM	SYMBOL	MIN.	TYP.	MAX.	UNIT	REMARKS
DOTCLK cycle time	tCYCD	100	-	-	ns	1 trans
		50	-	-		3 trans
DOTCLK low level pulse width	PWDL	20	-	-	ns	-
DOTCLK high level pulse width	PWDH	20	-	-	ns	-
VSYNC setup time	tVSYNCS	0	-	1	clock	-
HSYNC setup time	tHSYNCS	0	-	1	clock	-
RGB data setup time	TPDS	20	-	-	ns	-
RGB data hold time	TPDH	20	-	-	ns	-
DOTCLK/VSYNC/HSYNC rising edge, falling edge times	trgbr / trgbf	-	-	20	ns	-

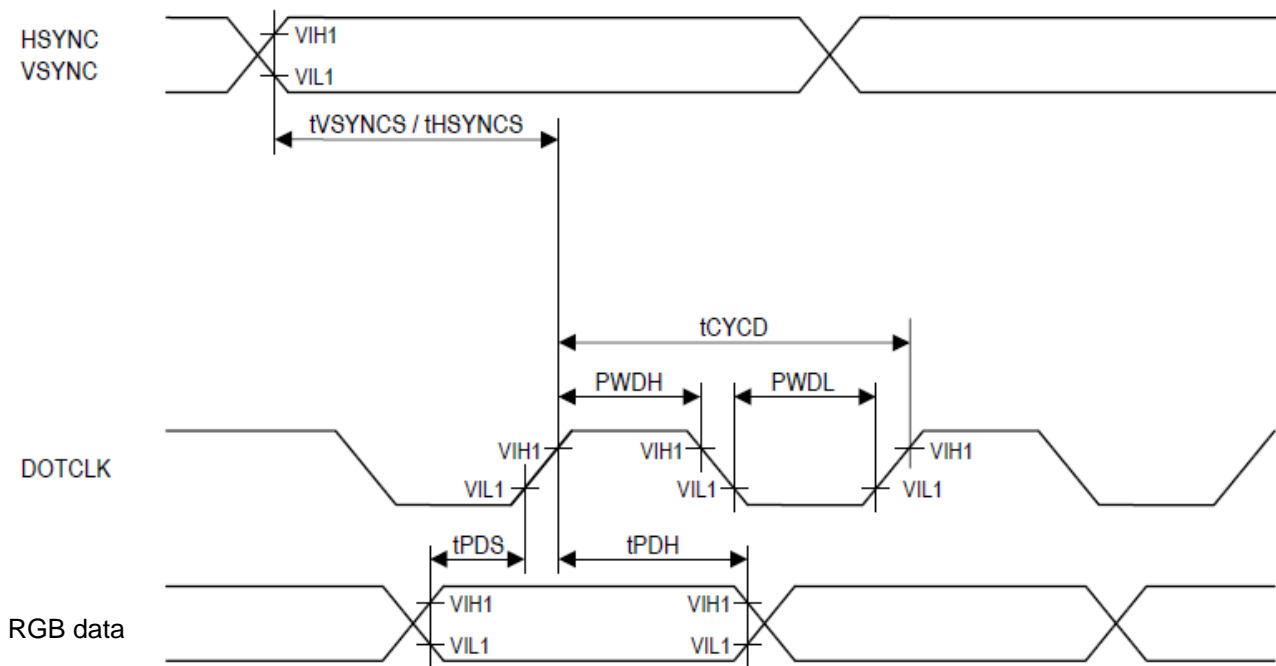

**Fig3. RGB Interface timing**

## 9.4 POWER SEQUENCE

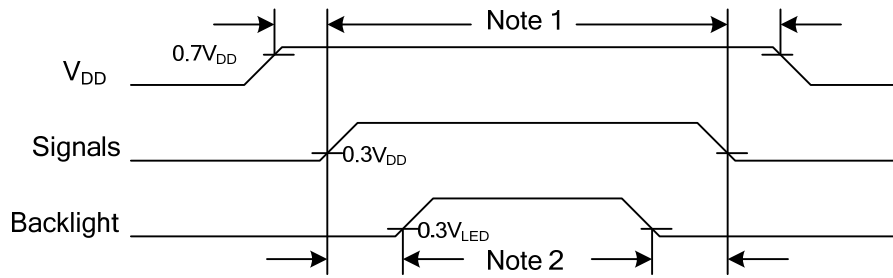

Fig. 9.4 Power Sequence Timing

Note 1: In order to avoid any damages,  $V_{DD}$  has to be applied before all other signals. The opposite is true for power Off where  $V_{DD}$  has to be remained on until all other signals have been switch off. The recommended time period is 0.5 second.

Note 2: In order to avoid showing uncompleted patterns in transient state. It is recommended that switching the backlight on is delayed for 0.5 second after the signals have been applied. The opposite is true for power Off where the backlight has to be switched off 0.5 second before the signals are removed.

### 9.5 DATA INPUT for DISPLAY COLOR

	COLOR & Gray Scale	Data Signal																	
		R5	R4	R3	R2	R1	R0	G5	G4	G3	G2	G1	G0	B5	B4	B3	B2	B1	B0
Basic Color	Black	0	0	0	0	0	0	0	0	0	0	0	0	0	0	0	0	0	0
	Red (0)	1	1	1	1	1	1	0	0	0	0	0	0	0	0	0	0	0	0
	Green (0)	0	0	0	0	0	0	1	1	1	1	1	1	0	0	0	0	0	0
	Blue (0)	0	0	0	0	0	0	0	0	0	0	0	0	1	1	1	1	1	1
	Cyan	0	0	0	0	0	0	1	1	1	1	1	1	1	1	1	1	1	1
	Magenta	1	1	1	1	1	1	0	0	0	0	0	0	1	1	1	1	1	1
	Yellow	1	1	1	1	1	1	1	1	1	1	1	1	0	0	0	0	0	0
	White	1	1	1	1	1	1	1	1	1	1	1	1	1	1	1	1	1	1
Red	Black	0	0	0	0	0	0	0	0	0	0	0	0	0	0	0	0	0	0
	Red (62)	0	0	0	0	0	1	0	0	0	0	0	0	0	0	0	0	0	0
	Red (61)	0	0	0	0	1	0	0	0	0	0	0	0	0	0	0	0	0	0
	:	:	:	:	:	:	:	:	:	:	:	:	:	:	:	:	:	:	:
	:	:	:	:	:	:	:	:	:	:	:	:	:	:	:	:	:	:	:
	Red (1)	1	1	1	1	1	0	0	0	0	0	0	0	0	0	0	0	0	0
	Red (0)	1	1	1	1	1	1	0	0	0	0	0	0	0	0	0	0	0	0
Green	Black	0	0	0	0	0	0	0	0	0	0	0	0	0	0	0	0	0	0
	Green (62)	0	0	0	0	0	0	0	0	0	0	0	1	0	0	0	0	0	0
	Green (61)	0	0	0	0	0	0	0	0	0	0	0	1	0	0	0	0	0	0
	:	:	:	:	:	:	:	:	:	:	:	:	:	:	:	:	:	:	:
	:	:	:	:	:	:	:	:	:	:	:	:	:	:	:	:	:	:	:
	Green (1)	0	0	0	0	0	0	1	1	1	1	1	1	0	0	0	0	0	0
	Green (0)	0	0	0	0	0	0	1	1	1	1	1	1	0	0	0	0	0	0
Blue	Black	0	0	0	0	0	0	0	0	0	0	0	0	0	0	0	0	0	0
	Blue (62)	0	0	0	0	0	0	0	0	0	0	0	0	0	0	0	0	0	1
	Blue (61)	0	0	0	0	0	0	0	0	0	0	0	0	0	0	0	0	1	0
	:	:	:	:	:	:	:	:	:	:	:	:	:	:	:	:	:	:	:
	:	:	:	:	:	:	:	:	:	:	:	:	:	:	:	:	:	:	:
	Blue (1)	0	0	0	0	0	0	0	0	0	0	0	0	1	1	1	1	1	0
Blue (0)	0	0	0	0	0	0	0	0	0	0	0	0	1	1	1	1	1	1	



# 10. OUTLINE DIMENSIONS

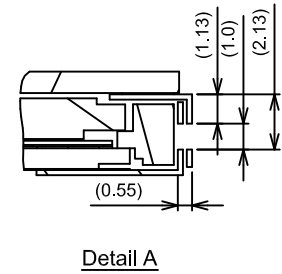
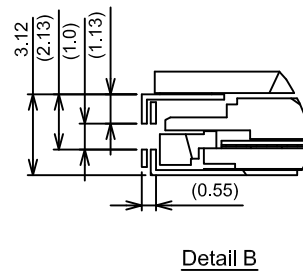
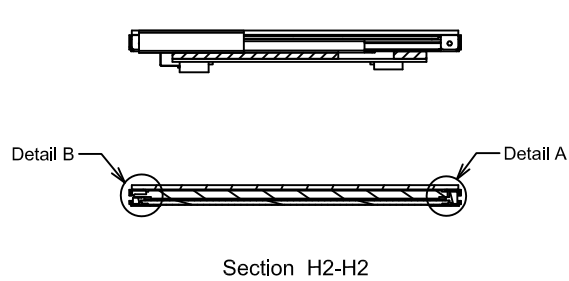
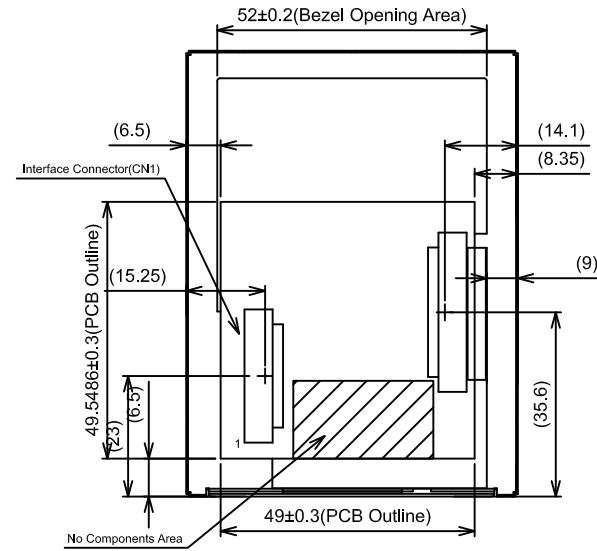
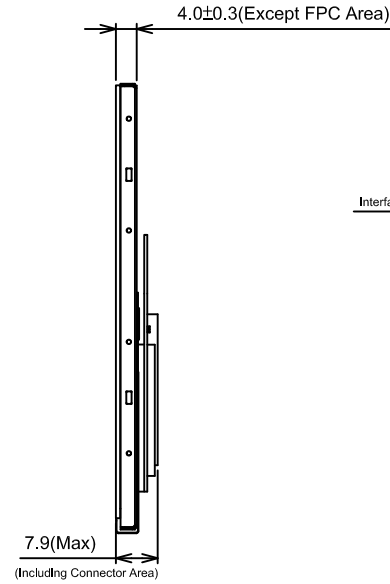
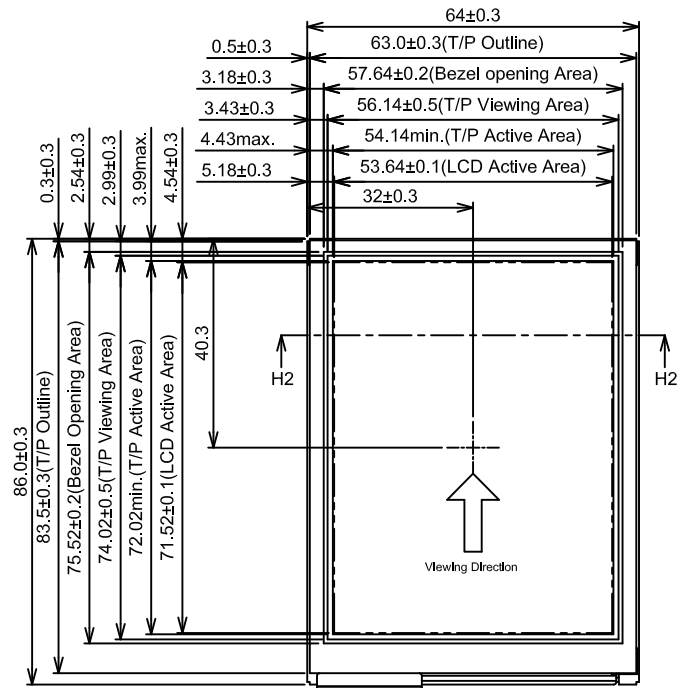

Scale : NTS  
Unit : mm

# 11. TOUCH PANEL

The type of touch panel used on this display is resistive, analog, 4-wire and film on glass, and more characteristics are shown as below:

## 11.1 OPERATING CONDITIONS

Item	Specification	Remarks
Operating Voltage	5VDC	7V MAX

## 11.2 ELECTRICAL CHARACTERISTICS

Item	Specification	Remarks
Resistance Between Terminal	X1-X2 Y1-Y2	100~750Ω 310~950Ω
Insulation Resistance	X-Y	20MΩ min. At 25V DC
Linearity	X Y	±1.5% max. ±1.5% max. Note 1
Chattering		10ms max. -

Note 1: The test conditions and equipments of linearity are as below:

- Material of pen: poly-acetal resin
- End shape: R 0.8 mm
- Test force: 80 g
- Pitch: 10 mm
- Test area is shown in Fig. 11.1

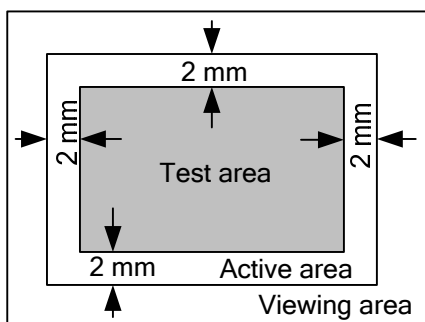

Fig. 11.1

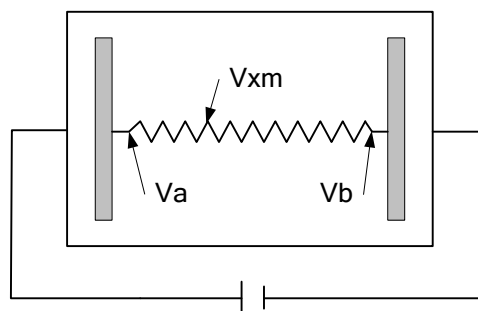

Fig. 11.2

As shown in Fig. 11.2, applying voltage meter to measure  $V_a$ ,  $V_b$  and  $V_{xm}$ , where  $V_a$  is the maximum voltage in the active area;  $V_b$  is the minimum voltage in the active area;  $V_{xm}$  is the measured voltage of point x selected by random. Afterwards, the linearity can be calculated by following equation:

$$\text{Linearity} = \frac{|V_{xi} - V_{xm}|}{V_a - V_b} \times 100\%$$

where  $V_{xi}$  is the idea voltage of point x.

The method to measure the linearity of Y-axis is the same as above.

### 11.3 MECHANICAL CHARACTERISTICS

Item	Specification	Remarks
Pen Input Pressure	20~80g	R0.8, Polyacetal Pen
Surface Hardness	3H min.	JIS K-5600-5-4

### 11.4 OPTICAL CHARACTERISTICS

Item	Specification	Remarks
Transmittance	80% min.	-

### 11.5 SAFETY AND ATTENTIONS

- 1) Do not put heavy shock or stress on the touch panel.
- 2) Please use soft cloth or absorbent cotton with ethanol to clean the touch panel by gently wiping. Moreover, please wipe it by horizontal or vertical direction instead of circling to prevent leaving scars on the touch panel's surface.
- 3) Do not use any harmful chemicals such as acetone, toluene, and isopropyl alcohol to clean the display's surface.
- 4) UV protection is recommended to avoid the possibility of performance degrading when touch panel is likely applied under UV environment for a long period of time.

## 12. APPEARANCE STANDARD

The appearance inspection is performed in a dark room around 500~1000 lx based on the conditions as below:

- The distance between inspector's eyes and display is 30 cm.
- The viewing zone is defined with angle  $\theta$  shown in Fig. 11.1 The inspection should be performed within  $45^\circ$  when display is shut down. The inspection should be performed within  $5^\circ$  when display is power on.

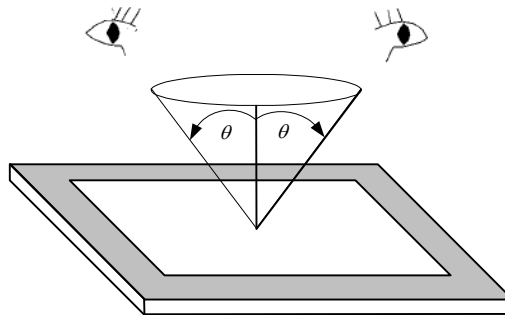

Fig. 11.1

### 12.1 THE DEFINITION OF LCD ZONE

LCD panel is divided into 3 areas as shown in Fig.11.2 for appearance specification in next section. A zone is the LCD active area (dot area); B zone is the area, which extended 1 mm out from LCD active area; C zone is the area between B zone and metal frame.

In terms of housing design, B zone is the recommended window area customers' housing should be located in.

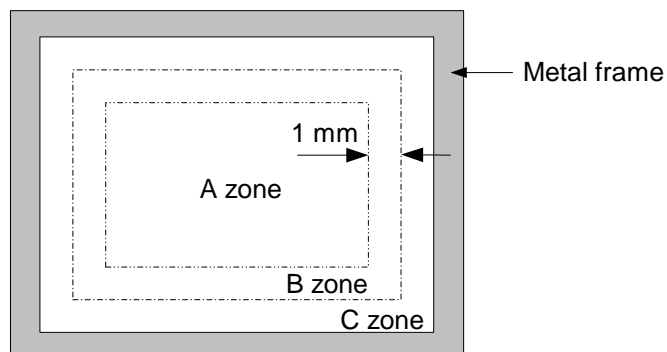

Fig. 11.2

## 12.2 LCD APPEARANCE SPECIFICATION

The specification as below is defined as the amount of unexpected phenomenon or material in different zones of LCD panel. The definitions of length, width and average diameter using in the table are shown in Fig. 12.3 and Fig. 12.4.

Item	Criteria				Applied zone
Scratches	Length L(mm)	Width W(mm)	Maximum number	Minimum space	A,B
	$L \leq 2.0$	$W \leq 0.03$	Ignored	-	
	$L \leq 2.0$	$0.03 < W \leq 0.05$	4	-	
	$L \leq 2.0$	$0.05 < W$	none	-	
Dent	Serious one is not allowed				A
Wrinkles in polarizer	Serious one is not allowed				A
Bubbles on polarizer	Average diameter D(mm)		Maximum number Acceptable		A
	$D \leq 0.3$		2		
	$0.3 < D$		none		
1) Stains 2) Foreign Materials 3) Dark Spot	Filamentous (Line shape)				A,B
	Length L(mm)	Width W(mm)	Maximum number Acceptable		
	$L < 2.0$	$W \leq 0.05$	4		
	$L \leq 1.0$	$0.05 < W \leq 0.1$	2		
	Round (Dot shape)				A,B
	Average diameter D(mm)		Maximum number acceptable	Minimum Space	
	$D < 0.15$		6	-	
	$0.15 < D \leq 0.2$		4	-	
	$0.2 < D$		none	-	
	In total		Filamentous + Round=9		
	Those wiped out easily are acceptable				A,B
	Dot-Defect (Note 1)	Sparkle mode	Type	Maximum number	
1 dot			4		
2 dots			2(sets)		
Black mode		In total	4		
		1 dot	4		
		2 dots	2(sets)		
Sparkle mode & Black mode		In total	4		
		2 dots	2(sets)		
In total			6		

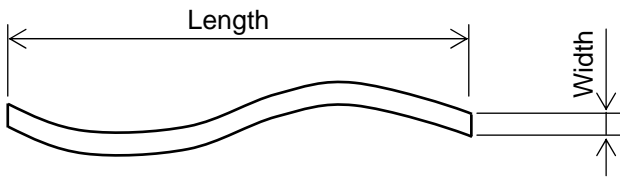

Fig 12.3

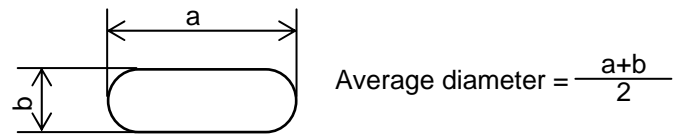
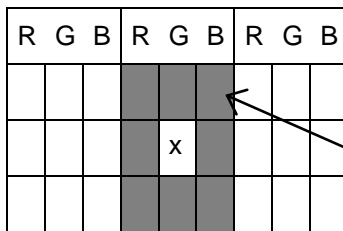

Fig 12.4

Note 1: The definitions of dot defect are as below:

- The defect area of the dot must be bigger than half of a dot.
- For bright dot-defect, showing black pattern, the dot's brightness must be over 30% brighter than others.
- For dark dot-defect, showing white pattern, the dot's brightness must be under 70% darker than others.
- The definition of 1-dot-defect is the defect-dot, which is isolated and no adjacent defect-dot.
- The definition of adjacent dot is shown as Fig. 12.5.



The dots colored in gray are adjacent to defect - dot "X".

Fig 12.5

### 12.3 TOUCH PANEL APPEARANCE SPECIFICATION

The specification as below is defined by the amount of unexpected material in different zones of touch panel.

Item	Criteria			Applied zone
Scratches	Length L(mm)	Width W(mm)	Maximum number acceptable	A,B
	-	$W < 0.05$	Ignored	
	$10 < L$	$0.05 \leq W < 0.1$	none	
	-	$0.1 \leq W$	none	
Foreign Materials	Filamentous (Line shape)			A
	Length L(mm)	Width W(mm)	Maximum number acceptable	
	-	$W < 0.05$	Ignored	
	$L > 3$	$0.05 \leq W \leq 0.1$	None	
	-	$W \geq 0.1$	Round	
	Round (Dot shape)			A
	Average diameter D(mm)		Maximum number acceptable	
	$D > 0.25$		Not allowed	
	$0.25 < D \leq 0.35$		3 pcs max.	
	$0.35 < D$		Ignored	

The limitation of glass flaw occurred on touch panel is defined in the table as below.

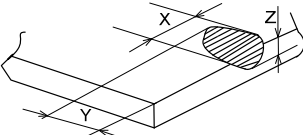
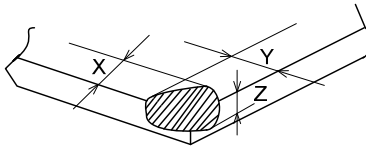
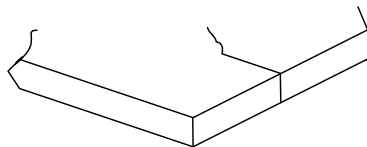
Item	Specifications	
Edge flaw		$X \leq 5.0 \text{ mm}$ $Y \leq 3.0 \text{ mm}$ $Z \leq \text{Thickness}$
Corner flaw		$X \leq 3.0 \text{ mm}$ $Y \leq 3.0 \text{ mm}$ $Z \leq \text{Thickness}$
Progressive flaw		Not allowed

## 13. PRECAUTIONS

### 13.1 PRECAUTIONS of MOUNTING

1) Please refer to Fig. 13.1 for housing the display with touch panel into applications. The Fig. 13.1 shows some points as below:

- The cushion needs to be designed between housing and touch panel in order to avoid unexpected pressure to cause any wrong reactions, and the cushion should be located in the insulated area.
- The housing should not cover the active area of touch panel as the figure shown.

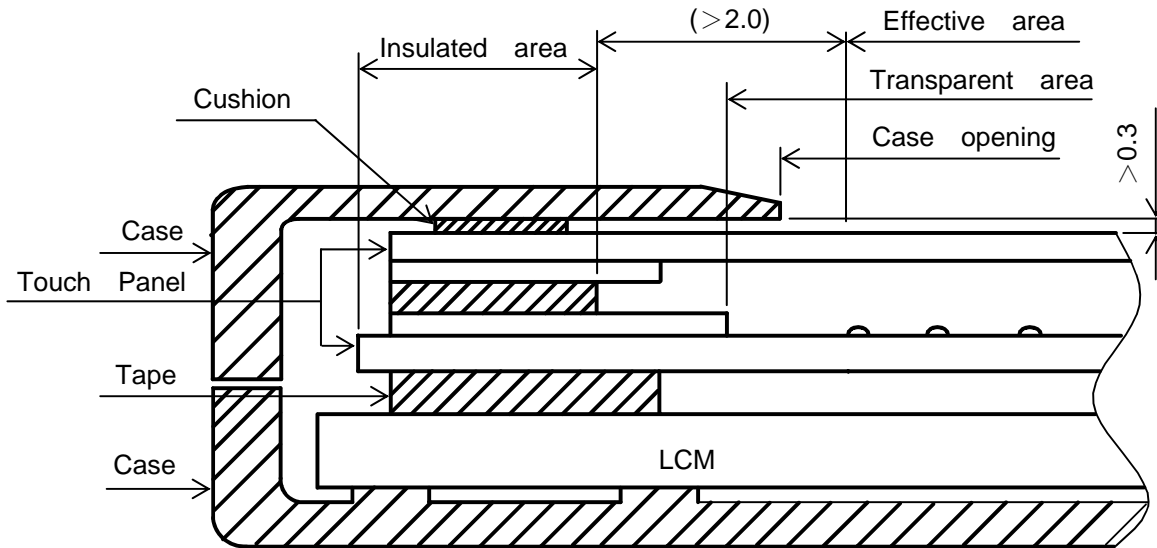

Fig 13.1

### 13.2 PRECAUTIONS of ESD

- 1) Before handling the display, please ensure your body has been connected to ground to avoid any damages by ESD. Also, do not touch display's interface directly when assembling.
- 2) Please remove the protection film very slowly before turning on the display to avoid generating ESD.

### 13.3 PRECAUTIONS of HANDLING

- 1) In order to keep the appearance of display in good condition, please do not rub any surfaces of the displays by sharp tools harder than 3H, especially touch panel, metal frame and polarizer.
- 2) Please do not pile the displays in order to avoid any scars leaving on the display. In order to avoid any injuries, please pay more attention for the edges of glasses and metal frame, and wear finger cots to protect yourself and the display before working on it.
- 3) Touching the display area or the terminal pins with bare hand is prohibited. This is because it will stain the display area and cause poor insulation between terminal pins, and might affect display's electrical characteristics furthermore.
- 4) Do not use any harmful chemicals such as acetone, toluene, and isopropyl alcohol to clean display's surfaces.
- 5) Please use soft cloth or absorbent cotton with ethanol to clean the display by gently wiping. Moreover, when wiping the display, please wipe it by horizontal or vertical direction instead of circling to prevent leaving scars on the display's surface, especially polarizer.



- 6) Please wipe any unknown liquids immediately such as saliva, water or dew on the display to avoid color fading or any permanently damages.
- 7) Maximum pressure to the surface of the display must be less than  $1,96 \times 10^4$  Pa. If the area of adding pressure is less than  $1 \text{ cm}^2$ , the maximum pressure must be less than 1.96N.

### 13.4 PRECAUTIONS OF OPERATING

- 1) Please input signals and voltages to the displays according to the values defined in the section of electrical characteristics to obtain the best performance. Any voltages over than absolute maximum rating will cause permanent damages to this display. Also, any timing of the signals out of this specification would cause unexpected performance.
- 2) When the display is operating at significant low temperature, the response time will be slower than it at  $25 \text{ C}^\circ$ . In high temperature, the color will be slightly dark and blue compared to original pattern. However, these are temperature-related phenomenon of LCD and it will not cause permanent damages to the display when used within the operating temperature.
- 3) The use of screen saver or sleep mode is recommended when static images are likely for long periods of time. This is to avoid the possibility of image sticking.
- 4) Spike noise can cause malfunction of the circuit. The recommended limitation of spike noise is no bigger than  $\pm 100 \text{ mV}$ .

### 13.5 PRECAUTIONS of STORAGE

If the displays are going to be stored for years, please be aware the following notices.

- 1) Please store the displays in a dark room to avoid any damages from sunlight and other sources of UV light.
- 2) The recommended long term storage temperature is between  $10 \text{ C}^\circ \sim 35 \text{ C}^\circ$  and 55%~75% humidity to avoid causing bubbles between polarizer and LCD glasses, and polarizer peeling from LCD glasses.
- 3) It would be better to keep the displays in the container, which is shipped from KOE, and do not unpack it.
- 4) Please do not stick any labels on the display surface for a long time, especially on the polarizer.

# 14. DESIGNATION OF LOT MARK

## 14.1 LOT MARK

Lot mark is consisted of 4 digits for production lot and 6 digits for production control.



Year	Mark
2012	2
2013	3
2014	4
2015	5
2016	6

Month	Jan.	Feb.	Mar.	Apr.	May	Jun.
Mark	01	02	03	04	05	06
Month	Jul.	Aug.	Sep.	Oct.	Nov.	Dec.
Mark	07	08	09	10	11	12

Week (Day In Calendar)	Figure In Lot Mark
01~07	1
08~14	2
15~21	3
22~28	4
29~31	5

## 14.2 SERIAL No.

Serial No. is consisted of 6 digits number (000001~999999).

## 14.3 REVISION (REV.) CONTROL

Rev. is the column for manufacturing convenience A-Z except I and O maybe written on this column.

REV. No	ITEM	NOTE
A	-	-
B	Film of TP change	PCN0852

## 14.4 LOCATION OF LABEL : On the PCB

