



# SPECIFICATION

---



**TX09D30VM1CDA**

**3.5" - QVGA - RGB**

Version:

Date: 03.01.2023

Note: This specification is subject to change without prior notice



FOR MESSRS : \_\_\_\_\_

DATE : Jan. 3<sup>rd</sup>, 2023

## CUSTOMER'S ACCEPTANCE SPECIFICATIONS

### TX09D30VM1CDA

#### Contents

No.	ITEM	SHEET No.	PAGE
1	COVER	7B64PS 2701-TX09D30VM1CDA-8	1-1/1
2	RECORD OF REVISION	7B64PS 2702-TX09D30VM1CDA-8	2-1/3~3/3
3	GENERAL DATA	7B64PS 2703-TX09D30VM1CDA-8	3-1/1
4	ABSOLUTE MAXIMUM RATINGS	7B64PS 2704-TX09D30VM1CDA-8	4-1/1
5	ELECTRICAL CHARACTERISTICS	7B64PS 2705-TX09D30VM1CDA-8	5-1/1
6	OPTICAL CHARACTERISTICS	7B64PS 2706-TX09D30VM1CDA-8	6-1/2~2/2
7	BLOCK DIAGRAM	7B64PS 2707-TX09D30VM1CDA-8	7-1/1
8	RELIABILITY TESTS	7B64PS 2708-TX09D30VM1CDA-8	8-1/1
9	LCD INTERFACE	7B64PS 2709-TX09D30VM1CDA-8	9-1/6~6/6
10	OUTLINE DIMENSIONS	7B64PS 2710-TX09D30VM1CDA-8	10-1/1
11	APPEARANCE STANDARD	7B64PS 2711-TX09D30VM1CDA-8	11-1/3~3/3
12	PRECAUTIONS	7B64PS 2712-TX09D30VM1CDA-8	12-1/2~2/2
13	DESIGNATION OF LOT MARK	7B64PS 2713-TX09D30VM1CDA-8	13-1/1



ACCEPTED BY : \_\_\_\_\_

PROPOSED BY : Oblack Tsai

## 2. RECORD OF REVISION

DATE	SHEET No.	SUMMARY														
Sep.16,'09	7B64PS 2703 – TX09D30VM1CDA-2 Page 3 – 1/1	<p>3.1 DISPLAY FEATURES</p> <p>Changed</p> <table border="1"> <tr> <td>Power Consumption</td> <td>75 mW for LCD; 260 mW for backlight</td> </tr> <tr> <td colspan="2" style="text-align: center;">↓</td> </tr> <tr> <td>Power Consumption</td> <td>0.4W</td> </tr> </table>	Power Consumption	75 mW for LCD; 260 mW for backlight	↓		Power Consumption	0.4W								
	Power Consumption	75 mW for LCD; 260 mW for backlight														
	↓															
Power Consumption	0.4W															
7B64PS 2705 – TX09D30VM1CDA-2 Page 5 – 1/1	<p>5.1 LCD CHARACTERISTICS</p> <p>Changed</p> <table border="1"> <tr> <th>Item</th> <th>Typ.</th> <th>Max.</th> </tr> <tr> <td>Power Supply Current</td> <td>100</td> <td>-</td> </tr> <tr> <td colspan="3" style="text-align: center;">↓</td> </tr> <tr> <th>Item</th> <th>Typ.</th> <th>Max.</th> </tr> <tr> <td>Power Supply Current</td> <td>120</td> <td>145</td> </tr> </table>	Item	Typ.	Max.	Power Supply Current	100	-	↓			Item	Typ.	Max.	Power Supply Current	120	145
Item	Typ.	Max.														
Power Supply Current	100	-														
↓																
Item	Typ.	Max.														
Power Supply Current	120	145														
7B64PS 2708 – TX09D30VM1CDA-2 Page 8 – 1/1	<p>8. RELIABILITY TESTS</p> <p>Changed</p> <table border="1"> <thead> <tr> <th>Test Item</th> <th colspan="2">Condition</th> </tr> </thead> <tbody> <tr> <td rowspan="2">ESD</td> <td>                     1) Non-Operating                      2) Tip: 200 pF, 250 Ω                      3) Air discharge for glass: ±8KV                      4) Contact discharge for metal frame: ±8KV                      5) Contact discharge for LCD interface: ±100V                 </td> <td>                     1) Glass: 9 points                      2) Metal frame: 8 points                      3) Connector: all pins                 </td> </tr> <tr> <td colspan="2" style="text-align: center;">↓</td> </tr> <tr> <th>Test Item</th> <th colspan="2">Condition</th> </tr> <tr> <td rowspan="2">ESD</td> <td>                     1) Operating                      2) Tip: 200 pF, 250 Ω                      3) Air discharge for glass: ±8KV                      4) Contact discharge for metal frame: ±8KV                 </td> <td>                     1) Glass: 9 points                      2) Metal frame: 8 points                 </td> </tr> </tbody> </table> <p>Revised</p> <p>Note 3: Under the condition of high temperature &amp; humidity, if the temperature is higher than 40°C, the humidity needs to be reduced as Fig. 7.1 shown.</p> <p style="text-align: center;">↓</p> <p>Note 3: All pins of LCD interface(CN1) have been tested by ±100V contact discharge of ESD under non-operating condition.</p>	Test Item	Condition		ESD	1) Non-Operating 2) Tip: 200 pF, 250 Ω 3) Air discharge for glass: ±8KV 4) Contact discharge for metal frame: ±8KV 5) Contact discharge for LCD interface: ±100V	1) Glass: 9 points 2) Metal frame: 8 points 3) Connector: all pins	↓		Test Item	Condition		ESD	1) Operating 2) Tip: 200 pF, 250 Ω 3) Air discharge for glass: ±8KV 4) Contact discharge for metal frame: ±8KV	1) Glass: 9 points 2) Metal frame: 8 points	
Test Item	Condition															
ESD	1) Non-Operating 2) Tip: 200 pF, 250 Ω 3) Air discharge for glass: ±8KV 4) Contact discharge for metal frame: ±8KV 5) Contact discharge for LCD interface: ±100V	1) Glass: 9 points 2) Metal frame: 8 points 3) Connector: all pins														
	↓															
Test Item	Condition															
ESD	1) Operating 2) Tip: 200 pF, 250 Ω 3) Air discharge for glass: ±8KV 4) Contact discharge for metal frame: ±8KV	1) Glass: 9 points 2) Metal frame: 8 points														
	Jan.14,'11	7B64PS 2703 – TX09D30VM1CDA-3 Page 13 – 1/1	<p>13.3 REVISION (REV.) CONTROL</p> <p>Added</p> <table border="1"> <thead> <tr> <th>REV No.</th> <th>ITEM</th> <th>NOTE</th> </tr> </thead> <tbody> <tr> <td>A</td> <td>-</td> <td>-</td> </tr> <tr> <td>C</td> <td>Th connectors on FPC Changed</td> <td>-</td> </tr> </tbody> </table>	REV No.	ITEM	NOTE	A	-	-	C	Th connectors on FPC Changed	-				
REV No.	ITEM	NOTE														
A	-	-														
C	Th connectors on FPC Changed	-														

DATE	SHEET No.	SUMMARY																	
May 01,'12	All pages	Company name changed: KAOHSIUNG HITACHI ELECTRONICS CO.,LTD. ↓ KAOHSIUNG OPTO-ELECTRONICS INC.																	
	7B64PS 2704 – TX09D30VM1CDA-4 Page 4 - 1/1	4. ABSOLUTE MAXIMUM RATINGS Revised : Note2																	
	7B64PS 2708 – TX09D30VM1CDA-4 Page 8 - 1/1	8. RELIABILITY TESTS Added : Note4																	
Apr. 11,'13	7B64PS 2704 – TX09D30VM1CDA-5 Page 4 - 1/1	4. ABSOLUTE MAXIMUM RATINGS <table border="1" data-bbox="587 607 1198 689"> <thead> <tr> <th>Item</th> <th>Min.</th> <th>Max.</th> <th>Unit</th> </tr> </thead> <tbody> <tr> <td>Operating Temperature</td> <td>-20</td> <td>70</td> <td>°C</td> </tr> </tbody> </table> ↓ <table border="1" data-bbox="587 725 1198 808"> <thead> <tr> <th>Item</th> <th>Min.</th> <th>Max.</th> <th>Unit</th> </tr> </thead> <tbody> <tr> <td>Operating Temperature</td> <td>-30</td> <td>80</td> <td>°C</td> </tr> </tbody> </table> Revised : Note 2.	Item	Min.	Max.	Unit	Operating Temperature	-20	70	°C	Item	Min.	Max.	Unit	Operating Temperature	-30	80	°C	
	Item	Min.	Max.	Unit															
Operating Temperature	-20	70	°C																
Item	Min.	Max.	Unit																
Operating Temperature	-30	80	°C																
7B64PS 2708 – TX09D30VM1CDA-5 Page 8 - 1/1	8. RELIABILITY TESTS <table border="1" data-bbox="587 902 1198 1099"> <thead> <tr> <th>Test Item</th> <th colspan="2">Condition</th> </tr> </thead> <tbody> <tr> <td>High Temperature</td> <td>1) Operating 2) 70°C</td> <td>240 hrs</td> </tr> <tr> <td>Low Temperature</td> <td>1) Operating 2) -20°C</td> <td>240 hrs</td> </tr> </tbody> </table> ↓ <table border="1" data-bbox="587 1135 1198 1332"> <thead> <tr> <th>Test Item</th> <th colspan="2">Condition</th> </tr> </thead> <tbody> <tr> <td>High Temperature</td> <td>1) Operating 2) 80°C</td> <td>240 hrs</td> </tr> <tr> <td>Low Temperature</td> <td>1) Operating 2) -30°C</td> <td>240 hrs</td> </tr> </tbody> </table> Revised : Note 1. Revised : Fig 8.1	Test Item	Condition		High Temperature	1) Operating 2) 70°C	240 hrs	Low Temperature	1) Operating 2) -20°C	240 hrs	Test Item	Condition		High Temperature	1) Operating 2) 80°C	240 hrs	Low Temperature	1) Operating 2) -30°C	240 hrs
Test Item	Condition																		
High Temperature	1) Operating 2) 70°C	240 hrs																	
Low Temperature	1) Operating 2) -20°C	240 hrs																	
Test Item	Condition																		
High Temperature	1) Operating 2) 80°C	240 hrs																	
Low Temperature	1) Operating 2) -30°C	240 hrs																	
Aug.30,'16	7B64PS 2703 – TX09D30VM1CDA-6 Page 3 – 1/1	3.1 DISPLAY FEATURES Revised : Power Consumption 0.4W → 0.33W																	
	7B64PS 2704 – TX09D30VM1CDA-6 Page 4 – 1/1	4. ABSOLUTE MAXIMUM RATINGS Revised : LED Backlight Forward Current IF=35mA → 30mA Revised : Note 3 、 Note 4 、 Fig 4.1																	
	7B64PS 2705 – TX09D30VM1CDA-6 Page 5 – 1/1	5.1 LCD CHARACTERISTICS Revised : <table border="1" data-bbox="708 1727 1238 1816"> <thead> <tr> <th>Item</th> <th>Typ.</th> <th>Max.</th> </tr> </thead> <tbody> <tr> <td>Power Supply Current</td> <td>120</td> <td>145</td> </tr> </tbody> </table> ↓ <table border="1" data-bbox="708 1852 1238 1942"> <thead> <tr> <th>Item</th> <th>Typ.</th> <th>Max.</th> </tr> </thead> <tbody> <tr> <td>Power Supply Current</td> <td>100</td> <td>120</td> </tr> </tbody> </table>	Item	Typ.	Max.	Power Supply Current	120	145	Item	Typ.	Max.	Power Supply Current	100	120					
Item	Typ.	Max.																	
Power Supply Current	120	145																	
Item	Typ.	Max.																	
Power Supply Current	100	120																	
JDI Taiwan Inc. Kaohsiung Branch		SHEET NO.	7B64PS 2702-TX09D30VM1CDA-8	PAGE	2-2/3														

DATE	SHEET No.	SUMMARY																																								
Aug.30,'16	7B64PS 2705 – TX09D30VM1CDA-6 Page 5 – 1/1	5.2 BACKLIGHT CHARACTERISTICS Revised : <table border="1" data-bbox="619 232 1444 454"> <thead> <tr> <th>Item</th> <th>Condition</th> <th>Typ.</th> <th>Max.</th> </tr> </thead> <tbody> <tr> <td>LED Input Voltage</td> <td>IF=12mA</td> <td>3.2</td> <td>3.5</td> </tr> <tr> <td>LED Forward Current</td> <td>Backlight Unit</td> <td>12</td> <td>-</td> </tr> <tr> <td>LED Reverse Current</td> <td>VR=5V</td> <td>50</td> <td>-</td> </tr> <tr> <td>LED Life Time</td> <td>IF=12mA</td> <td>40</td> <td>-</td> </tr> </tbody> </table> <p style="text-align: center;">↓</p> <table border="1" data-bbox="619 495 1444 712"> <thead> <tr> <th>Item</th> <th>Condition</th> <th>Typ.</th> <th>Max.</th> </tr> </thead> <tbody> <tr> <td>LED Input Voltage</td> <td>IF=10mA</td> <td>3.2</td> <td>3.5</td> </tr> <tr> <td>LED Forward Current</td> <td>Backlight Unit</td> <td>10</td> <td>-</td> </tr> <tr> <td>LED Reverse Current</td> <td>VR=5V</td> <td>-</td> <td>10</td> </tr> <tr> <td>LED Life Time</td> <td>IF=10mA</td> <td>40</td> <td>-</td> </tr> </tbody> </table>	Item	Condition	Typ.	Max.	LED Input Voltage	IF=12mA	3.2	3.5	LED Forward Current	Backlight Unit	12	-	LED Reverse Current	VR=5V	50	-	LED Life Time	IF=12mA	40	-	Item	Condition	Typ.	Max.	LED Input Voltage	IF=10mA	3.2	3.5	LED Forward Current	Backlight Unit	10	-	LED Reverse Current	VR=5V	-	10	LED Life Time	IF=10mA	40	-
Item	Condition	Typ.	Max.																																							
LED Input Voltage	IF=12mA	3.2	3.5																																							
LED Forward Current	Backlight Unit	12	-																																							
LED Reverse Current	VR=5V	50	-																																							
LED Life Time	IF=12mA	40	-																																							
Item	Condition	Typ.	Max.																																							
LED Input Voltage	IF=10mA	3.2	3.5																																							
LED Forward Current	Backlight Unit	10	-																																							
LED Reverse Current	VR=5V	-	10																																							
LED Life Time	IF=10mA	40	-																																							
	7B64PS 2706 – TX09D30VM1CDA-6 Page 6 – 1/2	6. OPTICAL CHARACTERISTICS Revised : Condition ILED=12mA → 10mA																																								
Jun.16,'21	7B64PS 2713 – TX09D30VM1CDA-7 Page 13 – 1/1	13.3 REVISION (REV.) CONTROL Added <table border="1" data-bbox="632 909 1431 987"> <thead> <tr> <th>REV No.</th> <th>ITEM</th> <th>NOTE</th> </tr> </thead> <tbody> <tr> <td>D</td> <td>LCD Source Changed</td> <td>PCN 1028</td> </tr> </tbody> </table>	REV No.	ITEM	NOTE	D	LCD Source Changed	PCN 1028																																		
REV No.	ITEM	NOTE																																								
D	LCD Source Changed	PCN 1028																																								
Jan.03,'23	7B64PS 2701 – TX09D30VM1CDA-8 Page 1 – 1/1 7B64PS 2713 – TX09D30VM1CDA-8 Page 13 – 1/1 All page	Company logo changed : <div style="display: flex; align-items: center; justify-content: center;"> <div style="text-align: center;">               Kaohsiung Opto-Electronics Inc.           </div> <div style="margin: 0 20px;">→</div> <div style="text-align: center;">               Japan Display Inc.           </div> </div> Company name changed: From “KAOHSIUNG OPTO-ELECTRONICS INC.” to “JDI Taiwan Inc. Kaohsiung Branch”																																								

### 3. GENERAL DATA

#### 3.1 DISPLAY FEATURES

This module is a 3.5" QVGA TFT with 3 by 4 format, which is composed of amorphous silicon. Each sub-pixel (dot) on the LCD is vertical stripe type arranged as R (red), G (green), B (blue) color sequentially. The bounding technology, COG (chip on glass), and LED backlight design have been applied on this display RoHS compliant.

Part Name	TX09D30VM1CDA
Module Dimensions	64.0(W) mm x 86.0(H) mm x 6.7(D) mm typ.
LCD Active Area	53.64(W) mm x 71.52(H) mm
Dot Pitch	0.0745(W) mm x 3(R, G, B)(W) x 0.2235(H) mm
Resolution	240 x 3(RGB)(W) x 320(H) dots
Color Pixel Arrangement	R, G, B Vertical stripe
LCD Type	Transmissive Color TFT; Normally White
Display Type	Active Matrix
Number of Colors	262k Colors
Backlight	Light Emitting Diode (LED) x 6
Weight	40 g (typ.)
Interface	C-MOS; 18-bit RGB; 40 pins
Power Supply Voltage	3.3V (Including LCD ,Timing Controller and Backlight)
Power Consumption	0.33W
Viewing Direction	6 O'clock (No inversion of gray level scale and less change in brightness)

## 4. ABSOLUTE MAXIMUM RATINGS

Item	Symbol	Min.	Max.	Unit	Remarks	
Supply Voltage	VCC	-0.3	3.6	V	-	
Input Voltage of Logic	VI	0	VCC	V	Note 1	
Operating Temperature	Top	-30	80	°C	Note 2	
Storage Temperature	Tst	-30	85	°C	Note 2	
LED Backlight	Forward Current	IF	-	30	mA	Note 3
	Pulse Forward Current	IFP	-	100	mA	Note 4
	Reverse Voltage	VR	-	5	V	LED unit

Note 1: The rating is defined for the signal voltages of the interface such as DTMG, DCLK and RGB data bus.

Note 2: The maximum rating is defined as above based on the panel surface temperature, which might be different from ambient temperature after assembling the panel into the application. Moreover, some temperature-related phenomenon as below needed to be noticed:

- Background color, contrast and response time would be different from 25°C.
- Operating under high temperature will shorten LED lifetime.

Note 3: Fig. 4.1 shows the maximum rating of forward current based on different temperature for LED unit. Moreover, the backlight unit of this display has been set at 10 mA per LED, which is located at the allowable area when display is operated within Top, -20~70°C.

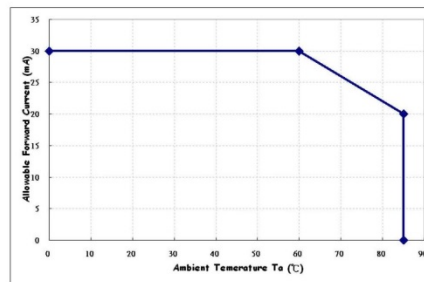
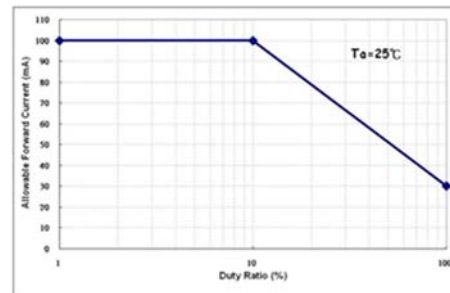
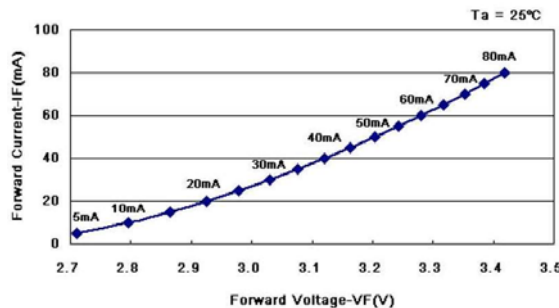

Fig. 4.1

Note 4: Fig. 4.2 and 4.3 show the LED characteristics of the relationship between VF v.s. IFP and IFP v.s. Duty Ratio, which is related to dimming control of LED backlight. Either adjusting DC voltage or applying Pulse Width Modulation (PWM) signal is the method to have this functionality.



## 5. ELECTRICAL CHARACTERISTICS

### 5.1 LCD CHARACTERISTICS

Ta=25°C, VSS=0V

Item	Symbol	Condition	Min.	Typ.	Max.	Unit	Remarks
Power Supply Voltage	VCC	-	3.0	3.3	3.6	V	-
Input Voltage of Logic	VI	"H" level	0.8VCC	-	VCC	V	Note 1
		"L" level	VSS	-	0.2VCC		
Power Supply Current	IDD	VCC-VSS=3.0V	-	100	120	mA	Note 2
Vsync Frequency	FV	-	-	60	68	Hz	-
Hsync Frequency	FH	-	18.57	20.77	22.73	KHz	-
DCLK Frequency	FCLK	-	5.0	5.6	6.5	MHz	-

Note 1: The rating is defined for the signal voltages of the interface such as DCLK and RGB data bus.

Note 2: All black on the screen is the check pattern to measure IDD, which is based on FV=60 Hz.

### 5.2 BACKLIGHT CHARACTERISTICS

Ta=25°C

Item	Symbol	Condition	Min.	Typ.	Max.	Unit	Remarks
LED Input Voltage	VF	IF=10mA	-	3.2	3.5	V	LED/Part
LED Forward Current	IF	Backlight Unit	-	10	-	mA	LED/Part
LED Reverse Current	IR	VR=5V	-	-	10	μA	LED/Part
LED Current Control	PWM	(VIN=3.3V)	1	-	30	KHz	(Note1)
LED Life Time	-	IF=10mA	-	40	-	Khr	

Note 1: PWM's frequency, 1KHz ~ 30KHz, is recommended.



# 6. OPTICAL CHARACTERISTICS

The optical characteristics are measured based on the conditions as below:

- Supplying the signals and voltages defined in the section of electrical characteristics.
- The backlight unit needs to be turned on after 30 minutes.
- The ambient temperature is 25°C.
- In the dark room around 500~1000 lx, the equipment has been set for the measurements as shown in Fig 6.1.

2 2/3

Ta=25°C, FV=60Hz, VCC=3.3V

Item	Symbol	Condition	Min.	Typ.			
Brightness of white	B	$\phi=0^\circ, \theta=0^\circ$ ILED= 10 mA	240	320	-	cd/m <sup>2</sup>	Note 1
Brightness uniformity	-		70	-	-	%	Note 2
Contrast Ratio	CR		180	300	-	-	Note 3
Response time	RISE(Ton)	$\phi=0^\circ, \theta=0$	-	15	-	ms	Note 4
	FALL(Toff)		-	15	-		
NTSC Ratio	-	$\phi=0^\circ, \theta=0$	-	50	-	%	-
Viewing Angle	$\theta=X$	$\phi=0^\circ, CR \geq 10$	60	70	-	Degree	Note 5
	$\theta=X'$	$\phi=180^\circ, CR \geq 10$	60	70	-		
	$\theta=Y$	$\phi=90^\circ, CR \geq 10$	70	80	-		
	$\theta=Y'$	$\phi=270^\circ, CR \geq 10$	50	60	-		
Color chromaticity	Red	X	0.54	0.59	0.64	-	Note 6
		Y	0.29	0.34	0.39		
	Green	X	0.31	0.36	0.41		
		Y	0.51	0.56	0.61		
	Blue	X	0.10	0.15	0.20		
		Y	0.08	0.13	0.18		
	White	X	0.28	0.33	0.38		
		Y	0.29	0.34	0.39		

Note 1: The brightness is measured from the center point of the panel, P5 in Fig. 6.2, for the typical value.

Note 2: The brightness uniformity is calculated by the equation as below:

$$\text{Brightness uniformity} = \frac{\text{Min. Brightness}}{\text{Max. Brightness}} \times 100\%$$

, which is based on the brightness values of the 9 points measured by BM-5 as shown in Fig. 6.2.

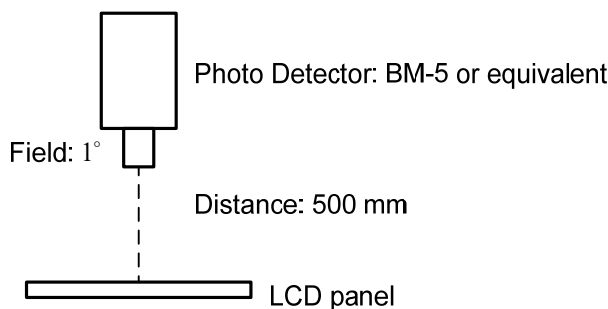

Fig. 6.1

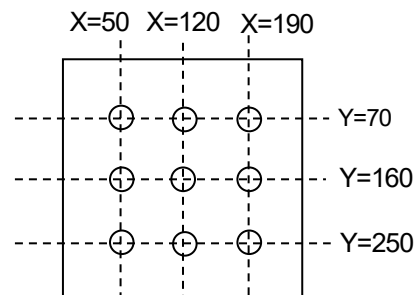

Fig. 6.2

Note 3: The Contrast Ratio is measured from the center point of the panel, P5, and defined as the following equation:

$$CR = \frac{\text{Brightness of White}}{\text{Brightness of Black}}$$

Note 4: The definition of response time is shown in Fig. 6.3. Rising time is the period from 90% brightness down to 10% brightness when the data is from white turning to black. Oppositely, Falling time is the period from 10% brightness rising to 90% brightness.

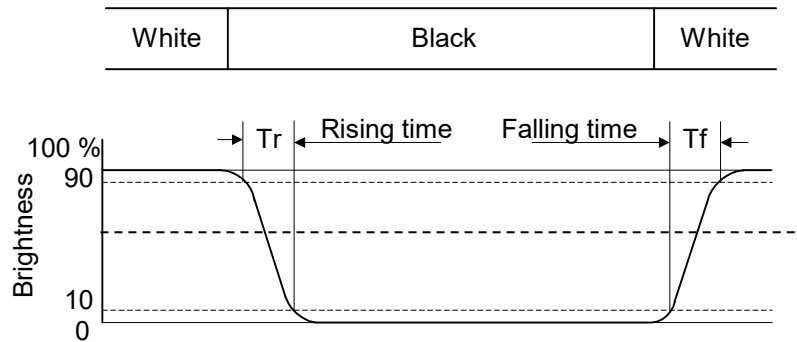

Fig . 6.3

Note 5: The definition of viewing angle is shown in Fig. 6.4. Angle  $\phi$  is used to represent viewing directions, for instance,  $\phi = 270^\circ$  means 6 o'clock, and  $\phi = 0^\circ$  means 3 o'clock. Moreover, angle  $\theta$  is used to represent viewing angles from axis Z toward plane XY.

The viewing direction of this display is 6 o'clock, which means that a photograph with gray scale would not be reversed in color and the brightness change would be less from this direction. However, the contrast peak would be located at 12 o'clock.

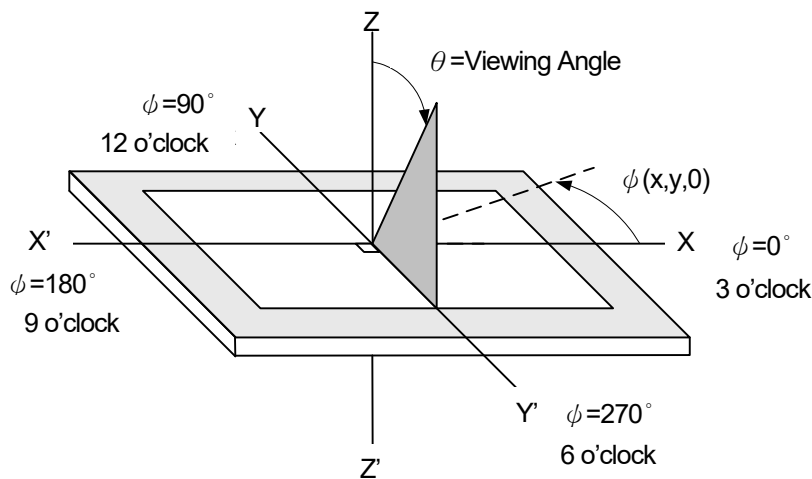
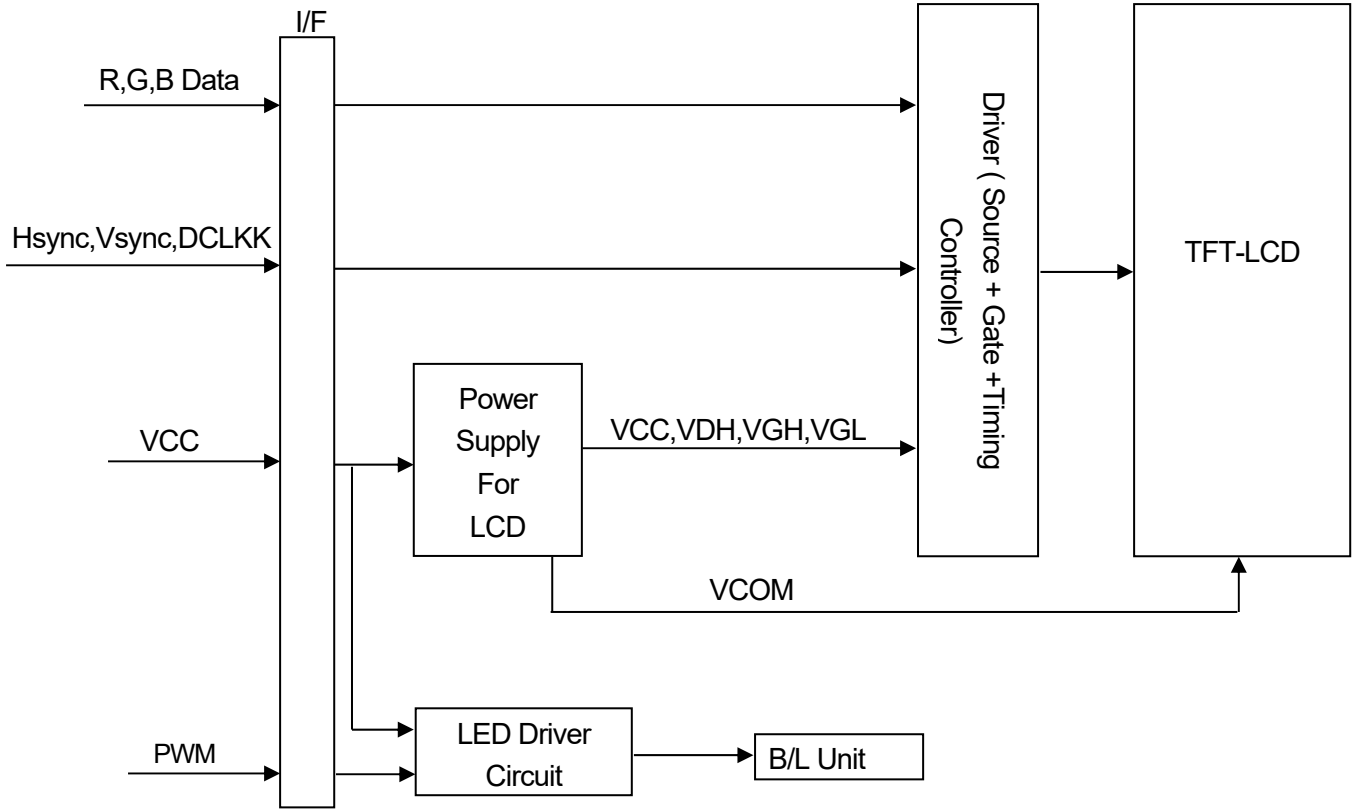

Fig. 6.4

Note 6: The color chromaticity is measured from the center point of the panel, P5, as shown in Fig. 6.2.

# 7. BLOCK DIAGRAM



## 8. RELIABILITY TESTS

Test Item	Condition	
High Temperature	1) Operating 2) 80 °C	240 hrs
Low Temperature	1) Operating 2) -30 °C	240 hrs
High Temperature	1) Storage 2) 80 °C	240 hrs
Low Temperature	1) Storage 2) -30 °C	240 hrs
Heat Cycle	1) Operating 2) -20 °C ~70 °C 3) 3hrs~1hr~3hrs	240 hrs
Thermal Shock	1) Non-Operating 2) -35 °C ↔ 85 °C 3) 0.5 hr ↔ 0.5 hr	240 hrs
High Temperature & Humidity	1) Operating 2) 40 °C & 85%RH 3) Without condensation (Note4)	240 hrs
Vibration	1) Non-Operating 2) 20~200 Hz 3) 3G 4) X, Y, and Z directions	1 hr for each direction
Mechanical Shock	1) Non-Operating 2) 10 ms 3) 50G 4) ±X, ±Y and ±Z directions	Once for each direction
ESD	1) Operating 2) Tip: 200 pF, 250 Ω 3) Air discharge for glass: ±8KV 4) Contact discharge for metal frame: ±8KV	1) Glass: 9 points 2) Metal frame: 8 points (Note3)

Note 1: There is no display functionality failure occurred after the reliability tests.

Note 2: The display is not guaranteed for use in corrosive gas environments.

Note 3: All pins of LCD interface(CN1) have been tested by ±100V contact discharge of ESD under non-operating condition.

Note 4: Under the condition of high temperature & humidity, if the temperature is higher than 40°C, the humidity needs to be reduced as Fig. 8.1 shown.

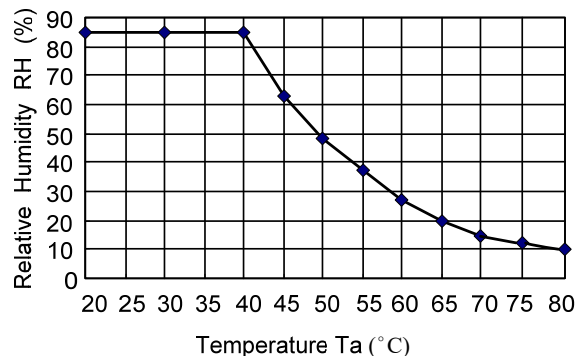

Fig. 8.1

## 9. LCD INTERFACE

### 9.1 INTERFACE PIN CONNECTIONS

The connector of display interface is FA5S040HP1R3000 made by JAE (Thickness:  $0.3 \pm 0.05\text{mm}$ ; Pitch:  $0.5 \pm 0.05\text{mm}$ ) and more details of the connector are shown in the section of outline dimension.

Pin assignment of LCD interface is as below:

Pin No.	Signal	Function	Pin No.	Signal	Function
1	VCC	Power Supply for Logic	21	G4	Green Data
2	VCC		22	G3	
3	VCC		23	VSS	GND
4	DCLK	Dot Clock	24	G2	Green Data
5	GND	GND	25	G1	
6	HSYNC	Horizontal Sync Pulse	26	G0	
7	NC	No Connection	27	VSS	GND
8	GND	GND	28	B5	Blue Data
9	VSS	GND	29	B4	
10	VSYNC	Vertical Sync Pulse	30	B3	
11	VSS	GND	31	VSS	GND
12	R5	RED DATA	32	B2	Blue Data
13	R4		33	B1	
14	R3		34	B0	
15	VSS	GND	35	NC	No connection
16	R2	RED DATA	36	PWM	LED Current Control
17	R1		37	NC	No connection
18	R0		38	NC	No connection
19	VSS	GND	39	NC	No connection
20	G5	Green Data	40	NC	No connection

## 9.2 TIMING CHART

	SYMBOL	MIN.	TYP.	MAX.	UNIT
Back porch for Horizontal	HBP	12	12	12	Clock
Front porch for Horizontal	HFP	15	18 Note1	21	Clock
Back porch for Vertical	VBP	8	8	8	HSYNC (Note 3)
Front porch for Vertical	VFP	17	20 Note2	22	HSYNC

Note 1 : (DOTCLK total) - ((Valid data period for Horizontal) + (HBP))

Note 2 : (HSYNC total) - ((Active Area period) + VBP)

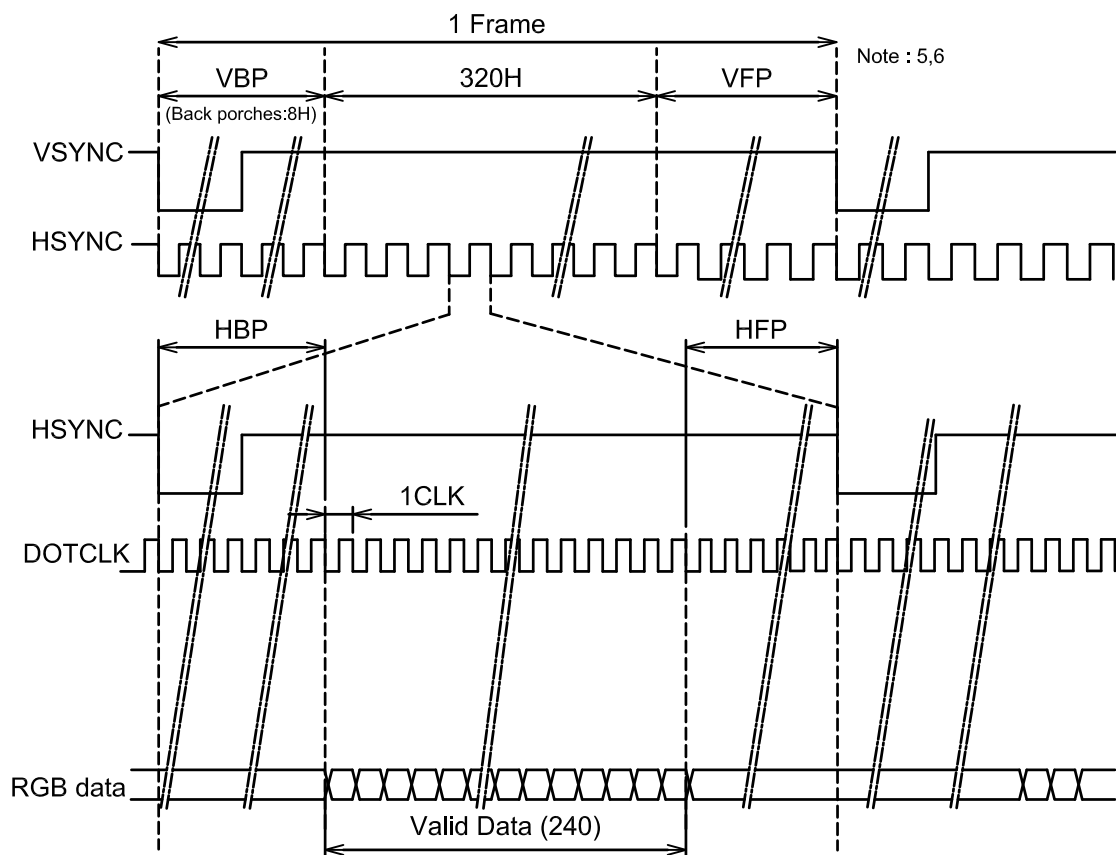

Note 3 : Note about VSYNC timing setting

Check the timing chart of VSYNC and HSYNC , If timing setting is not set as Fig1, it must be set as Fig2 .

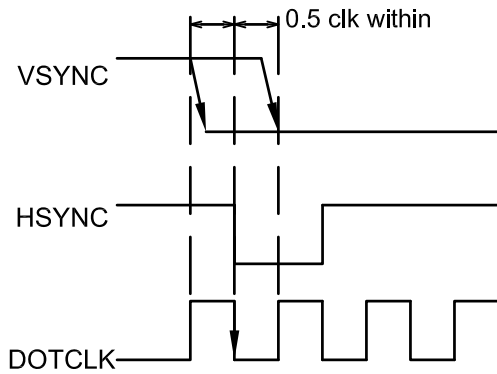

Fig1. VSYNC timing

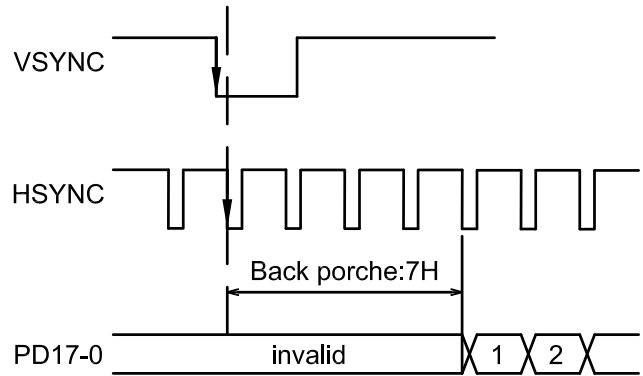

Fig2. Vertical back porch regulation

Note 4 : The DOTCLK signal must be supplied consecutively.

Note 5 : Front and back porches (VBP , VFP) must be set before and after the display operation period.

Note 6 : The front porch period continues until the next input of VSYNC signal.

### 9.3 INTERFACE TIMING SPECIFICATIONS

ITEM	SYMBOL	MIN.	TYP.	MAX.	UNIT	REMARKS
DOTCLK cycle time	tCYCD	100	-	-	ns	1 trans
		50	-	-		3 trans
DOTCLK low level pulse width	PWDL	20	-	-	ns	-
DOTCLK high level pulse width	PWDH	20	-	-	ns	-
VSYNC setup time	tVSYNCS	0	-	1	clock	-
HSYNC setup time	tHSYNCS	0	-	1	clock	-
RGB data setup time	TPDS	20	-	-	ns	-
RGB data hold time	TPDH	20	-	-	ns	-
DOTCLK/VSYNC/HSYNC rising edge, falling edge times	trgbr / trgbf	-	-	20	ns	-

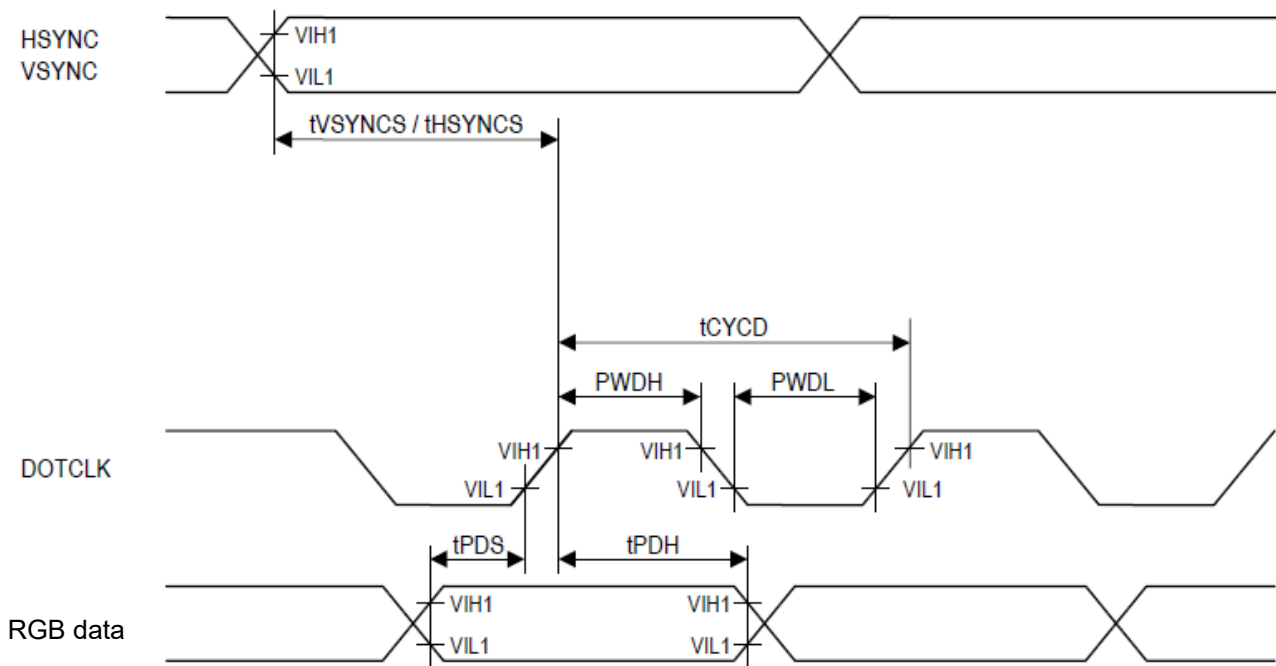

**Fig3. RGB Interface timing**



## 9.4 POWER SEQUENCE

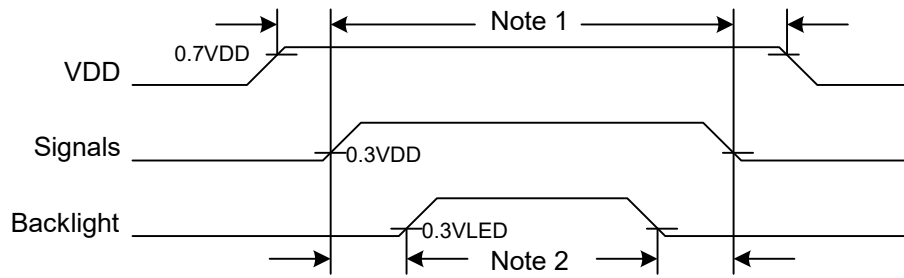

Fig. 9.4 Power Sequence Timing

Note 1: In order to avoid any damages, VDD has to be applied before all other signals. The opposite is true for power off where VDD has to be remained on until all other signals have been switch off. The recommended time period is 0.5 second.

Note 2: In order to avoid showing uncompleted patterns in transient state. It is recommended that switching the backlight on is delayed for 0.5 second after the signals have been applied. The opposite is true for power off where the backlight has to be switched off 0.5 second before the signals are removed.

### 9.5 DATA INPUT for DISPLAY COLOR

	COLOR & Gray Scale	Data Signal																	
		R5	R4	R3	R2	R1	R0	G5	G4	G3	G2	G1	G0	B5	B4	B3	B2	B1	B0
Basic Color	Black	0	0	0	0	0	0	0	0	0	0	0	0	0	0	0	0	0	0
	Red (0)	1	1	1	1	1	1	0	0	0	0	0	0	0	0	0	0	0	0
	Green (0)	0	0	0	0	0	0	1	1	1	1	1	1	0	0	0	0	0	0
	Blue (0)	0	0	0	0	0	0	0	0	0	0	0	0	1	1	1	1	1	1
	Cyan	0	0	0	0	0	0	1	1	1	1	1	1	1	1	1	1	1	1
	Magenta	1	1	1	1	1	1	0	0	0	0	0	0	1	1	1	1	1	1
	Yellow	1	1	1	1	1	1	1	1	1	1	1	1	0	0	0	0	0	0
	White	1	1	1	1	1	1	1	1	1	1	1	1	1	1	1	1	1	1
Red	Black	0	0	0	0	0	0	0	0	0	0	0	0	0	0	0	0	0	0
	Red (62)	0	0	0	0	0	1	0	0	0	0	0	0	0	0	0	0	0	0
	Red (61)	0	0	0	0	1	0	0	0	0	0	0	0	0	0	0	0	0	0
	:	:	:	:	:	:	:	:	:	:	:	:	:	:	:	:	:	:	:
	:	:	:	:	:	:	:	:	:	:	:	:	:	:	:	:	:	:	:
	Red (1)	1	1	1	1	1	0	0	0	0	0	0	0	0	0	0	0	0	0
Red (0)	1	1	1	1	1	1	0	0	0	0	0	0	0	0	0	0	0	0	
Green	Black	0	0	0	0	0	0	0	0	0	0	0	0	0	0	0	0	0	0
	Green (62)	0	0	0	0	0	0	0	0	0	0	0	1	0	0	0	0	0	0
	Green (61)	0	0	0	0	0	0	0	0	0	0	0	1	0	0	0	0	0	0
	:	:	:	:	:	:	:	:	:	:	:	:	:	:	:	:	:	:	:
	:	:	:	:	:	:	:	:	:	:	:	:	:	:	:	:	:	:	:
	Green (1)	0	0	0	0	0	0	1	1	1	1	1	1	0	0	0	0	0	0
Green (0)	0	0	0	0	0	0	1	1	1	1	1	1	0	0	0	0	0	0	
Blue	Black	0	0	0	0	0	0	0	0	0	0	0	0	0	0	0	0	0	0
	Blue (62)	0	0	0	0	0	0	0	0	0	0	0	0	0	0	0	0	0	1
	Blue (61)	0	0	0	0	0	0	0	0	0	0	0	0	0	0	0	0	1	0
	:	:	:	:	:	:	:	:	:	:	:	:	:	:	:	:	:	:	:
	:	:	:	:	:	:	:	:	:	:	:	:	:	:	:	:	:	:	:
	Blue (1)	0	0	0	0	0	0	0	0	0	0	0	0	1	1	1	1	1	0
Blue (0)	0	0	0	0	0	0	0	0	0	0	0	0	1	1	1	1	1	1	

# 10. OUTLINE DIMENSIONS

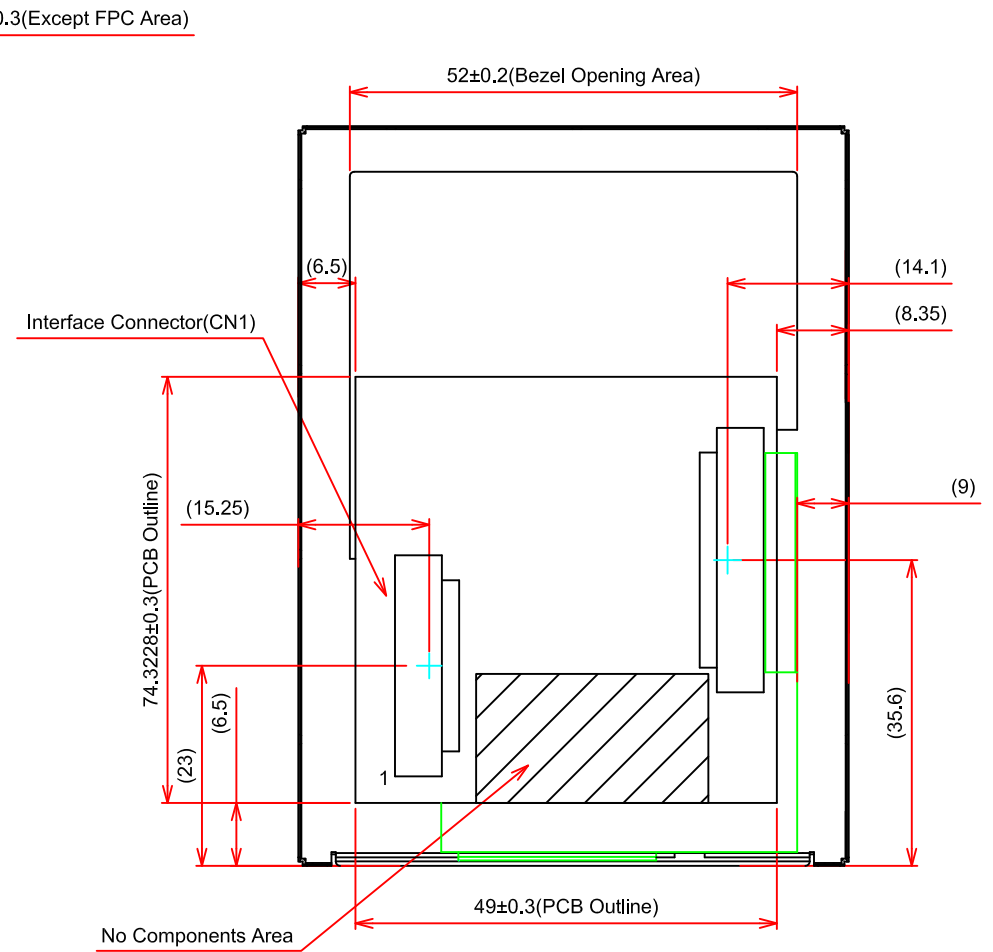
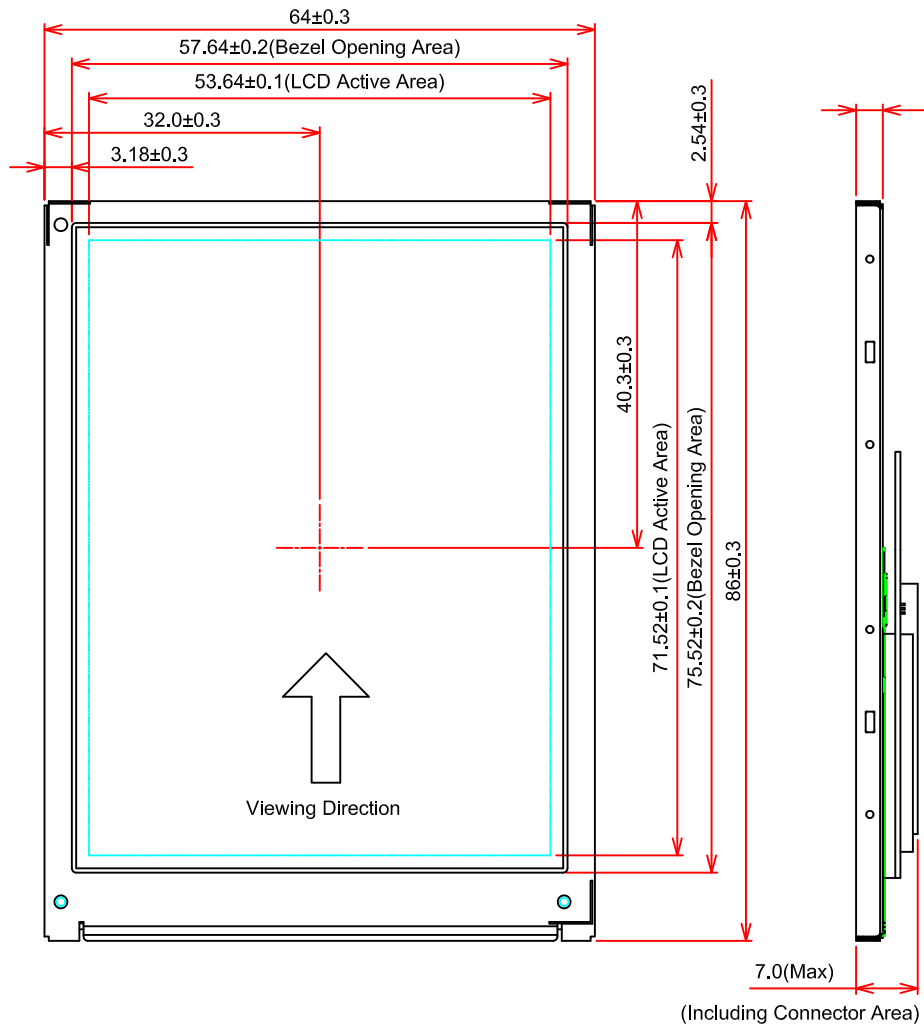

Scale : NTS  
Unit : mm

# 11. APPEARANCE STANDARD

The appearance inspection is performed in a dark room around 500~1000 lx based on the conditions as below:

- The distance between inspector's eyes and display is 30 cm.
- The viewing zone is defined with angle  $\theta$  shown in Fig. 11.1 The inspection should be performed within  $45^\circ$  when display is shut down. The inspection should be performed within  $5^\circ$  when display is power on.

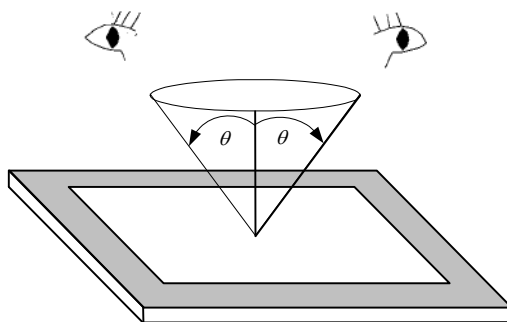

Fig. 11.1

## 11.1 THE DEFINITION OF LCD ZONE

LCD panel is divided into 3 areas as shown in Fig.11.2 for appearance specification in next section. A zone is the LCD active area (dot area); B zone is the area, which extended 1 mm out from LCD active area; C zone is the area between B zone and metal frame.

In terms of housing design, B zone is the recommended window area customers' housing should be located in.

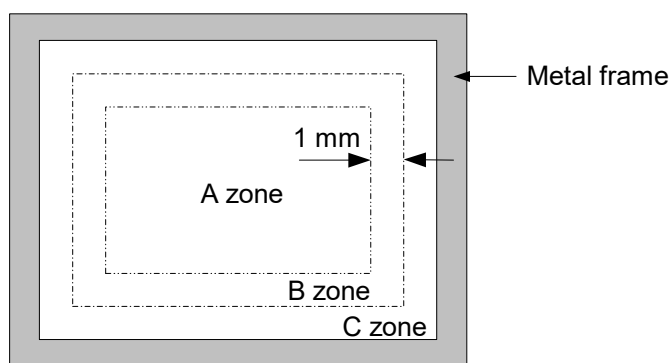

Fig. 11.2

## 11.2 LCD APPEARANCE SPECIFICATION

The specification as below is defined as the amount of unexpected phenomenon or material in different zones of LCD panel. The definitions of length, width and average diameter using in the table are shown in Fig. 11.3 and Fig. 11.4.

No.	ITEM	CRITERIA			APPLIED ZONE	
L C D	Scratches	Length L(mm)	Width W(mm)	Maximum number acceptable	A,B	
		$L \leq 2.0$	$W \leq 0.03$	ignored		
		$L \leq 2.0$	$0.03 < W \leq 0.05$	4		
		$L > 2.0$	$0.05 < W$	none		
	Dent	Serious one is not allowed			A	
	Wrinkles in polarizer	Serious one is not allowed			A	
	Bubbles	Average diameter D(mm)	Maximum number acceptable		A	
		$D \leq 0.3$	2			
		$0.3 < D$	none			
	Stains Foreign Materials	Filamentous (Line shape)			A,B	
		Length L(mm)	Width W(mm)	Maximum number acceptable		
		$L < 2.0$	$W \leq 0.05$	4		
	Dark spot	Round(Dot shape)			A,B	
		Average diameter D(mm)	Maximum number acceptable			
		$D \leq 0.15$	6			
		$0.15 < D \leq 0.2$	4			
		$0.2 < D$	none			
		The total number	Filamentous + Round=9			
		Those wiped out easily are acceptable				
		Dot Defect				Maximum number acceptable
	Sparkle mode		1 dot	4		
			2 dots	2(sets)		
			Total	4		
	Black mode		1 dot	4		
2 dots			2(sets)			
Total			4			
Sparkle mode & Black mode	2 dots		2(sets)			
Total	6					

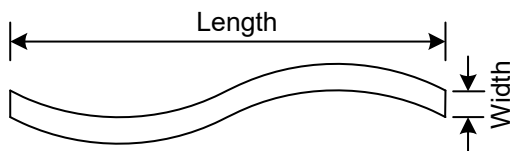
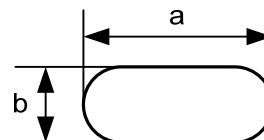

Fig. 11.3



$$\text{Average diameter} = \frac{a + b}{2}$$

Fig. 11.4

Note 1: The definitions of dot defect are as below:

- The defect area of the dot must be bigger than half of a dot.
- For bright dot-defect, showing black pattern, the dot's brightness must be over 30% brighter than others.
- For dark dot-defect, showing white pattern, the dot's brightness must be under 70% darker than others.
- The definition of 1-dot-defect is the defect-dot, which is isolated and no adjacent defect-dot.
- The definition of adjacent dot is shown as Fig. 11.5.

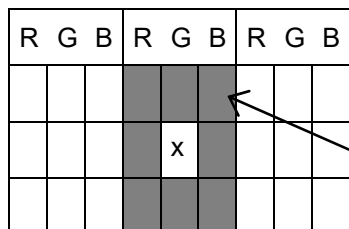

The dots colored in gray are adjacent to defect - dot "X".

Fig 11.5

## 12. PRECAUTIONS

### 12.1 PRECAUTIONS of ESD

- 1) Before handling the display, please ensure your body has been connected to ground to avoid any damages by ESD. Also, do not touch display's interface directly when assembling.
- 2) Please remove the protection film very slowly before turning on the display to avoid generating ESD.

### 12.2 PRECAUTIONS of HANDLING

- 1) In order to keep the appearance of display in good condition, please do not rub any surfaces of the displays by using sharp tools harder than 3H, especially touch panel, metal frame and polarizer.
- 2) Please do not stack the displays as this may damage the surface. In order to avoid any injuries, please avoid touching the edge of the glass or metal frame and wore gloves during handling.
- 3) Touching the polarizer or terminal pins with bare hand should be avoided to prevent staining and poor electrical contact.
- 4) Do not use any harmful chemicals such as acetone, toluene, and isopropyl alcohol to clean display's surfaces.
- 5) Please use soft cloth or absorbent cotton with ethanol to clean the display by gently wiping. Moreover, when wiping the display, please wipe it by horizontal or vertical direction instead of circling to prevent leaving scars on the display's surface, especially polarizer.
- 6) Please wipe any unknown liquids immediately such as saliva, water or dew on the display to avoid color fading or any permanent damages.
- 7) Maximum pressure to the surface of the display must be less than  $1.96 \times 10^4$  Pa. If the area of applied pressure is less than  $1 \text{ cm}^2$ , the maximum pressure must be less than 1.96N.

### 12.3 PRECAUTIONS OF OPERATING

- 1) Please input signals and voltages to the displays according to the values defined in the section of electrical characteristics to obtain the best performance. Any voltages over than absolute maximum rating will cause permanent damages to this display. Also, any timing of the signals out of this specification would cause unexpected performance.
- 2) When the display is operating at significant low temperature, the response time will be slower than it at  $25^\circ\text{C}$ . In high temperature, the color will be slightly dark and blue compared to original pattern. However, these are temperature-related phenomenon of LCD and it will not cause permanent damages to the display when used within the operating temperature.
- 3) The use of screen saver or sleep mode is recommended when static images are likely for long periods of time. This is to avoid the possibility of image sticking.
- 4) Spike noise can cause malfunction of the circuit. The recommended limitation of spike noise is no bigger than  $\pm 100 \text{ mV}$ .

## 12.4 PRECAUTIONS of STORAGE

If the displays are going to be stored for years, please be aware the following notices.

- 1) Please store the displays in a dark room to avoid any damages from sunlight and other sources of UV light.
- 2) The recommended long term storage temperature is between  $10^{\circ}\text{C}$ ~ $35^{\circ}\text{C}$  and 55%~75% humidity to avoid causing bubbles between polarizer and LCD glasses, and polarizer peeling from LCD glasses.
- 3) It would be better to keep the displays in the container, which is shipped from JDI, and do not unpack it.
- 4) Please do not stick any labels on the display surface for a long time, especially on the polarizer.



# 13. DESIGNATION OF LOT MARK

## 13.1 LOT MARK

Lot mark is consisted of 4 digits for production lot and 6 digits for production control.



Year	Mark
2013	3
2014	4
2015	5
2016	6
2017	7

Month	Jan.	Feb.	Mar.	Apr.	May	Jun.
Mark	01	02	03	04	05	06
Month	Jul.	Aug.	Sep.	Oct.	Nov.	Dec.
Mark	07	08	09	10	11	12

Week (Day In Calendar)	Figure In Lot Mark
01~07	1
08~14	2
15~21	3
22~28	4
29~31	5

## 13.2 SERIAL No.

Serial No. is consisted of 6 digits number (000001~999999).

## 13.3 REVISION (REV.) CONTROL

Rev. is the column for manufacturing convenience A-Z except I and O maybe written on this column.

REV.No	ITEM	NOTE
A	-	-
C	The connectors on FPC changed.	-
D	LCD Source Changed	PCN 1028

## 13.4 LOCATION OF LABEL : On the PCB

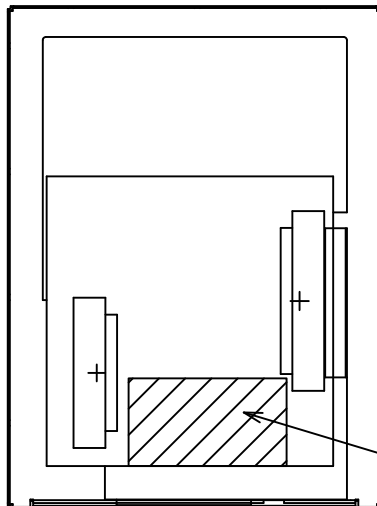

Label example :

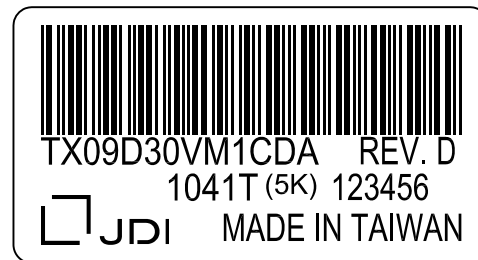

Label

# DATA MODUL



ALL TECHNOLOGIES. ALL COMPETENCIES. ONE SPECIALIST.



DATA MODUL AG  
Landsberger Straße 322  
DE-80687 Munich  
Phone: +49-89-56017-0

DATA MODUL WEIKERSHEIM GMBH  
Lindenstraße 8  
DE-97990 Weikersheim  
Phone: +49-7934-101-0



More information and worldwide locations can be found at

[www.data-modul.com](http://www.data-modul.com)