



SPECIFICATION

KOE
JDI Group

TX18D203VM2BPA

7" TFT - WVGA - C-MOS

Version: TX18D203VM2BPA-2

Date: 30.08.2016

Note: This specification is subject to change without prior notice

KOE

JDI Group

Kaohsiung Opto-Electronics Inc.

FOR MESSRS : _____

DATE : Aug. 30th, 2016

CUSTOMER'S ACCEPTANCE SPECIFICATIONS

TX18D203VM2BPA

Contents

No.	ITEM	SHEET No.	PAGE
1	COVER	7B64PS 2701-TX18D203VM2BPA-2	1-1/1
2	RECORD OF REVISION	7B64PS 2702-TX18D203VM2BPA-2	2-1/1
3	GENERAL DATA	7B64PS 2703-TX18D203VM2BPA-2	3-1/1
4	ABSOLUTE MAXIMUM RATINGS	7B64PS 2704-TX18D203VM2BPA-2	4-1/1
5	ELECTRICAL CHARACTERISTICS	7B64PS 2705-TX18D203VM2BPA-2	5-1/1
6	OPTICAL CHARACTERISTICS	7B64PS 2706-TX18D203VM2BPA-2	6-1/2~2/2
7	BLOCK DIAGRAM	7B64PS 2707-TX18D203VM2BPA-2	7-1/1
8	RELIABILITY TESTS	7B64PS 2708-TX18D203VM2BPA-2	8-1/1
9	LCD INTERFACE	7B64PS 2709-TX18D203VM2BPA-2	9-1/7~7/7
10	OUTLINE DIMENSIONS	7B64PS 2710-TX18D203VM2BPA-2	10-1/2~2/2
11	TOUCH PANEL	7B64PS 2711-TX18D203VM2BPA-2	11-1/2~2/2
12	APPEARANCE STANDARD	7B64PS 2712-TX18D203VM2BPA-2	12-1/4~4/4
13	PRECAUTIONS	7B64PS 2713-TX18D203VM2BPA-2	13-1/2~2/2
14	DESIGNATION OF LOT MARK	7B64PS 2714-TX18D203VM2BPA-2	14-1/1

ACCEPTED BY : _____

PROPOSED BY: *Oblack Tsai*

2. RECORD OF REVISION

DATE	SHEET No.	SUMMARY
Aug.30,'16	7B64PS 2711 – TX18D203VM2BPA-2 PAGE 11-1/2	11.2 ELECTRICAL CHARACTERISTICS Revised : X1-X2 : 400~1200Ω → 300~1400Ω Y1-Y2 : 190~660Ω → 100~900Ω

3. GENERAL DATA

3.1 DISPLAY FEATURES

This module is a 7.0" WVGA of 16:9 format amorphous silicon TFT. The pixel format is vertical stripe and sub pixels are arranged as R (red), G (green), B (blue) sequentially. This display is RoHS compliant, COG (chip on glass) technology and LED backlight are applied on this display.

Part Name	TX18D203VM2BPA
Module Dimensions	165.0(W) mm x 113.0(H) mm x 9.1 (D) mm
LCD Active Area	152.4(W) mm x 91.44(H) mm
Pixel Pitch	0.1905(W) mm x 0.1905 (H) mm
Resolution	800 x 3(RGB)(W) x 480(H) dots
Color Pixel Arrangement	R, G, B Vertical stripe
LCD Type	Transmissive Color TFT; Normally White
Display Type	Active Matrix
Number of Colors	262k Colors (6-bit RGB)
Backlight	Light Emitting Diode(LED)
Weight	214 g
Interface	CMOS ; 40 pins
Power Supply Voltage	3.3V for LCD; 12V for backlight
Power Consumption	0.76W for LCD; 3.84W for backlight
Viewing Direction	12 O'clock (without image inversion and least brightness change) 6 O'clock (contrast peak located at)
Touch Panel	Resistive type; Film on Glass; 4-wire type; Anti-glare surface

4. ABSOLUTE MAXIMUM RATINGS

Item	Symbol	Min.	Max.	Unit	Remarks
Supply Voltage	V_{DD}	0	7.0	V	-
Input Voltage of Logic	V_I	-0.3	$V_{DD}+0.3$	V	Note 1
Operating Temperature	T_{op}	-20	70	°C	Note 2
Storage Temperature	T_{st}	-30	80	°C	Note 2

Note 1: The rating is defined for the signal voltages of the interface such as DE, Hsync, Vsync, CLK and RGB data bus.

Note 2: The maximum rating is defined as above based on the chamber temperature, which might be different from ambient temperature after assembling the panel into the application. Moreover, some temperature-related phenomenon as below needed to be noticed:

- Background color, contrast and response time would be different in temperatures other than 25°C.
- Operating under high temperature will shorten LED lifetime.

5. ELECTRICAL CHARACTERISTICS

5.1 LCD CHARACTERISTICS

$T_a = 25\text{ }^\circ\text{C}$, $V_{SS} = 0\text{V}$

Item	Symbol	Condition	Min.	Typ.	Max.	Unit	Remarks
Power Supply Voltage	V_{DD}	-	3.0	3.3	3.6	V	-
Input Voltage of Logic	V_I	"H" level	$0.8V_{DD}$	-	V_{DD}	V	Note 1
		"L" level	V_{SS}	-	$0.2V_{DD}$		
Power Supply Current	I_{DD}	-	-	230	-	mA	Note 2
Frame Frequency	f_{Frame}	-	-	60	65	Hz	-
CLK Frequency	f_{CLK}	-	29	32.32	36.15	MHz	

Note 1: The rating is defined for the signal voltages of the interface such as DE, Hsync, Vsync, CLK and RGB data bus.

Note 2: An all black check pattern is used when measuring I_{DD} , f_{Frame} is set to 60 Hz.

Note 3: 1.0A fuse is applied in the module for I_{DD} . For display activation and protection purpose, power supply is recommended larger than 2.5A to start the display and break fuse once any short circuit occurred.

5.2 BACKLIGHT CHARACTERISTICS

$T_a = 25^\circ C$

Item	Symbol	Condition	Min.	Typ.	Max.	Unit	Remarks
LED Input Voltage	V_{LED}	Backlight Unit	11.5	12.0	12.5	V	Note 1
LED Forward Current	I_{LED}	0V;0%duty	290	320	350	mA	Note 2
		3.3VDC;100%duty	10	20	30		
LED Lifetime	-	$I_{LED}=320mA$	-	40K	-	hrs	Note 3

Note 1: As Fig. 5.1 shown, LED current is constant, 320 mA, controlled by the LED driver when applying 12V.

Note 2: Dimming function can be obtained by applying DC voltage or PWM signal from the display interface CN1. The recommended PWM signal is 1K ~ 10K Hz with 3.3V amplitude.

Note 3: The estimated lifetime is specified as the time to reduce 50% brightness by applying 320 mA at $25^\circ C$.

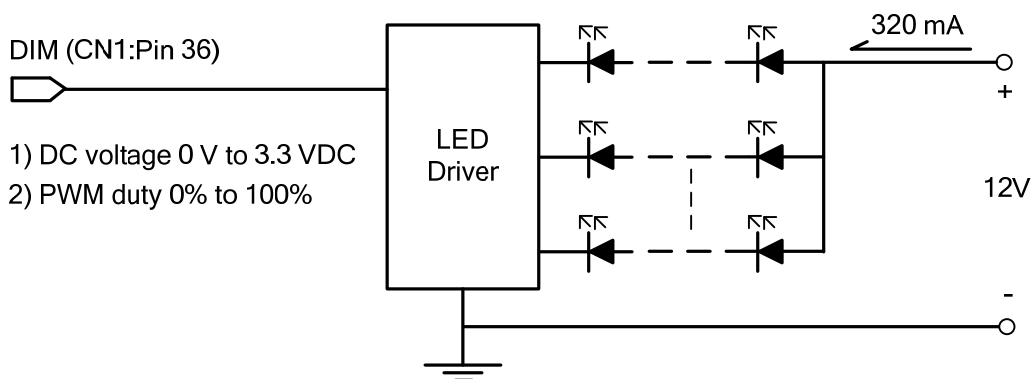

Fig 5.1

6. OPTICAL CHARACTERISTICS

The optical characteristics are measured based on the conditions as below:

- Supplying the signals and voltages defined in the section of electrical characteristics.
- The backlight unit needs to be turned on for 30 minutes.
- The ambient temperature is 25 °C .
- In the dark room less than 100 lx, the equipment has been set for the measurements as shown in Fig 6.1.

$$T_a = 25\text{ }^\circ\text{C}, f_{Frame} = 60\text{ Hz}, V_{DD} = 3.3\text{V}$$

Item	Symbol	Condition	Min.	Typ.	Max.	Unit	Remarks	
Brightness of White	-	$I_{LED} = 320\text{mA}$ $\phi = 0^\circ, \theta = 0^\circ$	960	1200	-	cd/m ²	Note 1	
Brightness Uniformity	-		70	-	-	%	Note 2	
Contrast Ratio	CR		300	600	-	-	Note 3	
Response Time	Tr + Tf	$\phi = 0^\circ, \theta = 0^\circ$	-	20	-	ms	Note 4	
NTSC Ratio	-	$\phi = 0^\circ, \theta = 0^\circ$	-	45	-	%	-	
Viewing Angle	θ_x	$\phi = 0^\circ, CR \geq 10$	-	70	-	Degree	Note 5	
	$\theta_{x'}$	$\phi = 180^\circ, CR \geq 10$	-	70	-			
	θ_y	$\phi = 90^\circ, CR \geq 10$	-	65	-			
	$\theta_{y'}$	$\phi = 270^\circ, CR \geq 10$	-	55	-			
Color Chromaticity	Red	X	$\phi = 0^\circ, \theta = 0^\circ$	0.52	0.57	0.62	-	Note 6
		Y		0.30	0.35	0.40		
	Green	X		0.30	0.35	0.40		
		Y		0.52	0.57	0.62		
	Blue	X		0.10	0.15	0.20		
		Y		0.07	0.12	0.17		
	White	X		0.25	0.30	0.35		
		Y		0.28	0.33	0.38		

Note 1: The brightness is measured from the center point of the panel, P5 in Fig. 6.2, for the typical value.

Note 2: The brightness uniformity is calculated by the equation as below:

$$\text{Brightness uniformity} = \frac{\text{Min. Brightness}}{\text{Max. Brightness}} \times 100\%$$

which is based on the brightness values of the 9 points in active area measured by BM-5 as shown in Fig. 6.2.

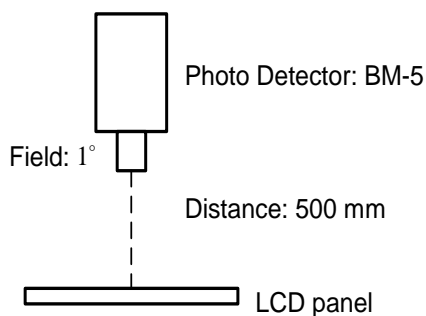

Fig 6.1

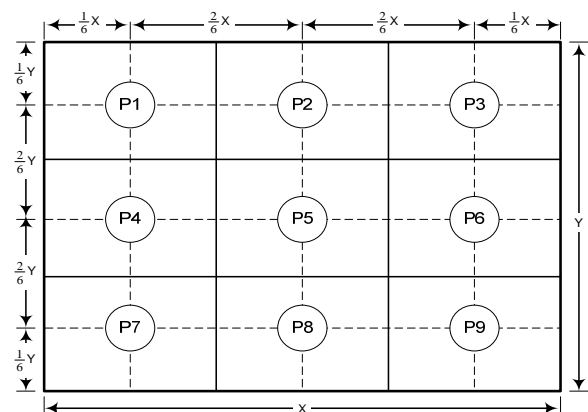

Fig 6.2

Note 3: The Contrast ratio is measured from the center point of the panel, P5, and defined as the following equation:

$$CR = \frac{\text{Brightness of White}}{\text{Brightness of Black}}$$

Note 4: The definition of response time is shown in Fig. 6.3. The rising time is the period from 90% brightness to 10% brightness when the data is from white to black. Oppositely, Falling time is the period from 10% brightness rising to 90% brightness.

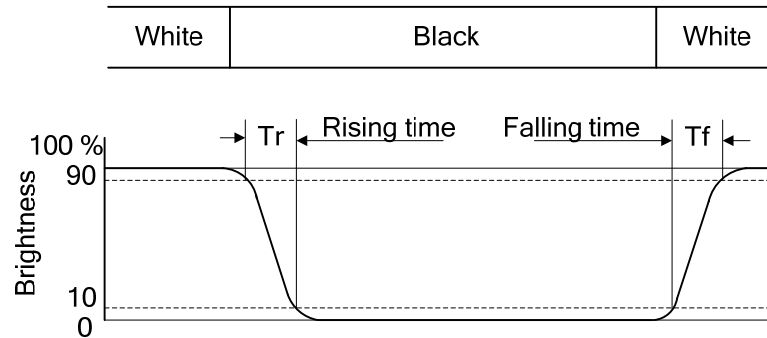

Fig 6.3

Note 5: The definition of viewing angle is shown in Fig. 6.4. Angle ϕ is used to represent viewing directions, for instance, $\phi = 270^\circ$ means 6 o'clock, and $\phi = 0^\circ$ means 3 o'clock. Moreover, angle θ is used to represent viewing angles from axis Z toward plane XY.

The viewing direction of this display is 12 o'clock, which means that a photograph with gray scale would not be reversed in color and the brightness change would be less from this direction. However, the best contrast peak would be located at 6 o'clock.

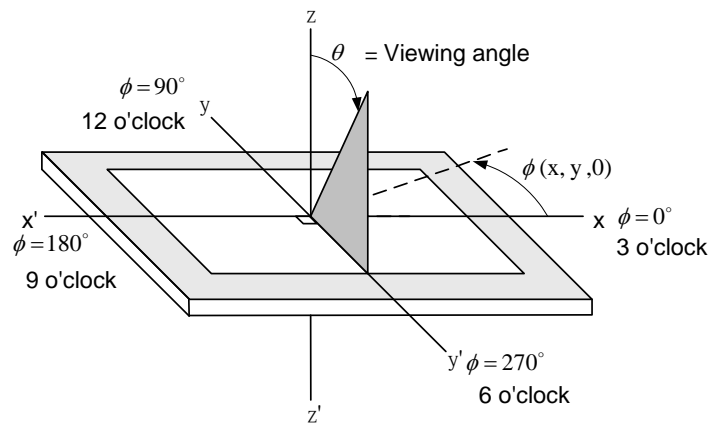
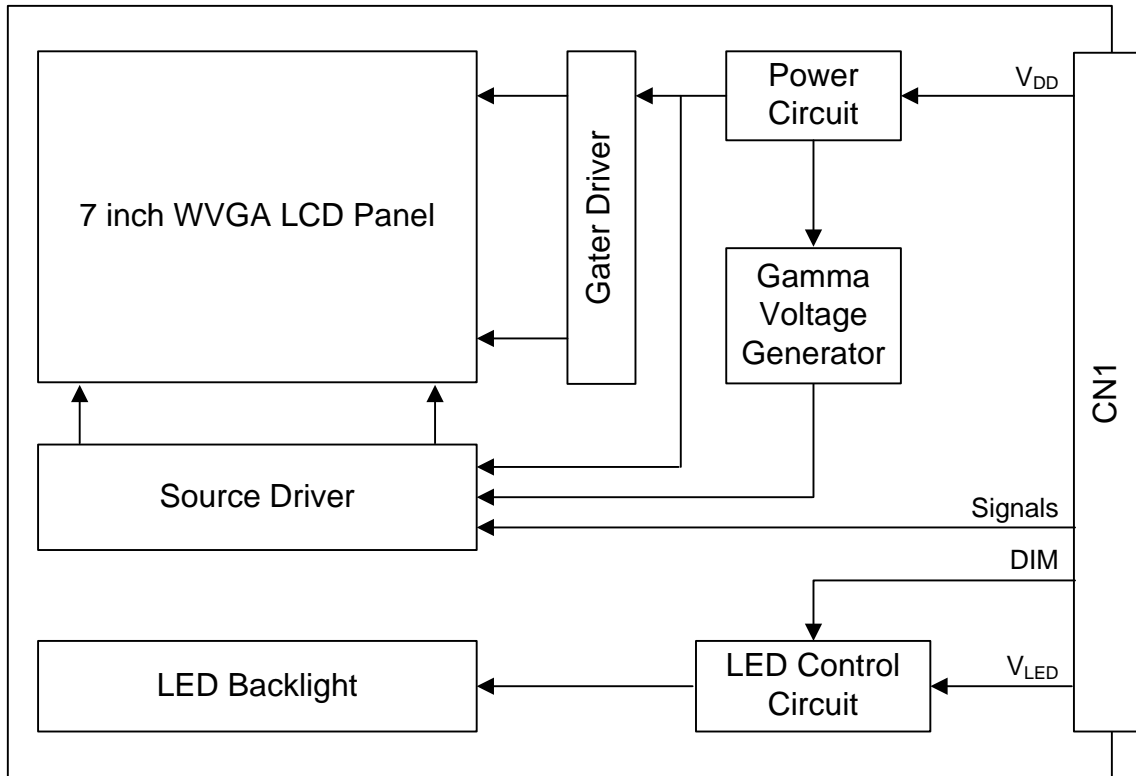

Fig 6.4

Note 6: The color chromaticity is measured from the center point of the panel, P5, as shown in Fig. 6.2.

7. BLOCK DIAGRAM



Note 1: Signals are a DE, Hsync, Vsync, CLK and RGB data bus.

8. RELIABILITY TESTS

Test Item	Condition	
High Temperature	1) Operating 2) 70 °C	240 hrs
Low Temperature	1) Operating 2) -20 °C	240 hrs
High Temperature	3) 1) Storage 4) 2) 80 °C	240 hrs
Low Temperature	5) 1) Storage 6) 2) -30 °C	240 hrs
Heat Cycle	1) Operating 2) -20 °C ~70 °C 3) 3hrs~1hr~3hrs	240 hrs
Thermal Shock	1) Non-Operating 2) -35 °C ↔ 85 °C 3) 0.5 hr ↔ 0.5 hr	240 hrs
High Temperature & Humidity	1) Operating 2) 40 °C & 85%RH 3) Without condensation	240 hrs (Note 3)
Vibration	1) Non-Operating 2) 20~200 Hz 3) 2G 4) X, Y, and Z directions	1 hr for each direction
Mechanical Shock	1) Non-Operating 2) 10 ms 3) 50G 4) ±X, ±Y and ±Z directions	Once for each direction
ESD	1) Operating 2) Tip: 150 pF, 330 Ω 3) Air discharge for glass: ± 8KV 4) Contact discharge for metal frame: ± 8KV	1) Glass: 9 points 2) Metal frame: 8 points (Note 4)

Note 1: Display functionalities are inspected under the conditions defined in the specification after the reliability tests.

Note 2: The display is not guaranteed for use in corrosive gas environments.

Note 3: Under the condition of high temperature & humidity, if the temperature is higher than 40 °C, the humidity needs to be reduced as Fig. 8.1 shown.

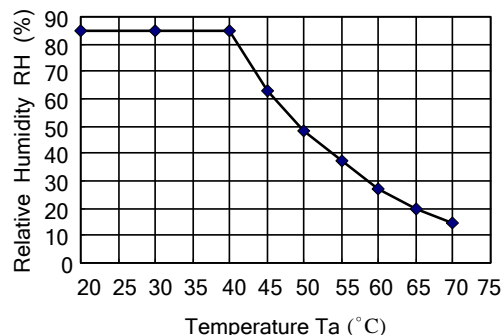

Fig. 8.1

Note 4: All pins of LCD interface (CN1) have been tested by ± 100V contact discharge of ESD under non-operating condition.

9. LCD INTERFACE

9.1 INTERFACE PIN CONNECTIONS

The display interface connector is FA5B040HP1R3000 made by JAE (Thickness: $0.3 \pm 0.05\text{mm}$; Pitch: $0.5 \pm 0.05\text{mm}$) and more details of the connector are shown in the section of outline dimension.

Pin assignment of LCD interface is as below:

Pin No.	Signal	Function	Pin No.	Signal	Function
1	V _{DD}	Power Supply for Logic	21	G4	Green Data
2	V _{DD}		22	G3	Green Data
3	UD	Vertical Display mode Control	23	V _{SS}	GND
4	LR	Horizontal Display mode Control	24	G2	Green Data
5	Hsync	Horizontal synchronous signal	25	G1	Green Data
6	DE	Data Enable Signal	26	G0	Green Data (LSB)
7	V _{SS}	GND	27	V _{SS}	GND
8	CLK	Dot Clock	28	R5	Red Data (MSB)
9	V _{SS}	GND	29	R4	Red Data
10	Vsync	Vertical synchronous signal	30	R3	Red Data
11	V _{SS}	GND	31	V _{SS}	GND
12	B5	Blue Data (MSB)	32	R2	Red Data
13	B4	Blue Data	33	R1	Red Data
14	B3	Blue Data	34	R0	Red Data (LSB)
15	V _{SS}	GND	35	V _{SS}	GND
16	B2	Blue Data	36	DIM	Brightness dimming (Note 3)
17	B1	Blue Data	37	V _{LED}	12VDC
18	B0	Blue Data (LSB)	38		
19	V _{SS}	GND	39		
20	G5	Green Data (MSB)	40		

Note 1: Please refer to [9.5 SCAN DIRECTION](#) for the setting methods of UD, LR function.

Note 2: Synchronous or DE mode would be automatically selected when signal input.

(Unused pins to be grounded.)

Note 3: Normal brightness: 0V or 100% PWM duty ; Brightness control: 0V to 3.3V DC or 0% to 100% PWM duty.

9.2 TIMING CHART

A. SYNCHRONOUS MODE

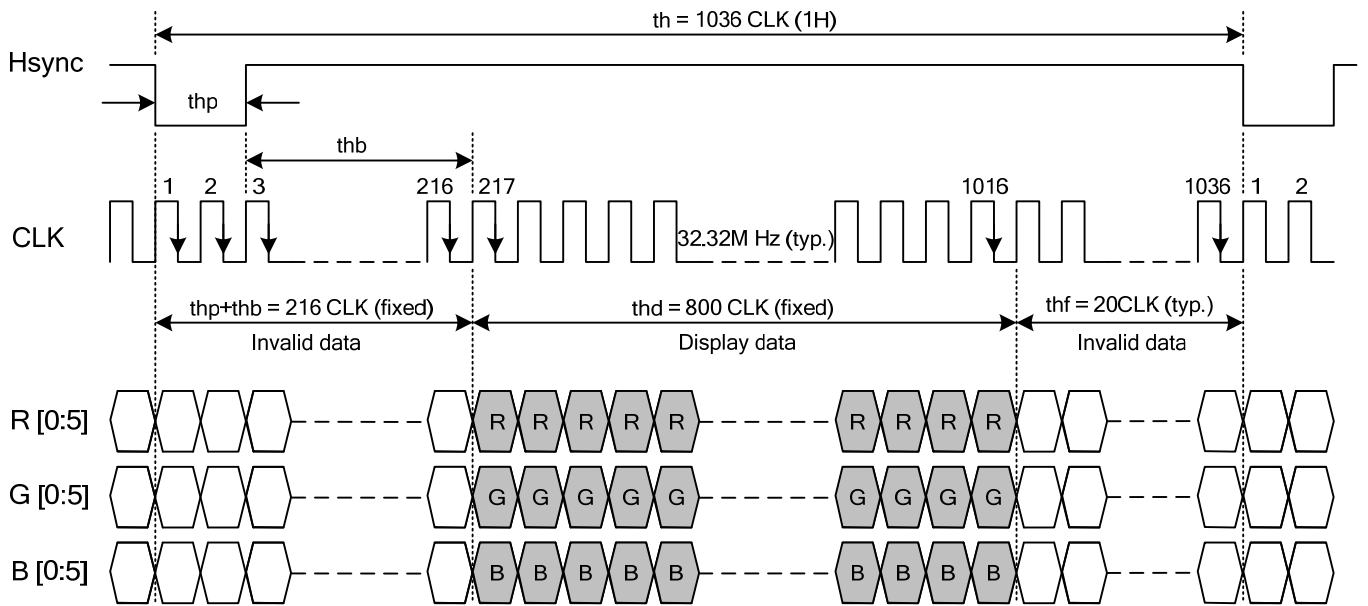

Fig. 9.1 Horizontal Timing

Note 1: CLK's falling edge is the time to latch data and count ($thp + thb$), therefore, data sending and Hsync's falling edge should start when CLK's rise edge

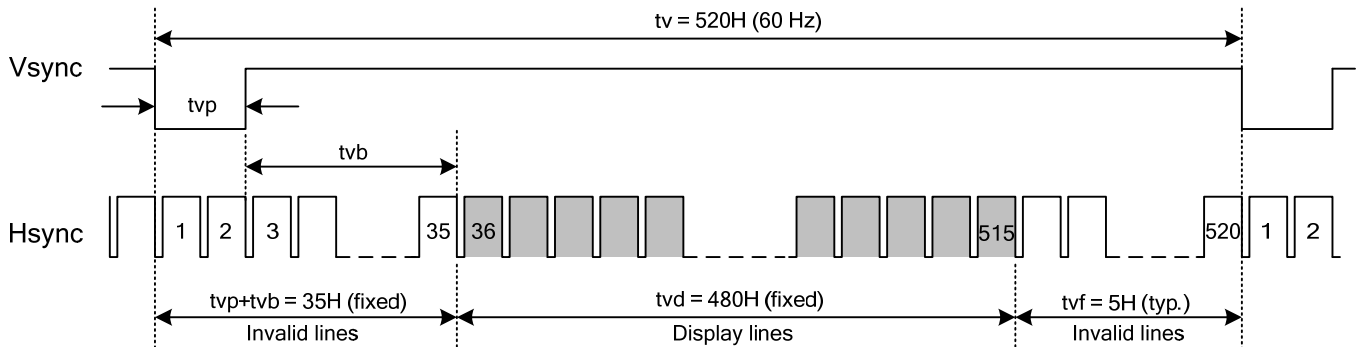

Fig. 9.2 Vertical Timing

Note 2: Vsync's falling edge needs to start with Hsync's falling edge simultaneously to count ($tvp + tvb$).

B. DE MODE

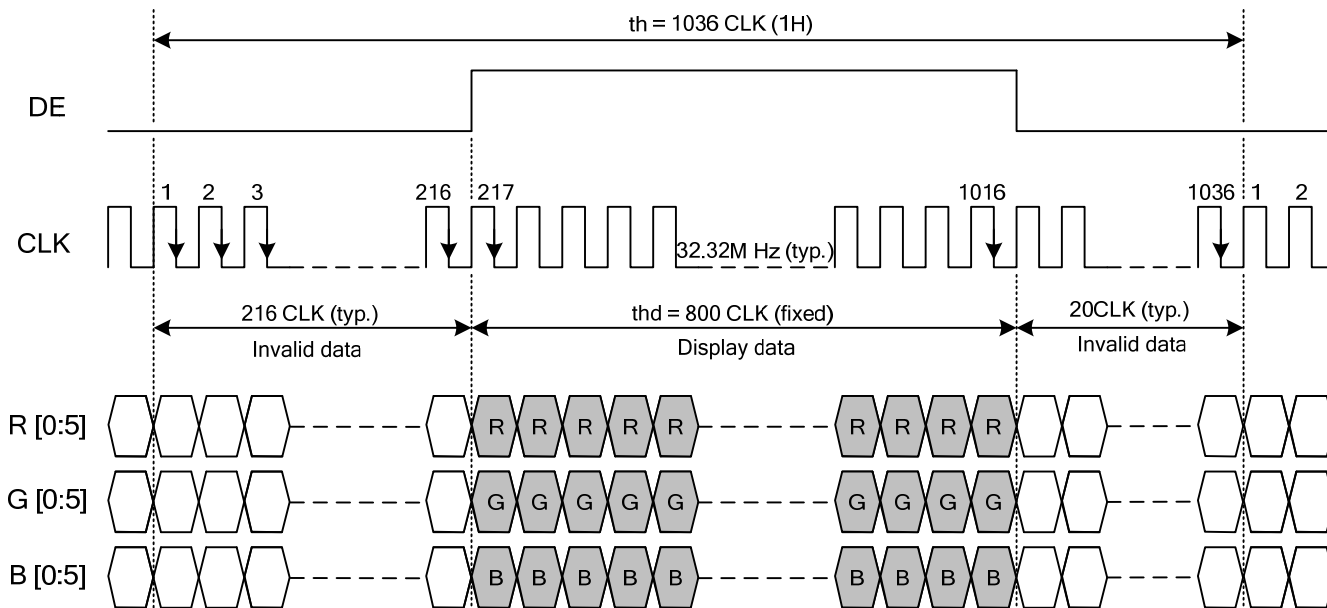

Fig. 9.3 Horizontal Timing

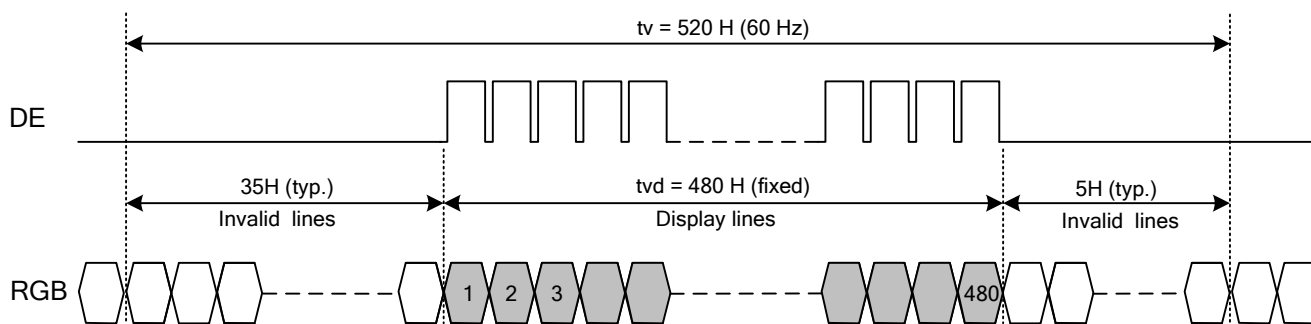

Fig. 9.4 Vertical Timing

C. CLOCK AND DATA INPUT TIMING

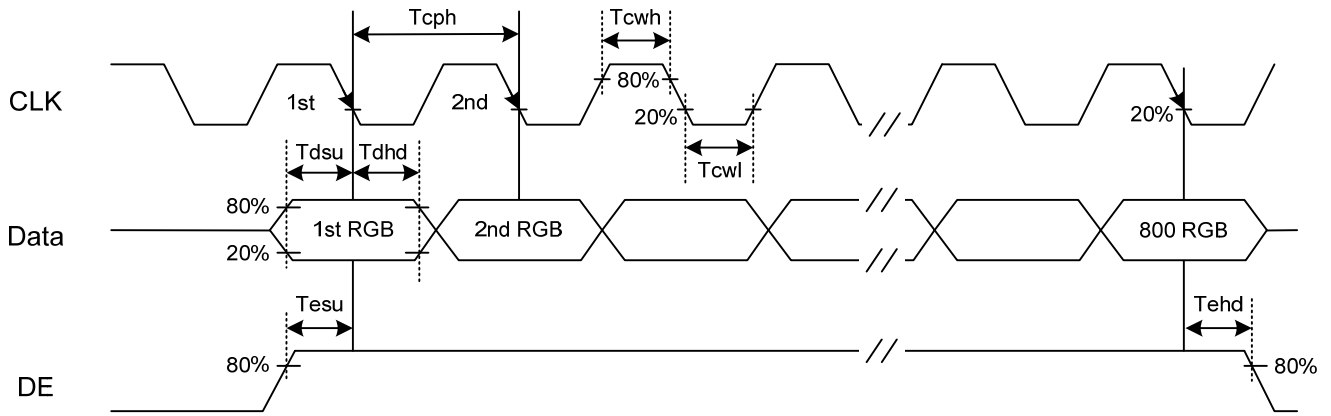

Fig. 9.5 Setup & Hold Time of Data and DE signal.

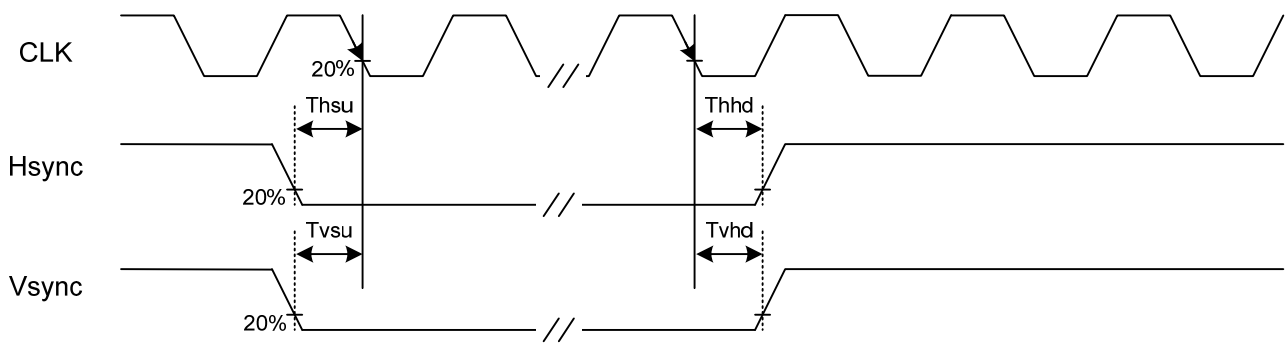

Fig. 9.6 Setup & Hold Time of Hsync and Vsync signal

9.3 TIMING TABLE

The column of timing sets including minimum, typical, and maximum as below are based on the best optical performance, frame frequency (f_{Frame}) = 60 Hz to define. If 60 Hz is not the aim to set, less than 66 Hz for f_{Frame} is recommended to apply for better performance by other parameter combination as the definitions in section 5.1.

A. SYNCHRONOUS MODE

Item	Symbol	Min.	Typ.	Max.	Unit	
Hsync	CLK Frequency	fclk	29.0	32.32	36.15	M Hz
	Display Data	thd	800	800	800	
	Cycle Time	th	1020	1036	1057	
	Pulse Width	thp	1	128	-	
	Pulse Width and Back Porch	thp + thb	216	216	216	
	Front Porch	thf	4	20	41	
Vsync	Display Line	tvd	480	480	480	H
	Cycle Time	tv	517	520	526	
	Pulse Width	tvp	1	2	-	
	Pulse Width and Back Porch	tvp + tvb	35	35	35	
	Front Porch	tvf	2	5	11	

B. DE MODE

Item	Symbol	Min.	Typ.	Max.	Unit	
Horizontal	CLK Frequency	fclk	29.0	32.32	36.15	M Hz
	Display Data	thd	800			
	Cycle Time	th	1020	1036	1057	
Vertical	Display Data	tvd	480			H
	Cycle Time	tv	517	520	526	

C. CLOCK AND DATA INPUT TIMING

Item	Symbol	Min.	Typ.	Max.	Unit	
CLK	Duty	Tcwh	40	50	60	%
	Cycle Time	Tcph	-	30.94	-	
Vsync	Setup Time	Tvsu	6	-	-	ns
	Hold Time	Tvhd	6	-	-	
Hsync	Setup Time	Thsu	6	-	-	
	Hold Time	Thhd	6	-	-	
Data	Setup Time	Tdsu	6	-	-	
	Hold Time	Tdhd	6	-	-	
DE	Setup Time	Tesu	6	-	-	
	Hold Time	Tehd	6	-	-	

9.4 POWER SEQUENCE

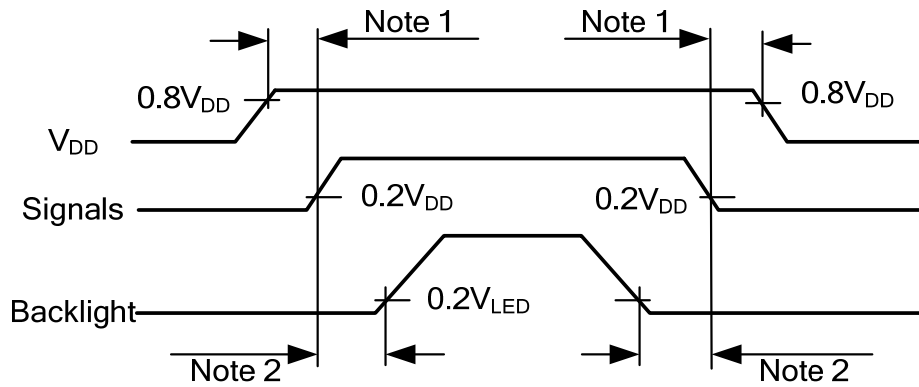

Note 1: In order to avoid any damages, V_{DD} has to be applied before all other signals. The opposite is true for power off where V_{DD} has to be remained on until all other signals have been switch off. The recommended time period is 1 second.

Note 2: In order to avoid showing uncompleted patterns in transient state. It is recommended that switching the backlight on is delayed for 1 second after the signals have been applied. The opposite is true for power off where the backlight has to be switched off 1 second before the signals are removed.

9.5 SCAN DIRECTION

Scan direction is available to be switched as below by setting CN1's UD & LR pin.

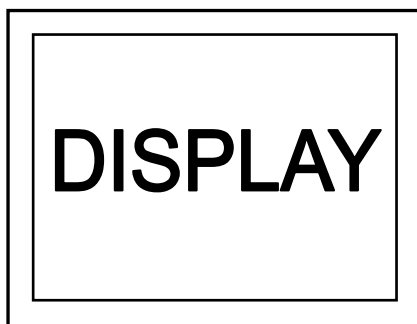

UD : L or Open ; LR : H or Open



UD : L or Open ; LR : L



UD : H ; LR : H or Open



UD : H ; LR : L

9.6 DATA INPUT for DISPLAY COLOR

Input color		Red Data						Green Data						Blue Data					
		R5	R4	R3	R2	R1	R0	G5	G4	G3	G2	G1	G0	B5	B4	B3	B2	B1	B0
		MSB			LSB			MSB			LSB			MSB				LSB	
Basic Color	Black	0	0	0	0	0	0	0	0	0	0	0	0	0	0	0	0	0	0
	Red(63)	1	1	1	1	1	1	0	0	0	0	0	0	0	0	0	0	0	0
	Green(63)	0	0	0	0	0	0	1	1	1	1	1	1	0	0	0	0	0	0
	Blue(63)	0	0	0	0	0	0	0	0	0	0	0	0	1	1	1	1	1	1
	Cyan	0	0	0	0	0	0	1	1	1	1	1	1	1	1	1	1	1	1
	Magenta	1	1	1	1	1	1	0	0	0	0	0	0	1	1	1	1	1	1
	Yellow	1	1	1	1	1	1	1	1	1	1	1	1	0	0	0	0	0	0
	White	1	1	1	1	1	1	1	1	1	1	1	1	1	1	1	1	1	1
Red	Black	0	0	0	0	0	0	0	0	0	0	0	0	0	0	0	0	0	0
	Red (1)	0	0	0	0	0	1	0	0	0	0	0	0	0	0	0	0	0	0
	Red (2)	0	0	0	0	1	0	0	0	0	0	0	0	0	0	0	0	0	0
	:	:	:	:	:	:	:	:	:	:	:	:	:	:	:	:	:	:	:
	:	:	:	:	:	:	:	:	:	:	:	:	:	:	:	:	:	:	:
	Red (62)	1	1	1	1	1	0	0	0	0	0	0	0	0	0	0	0	0	0
	Red (63)	1	1	1	1	1	1	0	0	0	0	0	0	0	0	0	0	0	0
Green	Black	0	0	0	0	0	0	0	0	0	0	0	0	0	0	0	0	0	0
	Green (1)	0	0	0	0	0	0	0	0	0	0	0	1	0	0	0	0	0	0
	Green (2)	0	0	0	0	0	0	0	0	0	0	1	0	0	0	0	0	0	0
	:	:	:	:	:	:	:	:	:	:	:	:	:	:	:	:	:	:	:
	:	:	:	:	:	:	:	:	:	:	:	:	:	:	:	:	:	:	:
	Green (62)	0	0	0	0	0	0	1	1	1	1	1	0	0	0	0	0	0	0
	Green (63)	0	0	0	0	0	0	1	1	1	1	1	1	0	0	0	0	0	0
Blue	Black	0	0	0	0	0	0	0	0	0	0	0	0	0	0	0	0	0	0
	Blue (1)	0	0	0	0	0	0	0	0	0	0	0	0	0	0	0	0	0	1
	Blue (2)	0	0	0	0	0	0	0	0	0	0	0	0	0	0	0	0	1	0
	:	:	:	:	:	:	:	:	:	:	:	:	:	:	:	:	:	:	:
	:	:	:	:	:	:	:	:	:	:	:	:	:	:	:	:	:	:	:
	Blue (62)	0	0	0	0	0	0	0	0	0	0	0	0	1	1	1	1	1	0
	Blue (63)	0	0	0	0	0	0	0	0	0	0	0	0	1	1	1	1	1	1

10. OUTLINE DIMENSIONS

10.1 FRONT VIEW

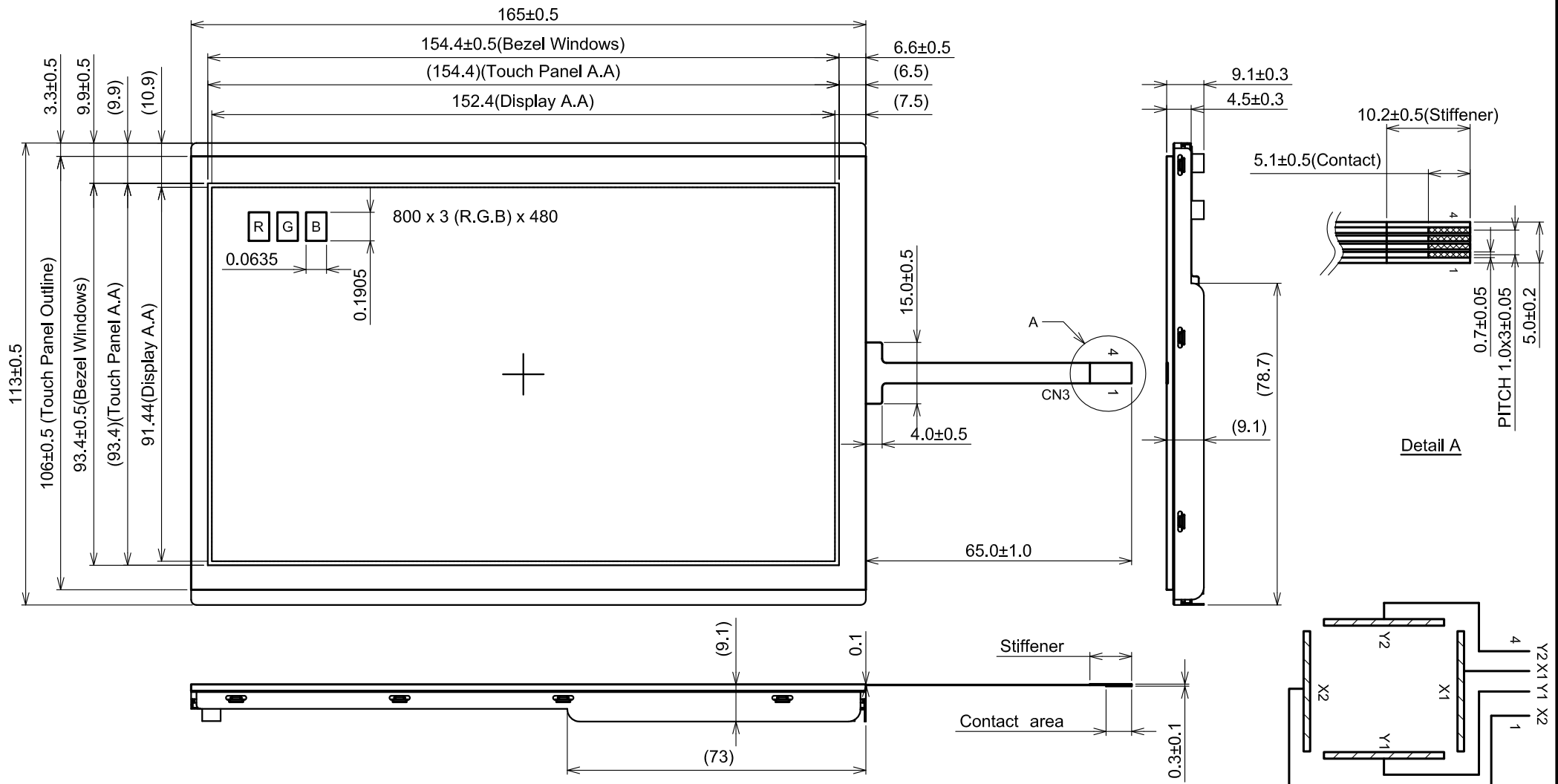

General tolerance is ± 0.5 mm
 Scale : NTS
 Unit : mm

10.2 REAR VIEW

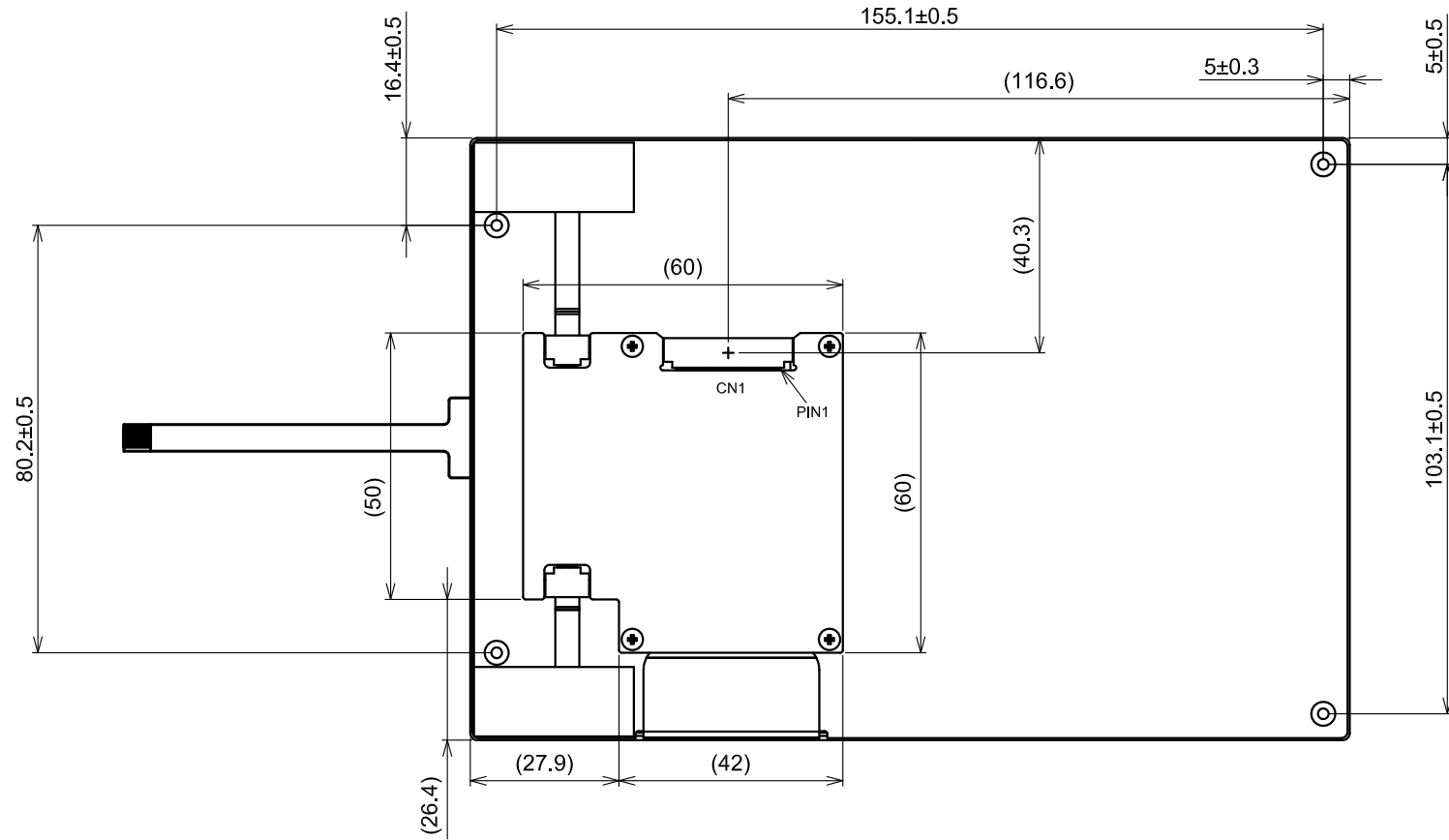

General tolerance is ± 0.5 mm
 Scale : NTS
 Unit : mm

11. TOUCH PANEL

The type of touch panel used on this display is resistive, analog, 5-wire and film on glass, and more characteristics are shown as below:

11.1 OPERATING CONDITIONS

Item	Specification	Remarks
Operating Voltage	5VDC	-

11.2 ELECTRICAL CHARACTERISTICS

Item	Specification	Remarks
Resistance Between Terminal	X1-X2	300~1400 Ω
	Y1-Y2	100~900 Ω
Insulation Resistance	X-Y	20MΩ min.
Linearity	X	±1.5% max.
	Y	±1.5% max.
Chattering		10ms max.

Note 1: The test conditions and equipments of linearity are as below:

- Material of pen: poly-acetal resin
- End shape: R 0.8 mm
- Test force: 150 gf
- Pitch: 10 mm
- Test area is shown in Fig. 11.1

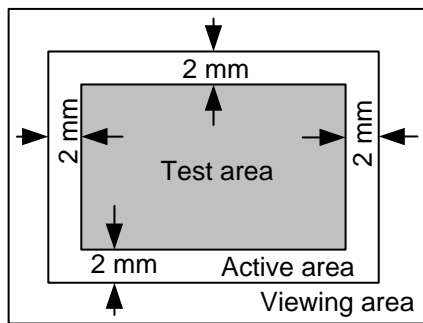

Fig. 11.1

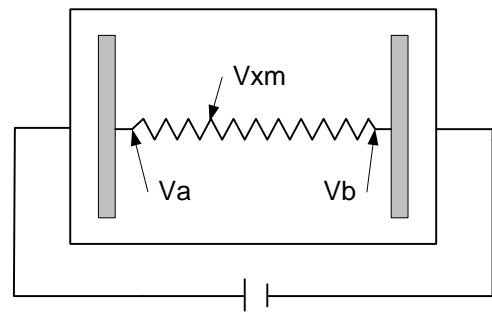

Fig. 11.2

As shown in Fig. 11.2, applying voltage meter to measure Va, Vb and Vxm, where Va is the maximum voltage in the active area; Vb is the minimum voltage in the active area; Vxm is the measured voltage of point x selected by random. Afterwards, the linearity can be calculated by following equation:

$$Linearity = \frac{|V_{xi} - V_{xm}|}{V_a - V_b} \times 100\%$$

where Vxi is the idea voltage of point x.

The method to measure the linearity of Y-axis is the same as above.

11.3 MECHANICAL CHARACTERISTICS

Item	Specification	Remarks
Pen Input Pressure	50 ~ 150 g	R0.8, Polyacetal Pen
Finger	50 ~ 150 g	R8.0, Silicon Rubber
Surface Hardness	3H min.	JIS K 5400

11.4 OPTICAL CHARACTERISTICS

Item	Specification	Remarks
Transmittance	77% min.	-

11.5 SAFETY AND ATTENTIONS

- 1) Do not put heavy shock or stress on the touch panel.
- 2) Please use soft cloth or absorbent cotton with ethanol to clean the touch panel by gently wiping. Moreover, please wipe it by horizontal or vertical direction instead of circling to prevent leaving scars on the touch panel's surface.
- 3) Do not use any harmful chemicals such as acetone, toluene, and isopropyl alcohol to clean the display's surface.
- 4) Please pay more attention on handling and assembly due to that the touch panel overhung this TFT display outline.
- 5) Please ensure housing design is able to protect touch panel when unexpected pressure adding on the edges and corners of it.
- 6) UV protection is recommended to avoid the possibility of performance degrading when touch panel is likely applied under UV environment for a long period of time.

12. APPEARANCE STANDARD

The appearance inspection is performed in a room around 500~1000 lx based on the conditions as below:

- The distance between inspector's eyes and display is 30 cm.
- The viewing zone is defined with angle θ shown in Fig.12.1 The inspection should be performed within 45° when display is shut down. The inspection should be performed within 5° when display is power on.

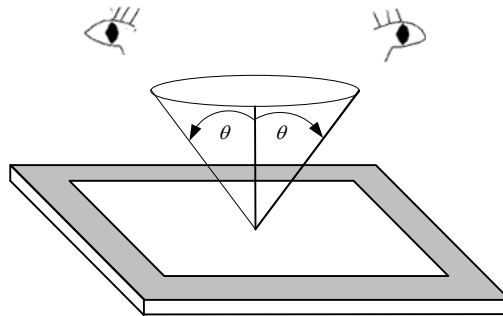

Fig. 12.1

12.1 THE DEFINITION OF LCD ZONE

LCD panel is divided into 3 areas as shown in Fig.12.2 for appearance specification in next section. A zone is the LCD active area (dot area); B zone is the area between A zone and metal frame.

In terms of housing design, B zone is the recommended window area customers' housing should be located in.

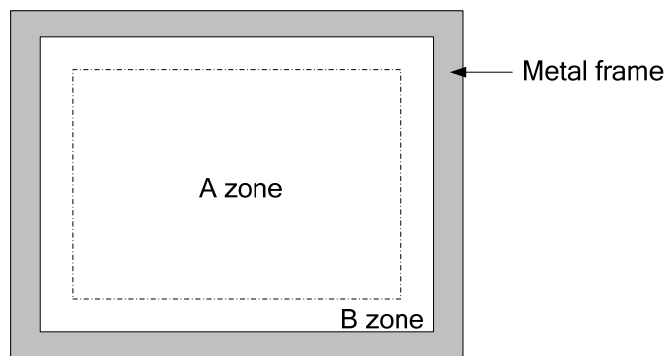

Fig. 12.2

12.2 LCD APPEARANCE SPECIFICATION

The specification as below is defined as the amount of unexpected phenomenon or material in different zones of LCD panel. The definitions of length, width and average diameter using in the table are shown in Fig. 12.3 and Fig. 12.4.

Item	Criteria				Applied zone
	Length (mm)	Width (mm)	Maximum number	Minimum space	
Scratches	Ignored	$W \leq 0.01$	Ignored	-	A、B
	$L \leq 40$	$W \leq 0.02$	10	-	
	$L \leq 20$	$W \leq 0.04$	10	-	
	Round (Dot Shape)				
	Average diameter (mm)		Maximum number	Minimum space	
	$D \leq 0.2$		Ignore	-	
	$D \leq 0.4$		10	-	
	Dent	Serious one is not allowed			
Wrinkles in polarizer	Serious one is not allowed				A
Bubbles on polarizer	Average diameter (mm)		Maximum number		A
	$D \leq 0.3$		Ignored		
	$D \leq 0.5$		10		
	$D \leq 1.0$		5		
1) Stains 2) Foreign Materials 3) Dark Spot	Filamentous (Line shape)				A、B
	Length (mm)	Width (mm)	Maximum number		
	Ignored	$W \leq 0.02$	Ignored		
	$L \leq 2.0$	$W \leq 0.03$	10		
	$L \leq 1.0$	$W \leq 0.06$	10		
	Round (Dot shape)				A、B
	Average diameter (mm)		Maximum number	Minimum Space	
	$D \leq 0.22$		Ignored	-	
	$D \leq 0.33$		5	-	
	$D > 0.33$		0	-	
	In total	Filamentous + Round=10			
	Those wiped out easily are acceptable				
Dot-Defect		Type	Maximum number		A (Note 1)
	Bright dot-defect	1 dot	4		
		2 adjacent dot	1		
		3 adjacent dot or above	Not allowed		
		Density	$2/\phi 20\text{mm}$		
		In total	5		
	Dark dot-defect	1 dot	5		
		2 adjacent dot	2		
		3 adjacent dot or above	Not allowed		
		Density	$3/\phi 20\text{mm}$		
		In total	5		
	In total		10		

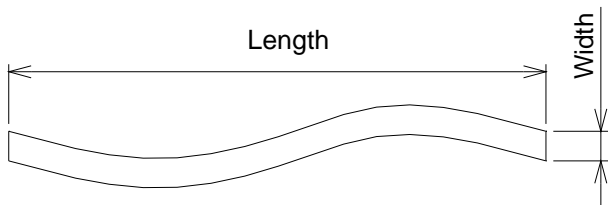

Fig 12.3

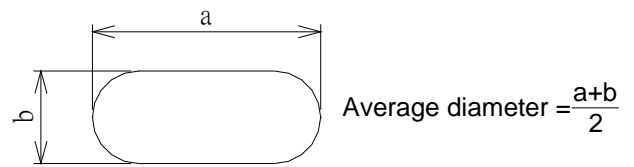

Fig 12.4

Note 1: The definitions of dot defect are as below:

- The defect area of the dot must be bigger than half of a dot.
- For bright dot-defect, showing black pattern, the dot's brightness must be over 30% brighter than others.
- For dark dot-defect, showing white pattern, the dot's brightness must be under 70% darker than others.
- The definition of 1-dot-defect is the defect-dot, which is isolated and no adjacent defect-dot.
- The definition of adjacent dot is shown as Fig. 12.5.
- The Density of dot defect is defined in the area within diameter $\phi = 20\text{mm}$.

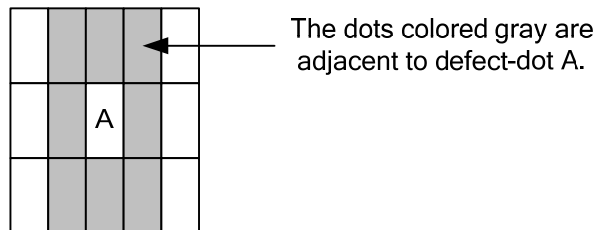

Fig. 12.5

12.3 TOUCH PANEL APPEARANCE SPECIFICATION

The specification as below is defined by the amount of unexpected material in different zones of touch panel.

Item	Criteria			Applied zone
	Width (mm)	Length (mm)	Maximum number	
Scratches	$W \geq 0.10$	$L \geq 10$	Not allowed	A
	$0.10 > W \geq 0.05$	$L < 10$	4 pcs max.	
	$0.05 < W$	$L < 10$	Ignored	
Foreign Materials	Filamentous (Line shape)			A
	Width (mm)	Length (mm)	Maximum number	
	$W > 0.05$	$L > 3$	Not allowed	
	$0.05 \geq W$	$L \leq 3$	Ignored	A
	Round (Dot shape)			
	Average diameter (mm)	Maximum number		
	$D > 0.3$	Not allowed		
	$0.3 \geq D > 0.2$	3 pcs max.		
	$0.2 \geq D > 0.1$	5 pcs max.		
	$0.1 \geq D$	Ignored		
$D \leq 0.5$	Ignored		B	

The limitation of glass flaw occurred on touch panel is defined in the table as below.

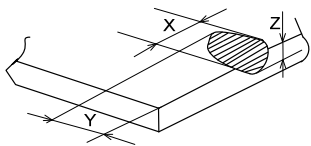
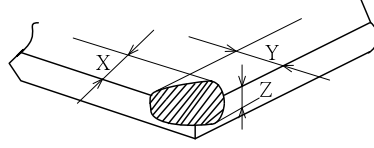
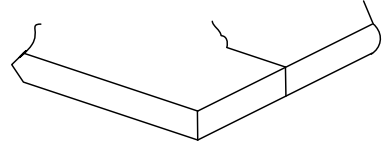
Item	Specifications	
Edge flaw		$X \leq 3.0 \text{ mm}$ $Y \leq 3.0 \text{ mm}$ $Z \leq \text{Thickness}$
Corner flaw		$X \leq 3.0 \text{ mm}$ $Y \leq 3.0 \text{ mm}$ $Z \leq \text{Thickness}$
Progressive flaw		Not allowed

13. PRECAUTIONS

13.1 PRECAUTIONS of MOUNTING

1) Please refer to Fig. 13.1 for housing the display with touch panel into applications. The Fig. 13.1 shows some points as below:

- The cushion needs to be designed between housing and touch panel in order to avoid unexpected pressure to cause any wrong reactions, and the cushion should be located in the insulated area.
- The housing should not cover the active area of touch panel as the figure shown.

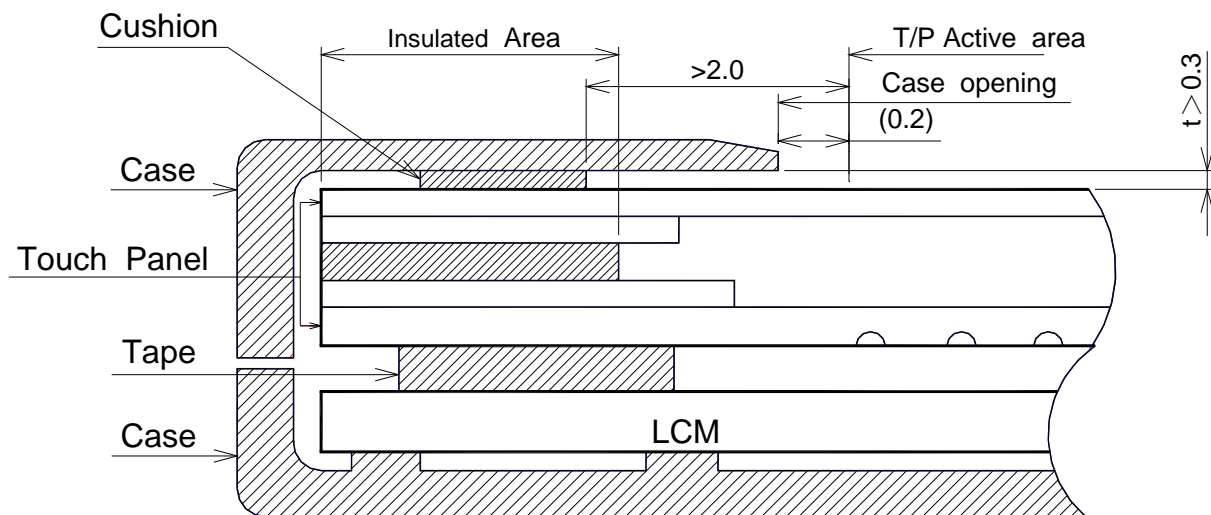

Fig 13.1

13.2 PRECAUTIONS of ESD

- 1) Before handling the display, please ensure your body has been connected to ground to avoid any damages by ESD. Also, do not touch display's interface directly when assembling.
- 2) Please remove the protection film very slowly before turning on the display to avoid generating ESD.

13.3 PRECAUTIONS of HANDLING

- 1) In order to keep the appearance of display in good condition, please do not rub any surfaces of the displays by sharp tools harder than 3H, especially touch panel, metal frame and polarizer.
- 2) Please do not stack the displays as this may damage the surface. In order to avoid any injuries, please avoid touching the edge of the glass or metal frame and wore gloves during handling.
- 3) Touching the polarizer or terminal pins with bare hand should be avoided to prevent staining and poor electrical contact.
- 4) Do not use any harmful chemicals such as acetone, toluene, and isopropyl alcohol to clean display's surfaces.
- 5) Please use soft cloth or absorbent cotton with ethanol to clean the display by gently wiping. Moreover, when wiping the display, please wipe it by horizontal or vertical direction instead of circling to prevent leaving scars on the display's surface, especially polarizer.
- 6) Please wipe any unknown liquids immediately such as saliva, water or dew on the display to avoid color fading or any permanently damages.

- 7) Maximum pressure to the surface of the display must be less than 1.96×10^4 Pa. If the area of adding pressure is less than 1 cm^2 , the maximum pressure must be less than 1.96N.

13.4 PRECAUTIONS OF OPERATING

- 1) Please input signals and voltages to the displays according to the values defined in the section of electrical characteristics to obtain the best performance. Any voltages over than absolute maximum rating will cause permanent damages to this display. Also, any timing of the signals out of this specification would cause unexpected performance.
- 2) When the display is operating at significant low temperature, the response time will be slower than it at 25°C . In high temperature, the color will be slightly dark and blue compared to original pattern. However, these are temperature-related phenomenon of LCD and it will not cause permanent damages to the display when used within the operating temperature.
- 3) The use of screen saver or sleep mode is recommended when static images are likely for long periods of time. This is to avoid the possibility of image sticking.
- 4) Spike noise can cause malfunction of the circuit. The recommended limitation of spike noise is no bigger than $\pm 100 \text{ mV}$.

13.5 PRECAUTIONS of STORAGE

If the displays are going to be stored for years, please be aware the following notices.

- 1) Please store the displays in a dark room to avoid any damages from sunlight and other sources of UV light.
- 2) The recommended long term storage temperature is between $10^\circ\text{C} \sim 35^\circ\text{C}$ and 55%~75% humidity to avoid causing bubbles between polarizer and LCD glasses, and polarizer peeling from LCD glasses.
- 3) It would be better to keep the displays in the container, which is shipped from KOE, and do not unpack it.
- 4) Please do not stick any labels on the display surface for a long time, especially on the polarizer.

14. DESIGNATION of LOT MARK

1) The lot mark is showing in Fig.14.1. First 4 digits are used to represent production lot, T represented made in Taiwan, and the last 6 digits are the serial number.

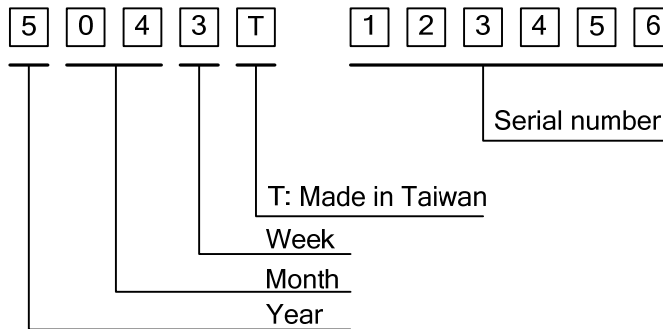

Fig. 14.1

2) The tables as below are showing what the first 4 digits of lot mark are shorted for.

Year	Lot Mark
2015	5
2016	6
2017	7
2018	8
2019	9

Month	Lot Mark	Month	Lot Mark
Jan.	01	Jul.	07
Feb.	02	Aug.	08
Mar.	03	Sep.	09
Apr.	04	Oct.	10
May	05	Nov.	11
Jun.	06	Dec.	12

Week	Lot Mark
1~7 days	1
8~14 days	2
15~21 days	3
22~28 days	4
29~31 days	5

- 3) Except letters I and O, revision number will be shown on lot mark and following letters A to Z.
- 4) The location of the lot mark is on the back of the display shown in Fig. 14.2.

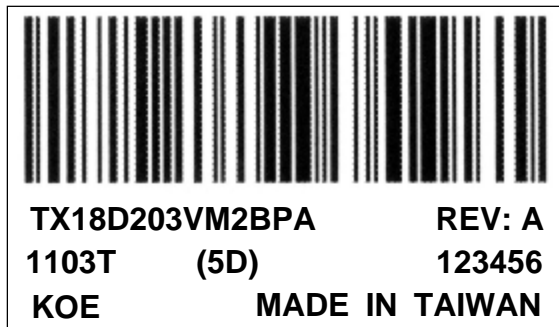

Fig. 14.2

DATA MODUL



ALL TECHNOLOGIES. ALL COMPETENCIES. ONE SPECIALIST.



DATA MODUL AG
Landsberger Straße 322
DE-80687 Munich
Phone: +49-89-56017-0

DATA MODUL WEIKERSHEIM GMBH
Lindenstraße 8
DE-97990 Weikersheim
Phone: +49-7934-101-0



More information and worldwide locations can be found at

www.data-modul.com