



SPECIFICATION



TX38D203VM0BAA

15" - WHD - LVDS

Version:

Date: 05.02.2021

Note: This specification is subject to change without prior notice

TENTATIVE

KOE

JDI Group

Kaohsiung Opto-Electronics Inc.

FOR MESSRS : _____

DATE : Feb. 5th, 2021

TECHNICAL DATA

TX38D203VM0BAA

Contents

No.	ITEM	SHEET No.	PAGE
1	COVER	7B64LTD - 2687 -1	1-1/1
2	RECORD OF REVISION	7B64LTD - 2687 -1	2-1/1
3	GENERAL DATA	7B64LTD - 2687 -1	3-1/1
4	ABSOLUTE MAXIMUM RATINGS	7B64LTD - 2687 -1	4-1/1
5	ELECTRICAL CHARACTERISTICS	7B64LTD - 2687 -1	5-1/2~2/2
6	OPTICAL CHARACTERISTICS	7B64LTD - 2687 -1	6-1/2~2/2
7	BLOCK DIAGRAM	7B64LTD - 2687 -1	7-1/1
8	RELIABILITY TESTS	7B64LTD - 2687 -1	8-1/1
9	LCD INTERFACE	7B64LTD - 2687 -1	9-1/12~12/12
10	OUTLINE DIMENSIONS	7B64LTD - 2687 -1	10-1/2~2/2

ACCEPTED BY: _____

PROPOSED BY: Oblack Tsai

2. RECORD OF REVISION

DATE	SHEET No.	SUMMARY

3. GENERAL DATA

3.1 DISPLAY FEATURES

This module is a 15" WHD of 13:5 format amorphous silicon TFT. The pixel format is vertical stripe and sub pixels are arranged as R (red), G (green), B (blue) sequentially. This display is RoHS compliant, COG (chip on glass) technology and LED backlight are applied on this display.

Part Name	TX38D203VM0BAA
Module Dimensions	374.5(W) mm x 154.5(H) mm x 18.15 (D) mm
LCD Active Area	355.68(W) mm x 133.38(H) mm
Pixel Pitch	0.18525(W) mm x 0.18525 (H) mm
Resolution	1920 x 3(RGB)(W) x 720(H) Dots
Color Pixel Arrangement	R, G, B Vertical Stripe
LCD Type	Transmissive Color TFT; Normally Black
Display Type	Active Matrix
Number of Colors	16.7M Colors
Backlight	Light Emitting Diode (LED)
Weight	(900) g
Interface	1ch LVDS; 60 pins
Power Supply Voltage	3.3V for LCD; 24.2V for Backlight
Power Consumption	TBD W for LCD; TBD W for Backlight
Viewing Direction	Super Wide Version (In-Plane Switching)

4. ABSOLUTE MAXIMUM RATINGS

Item	Symbol	Min.	Max.	Unit	Remarks
Supply Voltage	V _{DD}	-0.3	4.0	V	-
Input Voltage of Logic	V _I	-0.3	V _{DD} +0.3	V	Note 1
Operating Temperature	T _{op}	-40	85	°C	Note 2
Storage Temperature	T _{st}	-40	90	°C	Note 2

Note 1: The rating is defined for the signal voltages of the interface such as CLK and pixel data pairs.

Note 2: The maximum rating is defined as above based on the chamber temperature, which might be different from ambient temperature after assembling the panel into the application. Moreover, some temperature-related phenomenon as below needed to be noticed:

- Background color, contrast and response time would be different in temperatures other than 25 °C.
- Operating under high temperature will shorten LED lifetime.

5. ELECTRICAL CHARACTERISTICS

5.1 LCD CHARACTERISTICS

$T_a = 25\text{ }^\circ\text{C}$, $V_{SS} = 0\text{V}$

Item	Symbol	Condition	Min.	Typ.	Max.	Unit	Remarks
Power Supply Voltage	V_{DD}	-	-	3.3	-	V	-
Differential Input Voltage for LVDS Receiver Threshold	V_I	"H" level	-	-	+50	mV	Note 1
		"L" level	-50	-	-		
Power Supply Current	I_{DD}	$V_{DD}=3.3\text{V}$	-	TBD	-	mA	Note 2
Frame Frequency	f_{Frame}	-	-	60	62	Hz	
CLK Frequency	f_{CLK}	-	85	-	104	MHz	

Note 1: VCM 1.2V is common mode voltage of LVDS transmitter and receiver. The input terminal of LVDS receiver is terminated with 100Ω .

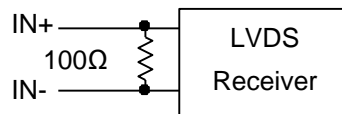

Note 2: An all white check pattern is used when measuring I_{DD} . f_{Frame} is set to 60 Hz. Moreover, TBD A fuse is applied in the module for I_{DD} . For display activation and protection purpose, power supply is recommended larger than TBD A to start the display and break fuse once any short circuit occurred.

5.2 BACKLIGHT CHARACTERISTICS

$T_a = 25^\circ\text{C}$

Item	Symbol	Condition	Min.	Typ.	Max.	Unit	Remarks
LED Input Voltage	V_{LED}	-	-	24.2	27.2	V	Note1
LED Forward Current	I_{LED}	-	-	(80)	-	mA	
LED lifetime	-	$I_{LED} = 480\text{ mA}$	-	70K	-	hrs	Note 2
Thermistor type	-	-	NTC 10K			-	Note 3

Note 1: As Fig. 5.1 shown, LED current is constant, (80) mA, controlled by the LED Input Voltage when applying 24.2 V.

Note 2: The estimated lifetime is specified as the time to reduce 50% brightness by applying (80) mA at 25°C .

Note 3. Position:near LED.

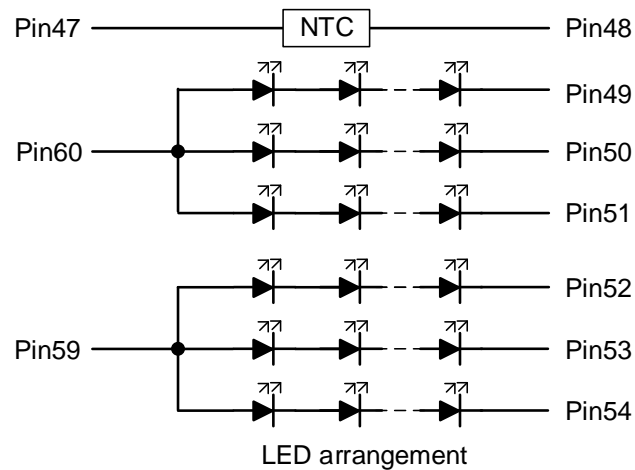

Fig 5.1

6. OPTICAL CHARACTERISTICS

The optical characteristics are measured based on the conditions as below:

- Supplying the signals and voltages defined in the section of electrical characteristics.
- The backlight unit needs to be turned on for 30 minutes.
- The ambient temperature is 25 °C .
- In the dark room less than 100 lx, the equipment has been set for the measurements as shown in Fig 6.1.

$$T_a = 25\text{ }^{\circ}\text{C}, f_{Frame} = 60\text{ Hz}, V_{DD} = 3.3\text{V}$$

Item	Symbol	Condition	Min.	Typ.	Max.	Unit	Remarks
Brightness of White	-	$\phi = 0^{\circ}, \theta = 0^{\circ}$, $I_{LED} = 480\text{ mA}$	850	1000	-	cd/m ²	Note 1
Brightness Uniformity	-		80	-	-	%	Note 2
Contrast Ratio	CR		800	1000	-	-	Note 3
Response Time	$T_r + T_f$	$\phi = 0^{\circ}, \theta = 0^{\circ}$	-	-	30	ms	Note 4
NTSC Ratio	-	$\phi = 0^{\circ}, \theta = 0^{\circ}$	-	70	-	%	-
Viewing Angle	θ_x	$\phi = 0^{\circ}, CR \geq 10$	-	85	-	Degree	Note 5
	$\theta_{x'}$	$\phi = 180^{\circ}, CR \geq 10$	-	85	-		
	θ_y	$\phi = 90^{\circ}, CR \geq 10$	-	85	-		
	$\theta_{y'}$	$\phi = 270^{\circ}, CR \geq 10$	-	85	-		
Color Chromaticity	Red	X	-	0.640	-	-	Note 6
		Y	-	0.330	-		
	Green	X	-	0.300	-		
		Y	-	0.600	-		
	Blue	X	-	0.150	-		
		Y	-	0.060	-		
	White	X	-	0.313	-		
		Y	-	0.329	-		

Note 1: The brightness is measured from the center point of the panel, P5 in Fig. 6.2, for the typical value.

Note 2: The brightness uniformity is calculated by the equation as below:

$$\text{Brightness uniformity} = \frac{\text{Min. Brightness}}{\text{Max. Brightness}} \times 100\%$$

which is based on the brightness values of the 9 points in active area measured by BM-5 as shown in Fig. 6.2.

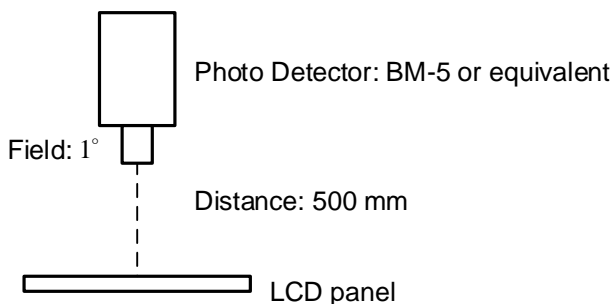

Fig 6.1

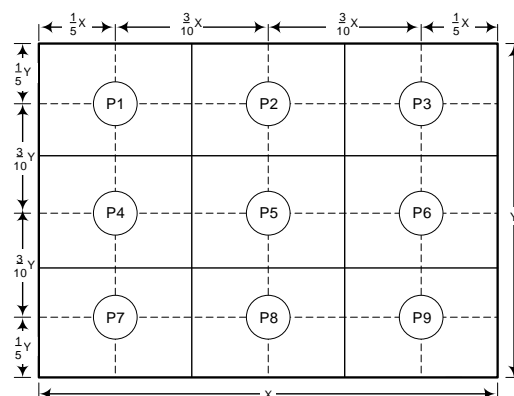

Fig 6.2

Note 3: The Contrast Ratio is measured from the center point of the panel, P5, and defined as the following equation:

$$CR = \frac{\text{Brightness of White}}{\text{Brightness of Black}}$$

Note 4: The definition of response time is shown in Fig. 6.3. The rising time is the period from 10% brightness to 90% brightness when the data is from black to white. Oppositely, Falling time is the period from 90% brightness falling to 10% brightness.

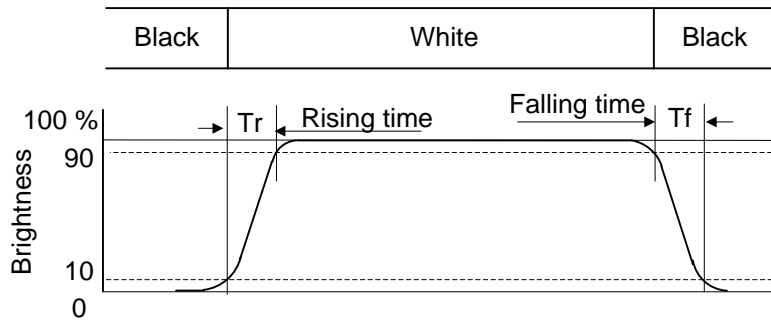

Fig.6.3

Note 5: The definition of viewing angle is shown in Fig. 6.4. Angle ϕ is used to represent viewing directions, for instance, $\phi = 270^\circ$ means 6 o'clock, and $\phi = 0^\circ$ means 3 o'clock. Moreover, angle θ is used to represent viewing angles from axis Z toward plane XY.

The display is super wide viewing angle version, so that the best optical performance can be obtained from every viewing direction.

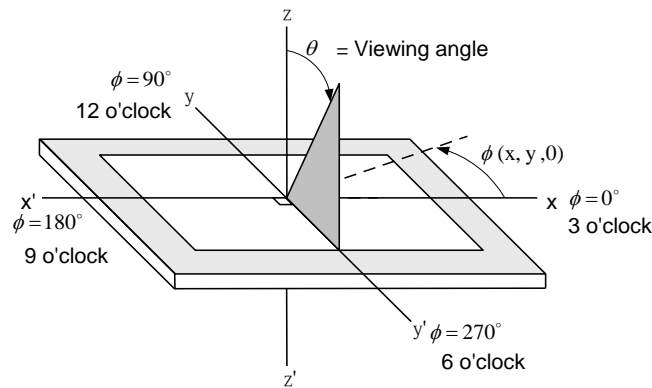
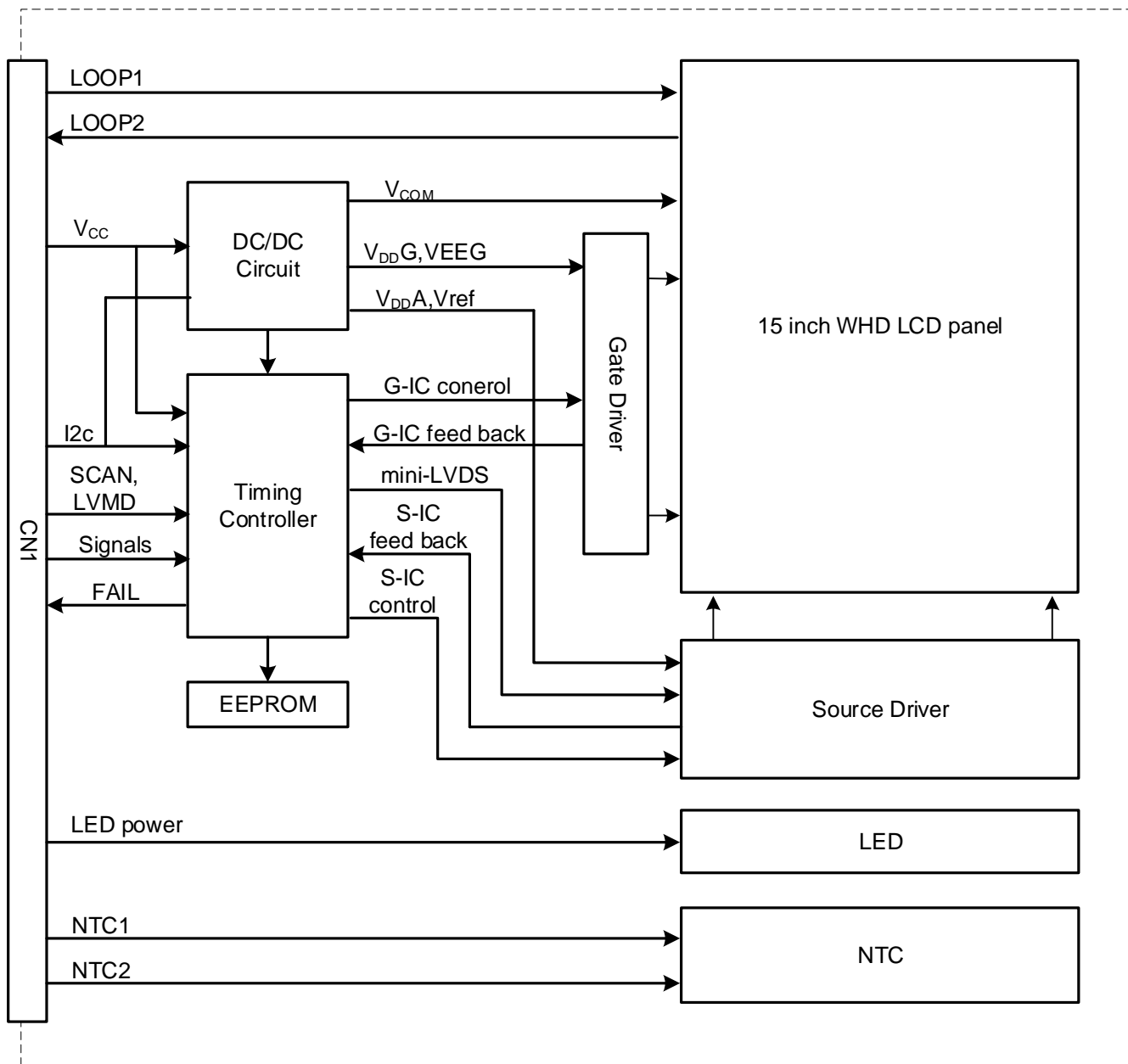

Fig 6.4

Note 6: The color chromaticity is measured from the center point of the panel, P5, as shown in Fig. 6.2.

7. BLOCK DIAGRAM



Note 1: Signals are CLK and pixel data pairs.

8. RELIABILITY TESTS

Test Item	Condition	
High Temperature	1) Operating 2) 85°C	500 hrs
Low Temperature	1) Operating 2) -40°C	500 hrs
High Temperature	1) Storage 2) 90°C	500 hrs
Low Temperature	1) Storage 2) -40°C	500 hrs
Heat Cycle	1) Operating 2) -30°C ~80°C 3) 3hrs~1hr~3hrs	500 hrs
Thermal Shock	1) Non-Operating 2) -35°C ↔ 85°C 3) 0.5 hr ↔ 0.5 hr	500 hrs
High Temperature & Humidity	1) Operating 2) 40°C & 85%RH 3) Without condensation	500 hrs (Note 3)
Vibration	1) Non-Operating 2) 10~200 Hz 3) 5G 4) X, Y, and Z directions	1 hr for each direction
Mechanical Shock	1) Non-Operating 2) 10 ms 3) 80G 4) ±X, ±Y and ±Z directions	Once for each direction
ESD	1) Operating 2) Tip: 150 pF, 330 Ω 3) Air discharge for glass: ± 12KV 4) Contact discharge for metal frame: ± 15KV	1) Glass: 9 points 2) Metal frame: 8 points (Note4)

Note 1: Display functionalities are inspected under the conditions defined in the specification after the reliability tests.

Note 2: The display is not guaranteed for use in corrosive gas environments.

Note 3: Under the condition of high temperature & humidity, if the temperature is higher than 60°C, the humidity needs to be reduced as Fig. 8.1 shown.

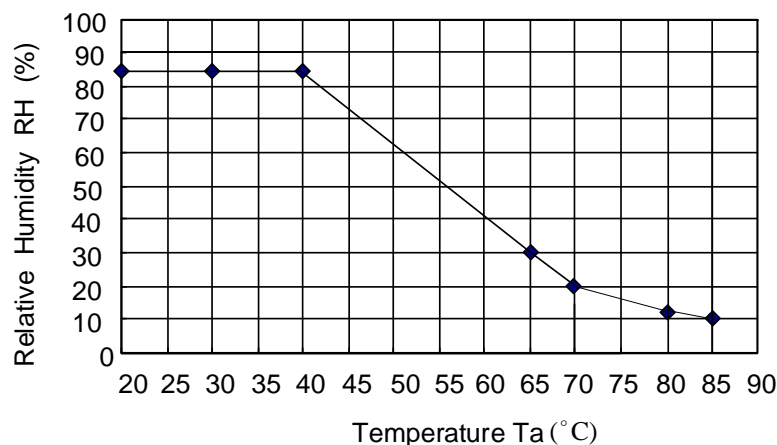

Fig. 8.1

Note 4: All pins of LCD interface (CN1) have been tested by ± 100V contact discharge of ESD under non-operating condition.

9. LCD INTERFACE

9.1 INTERFACE PIN CONNECTIONS

The display interface connector (CN1) is 505110-6091 made by MOLEX and pin assignment is as below:

Pin No.	Symbol	Signal	Pin No.	Symbol	Signal
1	LOOP1	Loop back1 → LOOP2(*2)	31	RX3-	LVDS Data3-
2	V _{CC}	Power Supply (3.3V)	32	GND	Ground
3	V _{CC}	Power Supply (3.3V)	33	RXC+	LVDS Clock+
4	V _{CC}	Power Supply (3.3V)	34	RXC-	LVDS Clock-
5	V _{CC}	Power Supply (3.3V)	35	GND	Ground
6	NC	No connecting	36	RX2+	LVDS Data2+
7	GND	Ground	37	RX2-	LVDS Data2-
8	GND	Ground	38	GND	Ground
9	GND	Ground	39	RX1+	LVDS Data1+
10	GND	Ground	40	RX1-	LVDS Data1-
11	LVMD	Input : LVDS MAP (Low : JEIDA, High : VESA)	41	GND	Ground
12	SCAN	Input : Scan direction (Low : Normal, High : Reverse)	42	RX0+	LVDS Data0+
13	FAIL	Output : Fail detect signal (Normal : High, Fail : Low)	43	RX0-	LVDS Data0-
14	GND	Ground	44	I2C_SCL	I2C (Serial Clock) Internal pull-High
15	Reserved	Keep to V _{CC} level	45	I2C_SDA	I2C (Serial Data) Internal pull-High
16	Reserved	Keep to V _{CC} level	46	LOOP2	Loop back2 → LOOP1(*2)
17	GND	Ground	47	NTC1	Backlight temperature Sensor pin 1 (*4)
18	Reserved	Keep to V _{CC} level	48	NTC2	Backlight temperature Sensor pin 2 (*4)
19	Reserved	Keep to V _{CC} level	49	BL_C6	Backlight cathode 6
20	GND	Ground	50	BL_C5	Backlight cathode 5
21	Reserved	Keep to V _{CC} level	51	BL_C4	Backlight cathode 4
22	Reserved	Keep to V _{CC} level	52	BL_C3	Backlight cathode 3
23	GND	Ground	53	BL_C2	Backlight cathode 2
24	Reserved	Keep to V _{CC} level	54	BL_C1	Backlight cathode 1
25	Reserved	Keep to V _{CC} level	55	NC	No connecting
26	GND	Ground	56	NC	No connecting
27	Reserved	Keep to V _{CC} level	57	NC	No connecting
28	Reserved	Keep to V _{CC} level	58	NC	No connecting
29	GND	Ground	59	BL_A1	Backlight anode1 common (For cathode 1,2,3)
30	RX3+	LVDS Data3+	60	BL_A2	Backlight anode1 common (For cathode 4,5,6)

Note 1: I2C_SCL/I2C_SDA

I2C line is connected to TCON(Timing controller) and PMIC(Power Management IC) with pull-up internal resistor;4.7kΩ on PCB. It is possible to contact the resistor of TCON via I2C. Please do not contact to PMIC.

(a) I2C device address

Parts	Slave address (binary)	Remark
TCON	1100_PPP	PPP: Page Address
PMIC(DCDC)	1000_000	-
PMIC(V _{COM} cal)	1001_111	-

(b) Interface I2C line electrical characteristics

Parameter	Symbol	Min	Typ	Max	Unit
Input voltage ' H ' level of logic	V _{IH}	0.7V _{CC}	-	V _{CC}	V
Input voltage ' L ' level	V _{IL}	GND	-	0.3V _{CC}	V
High Level Output Voltage	V _{OH}	V _{CC} -0.4	-	V _{CC}	V
Low Level Output Voltage	V _{OL}	-	-	0.4	V
Pull Up Resistor	R _{UP}	4.5	4.7	4.9	kΩ
SCL operating frequency	f _{SCL}	10	-	225	kHz
Bus free time between START and STOP condition	t _{BUF}	1200	-	-	ns
START condition hold time	t _{HDSTA}	600	-	-	ns
START condition setup time	t _{SUSTA}	600	-	-	ns
Stop condition setup time	t _{SUSTO}	600	-	-	ns
Data hold time	t _{HDDAT}	0	-	-	ns
Data setup time	t _{SUDAT}	100	-	-	ns
SCL clock low period	t _{LOW}	1200	-	-	ns
SCL clock high period	t _{HIGH}	600	-	-	ns
Clock/data fall time	t _F	-	-	300	ns
Clock/data rise time	t _R	-	-	300	ns

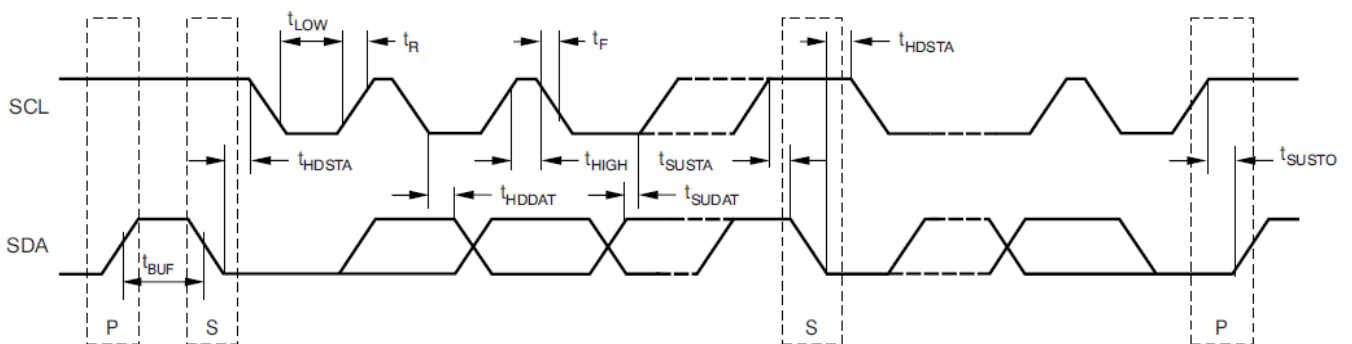

Note 2: LOOP1, LOOP2

The details are shown in section "7. FAILURE DETECTION". Please connect to GND when it is not used.

Note 3: FAIL

The details are shown in section "7. FAILURE DETECTION". Please keep open when it is not used.

Note 4: NTC1, NTC2

Thermistor characteristics (Material : TD05-3H103FR)

Item	Specification	Condition
Resistance	10k ohm \pm 1%	zero-power resistance at 25°C
B-constant	3370K \pm 1%	B-value between 25 to 50°C
Maximum power dissipation	300mW	-
Heat dissipation	2.4mW/°C	at 25°C
Operating temperature range	-40 ~ 150°C	-
Rohs	Compliant	--

Placed in the edge of Backlight close to LED.

Note 5: Please refer to 9.9 SCAN DIRECTION for the setting methods of scan function.

9.2 LVDS INTERFACE

1) VESA Mapping Mode

8Bit Mode (LVMD = H)

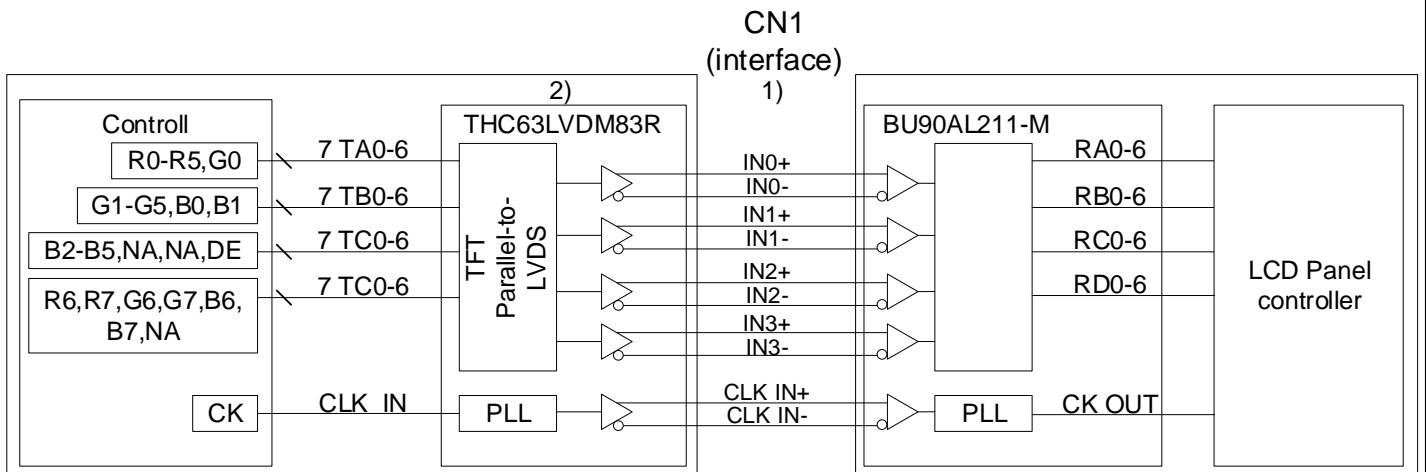

2) JEIDA Mapping Mode

① 8Bit Mode(LVMD = L)

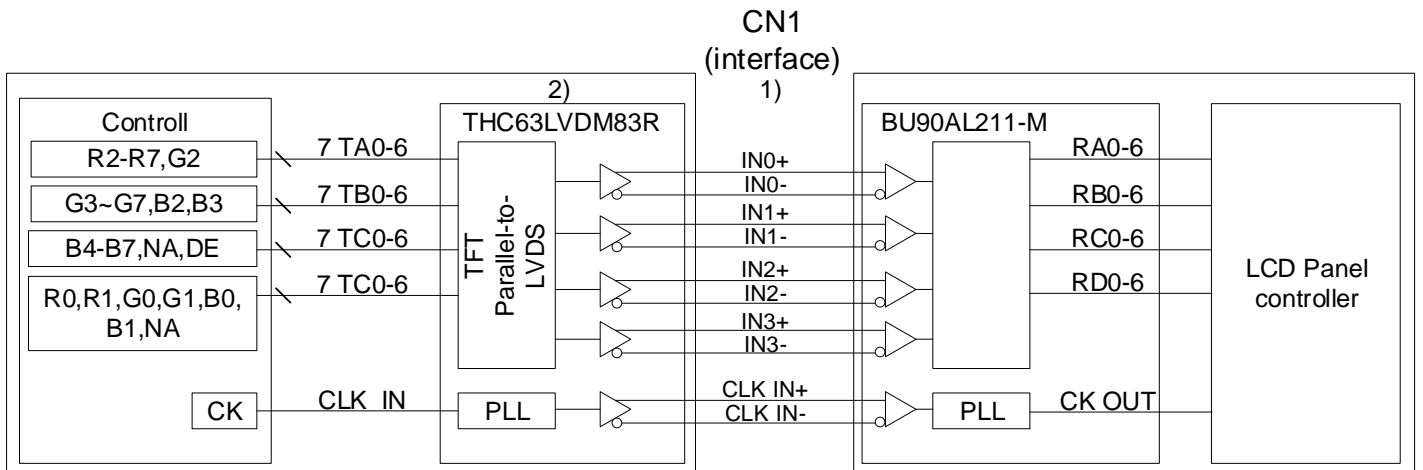

② 6Bit Mode(LVMD = L)

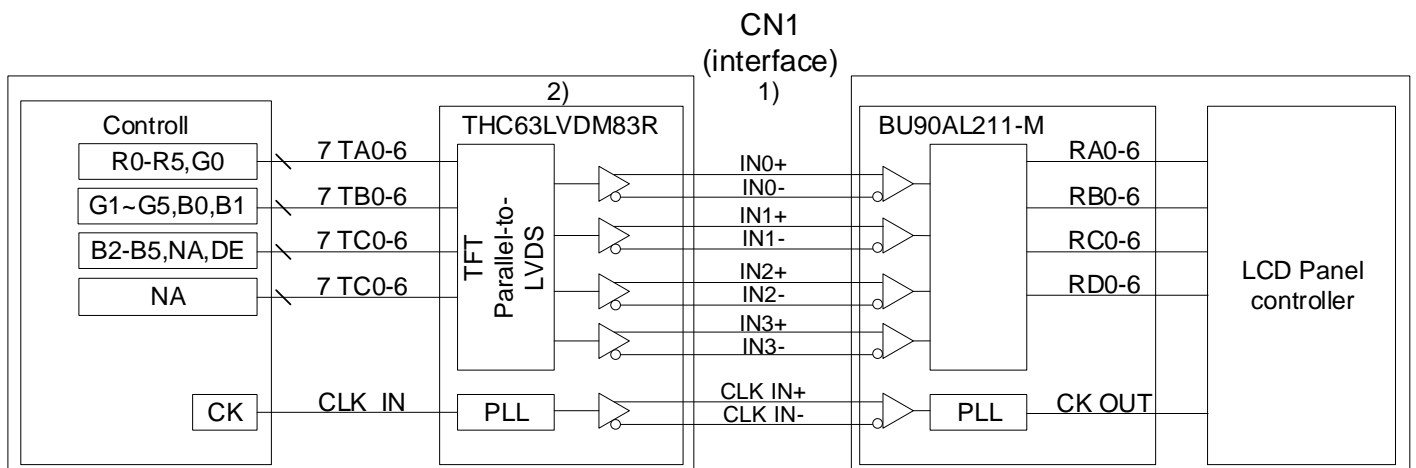

When LVMD is "L" and 6bit input, the following connection is recommended.

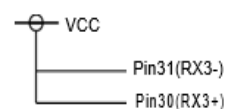

Note 1: Transmitter Made by Thine : THC63LVDM83R or equivalent.

Note 2: 100Ω impedance of LVDS cable is recommended for best optical performance.

9.3 DATA MAPPING

Transmitter		VESA Mode	JEIDA Mode	
		8Bit Mode	8Bit Mode	6Bit Mode
Pin No.	Pin name	LVMD		
		HIGH	LOW	
51	TA0	R0(LSB)	R2	R0(LSB)
52	TA1	R1	R3	R1
54	TA2	R2	R4	R2
55	TA3	R3	R5	R3
56	TA4	R4	R6	R4
3	TA5	R5	R7(MSB)	R5(MSB)
4	TA6	G0(LSB)	G2	G0(LSB)
6	TB0	G1	G3	G1
7	TB1	G2	G4	G2
11	TB2	G3	G5	G3
12	TB3	G4	G6	G4
14	TB4	G5	G7(MSB)	G5(MSB)
15	TB5	B0(LSB)	B2	B0(LSB)
19	TB6	B1	B3	B1
20	TC0	B2	B4	B2
22	TC1	B3	B5	B3
23	TC2	B4	B6	B4
24	TC3	B5	B7(MSB)	B5(MSB)
27	TC4	(NA)	(NA)	(NA)
28	TC5	(NA)	(NA)	(NA)
30	TC6	DE	DE	DE
50	TD0	R6	R0(LSB)	(NA)
2	TD1	R7(MSB)	R1	(NA)
8	TD2	G6	G0(LSB)	(NA)
10	TD3	G7(MSB)	G1	(NA)
16	TD4	B6	B0(LSB)	(NA)
18	TD5	B7(MSB)	B1	(NA)
25	TD6	(NA)	(NA)	(NA)

(1) 8Bit Mode (LVMD=H)

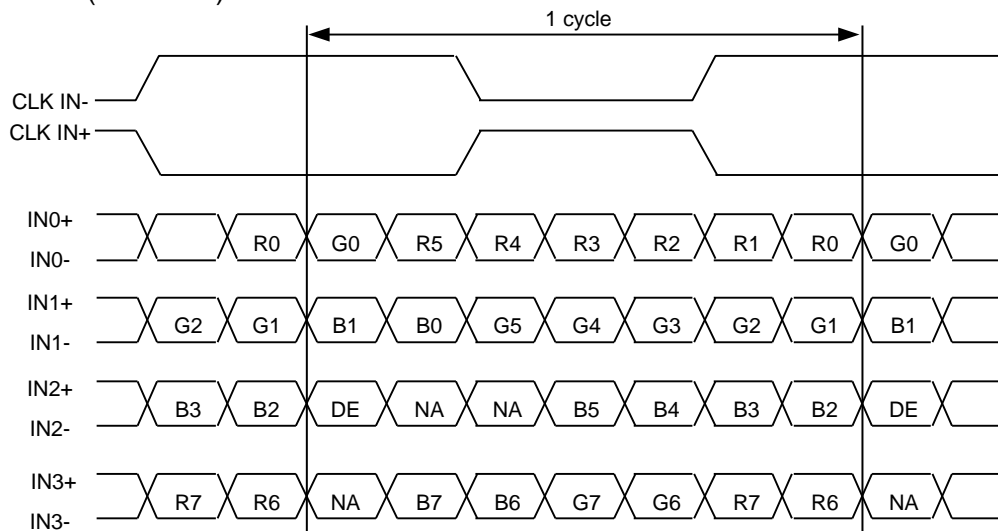

(2) 8Bit Mode (LVMD=L)

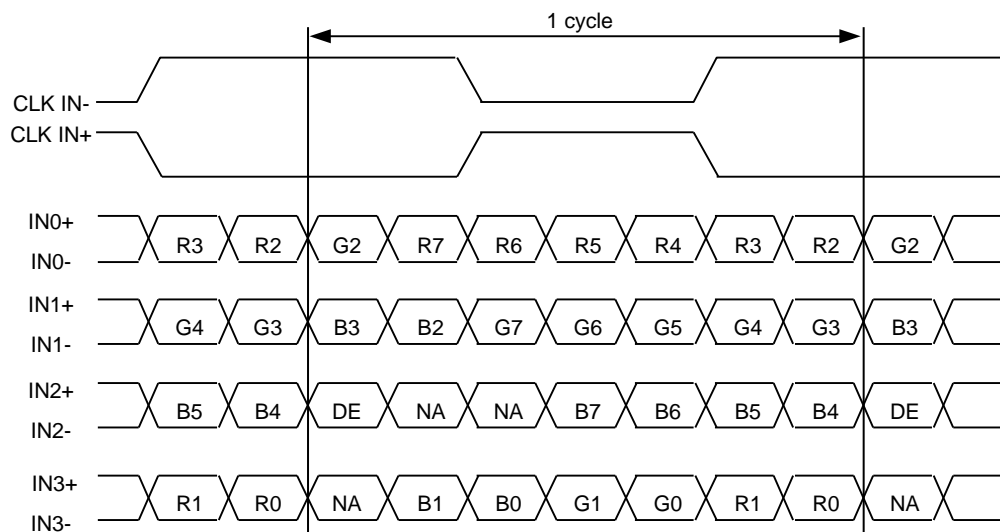

(3) 6Bit Mode (LVMD=L)

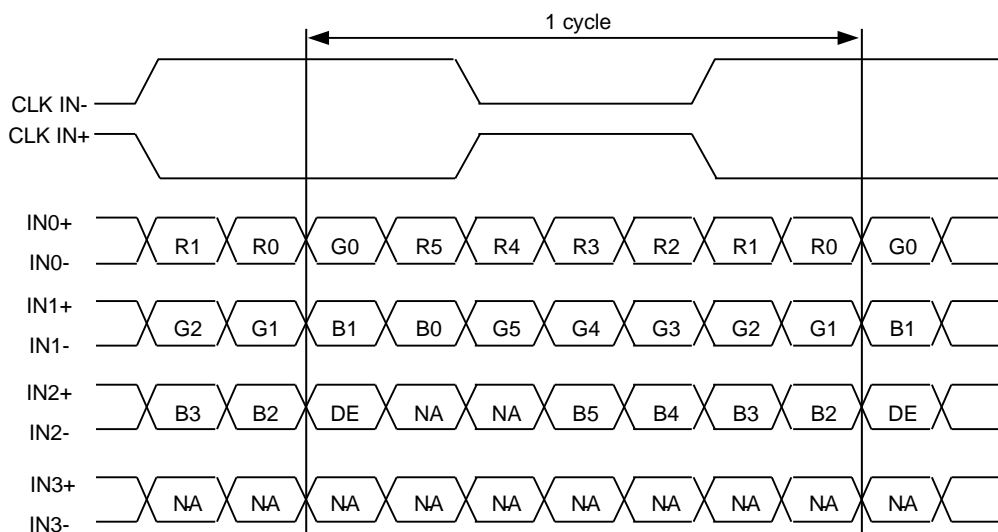

DE : Display Enable
 NA : Not Available

9.4 TIMING CHART

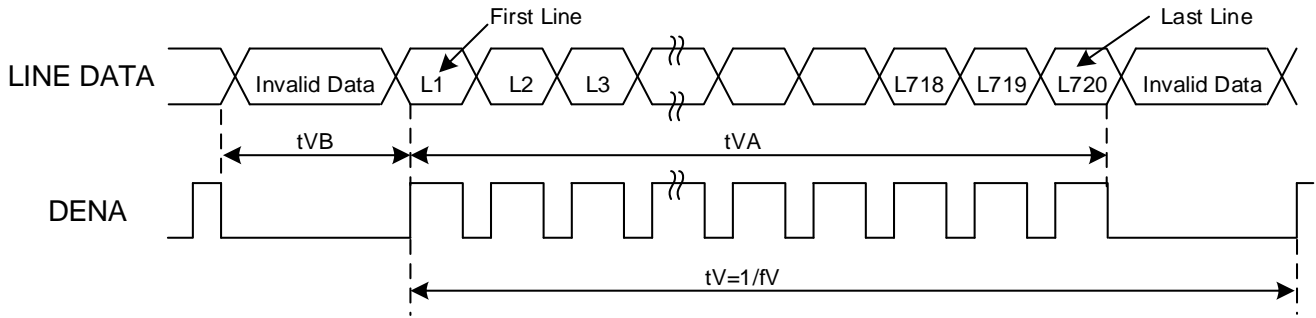

Fig. 9.1 Vertical Time

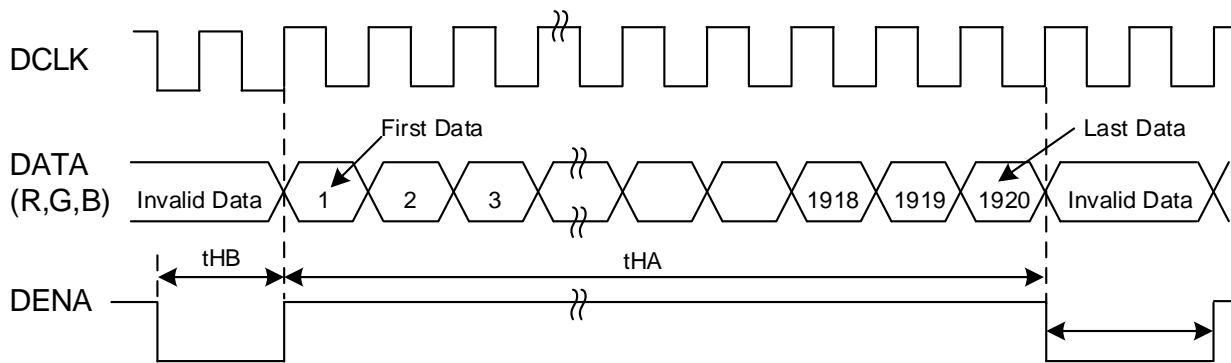

Fig. 9.2 Horizontal Timing

9.5 TIME TABLE

The column of timing sets including minimum, typical, and maximum as below are based on the best optical performance, frame frequency (f_{Frame}) = 60 Hz to define. If 60 Hz is not the aim to set, less than 62 Hz for f_{Frame} is recommended to apply for better performance by other parameter combination as the definitions in section 5.1.

A. Horizontal and Vertical Timing

Item		Symbol	Min.	Typ.	Max.	Unit
Horizontal	CLK Frequency	fclk	85	87.1	104	M Hz
	Display Data	thd	1920			CLK
	Cycle Time	th	1960	1996	2720	
Vertical	Display Data	tvd	720			H
	Cycle Time	tv	725	727	900	

B. Setup and Hold Time

Item		Symbol	Min.	Typ.	Max.	Unit
CLK	Duty	Tcwh	40	50	60	%
	Cycle Time	Tcph	-	30	-	ns
Data	Setup Time	Tdsu	5	-	-	
	Hold Time	Tdhd	5	-	-	
DE	Setup Time	Tesu	5	-	-	
	Hold Time	Tehd	5	-	-	

9.6 LVDS RECEIVER TIMING

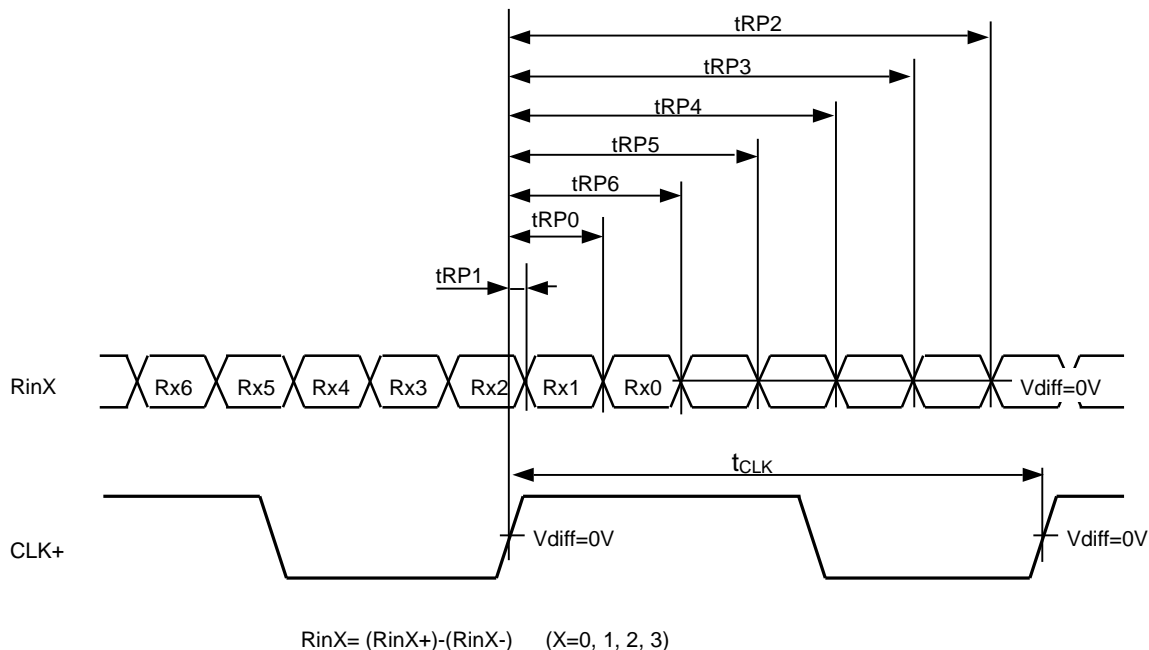

	Item	Symbol	Min.	Typ.	Max.	Unit
CLK	Cycle frequency	$1/t_{CLK}$	85	87.1	104	MHz
RinX (X=0,1,2,3)	0 data position	tRP0	$1/7t_{CLK}-0.65$	$1/7*t_{CLK}$	$1/7t_{CLK}+0.65$	ns
	1st data position	tRP1	-0.65	0	-0.65	
	2nd data position	tRP2	$6/7t_{CLK}-0.65$	$6/7*t_{CLK}$	$6/7t_{CLK}+0.65$	
	3rd data position	tRP3	$5/7t_{CLK}-0.65$	$5/7*t_{CLK}$	$5/7t_{CLK}+0.65$	
	4th data position	tRP4	$4/7t_{CLK}-0.65$	$4/7*t_{CLK}$	$4/7t_{CLK}+0.65$	
	5th data position	tRP5	$3/7t_{CLK}-0.65$	$3/7*t_{CLK}$	$3/7t_{CLK}+0.65$	
	6th data position	tRP6	$2/7t_{CLK}-0.65$	$2/7*t_{CLK}$	$2/7t_{CLK}+0.65$	

9.7 DATA INPUT for DISPLAY COLOR

(8BIT MODE)

Input color		Red Data								Green Data								Blue Data							
		R7	R6	R5	R4	R3	R2	R1	R0	G7	G6	G5	G4	G3	G2	G1	G0	B7	B6	B5	B4	B3	B2	B1	B0
		MSB							LSB	MSB							LSB	MSB							LSB
Basic Color	Black	0	0	0	0	0	0	0	0	0	0	0	0	0	0	0	0	0	0	0	0	0	0	0	
	Red(255)	1	1	1	1	1	1	1	1	0	0	0	0	0	0	0	0	0	0	0	0	0	0	0	
	Green(255)	0	0	0	0	0	0	0	0	1	1	1	1	1	1	1	1	0	0	0	0	0	0	0	
	Blue(255)	0	0	0	0	0	0	0	0	0	0	0	0	0	0	0	1	1	1	1	1	1	1	1	
	Cyan	0	0	0	0	0	0	0	0	1	1	1	1	1	1	1	1	1	1	1	1	1	1	1	
	Magenta	1	1	1	1	1	1	1	1	0	0	0	0	0	0	0	1	1	1	1	1	1	1	1	
	Yellow	1	1	1	1	1	1	1	1	1	1	1	1	1	1	1	0	0	0	0	0	0	0	0	
	White	1	1	1	1	1	1	1	1	1	1	1	1	1	1	1	1	1	1	1	1	1	1	1	
Red	Black	0	0	0	0	0	0	0	0	0	0	0	0	0	0	0	0	0	0	0	0	0	0		
	Red(1)	0	0	0	0	0	0	0	1	0	0	0	0	0	0	0	0	0	0	0	0	0	0		
	Red(2)	0	0	0	0	0	0	1	0	0	0	0	0	0	0	0	0	0	0	0	0	0	0		
	:	:	:	:	:	:	:	:	:	:	:	:	:	:	:	:	:	:	:	:	:	:	:		
	Red(253)	1	1	1	1	1	1	0	1	0	0	0	0	0	0	0	0	0	0	0	0	0	0		
	Red(254)	1	1	1	1	1	1	1	0	0	0	0	0	0	0	0	0	0	0	0	0	0	0		
	Red(255)	1	1	1	1	1	1	1	1	0	0	0	0	0	0	0	0	0	0	0	0	0	0		
Green	Black	0	0	0	0	0	0	0	0	0	0	0	0	0	0	0	0	0	0	0	0	0	0		
	Green(1)	0	0	0	0	0	0	0	0	0	0	0	0	0	0	1	0	0	0	0	0	0	0		
	Green(2)	0	0	0	0	0	0	0	0	0	0	0	0	0	1	0	0	0	0	0	0	0	0		
	:	:	:	:	:	:	:	:	:	:	:	:	:	:	:	:	:	:	:	:	:	:	:		
	Green(253)	0	0	0	0	0	0	0	0	1	1	1	1	1	1	0	1	0	0	0	0	0	0		
	Green(254)	0	0	0	0	0	0	0	0	1	1	1	1	1	1	0	0	0	0	0	0	0	0		
	Green(255)	0	0	0	0	0	0	0	0	1	1	1	1	1	1	1	0	0	0	0	0	0	0		
Blue	Black	0	0	0	0	0	0	0	0	0	0	0	0	0	0	0	0	0	0	0	0	0	0		
	Blue(1)	0	0	0	0	0	0	0	0	0	0	0	0	0	0	0	0	0	0	0	0	0	1		
	Blue(2)	0	0	0	0	0	0	0	0	0	0	0	0	0	0	0	0	0	0	0	0	0	1		
	:	:	:	:	:	:	:	:	:	:	:	:	:	:	:	:	:	:	:	:	:	:	:		
	Blue(253)	0	0	0	0	0	0	0	0	0	0	0	0	0	0	0	1	1	1	1	1	1	0	1	
	Blue(254)	0	0	0	0	0	0	0	0	0	0	0	0	0	0	0	1	1	1	1	1	1	1	0	
	Blue(255)	0	0	0	0	0	0	0	0	0	0	0	0	0	0	0	1	1	1	1	1	1	1	1	

Note 1: Definition of gray scale : Color(n) Number in parenthesis indicates gray scale level. Larger number corresponds to brighter level.

Note 2: Data Signal : 1 : High, 0 : Low

(6BIT MODE)

Input color		Red Data						Green Data						Blue Data					
		R5	R4	R3	R2	R1	R0	G5	G4	G3	G2	G1	G0	B5	B4	B3	B2	B1	B0
		MSB			LSB			MSB			LSB			MSB			LSB		
Basic Color	Black	0	0	0	0	0	0	0	0	0	0	0	0	0	0	0	0	0	0
	Red(63)	1	1	1	1	1	1	0	0	0	0	0	0	0	0	0	0	0	0
	Green(63)	0	0	0	0	0	0	1	1	1	1	1	1	0	0	0	0	0	0
	Blue(63)	0	0	0	0	0	0	0	0	0	0	0	0	1	1	1	1	1	1
	Cyan	0	0	0	0	0	0	1	1	1	1	1	1	1	1	1	1	1	1
	Magenta	1	1	1	1	1	1	0	0	0	0	0	0	1	1	1	1	1	1
	Yellow	1	1	1	1	1	1	1	1	1	1	1	1	0	0	0	0	0	0
	White	1	1	1	1	1	1	1	1	1	1	1	1	1	1	1	1	1	1
Red	Black	0	0	0	0	0	0	0	0	0	0	0	0	0	0	0	0	0	0
	Red(1)	0	0	0	0	0	1	0	0	0	0	0	0	0	0	0	0	0	0
	Red(2)	0	0	0	0	1	0	0	0	0	0	0	0	0	0	0	0	0	0
	:	:	:	:	:	:	:	:	:	:	:	:	:	:	:	:	:	:	:
	Red(61)	1	1	1	1	0	1	0	0	0	0	0	0	0	0	0	0	0	0
	Red(62)	1	1	1	1	1	0	0	0	0	0	0	0	0	0	0	0	0	0
	Red(63)	1	1	1	1	1	1	0	0	0	0	0	0	0	0	0	0	0	0
Green	Black	0	0	0	0	0	0	0	0	0	0	0	0	0	0	0	0	0	0
	Green(1)	0	0	0	0	0	0	0	0	0	0	0	1	0	0	0	0	0	0
	Green(2)	0	0	0	0	0	0	0	0	0	0	1	0	0	0	0	0	0	0
	:	:	:	:	:	:	:	:	:	:	:	:	:	:	:	:	:	:	:
	Green(61)	0	0	0	0	0	0	1	1	1	1	0	1	0	0	0	0	0	0
	Green(62)	0	0	0	0	0	0	1	1	1	1	1	0	0	0	0	0	0	0
	Green(63)	0	0	0	0	0	0	1	1	1	1	1	1	0	0	0	0	0	0
Blue	Black	0	0	0	0	0	0	0	0	0	0	0	0	0	0	0	0	0	0
	Blue(1)	0	0	0	0	0	0	0	0	0	0	0	0	0	0	0	0	0	1
	Blue(2)	0	0	0	0	0	0	0	0	0	0	0	0	0	0	0	0	1	0
	:	:	:	:	:	:	:	:	:	:	:	:	:	:	:	:	:	:	:
	Blue(61)	0	0	0	0	0	0	0	0	0	0	0	0	1	1	1	1	0	1
	Blue(62)	0	0	0	0	0	0	0	0	0	0	0	0	1	1	1	1	1	0
	Blue(63)	0	0	0	0	0	0	0	0	0	0	0	0	1	1	1	1	1	1

Note 1: Definition of gray scale : Color(n) Number in parenthesis indicates gray scale level. Larger number corresponds to brighter level.

Note 2: Data Signal : 1 : High, 0 : Low

9.8 POWER SEQUENCE

Interface signals are also shown in the chart. Signals from any system shall be Hi-resistance state or low level when V_{DD} voltage is off.

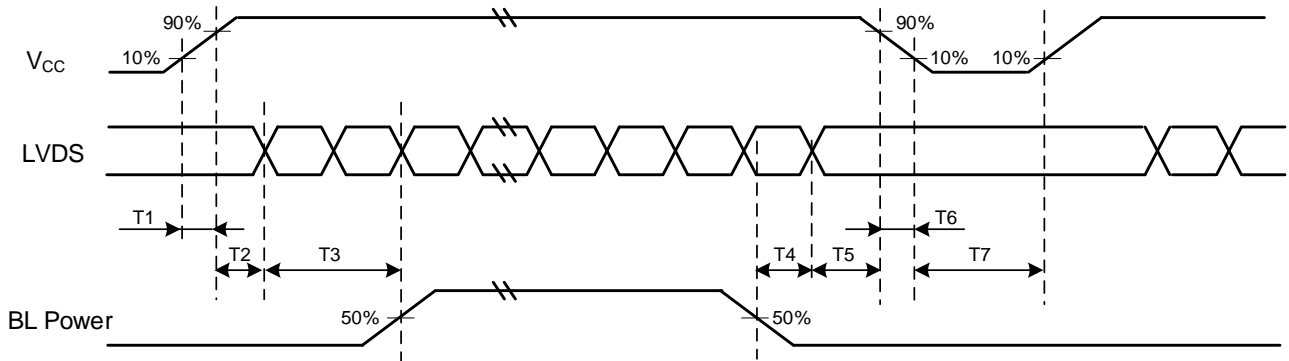

Fig 9.4 Power Sequence

Sequence	Parameter	Symbol	Min.	Max.	Unit
Power ON	VCC rising time	T1	(0.1)	(10)	ms
	VCC 90% to signal	T2	0	--	ms
	signal to Backlight ON (T2<100ms)	T3	(100)	--	ms
Power OFF	Backlight OFF to signal stop	T4	0	--	ms
	signal stop to VCC fall	T5	(60)	--	ms
	VCC falling time	T6	(0.1)	(10)	ms
Restart	restart VCC time	T7	(400)	--	ms

9.9 SCAN DIRECTION

LCD scan direction



SCAN : Low



SCAN : High

10. OUTLINE DIMENSIONS

10.1 FRONT VIEW

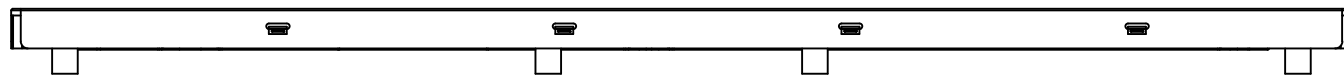
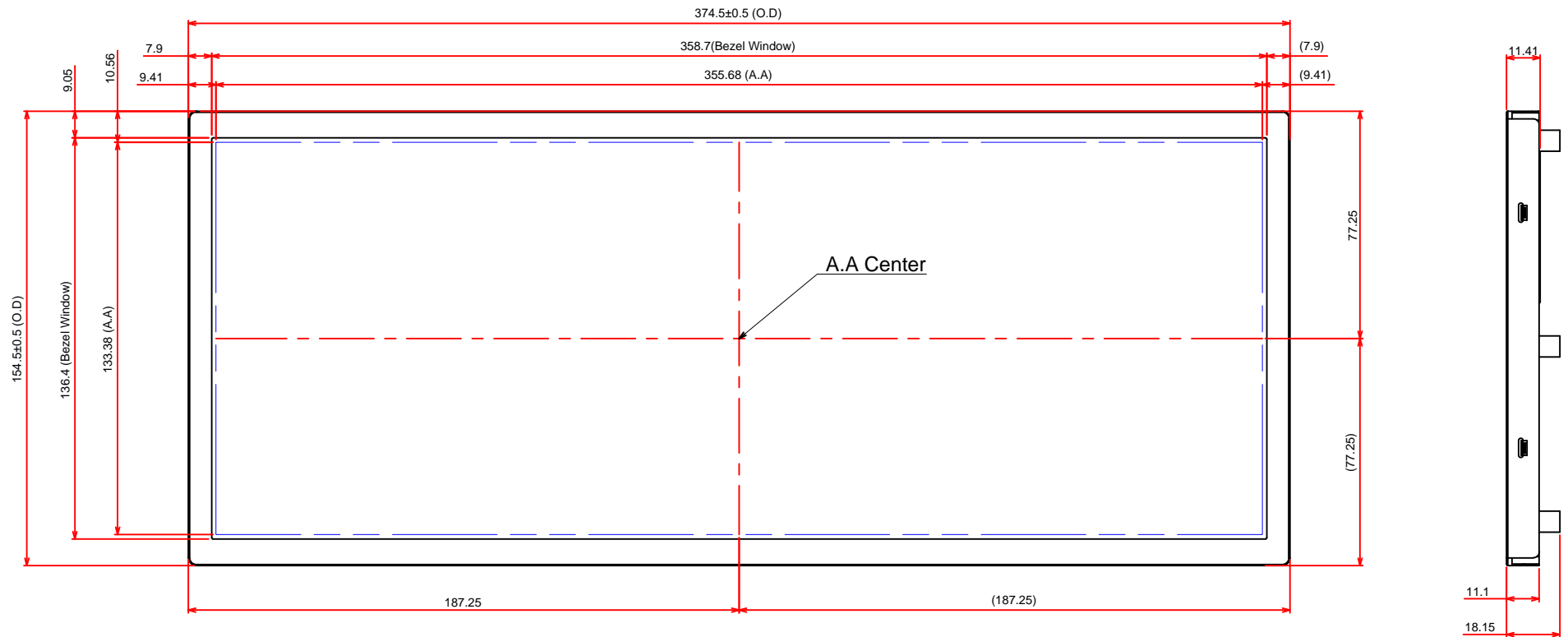

General Tolerance: ± 0.5 mm
Scale : NTS
Unit : mm

10.2 RAER VIEW

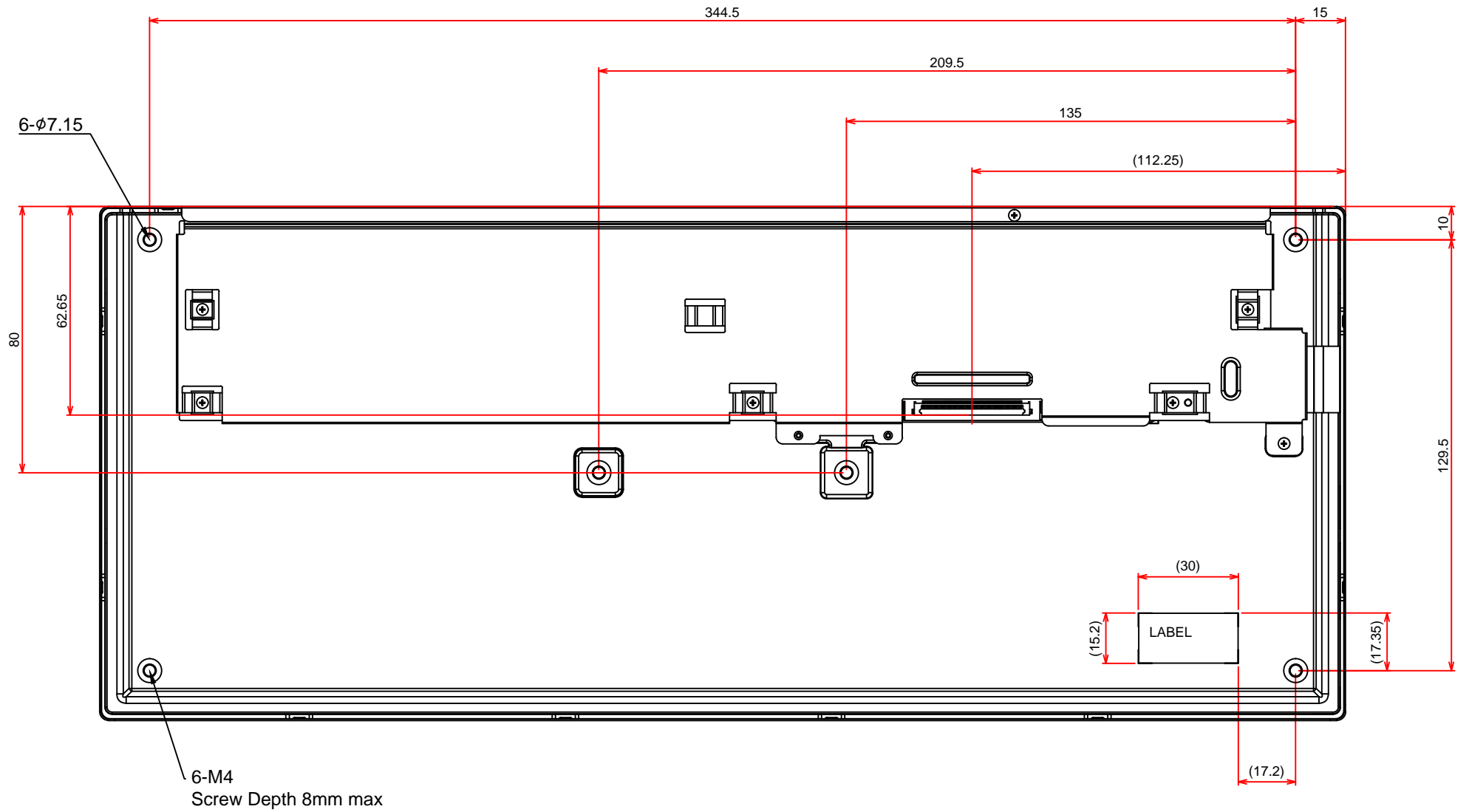

General Tolerance: ±0.5mm
 Scale : NTS
 Unit : mm

DATA MODUL



ALL TECHNOLOGIES. ALL COMPETENCIES. ONE SPECIALIST.



DATA MODUL AG
Landsberger Straße 322
DE-80687 Munich
Phone: +49-89-56017-0

DATA MODUL WEIKERSHEIM GMBH
Lindenstraße 8
DE-97990 Weikersheim
Phone: +49-7934-101-0



More information and worldwide locations can be found at

www.data-modul.com