



SPECIFICATION



ED052TC4

5.17", 720x1280

Version: 2.0

Date: 30.11.2017

Note: This specification is subject to change without prior notice

www.data-modul.com

Version: 2.0

TECHNICAL SPECIFICATION

MODEL NO: ED052TC4

The content of this information is subject to be changed without notice.
Please contact E Ink or its agent for further information.

Customer's Confirmation

Customer _____

Date _____

By _____

E Ink's Confirmation

Approved by 李純慧

Confirmed by 魏鎮祺

Prepared by 魏漢寧

Revision History

Rev.	Issued Date	Revised / Contents
1.0	Aug ,15, 2017	Release
2.0	Nov, 30, 2017	Modify page5 ME drawing, page8 Electrical Characteristic

TECHNICAL SPECIFICATION

CONTENTS

<i>NO.</i>	<i>ITEM</i>	<i>PAGE</i>
-	Cover	1
-	Revision History	2
-	Contents	3
1	General Description	4
2	Features	4
3	Mechanical Specifications	4
4	Mechanical Drawing of Display module	5
5	Input/Output Interface	8
6	Display Module Electrical Characteristics	8
7	Power Sequence	12
8	Optical Characteristics	14
9	Handling, Safety and Environment Requirements And Remark	17
10	Reliability test	17
11	Border definition	18
12	Packing	19

1. General Description

ED052TC4 is a reflective electrophoretic E Ink[®] technology display module based on active matrix TFT substrate. It has 5.17” active area with 720 x 1280 pixels, the display is capable to display images at 2-16 gray levels (1-4 bits) depending on the display controller and the associated waveform file it used.

2. Features

- Carta High contrast reflective/electrophoretic technology
- 720 x 1280 display
- High reflectance
- Ultra wide viewing angle
- Ultra low power consumption
- Pure reflective mode
- Bi-stable
- Commercial temperature range
- Portrait mode

3. Mechanical Specifications

Parameter	Specifications	Unit	Remark
Screen Size	5.17	Inch	
Display Resolution	720 (H)×1280(V)	Pixel	
Active Area	64.44 (H)×114.56 (V)	mm	
Pixel Pitch	89.5 (H) × 89.5 (V)	μm	
Pixel Configuration	Rectangle		
Outline Dimension	69.14 (W) × 124.59 (H) × 0.68 (D)	mm	w/o PF
Module Weight	12.9+/-1.3	g	w/o PF
Number of Gray	16 Gray Level (monochrome)		
Display operating mode	Reflective mode		

4. Mechanical Drawing of Display Module

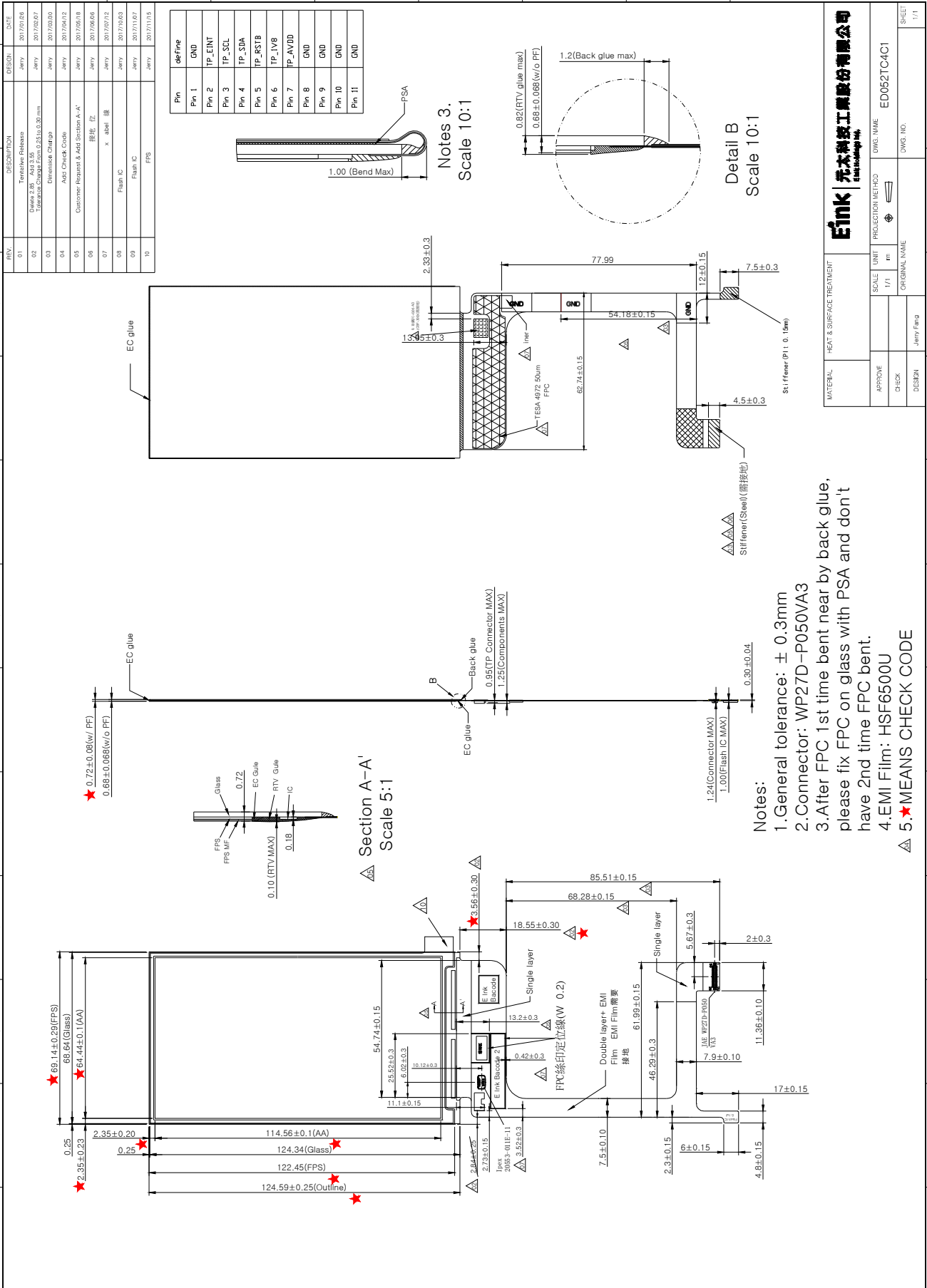

MATERIAL		HEAT & SURFACE TREATMENT	
APPROVE	SCALE	UNIT	PROJECTION METHOD
CHECK	1/1	mm	1:1
DESIGN	ORIGINAL NAME	DWG. NAME	
Jerry Fan	Jerry Fan	ED052TC4C1	
DWG. NO.		SHEET	
1/1		1/1	

E Ink 元太科技工程股份有限公司
E Ink Holdings Inc.

5. Input/output Interface

5-1) Connector type: WP27D-P050VA3

5-2) Pin Assignments

Pin #	Signal	Description	Remark
1	VGH	Positive power supply gate driver	
2	VGH	Positive power supply gate driver	
3	GND	Ground	
4	VCOM	Common connection	
5	VDD_1V8	SPI flash power supply (1.8V)	
6	CKV	Clock gate driver	
7	D0	Data signal source driver	
8	D2	Data signal source driver	
9	D4	Data signal source driver	
10	D6	Data signal source driver	
11	XLE	Latch enable source driver	
12	XCL	Clock source driver	
13	GND	Ground	
14	VDD_3V3	Digital power supply drivers (3.3V)	
15	VDD_3V3	Digital power supply drivers (3.3V)	
16	GND	Ground	
17	VNEG	Negative power supply source driver	
18	VNEG	Negative power supply source driver	
19	GND	Ground	
20	TP_SCL	Reserve for TP	
21	TP_RSTB	Reserve for TP	
22	TP_AVDD	Reserve for TP	
23	GND	Ground	
24	SPI_SDI	Serial Data Input for Flash memory	Note 5-1
25	SPI_SCL	Serial Data Clock for Flash memory	Note 5-1
26	SPI_SDO	Serial Data Output for Flash memory	Note 5-1
27	SPI_NCS	Chip Select for Flash memory	Note 5-1
28	GND	Ground	
29	TP_1V8	Reserve for TP	
30	TP_SDA	Reserve for TP	
31	TP_EINT	Reserve for TP	
32	GND	Ground	
33	VPOS	Positive power supply source driver	
34	VPOS	Positive power supply source driver	
35	GND	Ground	
36	XON	Output enable gate driver	
37	TS	Thermistor sensor	

ED052TC4

38	TS_GND	Thermistor Analog Ground	
39	XOE	Output enable source driver	
40	XSTL	Start pulse source driver	
41	D7	Data signal source driver	
42	D5	Data signal source driver	
43	D3	Data signal source driver	
44	D1	Data signal source driver	
45	SPV	Start pulse gate driver	
46	MODE	Output mode selection gate driver	
47	BORDER	Border connection	
48	GND	Ground	
49	VGL	Negative power supply gate driver	
50	VGL	Negative power supply gate driver	

Note 5-1

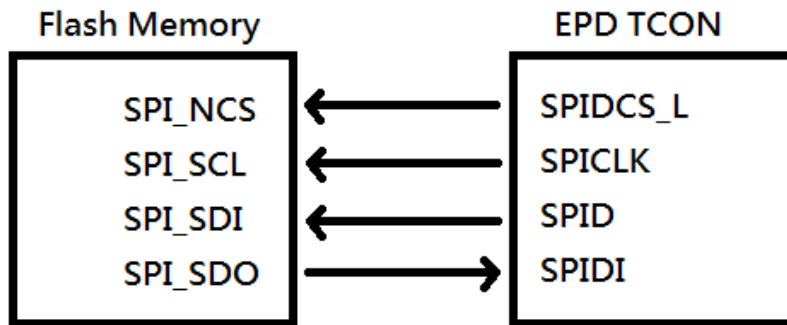

5-3) Panel Scan Direction

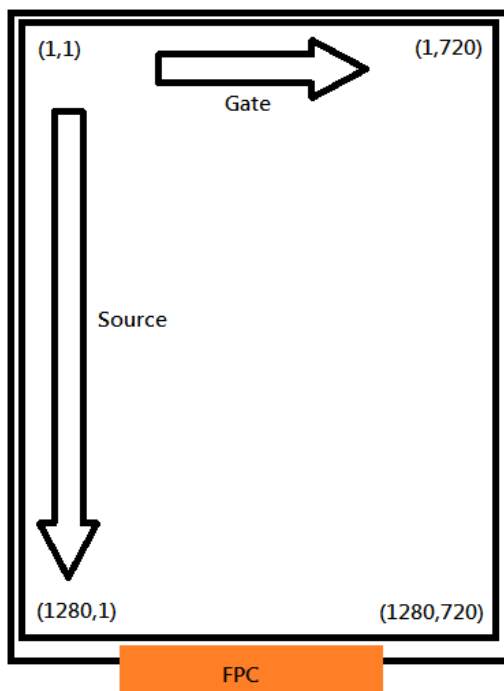

6. Electrical Characteristics

6-1) Absolute Maximum Ratings:

Parameter	Symbol	Rating	Unit	Remark
Logic Supply Voltage	VDD_3V3	-0.3 to 5.0	V	--
Positive Supply Voltage	V _{POS}	-0.3 to +18	V	--
Negative Supply Voltage	V _{NEG}	-18 to +0.3	V	--
Max .Drive Voltage Range	V _{POS} - V _{NEG}	36	V	--
Supply Voltage	VGH	-0.3 to VGL+50	V	--
Supply Voltage	VGL	-25 to +0.3	V	--
Supply Range	VGH-VGL	10 to 45	V	--
Operating Temp. Range	TOTR	-30 to +85		--
Storage Temperature	TSTG	-55 to +125		--

6-2) Panel DC Characteristics

Parameter	Symbol	Conditions	Min	Typ	Max	Unit
Signal ground	V _{SS}		-	0	-	V
Logic Voltage supply	V _{DD_3V3}		3.0	3.3	3.6	V
	I _{VDD_3V3}	V _{DD} =3.3V	-	5	9	mA
SPI Voltage supply	V _{DD_1V8}		1.65	1.8	1.95	V
	I _{VDD_1V8}	V _{DD_1V8} =1.8V	-		1.5	mA
Gate Negative supply	VGL		-21	-20	-19	V
	I _{GL}	VGL=-20V	-	1	6	mA
Gate Positive supply	VGH		21	22	23	V
	I _{GH}	VGH=22V	-	0.5	1	mA
Source Negative supply	V _{NEG}		-15.4	-15	-14.6	V
	I _{NEG}	V _{NEG} =-15V	-	1.3	29	mA
Source Positive supply	V _{POS}		14.6	15	15.4	V
	I _{POS}	V _{POS} =15V	-	1.2	38	mA
Border supply	V _{COM}		-5.0	Adjusted	-2.0	v
Asymmetry source	V _{Asym}	V _{POS} + V _{NEG}	-800	0	800	mV
Common voltage	V _{COM}		-3.05	Adjusted	-0.5	V
	I _{COM}		-	0.2	-	mA
Panel Power	P		-	85	1177	mW
Standby power panel	P _{STBY}		-	-	0.4	mW
Operating temperature			0	-	50	°C
Storage temperature			-25	-	70	°C

- The maximum power consumption is measured using 85 Hz waveform with following pattern transition: from pattern of repeated 1 consecutive black scan lines followed by 1 consecutive white scan line to that of repeated 1 consecutive white scan lines followed by 1 consecutive black scan lines. (Note 6-1)
- The Typical power consumption is measured using 85 Hz waveform with following pattern transition: from horizontal 4 gray scale pattern to vertical 4 gray scale pattern. (Note 6-2)
- The standby power is the consumed power when the panel controller is in standby mode.
- The listed electrical/optical characteristics are only guaranteed under the controller & waveform provided by E Ink.
- Vcom is recommended to be set in the range of assigned value ± 0.1 V
- The maximum I_{COM} inrush current is about 600 mA

Note6-1

The maximum power consumption

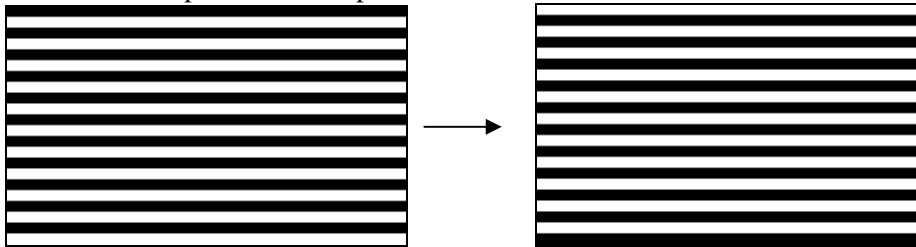

Note6-2

The typical power consumption

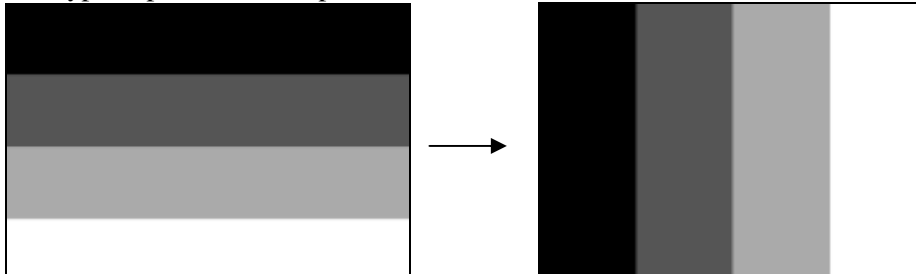

6-4) Refresh Rate

The module ED052TC4 is applied at a maximum refresh rate of 85 Hz.

	Min	Max
Refresh Rate	-	85 Hz

6-5) Panel AC characteristics

Parameter	Symbol	Min.	Typ.	Max.	Unit
Clock frequency	fckv			200	kHz
Minimum “L” clock pulse width	twL	0.5			us
Minimum “H” clock pulse width	twH	0.5			us
Clock rise time	trckv			100	ns
Clock fall time	tfckv			100	ns
SPV setup time	tSU	100		twH-100	ns
SPV hold time	tH	100		twH-100	ns
Pulse rise time	trspv			100	ns
Pulse fall time	tfspv			100	ns
Clock XCL cycle time	tcy	16.67	50		ns
D0 .. D7 setup time	tsu	8			ns
D0 .. D7 hold time	th	8			ns
XSTL setup time	tstls	0.5*tcy		0.8*tcy	ns
XSTL hold time	tstlh	0.5*tcy		240*tcy-tstls	ns
XLE on delay time	tLEdly	3.5*tcy			ns
XLE high-level pulse width (When VDD=1.7V to 2.1V)	tLEw	300			ns
XLE off delay time	tLEoff	200			ns
Output setting time to +/- 30mV(C _{load} =200pF)	tout			20	us

OUTPUT LATCH CONTROL SIGNALS

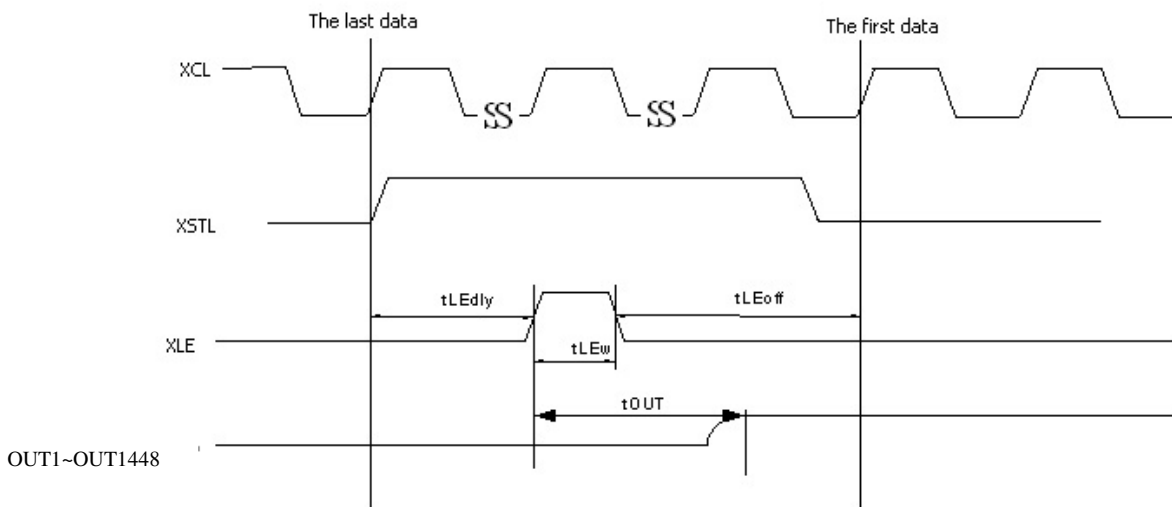

CLOCK & DATA TIMING

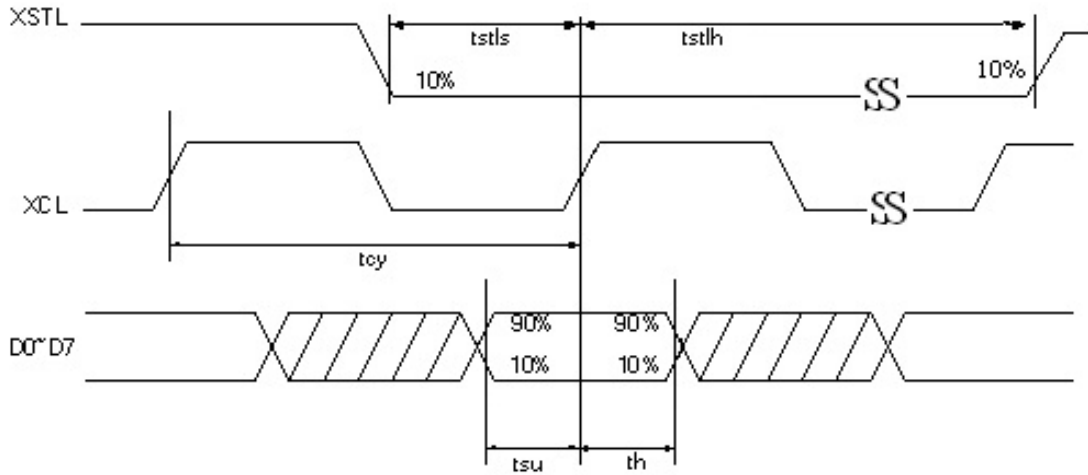

CKV & SPV TIMING

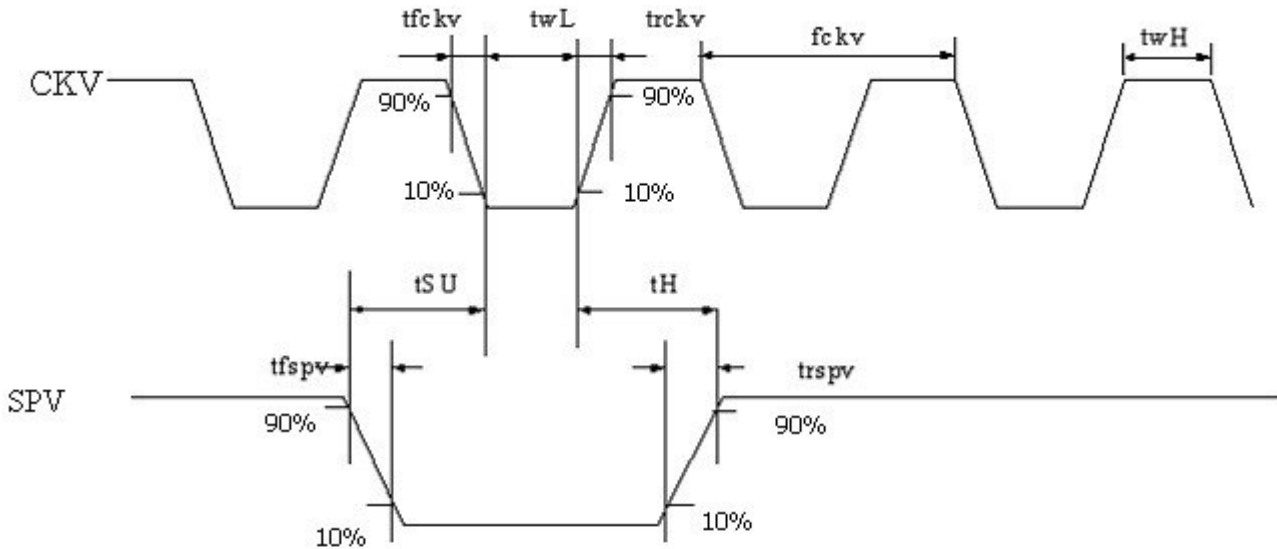

GATE OUTPUT TIMING

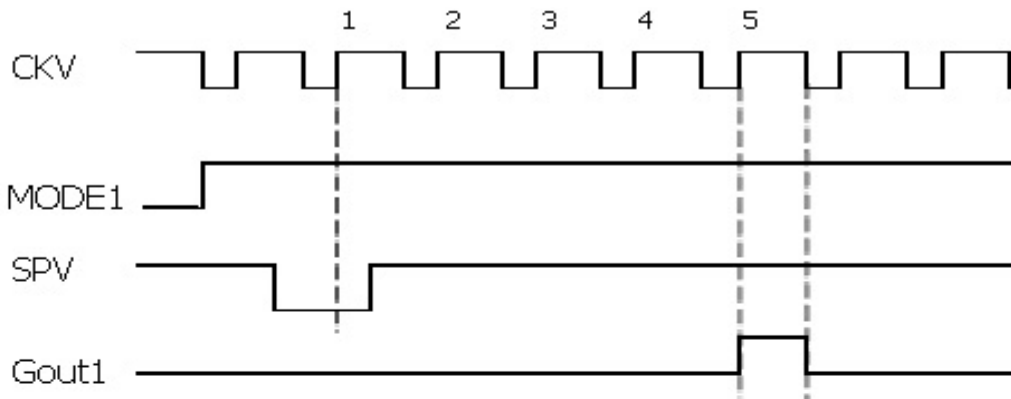

Note First gate line on timing after 5CKV gate line is on

7. Power Sequence

Power Rails must be sequenced in the following order

1. VSS → VDD → VNEG → VPOS (Source driver) → VCOM
2. VSS → VDD → VGL → VGH (Gate driver)

POWER ON

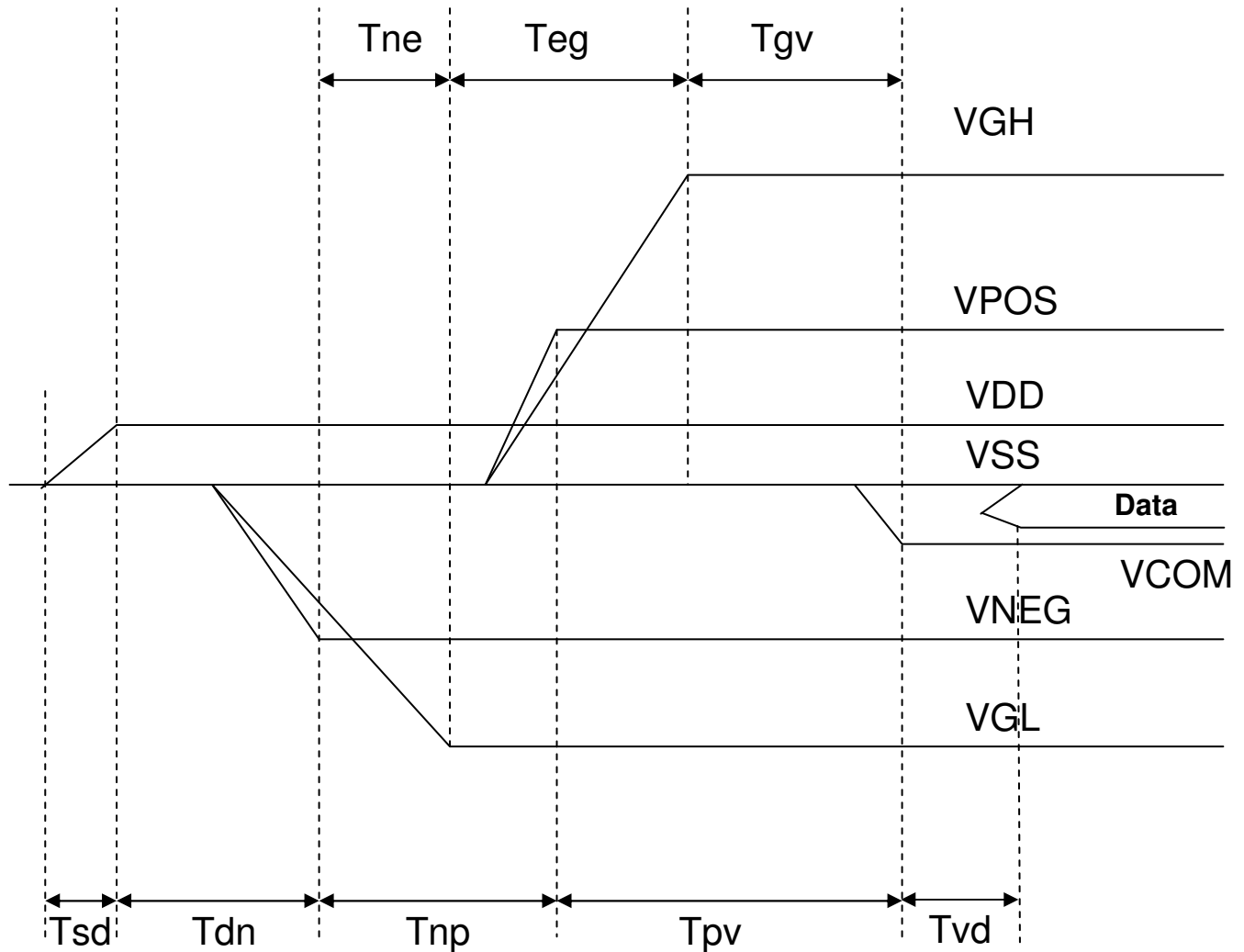

	Min	Max
T_{sd}	30us	-
T_{dn}	100us	-
T_{np}	1000us	-
T_{pv}	100us	-
T_{vd}	100us	-
T_{ne}	0us	-
T_{eg}	1000us	-
T_{gv}	100us	-

POWER OFF

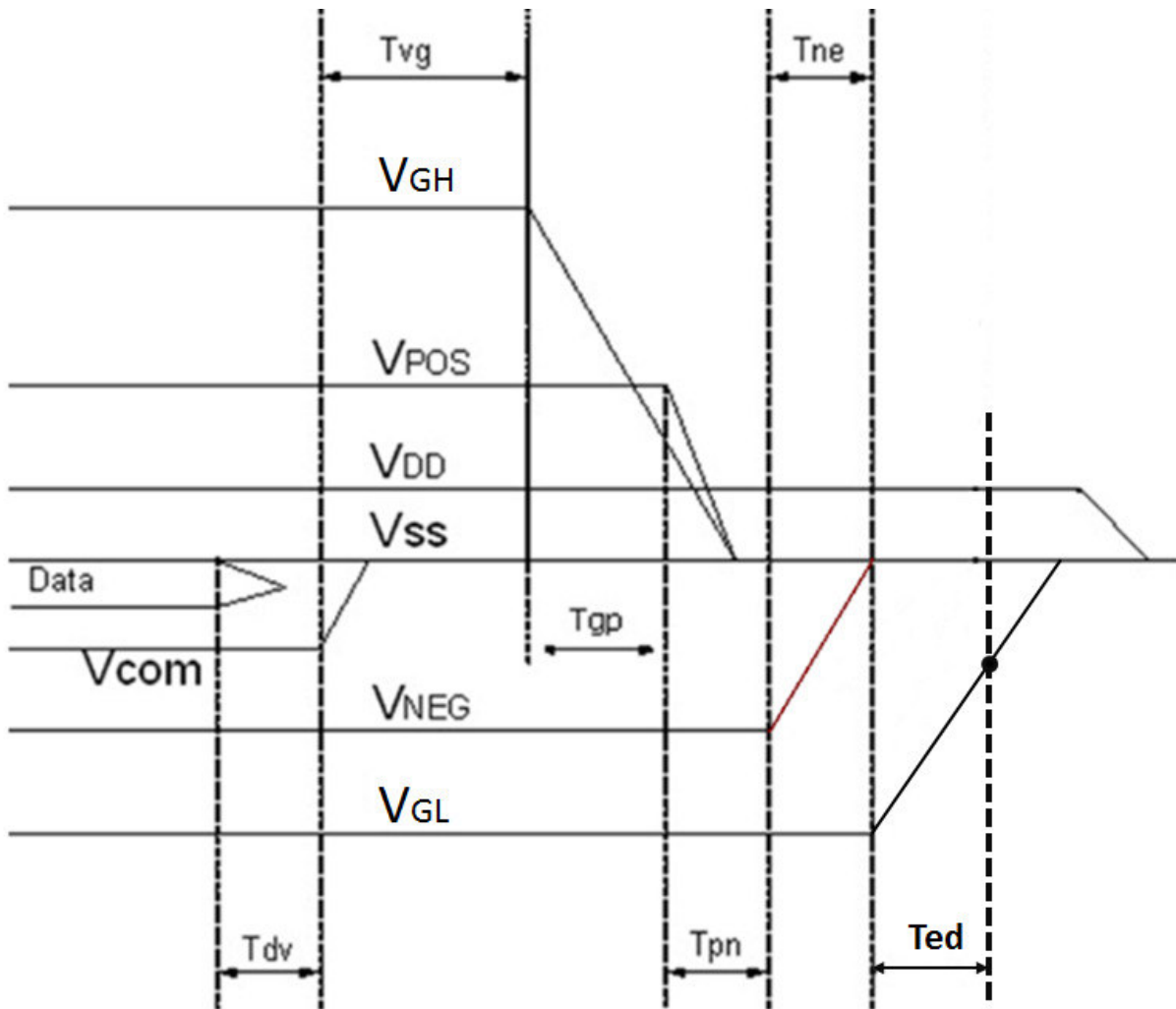

	Min	Max	Remark
Tdv	100μs	-	-
Tvg	0μs	-	-
Tgp	0μs	-	-
Tpn	0μs	-	-
Tne	0μs	-	-
Ted	0.5s	-	Discharged point @ -7.4 Volt

Note 7-1 Supply voltages decay through pull-down resistors.

Note 7-2 : Begin to turn off VGL power after VNEG and VPOS are completely or almost discharged to GND state.

Note 7-3 VGL must remain negative of Vcom during decay period

8. Optical characteristic

8-1) Specification

Measurements are made with that the illumination is under an angle of 45 degrees, the detector is perpendicular unless otherwise specified.

T = 25°C

Symbol	Parameter	Conditions	Min	Typ.	Max	Unit	Note
R	Reflectance	White	38	45	-	%	Note 8-1
Gn	N _{th} Grey Level	-	-	DS+(WS-DS) xn/(m-1)	-	L*	-
CR	Contrast Ratio	-	12	16	-		-

WS: White state , DS: Dark state, Gray state from Dark to White :DS G1 G2... Gn... Gm-2 WS
m:4 8 16 when 2 3 4 bits mode

Note 8-1: Luminance meter: Eye – One Pro Spectrophotometer

8-2) Definition of contrast ratio

The contrast ratio (CR) is the ratio between the reflectance in a full white area (Rl) and the reflectance in a dark area (Rd): CR = Rl / Rd

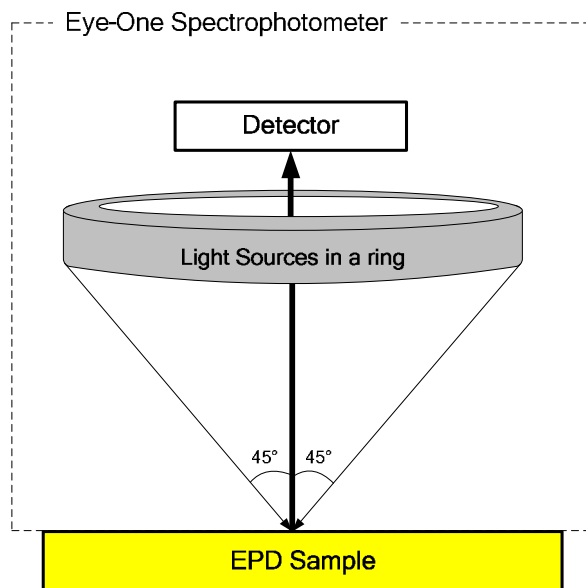

8-3) Reflection Ratio

The reflection ratio is expressed as:

$$R = \text{Reflectance Factor}_{\text{white board}} \times (L_{\text{center}} / L_{\text{white board}})$$

L_{center} is the luminance measured at center in a white area (R=G=B=1). L_{white board} is the luminance of a standard white board.

9. Handling, Safety and Environment Requirements and Remark

WARNING

The display glass may break when it is dropped or bumped on a hard surface. Handle with care. Should the display break, do not touch the electrophoretic material. In case of contact with electrophoretic material, wash with water and soap.

REMARK

All The specifications listed in this document are guaranteed for module only. Post-assembled operation or component(s) may impact module performance or cause unexpected effect or damage and therefore listed specifications is not warranted after any Post-assembled operation.

CAUTION

The display module should not be exposed to harmful gases, such as acid and alkali gases, which corrode electronic components.

Disassembling the display module can cause permanent damage and invalidate the warranty agreements.

IPA solvent can only be applied on active area and the back of a glass. For the rest part, it is not allowed.

Mounting Precautions

(1) It's recommended that you consider the mounting structure so that uneven force (ex. Twisted stress) is not applied to the module.

(2) It's recommended that you attach a transparent protective plate to the surface in order to protect the EPD. Transparent protective plate should have sufficient strength in order to resist external force.

(3) You should adopt radiation structure to satisfy the temperature specification.

(4) Acetic acid type and chlorine type materials for the cover case are not desirable because the former generates corrosive gas of attacking the PS at high temperature and the latter causes circuit break by electro-chemical reaction.

(5) Do not touch, push or rub the exposed PS with glass, tweezers or anything harder than HB pencil lead. And please do not rub with dust clothes with chemical treatment. Do not touch the surface of PS for bare hand or greasy cloth. (Some cosmetics deteriorate the PS)

(6) When the surface becomes dusty, please wipe gently with absorbent cotton or other soft materials like chamois soaks with petroleum benzene. Normal-hexane is recommended for cleaning the adhesives used to attach the PS. Do not use acetone, toluene and alcohol because they cause chemical damage to the PS.

(7) Wipe off saliva or water drops as soon as possible. Their long time contact with PS causes deformations and color fading.

Data sheet status

Product specification	This data sheet contains formal product specifications.
-----------------------	---

Limiting values

Limiting values given are in accordance with the Absolute Maximum Rating System (IEC 134). Stress above one or more of the limiting values may cause permanent damage to the device. These are stress ratings only and operation of the device at these or at any other conditions above those given in the Characteristics sections of the specification is not implied. Exposure to limiting values for extended periods may affect device reliability.

Application information

Where application information is given, it is advisory and does not form part of the specification.

10. Reliability test

	TEST	CONDITION	METHOD
1	High-Temperature Operation	T = +50°C, RH = 30% , for 240 hrs	IEC 60 068-2-2Bp
2	Low-Temperature Operation	T = 0°C , for 240 hrs	IEC 60 068-2-2Ab
3	High-Temperature Storage	T = +70°C, RH=40% , for 240 hrs (Test In White Pattern)	IEC 60 068-2-2Bp
4	Low-Temperature Storage	T = -25°C , for 240 hrs (Test In White Pattern)	IEC 60 068-2-1Ab
5	High-Temperature, High-Humidity Operation	T = +40°C, RH = 90% , for 168 hrs	IEC 60 068-2-3CA
6	High Temperature, High- Humidity Storage	T = +60 , RH=80% , for 240 hrs (Test In White Pattern)	IEC 60 068-2-3CA
7	Temperature Cycle	-25 +70 , 100 Cycles 30min 30min Test in white pattern	IEC 60 068-2-14
8	Solar radiation test	765 W/m ² , 40 , for 168 hrs (Test In White Pattern)	IEC60 068-2-5Sa
9	Package Vibration	1.04G, Frequency: 10~500Hz Direction: X,Y,Z Duration: 1 hours in each direction	Full packed for shipment
10	Package Drop Impact	Drop from height of 122 cm on concrete surface. Drop sequence: 1 corner, 3 edges, 6 faces One drop for each.	Full packed for shipment
11	Electrostatic Effect (non-operating)	(Machine model)+/- 250V 0 , 200pF	IEC 62179, IEC 62180
12	Stylus Tapping	D 8 mm rubber pen, Load:300gf , Speed: 30times/min , Total: 13,500times	

Actual EMC level to be measured on customer application

Note: The protective film must be removed before temperature test.

< Criteria >

In the standard conditions, there is not display function NG issue occurred. (including: line defect ,no image). All the cosmetic specification is judged before the reliability stress.

11. Border definition

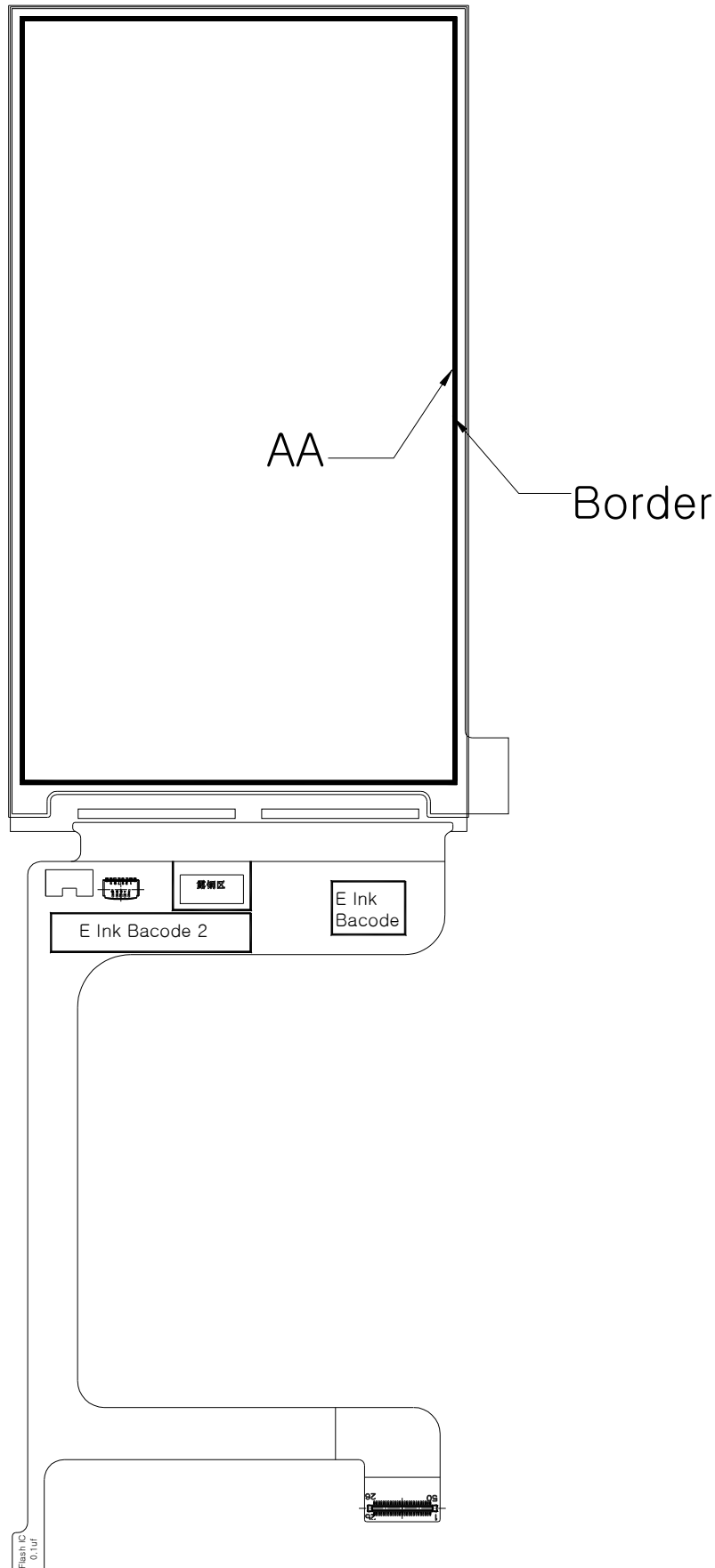

12. Packing

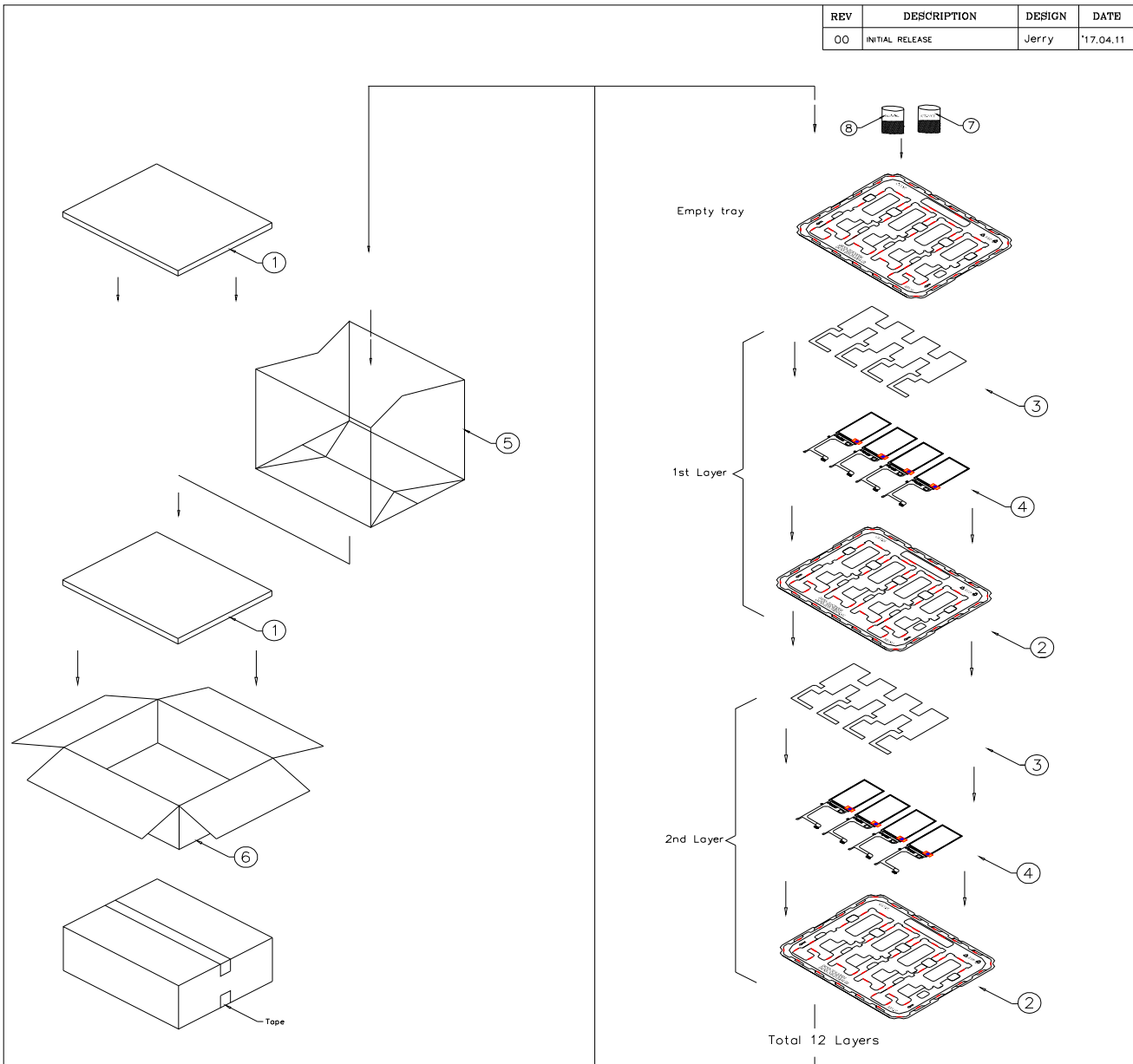

REV	DESCRIPTION	DESIGN	DATE
00	INITIAL RELEASE	Jerry	'17.04.11

NOTE:

- One layer include: 1 piece of cushion sheet, 4 pcs module & 1 piece of tray.
- Q'TY: 48 pcs panel/carton.
- Dimension: 445*365*190mm

8	30g加厚複合紙(含碳粉)規格73*95mm	2	
7	防鐵筒(保潔容積25L)	3	
6	CARTON INTERNAL	1	
5	摺口袋450*380*580mm	1	抗靜電
4	ED052TC4	48	
3	EPE CUSHION SHEET	12	抗靜電
2	TRAY	13	抗靜電
1	EPE FOAM	2	
ITEM	DESCRIPTION	QTY	REMARK

MTL.SPBC.		UNSPECIFIED TOL'S ±5.0mm		REMARK				
		ANGLE						
		ROUGHNESS						
APPROVE	Patrick Lin	'17.04.11	SCALE	UNIT	SHEET	DWG.TITLE		
CHECK	Patrick Lin	'17.04.11	1:1	mm	1 OF 1			
DESIGN	Jerry Fang	'17.04.11	MTL.NO.			DWG.NO.	REV. 01	A4 SIZE



ALL TECHNOLOGIES. ALL COMPETENCIES. ONE SPECIALIST.



DATA MODUL AG
Landsberger Straße 322
DE-80687 Munich
Phone: +49-89-56017-0

DATA MODUL WEIKERSHEIM GMBH
Lindenstraße 8
DE-97990 Weikersheim
Phone: +49-7934-101-0



More information and worldwide locations can be found at

www.data-modul.com