

eDM-COMB-SL6

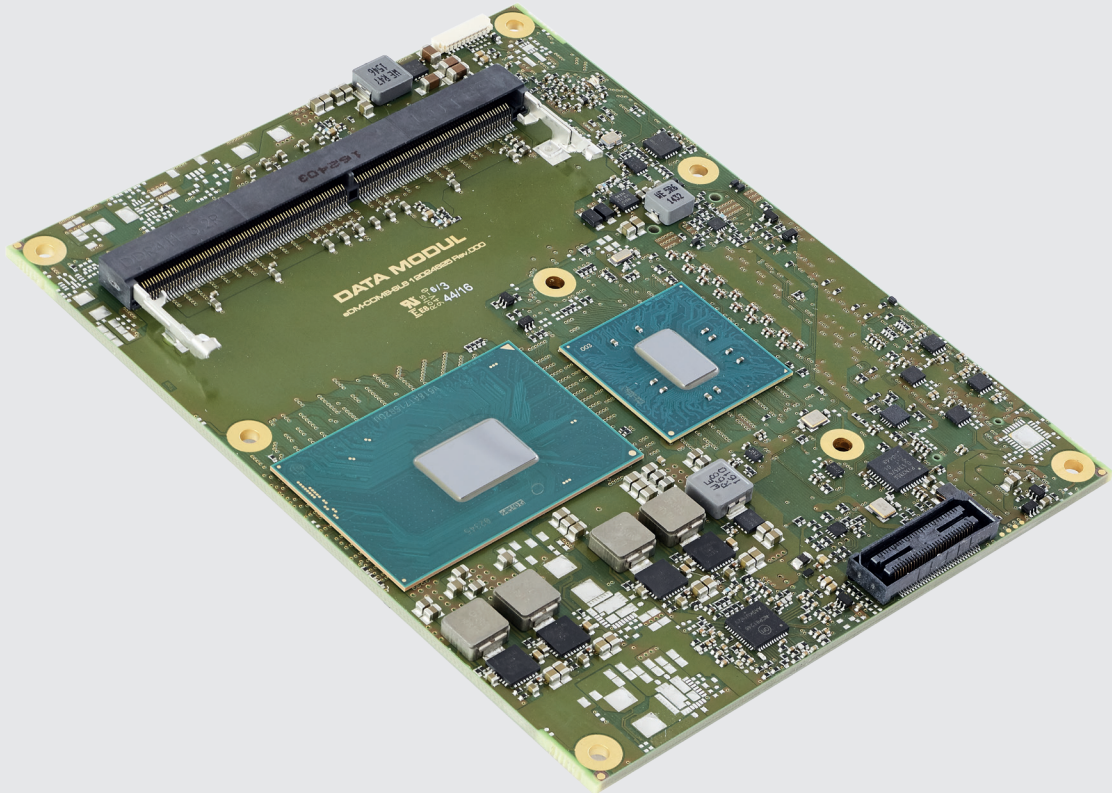

Revision History

Revision	Revision History	Date
00	First release	

Reference to this Specification

The purpose of all the figures and illustrations in this Specification is merely to provide a better explanation and can differ to the actual appearance of the board. They are to be understood as schematic representations.

© Copyright 2016 by DATA MODUL AG

Trademarks:

Microsoft and Windows are registered trademarks of Microsoft Corporation.

HDMI, the HDMI logo and High-Definition Multimedia Interface are trademarks or registered trademarks of HDMI Licensing LLC.

Other trademarks are the property of their respective owners.

Technical and optical changes as well as misprints reserved.

[12025533 Rev. 00]

Contents

Preface	2
About this Specification	2
Danger Symbols and Levels	2
General Symbols	2
Certification	2
Disclaimer	2
Warranty	2
Technical Support	2
COM Express Specification Reference	3
Terminology	3
Specifications	4
Supported Operating Systems	4
Customized UEFI	4
Tools	4
Standards & Certifications	4
Block Diagram	5
Ordering Information	5
Platform Features	5
Additional Interfaces & Functions	7
Environmental Specification	8
Power Supply	8
COM Express Connectors & Signal Descriptions	10
Connector Location	10
General Signal Description	10
COM Express Connector Pinouts	10
Mechanical Specification	22
PCB Dimensions	22
Cooling Solution	22
Assembly Heatspreader Dimensions	22
Mechanical & Thermal Considerations	23
BIOS Setup	24
Terms & Abbreviations	24
BIOS Update Description	25
BIOS Setup Description	25
Main	26
Advanced	28
Chipset	65
Security	76
Boot	80
Save & Exit	82

Preface



About this Specification

This Specification contains information about the hardware components, features and BIOS setup of the eDM-COMB-SL6. The Specification is intended for technically qualified personnel.

Danger Symbols and Levels

In this Specification, symbols are used to highlight important safety instructions and any advice relating to the device. The instructions should be followed very carefully to avoid any risk of accident, personal injury or property damage.

Danger Symbols



	Hazard point
	All DATA MODUL AG products are electrostatic sensitive devices and are packaged accordingly. Do not open or handle a DATA MODUL AG product except at an electrostatic-free workstation. Additionally, do not ship or store DATA MODUL AG products near strong electrostatic, electromagnetic, magnetic, or radioactive fields unless the device is contained within its original manufacturer's packaging. Be aware that failure to comply with these guidelines will void the DATA MODUL AG Limited Warranty.

Danger Levels

CAUTION	Indicates a hazardous situation which, if not avoided, may result in minor or moderate injury.
NOTICE	Indicates a property damage message.

General Symbols

Notes that are marked with these symbols contain important or useful information for the operation respectively the handling of the device.

	Additional support or useful information.
	The crossed-out refuse bin indicates that the products must be properly recycled or disposed of appropriately in accordance with national legislation in the respective EU countries. If you wish to dispose of used electrical and electronic products outside the European Union, please contact your local authority so as to comply with the correct disposal method.

Certification

DATA MODUL AG is certified to ISO 9001:2008 and ISO 14001:2004 standards.

Disclaimer

The information in this Specification is subject to change without prior notice DATA MODUL. Although this Specification has been created with the utmost care, we cannot give any guarantee or accept any liability regarding the information provided.

Warranty

The warranty period of the eDM-COMB-SL6 is 24 months starting at the date of delivery from DATA MODUL.

Technical Support

Data Modul's technicians and engineers are committed to providing the best possible technical support for our customers so that our products can be easily used and implemented. We request that you first visit our website at www.data-modul.com for the latest documentation, utilities and drivers, which have been made available to assist you. If you still require assistance after visiting our website then contact our technical support department by email at support@data-modul.com.

COM Express Specification Reference

PICMG COM Express® Specification Rev. 2.1.

<http://www.picmg.org/>

Terminology

Term	Description
COM	A serial port interface on IBM PC-compatible computers.
COM Express	New generation technology of Computer On Module.
CPU	Central Processing Unit
DDC	Display Data Channel
DDI	Digital Display Interfaces
DDR3	Double Data Rate third generation SDRAM memory technology
DP	Display Port
DVI	Digital Visual Interface
EN	European Norm
ESD	Electrostatic Discharge
GND	Ground
GPIO	General Purpose Input/Output
HD	High Definition
HDMI	High Definition Multimedia Interface
I ² C	Inter-Integrated Circuit Bus
LAN	Local Area Network
LCD	Liquid Crystal Display
LPC	The Low Pin Count (LPC) Interface Specification for legacy I/O has facilitated the industry's transition toward ISA-less systems.
LVDS	Low Voltage Differential Signal
NA	Not Available
NC	Not Connected
PCB	Printed Circuit Board
PCH	Platform Controller Hub
PCIe	Peripheral Component Interconnect Express
PEG	PCI Express Graphics
RTC	Real Time Clock
SATA	Serial AT Attachment (serial interface standard for hard disks)
SBY	Standby
SMB	System Management Bus
SPI	Serial Peripheral Interface
TMDS	Transition Minimized Differential Signaling
TPM	Trusted Platform Module
VGA	Video Graphics Array
UART	A universal asynchronous receiver/transmitter that translates data between parallel and serial forms.
USB	Universal Serial Bus

Specifications

Supported Operating Systems

- Microsoft® Windows® 7
- Microsoft® Windows® Embedded 7 Standard (WES7)
- Microsoft® Windows® 8.1
- Microsoft® Windows® Embedded 8 Standard (WES8)
- Microsoft® Windows® 10
- Linux (Yocto)

Customized UEFI

DATA MODUL provides a UEFI firmware based on AMI Aptio-5 core. Specific features:

- Darkboot / Bootlogo support
- Legacy Free Operation
- Boot from external SPI as defined by COM Express specification
- Memory-initialization according to SPD, X.M.P. profiles supported
- LID and Sleep signals supported
- ACPI Wake Events - WOL S3-S5, USB S3-S5, LID S3, PwrBtn S3-S5
- AC Power Loss configurable by setup
- Spread Spectrum configurable by setup - default ON
- ACPI 4.0a
- DATA MODUL family feature: Embedded Controller specific

Tools

DATA MODUL provides the BIOS update tool, CPLD update tool, API test tool, and Utility to add/change the bootlogo.

Standards & Certifications

Environmentalism

- 2011/65/EU (of 8. June 2011 directive of the European parliament and of the council on the restriction of the use of certain hazardous substances in electrical and electronic equipment (RoHS))
- 2006/1907/EU (of 18. December 2006 of the European parliament and of the council concerning the Registration, Evaluation, Authorisation and Restriction of Chemicals (REACH))
- 2012/19/EC (of 04. July 2012 directive of the European parliament and of the council on waste electrical and electronic equipment (WEEE))
- The packing complies with directive 1994/62/EU.

EMC Standards

EMI/EMC: according to EN55022

Safety

Designed to meet UL60950.

Shock & Vibration

Shock and Vibration according to IEC/EN60068-2-6 and IEC/EN60068-2-27.

Block Diagram

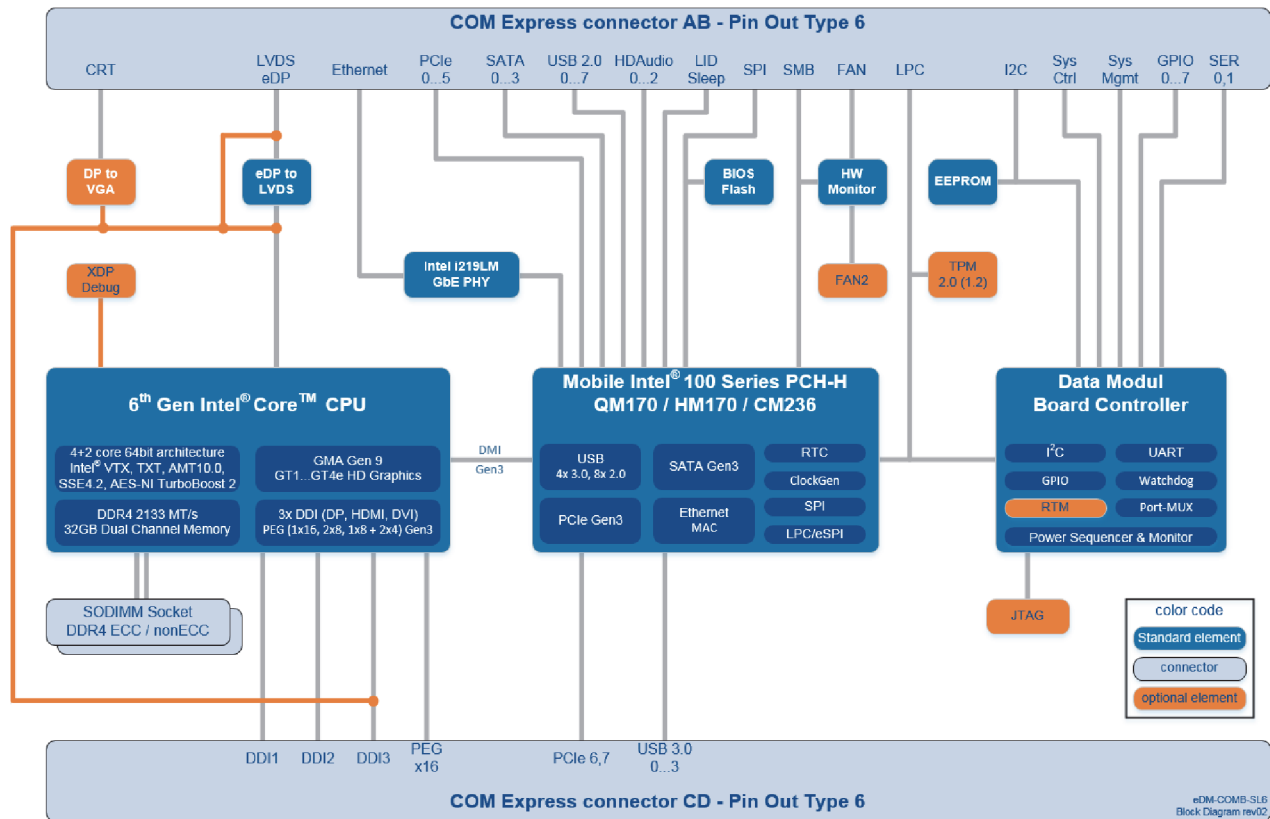

Ordering Information

Model Name	Part No.	Description
eDM-COMB-SL6-E3-1515MV5	12022515	COM Express Type 6 Basic with Intel® Xeon® E3-1515MV5, GT4, CM236 chipset, ECC
eDM-COMB-SL6-E3-1505LV5	12022516	COM Express Type 6 Basic with Intel® Xeon® E3-1505LV5, GT2, CM236 chipset, ECC
eDM-COMB-SL6-i7-6820EQ	12022507	COM Express Type 6 Basic with Intel® Core® i7-6820EQ, GT2, QM170 chipset
eDM-COMB-SL6-i7-6822EQ	12022508	COM Express Type 6 Basic with Intel® Core® i7-6822EQ, GT2, QM170 chipset
eDM-COMB-SL6-i5-6440EQ	12022509	COM Express Type 6 Basic with Intel® Core® i5-6440EQ, GT2, QM170 chipset
eDM-COMB-SL6-i56442EQ	12022510	COM Express Type 6 Basic with Intel® Core® i5-6442EQ, GT2, QM170 chipset
eDM-COMB-SL6-i3-6100E	12022511	COM Express Type 6 Basic with Intel® Core® i3-6100E, GT2, HM170 chipset
eDM-COMB-SL6-i3-6102E	12022512	COM Express Type 6 Basic with Intel® Core® i3-6102E, GT2, HM170 chipset
eDM-COMB-SL6-G3900E	12022513	COM Express Type 6 Basic with Intel® Celeron G3900E, GT1, HM170 chipset
eDM-COMB-SL6-G3902E	12022514	COM Express Type 6 Basic with Intel® Celeron G3902E, GT1, HM170 chipset
eDM-COMB-SL6-CF	12022742	Standard cooling solution with fan
eDM-COMB-SL6-CP	12022745	Standard cooling solution passive
eDM-COMB-SL6-CH	12022746	Standard heatspreader with 8mm standoff, 3mm plate, flat surface

Platform Features

Platform

The 6th Generation Intel® Core™ processor and Intel® Pentium® families are a 64-bit, multi-core processor built on 14-nanometer process technology (Skylake).

CPU

The eDM-COMB-SL6 supports all available Skylake CPUs in FCBGA1440 package, 14nm, up to 45W TDP.

- Package: 42 mm x 28 mm FCBGA1440

- Supported Features:
 - C-States: CO-C7
 - Intel® Virtualization Technology (Intel® VT)
 - Intel® Active Management Technology 11.0 (Intel® AMT 11.0)
 - Intel® Trusted Execution Technology (Intel® TXT)
 - Intel® Streaming SIMD Extensions 4.2 (Intel® SSE4.2)
 - Intel® Hyper-Threading Technology (Intel® HT Technology)
 - Intel® Turbo Boost Technology 2.0
- Security Features:
 - Intel® Advanced Encryption Standard New Instructions (Intel® AES-NI)
 - PCLMULQDQ (Perform Carry-Less Multiplication Quad word) Instruction
 - Intel® Security Key
 - Intel® Transactional Synchronization Extensions (Intel® TSX-NI)
 - PAIR – Power Aware Interrupt Routing
 - SMEP – Supervisor Mode Execution Protection
 - Intel® Boot Guard • Intel® Software Guard Extensions (Intel® SGX)
 - Intel® Memory Protection Extensions (Intel® MPX)
 - Intel® Processor Trace

Memory

- Two SO-DIMM sockets
- Memory type: DDR4, ECC/Non-ECC (variants with Intel CM236 chipset support ECC memory)
- Speed: up to 2133 MT/s
- Size: up to 32 GB

Chipset

- Mobile Intel® 100 Series Chipset QM170, HM170 and CM236

Graphics & Media

- Controller: Intel® Gen 9 HD Graphics Engine (GT1..GT4)
- Features: OpenCL 2.0, OpenGL 4.3 and DirectX12
 - Video Decode: H.265/HEVC @ level 5.1 (4k), H.264/AVC @ Level 5.1(4k), VC-1, WMV9, JPEG, VP8/VP9, MPEG2
 - Video Encode: H.265/HEVC @ level 5.1 (4k), H.264/AVC @ Level 5.1(4k), WMV9, JPEG, VP8/VP9, MPEG2
 - Imaging: MIPI-CSI 2, Intel® Image Signal Processor (ISP)
- Display Interfaces:
 - 3 x DDI (DP++, HDMI, DVI) / up to 4k resolution
 - 1 x VGA (optional)
 - 1 x Dual Channel 24 Bit LVDS up to 1920 x 1200 Pixel (optional eDP up to 4k resolution)

IO

- 4x USB 3.0 (XHCI), 8x USB 2.0 (EHCI)
- 2x UART (COM1/2)
- 4x SATA (6Gb/s), RAID 0/1/5/10 support, Rapid Storage Technology, Smart Response Technology
- 1x VGA (optional)
- 8x PCI Express Gen 3.0 lanes (x1/x2/x4 operation)
- 1x PEG x 16 Gen 3.0
- SPI
- LPC for Embedded Controller / TPM / external SIO
- GPIOs, 1MHz SMB 2.0
- Intel® HD Audio

LAN

Intel® i219-LM GbE LAN controller with AMT 11 support.

Additional Interfaces & Functions

LVDS

The eDM-COMB-SL6 supports Dual channel LVDS 1/2x18/24bit up to 1920x1200 from an eDP2LVDS converter like NXP PTN3460. Optionally it is possible to bypass LVDS converter to redirect the eDP signals to the COM Express connector pins by OR resistors placed stubless on the PCB.

VGA / CRT (optional)

The eDM-COMB-SL6 supports VGA/CRT from an DP2VGA converter. Optionally it is possible to bypass LVDS converter or connect to DDI3 pins by OR resistors placed stubless on the PCB.

TPM

Optionally the eDM-COMB-SL6 supports Trusted Platform Module (Version 2.0 and 1.2).

Hardware Monitor

Hardware Monitoring supports on the eDM-COMB-SL6 design using the Nuvoton NCT7802Y.

Hardware Monitor providing following information:

- CPU DIE temperature measured through PECE interface
- PCB temperature measured inside HWMonitor (place HWM at cool spot of PCB)
- Level of VCC module input voltage
- Level of 5V_SBY input voltage
- Level of VCCRTC voltage.

The Hardware Monitor provides control signals to operate one Fan connected at the COM Express baseboard fan connector and on board connector.

DATA MODUL Board Controller

The DATA MODUL Embedded Controller (DMEC) implements a set of typical embedded peripheral features in the Computer-On-Module (CoM) including devices like GPIO, I2C, Watchdog timers, UARTs etc. Depending on the DATA MODUL board type, the DMEC device is connected to the chipset either via LPC or eSPI.

The DMEC Controller on the eDM-COMB-SL6 module provides the following functionality:

- Connected to LPC on Intel Braswell SoC
- Two UARTs
 - Speed up to 115200Bd
 - I/O Address/IRQ configurable via BIOS setup.
 - UART1 optionally supports RTS/CTS signals through GPIOs, configurable via BIOS setup.
- I2C controller
 - Controls up to three I2C busses via multiplexer.
 - Supports Automatic Bus Clear to prevent bus hangs.
 - Supports Multiple masters on the bus. This feature is only supported if Automatic Bus Clear is off.
 - Supports FastMode+.
 - I2C speed configurable via BIOS setup.
 - Up to 400kHz in normal mode, up to 800kHz in FastMode+.
 - IRQ configurable via BIOS setup.
- Watchdog
 - Supports up to three stages.
 - Timeout per stage: 1ms- 65sec, with a granularity of 1ms or 128ms - ~140min, with a granularity of 128ms.
 - Supports Standard and Window Mode. Window mode is an advanced watchdog feature for safety critical applications. It only allows triggering the Watchdog within a specific time window. This covers the case where software hangs in a loop within the watchdog trigger routine.
 - Stage events include NMI, Reset and IRQ (if enabled in BIOS setup).
 - Supports Auto Reload (allows to use the Watchdog as an event ticker).
 - Supports register lock to prevent the Watchdog from being disabled or its configuration being changed in safety critical applications.
 - Fully configurable via BIOS setup.

- COM Express GPIOs:
 - Supports eight bi-directional GPIOs.
 - Initial state (In/Out, High/Low, set during early POST) can be configured via BIOS setup.
 - Capable to generate IRQ events (if IRQ enabled in BIOS setup). For details on how to enable IRQ generation please refer to the DMEC Functional Specification.
 - Additional GPIO function configurable via BIOS setup:
 - GPIO4: GPIO or UART1 CTS or PWM0
 - GPIO5: GPIO or WD Kick Input or UART1 RTS or PWM1
 - GPIO6: GPIO or I2C2 CL
 - GPIO7: GPIO or I2C2 SDA.
- PWM controller
 - Supports either two independent 8Bit channels or one 16Bit channel for higher resolution for example in DAC applications.
 - Left or center aligned PWM output
 - Programmable period and double buffered duty cycle registers
 - Configurable output polarity
 - Wide range PWM period configurable per channel via programmable pre-scaler".

Most common features are accessible through EApi function calls. EApi support and drivers for the DMEC device are available for Windows and Linux. For details on the DMEC register layout please refer to the DMEC Functional Specification which is available from DATA MODUL on request.

OnModule Memory

An 16MByte SPI in SO-8 package flash to store EFI and setup configuration shall be used on the eDM-COMB-SL6 design. A 32kbit I2C EEPROM configured to address AE/AF shall be connected to the fast I2C bus of the Embedded Controller and also to the I2C interface of the COM Express connector.

Environmental Specification

The eDM-COMB-SL6 is able to be operated and stored under the following environmental conditions:

- Temperature (operating): 0°C ... +60°C (commercial grade)
Extended temperature ranges on request.
- Temperature (storage): -20°C ... +80°C
- Humidity (operating): 5% ... 90% RH non-condensing
- Humidity (storage): 5% ... 95% RH non-condensing
- Tolerable air pressure: > 708 hPa (approx. altitude 2000m)

Power Supply

Input Voltage

- VCC: 12.0V ± 5%
- 5V_SBY: 5.0V ± 5%
- Modes: ATX Mode or VCC only without 5V_SBY

Specifications

- Voltage Ripple: max. 100mV peak to peak 0 ... 20 MHz
- Rise Time: 0.1 ... 20ms from input voltage < 10% nominal VCC
- Max. allowed Inrush Current

5V_SBY:	2A
VCC:	10A

Power Features

- **Reset Button Behavior**
Module resets immediately when reset button is pressed in S0 state.
Module stays in reset condition when reset button is pressed and hold in any system state < S0.
- **Power Button Behavior**
Module stays in S5 state when switched on in ATX mode and wait for power button event.
Module boots to S0 state when switched on in VCC-only mode.

COM Express Connectors & Signal Descriptions

Connector Location

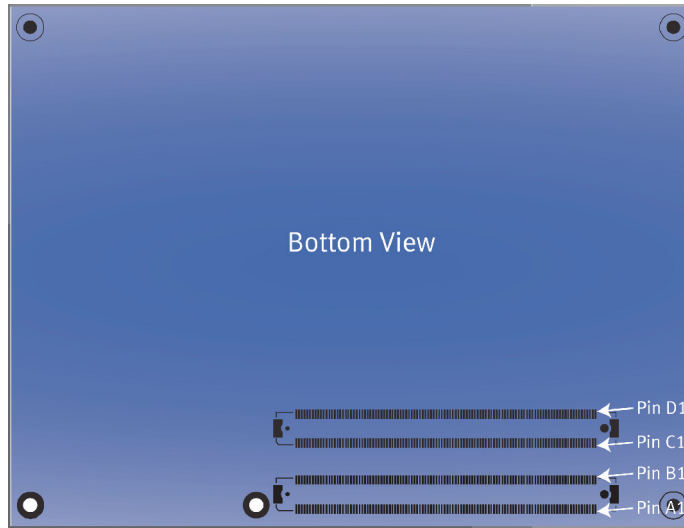

General Signal Description

Type	Description
I/O-3.3	Bi-directional 3.3 V Input/Output-Signal
I/O-5T	Bi-directional 3.3 V Input/Output (5V Tolerance)
I/O-5	Bi-directional 5 V Input/Output-Signal
I3.3	3.3 V Input
I/OD	Bi-directional 3.3 V Input/Output Open Drain
I-5T	3.3 V Input (5V Tolerance)
OA	Output Analog
OD	Output Open Drain
O-1.8	1.8 V Output
O-3.3	3.3 V Output
O-5	5 V Output
DP-I/O	Differential Pair Input/Output
DP-I	Differential Pair Input
DP-O	Differential Pair Output
PU	Pull-Up Resistor
PD	Pull-Down Resistor
PWR	Power Connection

COM Express Connector Pinouts

The termination resistors in these tables are already mounted on the module. Refer to the COM Express design guide for information about additional termination resistors.

Connector J1 Row A

Pin	Signal	Description	Type	Termination	Comment
A1	GND	Power Ground	PWR GND	-	-
A2	GBE0_MDI3-	Ethernet Media Dependent Interface 3-	DP-I/O	-	-
A3	GBE0_MDI3+	Ethernet Media Dependent Interface 3+	DP-I/O	-	-
A4	GBE0_LINK100#	Ethernet Speed LED	OD	-	can sink 100mA

A5	GBE0_LINK1000#	Ethernet Speed LED	OD	-	can sink 100mA
A6	GBE0_MDI2-	Ethernet Media Dependent Interface 2 -	DP-I/O	-	-
A7	GBE0_MDI2+	Ethernet Media Dependent Interface 2 +	DP-I/O	-	-
A8	GBE0_LINK#	LAN Link LED	OD	-	can sink 100mA
A9	GBE0_MDI1-	Ethernet Media Dependent Interface 1 -	DP-I/O	-	-
A10	GBE0_MDI1+	Ethernet Media Dependent Interface 1 +	DP-I/O	-	-
A11	GND	Power Ground	PWR GND	-	-
A12	GBE0_MDI0-	Ethernet Media Dependent Interface 0 -	DP-I/O	-	-
A13	GBE0_MDI0+	Ethernet Media Dependent Interface 0 +	DP-I/O	-	-
A14	GBE0_CTREF	Center Tab Reference Voltage	0	-	1µF capacitor to GND
A15	SUS_S3#	Suspend To RAM (or deeper) Indicator	0-3.3	PD 20k	-
A16	SATA0_TX+	SATA Transmit Pair 0 +	DP-0	-	-
A17	SATA0_TX-	SATA Transmit Pair 0 -	DP-0	-	-
A18	SUS_S4#	Suspend To Disk (or deeper) Indicator	0-3.3	PD 20k	-
A19	SATA0_RX+	SATA Receive Pair 0 +	DP-I	-	-
A20	SATA0_RX-	SATA Receive Pair 0 -	DP-I	-	-
A21	GND	Power Ground	PWR GND	-	-
A22	SATA2_TX+	SATA Transmit Pair 2 +	DP-0	-	-
A23	SATA2_TX-	SATA Transmit Pair 2 -	DP-0	-	-
A24	SUS_S5#	Soft Off Indicator	0-3.3	PD 20k	-
A25	SATA2_RX+	SATA Receive Pair 2 +	DP-I		
A26	SATA2_RX-	SATA Receive Pair 2 -	DP-I		
A27	BATLOW#	Battery Low	I-3.3	PU 10k 3.3V (S5)	assertion will prevent wake from S3-S5 state
A28	(S)ATA_ACT#	Serial ATA activity LED	OD-3.3	PU 10k 3.3V (S0)	can sink 200mA
A29	AC/HDA_SYNC	HD Audio Sync	0-3.3	PD 15k in PCH	-
A30	AC/HDA_RST#	HD Audio Reset	0-3.3	PD 15k in PCH	-
A31	GND	Power Ground	PWR GND	-	-
A32	AC/HDA_BITCLK	HD Audio Bit Clock Output	0-3.3	PD 15k in PCH	-
A33	AC/HDA_SDOUT	HD Audio Serial Data Out	0-3.3	PD 15k in PCH	-
A34	BIOS_DIS0#	BIOS Selection Strap 0	I-3.3	PU 100k 3.3V (SPI)	-
A35	THRMTRIP#	Thermal Trip	0-3.3	PU 10k 3.3V (S0)	do not use as this signal, because there is no difference between regular and over-temperature shutdown
A36	USB6-	USB 2.0 Data Pair Port 6 -	DP-I/O	PD in PCH	-
A37	USB6+	USB 2.0 Data Pair Port 6 +	DP-I/O	PD in PCH	-
A38	USB_6_7_OC#	USB Overcurrent Indicator Port 6/7	I-3.3	PU 10k 3.3V (S5)	-
A39	USB4-	USB 2.0 Data Pair Port 4 -	DP-I/O	PD in PCH	-
A40	USB4+	USB 2.0 Data Pair Port 4 +	DP-I/O	PD in PCH	-
A41	GND	Power Ground	PWR GND	-	-
A42	USB2-	USB 2.0 Data Pair Port 2 -	DP-I/O	PD in PCH	-
A43	USB2+	USB 2.0 Data Pair Port 2 +	DP-I/O	PD in PCH	-
A44	USB_2_3_OC#	USB Overcurrent Indicator Port 2/3	I-3.3	PU 10k 3.3V (S5)	-
A45	USB0-	USB 2.0 Data Pair Port 0 -	DP-I/O	PD in PCH	-
A46	USB0+	USB 2.0 Data Pair Port 0 +	DP-I/O	PD in PCH	-
A47	VCC_RTC	Real-Time Clock Circuit Power Input	PWR 3V	-	voltage range 2.7-3.47V
A48	EXCD0_PERST#	Express Card Reset Port 0	0-3.3	-	-
A49	EXCD0_CPPE#	Express Card Capable Card Request Port 0	I-3.3	PU 10k 3.3V (S0)	-

A50	LPC_SERIRQ	Serial Interrupt Request	I/OD-3.3	PU 8k25k 3.3V (S0)	-
A51	GND	Power Ground	PWR GND	-	-
A52	PCIE_TX5+	PCI Express Lane 5 Transmit +	DP-0	-	-
A53	PCIE_TX5-	PCI Express Lane 5 Transmit -	DP-0	-	-
A54	GPI0	General Purpose Input 0	I-3.3	PU 10k 3.3V (S0)	-
A55	PCIE_TX4+	PCI Express Lane 4 Transmit +	DP-0	-	-
A56	PCIE_TX4-	PCI Express Lane 4 Transmit -	DP-0	-	-
A57	GND	Power Ground	PWR GND	-	-
A58	PCIE_TX3+	PCI Express Lane 3 Transmit +	DP-0	-	-
A59	PCIE_TX3-	PCI Express Lane 3 Transmit -	DP-0	-	-
A60	GND	Power Ground	PWR GND	-	-
A61	PCIE_TX2+	PCI Express Lane 2 Transmit +	DP-0	-	-
A62	PCIE_TX2-	PCI Express Lane 2 Transmit -	DP-0	-	-
A63	GPI1	General Purpose Input 1	I-3.3	PU 10k 3.3V (S0)	-
A64	PCIE_TX1+	PCI Express Lane 1 Transmit +	DP-0	-	-
A65	PCIE_TX1-	PCI Express Lane 1 Transmit -	DP-0	-	-
A66	GND	Power Ground	PWR GND	-	-
A67	GPI2	General Purpose Input 2	I-3.3	PU 10k 3.3V (S0)	-
A68	PCIE_TX0+	PCI Express Lane 0 Transmit +	DP-0	-	-
A69	PCIE_TX0-	PCI Express Lane 0 Transmit -	DP-0	-	-
A70	GND	Power Ground	PWR GND	-	-
A71	LVDS_A0+/eDP_TX2+	LVDS Channel A Data0 + (shared eDP TX2+)	DP-0	-	configuration as eDP_TX2+ in customized article version possible
A72	LVDS_A0-/eDP_TX2-	LVDS Channel A Data0 - (shared eDP TX2-)	DP-0	-	configuration as eDP_TX2- in customized article version possible
A73	LVDS_A1+/eDP_TX1+	LVDS Channel A Data0 - (shared eDP TX2-)	DP-0	-	configuration as eDP_TX1+ in customized article version possible
A74	LVDS_A1-/eDP_TX1-	LVDS Channel A Data1 - (shared eDP TX1-)	DP-0	-	configuration as eDP_TX1- in customized article version possible
A75	LVDS_A2+/eDP_TX0+	LVDS Channel A Data2 + (shared eDP TX0+)	DP-0	-	configuration as eDP_TX0+ in customized article version possible
A76	LVDS_A2-/eDP_TX0-	LVDS Channel A Data2 + (shared eDP TX0-)	DP-0	-	configuration as eDP_TX0- in customized article version possible
A77	LVDS/eDP_VDD_EN	LVDS (or eDP) Panel Power Control	O-3.3	PD 100k	configuration as eDP_VDD_EN in customized article version possible
A78	LVDS_A3+	LVDS Channel A Data3 +	DP-0	-	-
A79	LVDS_A3-	LVDS Channel A Data3 -	DP-0	-	-
A80	GND	Power Ground	PWR GND	-	-
A81	LVDS_A_CK+/eDP_TX3+	LVDS Channel A Clock (shared eDP TX3+)	DP-0	-	configuration as eDP_TX3+ in customized article version possible
A82	LVDS_A_CK-/eDP_TX3-	LVDS Channel A Clock - (shared eDP TX3-)	DP-0	-	configuration as eDP_TX3- in customized article version possible
A83	LVDS_I2C_CK/eDP_AUX+	LVDS Data Channel Data (shared eDP AUX-)	I/O-3.3	PU 2k2 3.3V (S0)	configuration as eDP_AUX+ in customized article version possible

A84	LVDS_I2C_DAT/eDP_AUX-	LVDS Data Channel Data (shared eDP AUX-)	I/O-3.3	PU 2k2 3.3V (S0)	configuration as eDP_AUX- in customized article version possible
A85	GPI3	General Purpose Input 3	I-3.3	PU 10k 3.3V (S0)	-
A86	RSVD	Reserved for future use	nc	-	-
A87	RSVD/eDP_HPDP	Reserved (shared eDP hot plug detection)	nc/I-3.3	100k PD (opt)	configuration as eDP_HPDP in customized article version possible
A88	PCIE_CLK_REF+	Reference PCI Express Clock +	DP-0	-	-
A89	PCIE_CLK_REF-	Reference PCI Express Clock -	DP-0	-	-
A90	GND	Power Ground	PWR GND	-	-
A91	SPI_POWER	3.3V Power Output Pin for external SPI flash	O-3.3	-	-
A92	SPI_MISO	SPI Master IN Slave OUT	I-3.3	PU 20k in PCH	All SPI signals are tri-stated with 20k ohm PCH internal weak pull-up until reset is deasserted.
A93	GPO0	General Purpose Output 0	O-3.3	PD 10k	-
A94	SPI_CLK	SPI Clock	O-3.3	PU 20k in PCH	All SPI signals are tri-stated with 20k ohm PCH internal weak pull-up until reset is deasserted.
A95	SPI_MOSI	SPI Master Out Slave In	O-3.3	PU 20k in PCH	All SPI signals are tri-stated with 20k ohm PCH internal weak pull-up until reset is deasserted.
A96	TPM_PP	No connect/TPM Physical Presence	nc/I-3.3	100k PD	configuration as TPM_PP in customized article version possible
A97	TYPE10#	No connect for TYPE 6 module	nc	-	-
A98	SER0_TX	Serial Port 0 TXD	O-3.3	-	20V protection circuit implemented on module, PD on carrier board needed for proper operation.
A99	SER0_RX	Serial Port 0 RXD	I-5T	PU 47k 3.3V (S0)	20V protection circuit implemented on module
A100	GND	Power Ground	PWR GND	-	-
A101	SER1_TX	Serial Port 1 RXD	O-3.3	-	20V protection circuit implemented on module, PD on carrier board needed for proper operation.
A102	SER1_RX	Serial Port 1 RXD	I-5T	PU 47k 3.3V (S0)	20V protection circuit implemented on module
A103	LID#	LID Switch Input	I-3.3	PU 47k 3.3V (S5)	20V protection circuit implemented on module
A104	VCC_12V	Main Input Voltage	PWR 12V	-	-
A105	VCC_12V	Main Input Voltage	PWR 12V	-	-
A106	VCC_12V	Main Input Voltage	PWR 12V	-	-
A107	VCC_12V	Main Input Voltage	PWR 12V	-	-
A108	VCC_12V	Main Input Voltage	PWR 12V	-	-
A109	VCC_12V	Main Input Voltage	PWR 12V	-	-
A110	GND	Power Ground	PWR GND	-	-

Connector J1 Row B

Pin	Signal	Description	Type	Termination	Comment
B1	GND	Power Ground	PWR GND	-	-
B2	GBE0_ACT	Ethernet Activity LED	OD	-	can sink 100mA
B3	LPC_FRAME#	LPC Frame Indicator	O-3.3	-	-
B4	LPC_ADO	LPC Multiplexed Command, Address & Data 0	I/O-3.3	PU 20k in PCH	-

B5	LPC_AD1	LPC Multiplexed Command, Address & Data 1	I/O-3.3	PU 20k in PCH	-
B6	LPC_AD2	LPC Multiplexed Command, Address & Data 2	I/O-3.3	PU 20k in PCH	-
B7	LPC_AD3	LPC Multiplexed Command, Address & Data 3	I/O-3.3	PU 20k in PCH	-
B8	LPC_DRQ0#	LPC Serial DMA/Master Request 0	I-3.3	PU 20k in PCH	-
B9	LPC_DRQ1#	LPC Serial DMA/Master Request 1	I-3.3	PU 20k in PCH	-
B10	LPC_CLK	33MHz LPC clock	O-3.3	PU 20k in PCH	-
B11	GND	Power Ground	PWR GND	-	-
B12	PWRBTN#	Power Button	I-3.3	PU 10k 3.3V (S5)	-
B13	SMB_CK	SMBUS Clock	O-3.3	PU 3k3 3.3V (S5)	-
B14	SMB_DAT	SMBUS Data	I/O-3.3	PU 3k3 3.3V (S5)	-
B15	SMB_ALERT#	SMBUS Alert	I/O-3.3	PU 4k7 3.3V (S5)	-
B16	SATA1_TX+	SATA 1 Transmit Pair +	DP-0	-	-
B17	SATA1_TX-	SATA 1 Transmit Pair -	DP-0	-	-
B18	SUS_STAT#	Suspend Status	O-3.3	-	-
B19	SATA1_RX+	SATA 1 Receive Pair +	DP-I	-	-
B20	SATA1_RX-	SATA 1 Receive Pair -	DP-I	-	-
B21	GND	Power Ground	PWR GND	-	-
B22	SATA3_TX+	SATA 3 Transmit Pair +	DP-0	-	-
B23	SATA3_TX-	SATA 3 Transmit Pair -	DP-0	-	-
B24	PWR_OK	Power OK	I-5T	PU 500k 3.3V	-
B25	SATA3_RX+	SATA 3 Receive Pair +	DP-I	-	-
B26	SATA3_RX-	SATA 3 Receive Pair -	DP-I	-	-
B27	WDT	Watch Dog Time-Out event	O-3.3	-	-
B28	AC/HDA_SDIN2	HD Audio Serial Data In 2	I-3.3	PD 15k in PCH	-
B29	AC/HDA_SDIN1	HD Audio Serial Data In 1	I-3.3	PD 15k in PCH	-
B30	AC/HDA_SDIN0	HD Audio Serial Data In 0	I-3.3	PD 15k in PCH	-
B31	GND	Power Ground	PWR GND	-	-
B32	SPKR	Speaker	O-3.3	PD 20k in PCH	-
B33	I2C_CK	I2C Clock	O-3.3	PU 2k4 3.3V (S5)	-
B34	I2C_DAT	I2C Data	I/O-3.3	PU 2k4 3.3V (S5)	-
B35	THRM#	Over Temperature Input	I-3.3	PU ca. 47k in FPGA 3.3V (S0)	-
B36	USB7-	USB 2.0 Data Pair Port 7 -	DP-I/O	PD in PCH	-
B37	USB7+	USB 2.0 Data Pair Port 7 +	DP-I/O	PD in PCH	-
B38	USB_4_5_OC#	USB Overcurrent Indicator Port 4/5	I-3.3	PU 10k 3.3V (S5)	-
B39	USB5-	USB 2.0 Data Pair Port 5 -	DP-I/O	PD in PCH	-
B40	USB5+	USB 2.0 Data Pair Port 5 +	DP-I/O	PD in PCH	-
B41	GND	Power Ground	PWR GND	-	-
B42	USB3-	USB 2.0 Data Pair Port 3 -	DP-I/O	PD in PCH	-
B43	USB3+	USB 2.0 Data Pair Port 3 +	DP-I/O	PD in PCH	-
B44	USB_0_1_OC#	USB Overcurrent Indicator Port 0/1	I-3.3	PU 10k 3.3V (S5)	-
B45	USB1-	USB 2.0 Data Pair Port 1 -	DP-I/O	PD in PCH	-
B46	USB1+	USB 2.0 Data Pair Port 1 +	DP-I/O	PD in PCH	-

B47	EXCD1_PERST#	Express Card Reset Port 1	O-3.3	-	-
B48	EXCD1_CPPE#	Express Card Capable Card Request Port 1	I-3.3	PU 10k 3.3V (S0)	-
B49	SYS_RESET#	Reset Button Input	O-3.3	PU 10k 3.3V (S0)	-
B50	CB_RESET#	Carrier Board Reset	O-3.3	-	-
B51	GND	Power Ground	PWR GND	-	-
B52	PCIE_RX5+	PCI Express Lane 5 Receive +	DP-I	-	-
B53	PCIE_RX5-	PCI Express Lane 5 Receive -	DP-I	-	-
B54	GPO1	General Purpose Output 1	O-3.3	PD 10k	-
B55	PCIE_RX4+	PCI Express Lane 4 Receive +	DP-I	-	-
B56	PCIE_RX4-	PCI Express Lane 4 Receive -	DP-I	-	-
B57	GPO2	General Purpose Output 2	O-3.3	PD 10k	-
B58	PCIE_RX3+	PCI Express Lane 3 Receive +	DP-I	-	-
B59	PCIE_RX3-	PCI Express Lane 3 Receive -	DP-I	-	-
B60	GND	Power Ground	PWR GND	-	-
B61	PCIE_RX2+	PCI Express Lane 2 Receive +	DP-I	-	-
B62	PCIE_RX2-	PCI Express Lane 2 Receive -	DP-I	-	-
B63	GPO3	General Purpose Output 3	O-3.3	PD 10k	-
B64	PCIE_RX1+	PCI Express Lane 1 Receive +	DP-I	-	-
B65	PCIE_RX1-	PCI Express Lane 1 Receive -	DP-I	-	-
B66	WAKE0#	PCI Express Wake Event	I-3.3	PU 10k 3.3V (S5)	-
B67	WAKE1#	General Purpose Wake Event	I-3.3	PU 10k 3.3V (S5)	-
B68	PCIE_RX0+	PCI Express Lane 0 Receive +	DP-I	-	-
B69	PCIE_RX0-	PCI Express Lane 0 Receive -	DP-I	-	-
B70	GND	Power Ground	PWR GND	-	-
B71	LVDS_B0+	LVDS Channel B Data0 +	DP-O	-	-
B72	LVDS_B0-	LVDS Channel B Data0 -	DP-O	-	-
B73	LVDS_B1+	LVDS Channel B Data1 +	DP-O	-	-
B74	LVDS_B1-	LVDS Channel B Data1 -	DP-O	-	-
B75	LVDS_B2+	LVDS Channel B Data2 +	DP-O	-	-
B76	LVDS_B2-	LVDS Channel B Data2 -	DP-O	-	-
B77	LVDS_B3+	LVDS Channel B Data3 +	DP-O	-	-
B78	LVDS_B3-	LVDS Channel B Data3 -	DP-O	-	-
B79	LVDS/eDP_BKLT_EN	Panel Backlight On	O-3.3	PD 100k	configuration as eDP_BKLT_EN in customized article version possible
B80	GND	Power Ground	PWR GND	-	-
B81	LVDS_B_CK+	LVDS Channel B Clock +	DP-O	-	-
B82	LVDS_B_CK-	LVDS Channel B Clock -	DP-O	-	-
B83	LVDS_BKLT_CTRL	Backlight Brightness Control	O-3.3	PD 100k	configuration as eDB_BKLT_CTRL ...
B84	VCC_5V_SBY	5V Standby	PWR 5V (S5)	-	optional (not necessary in single supply mode)
B85	VCC_5V_SBY	5V Standby	PWR 5V (S5)	-	optional (not necessary in single supply mode)
B86	VCC_5V_SBY	5V Standby	PWR 5V (S5)	-	optional (not necessary in single supply mode)
B87	VCC_5V_SBY	5V Standby	PWR 5V (S5)	-	optional (not necessary in single supply mode)
B88	BIOS_DIS1#	BIOS Selection Strap 1	I-3.3	PU 100k 3.3V (SPI)	-

B89	VGA_RED	No connect/Red Analog Video Output	nc/OA	PD 150R	optional in product versions with assembled VGA-Bridge
B90	GND	Power Ground	PWR GND	-	-
B91	VGA_GRN	No connect/Green Analog Video Output	nc/OA	PD 150R	optional in product versions with assembled VGA-Bridge
B92	VGA_BLU	No connect/Blue Analog Video Output	nc/OA	PD 150R	
B93	VGA_HSYNC	No connect/VGA Horizontal Synchronisation	nc/O-3.3	-	
B94	VGA_VSYNC	No connect/VGA Vertical Synchronization	nc/O-3.3	-	
B95	VGA_I2C_CK	No connect/VGA Data Channel Clock	nc/I/O-3.3	PU 1k 3.3V (S0)	
B96	VGA_I2C_DAT	No connect/VGA Data Channel Data	nc/I/O-3.3	PU 1k 3.3V (S0)	
B97	SPI_CS#	SPI Chip Select	O-3.3	-	-
B98	RSVD	Reserved for future use	nc	-	-
B99	RSVD	Reserved for future use	nc	-	-
B100	GND	Power Ground	PWR GND	-	-
B101	FAN_PWMOUT	Fan PWM Output	O-3.3	-	20V protection circuit implemented on module, PD on carrier board needed for proper operation.
B102	FAN_TACHIN	Fan Tach Input	I-3.3	PU 10k 3.3V (S0)	20V protection circuit implemented on module
B103	SLEEP#	Sleep Button Input	I-3.3	PU 47k 3.3V (S5)	20V protection circuit implemented on module
B104	VCC_12V	Main Input Voltage	PWR 12V	-	-
B105	VCC_12V	Main Input Voltage	PWR 12V	-	-
B106	VCC_12V	Main Input Voltage	PWR 12V	-	-
B107	VCC_12V	Main Input Voltage	PWR 12V	-	-
B108	VCC_12V	Main Input Voltage	PWR 12V	-	-
B109	VCC_12V	Main Input Voltage	PWR 12V	-	-
B110	GND	Power Ground	PWR GND	-	-

Connector J1 Row C

Pin	Signal	Description	Type	Termination	Comment
C1	GND	Power Ground	PWR GND	-	-
C2	GND	Power Ground	PWR GND	-	-
C3	USB_SSRX0-	USB Super Speed Receive Port 0 -	DP-I	-	-
C4	USB_SSRX0+	USB Super Speed Receive Port 0 +	DP-I	-	-
C5	GND	Power Ground	PWR GND	-	-
C6	USB_SSRX1-	USB Super Speed Receive Port 1 -	DP-I	-	-
C7	USB_SSRX1+	USB Super Speed Receive Port 1 +	DP-I	-	-
C8	GND	Power Ground	PWR GND	-	-
C9	USB_SSRX2-	USB Super Speed Receive Port 2 -	DP-I	-	-
C10	USB_SSRX2+	USB Super Speed Receive Port 2 +	DP-I	-	-
C11	GND	Power Ground	PWR GND	-	-
C12	USB_SSRX3-	USB Super Speed Receive Port 3 -	DP-I	-	-
C13	USB_SSRX3+	USB Super Speed Receive Port 3+	DP-I	-	-
C14	GND	Power Ground	PWR GND	-	-
C15	DDI1_PAIR6+	No connect	nc	-	not supported by Intel's PCH
C16	DDI1_PAIR6-	No connect	nc	-	not supported by Intel's PCH
C17	RSVD	Reserved for future use	nc	-	-
C18	RSVD	Reserved for future use	nc	-	-
C19	PCIE_RX6+	PCI Express Lane 6 Receive +	DP-I	-	-
C20	PCIE_RX6-	PCI Express Lane 6 Receive -	DP-I	-	-

C21	GND	Power Ground	PWR GND	-	-
C22	PCIE_RX7+	PCI Express Lane 7 Receive +	DP-I	-	-
C23	PCIE_RX7-	PCI Express Lane 7 Receive -	DP-I	-	-
C24	DDI1_HPD	DDI1 Hotplug Detect	I-3.3	PD 100k	-
C25	DDI1_PAIR4+	No connect	nc	-	not supported by Intel's PCH
C26	DDI1_PAIR4-	No connect	nc	-	not supported by Intel's PCH
C27	RSVD	Reserved for future use	nc	-	-
C28	RSVD	Reserved for future use	nc	-	-
C29	DDI1_PAIR5+	No connect	DP-I	-	not supported by Intel's PCH
C30	DDI1_PAIR5-	No connect	DP-I	-	not supported by Intel's PCH
C31	GND	Power Ground	PWR GND	-	-
C32	DDI2_CTRLCLK_AUX+	Multiplexed DDI2 Data Channel Clock & AUX +	I/O-3.3	PD 100k	2k21 PU (S0) when DDI2_DDC_AUX_SEL is high
C33	DDI2_CTRLCLK_AUX-	Multiplexed DDI2 Data Channel Clock & AUX -	I/O-3.3	PU 100k (S0)	2k21 PU (S0) when DDI2_DDC_AUX_SEL is high
C34	DDI2_DDC_AUX_SEL	DDI2 DDC/AUX Select	I-3.3	PD 1MEG	-
C35	RSVD	Reserved for future use	nc	-	-
C36	DDI3_CTRLCLK_AUX+	Multiplexed DDI3 Data Channel Clock & AUX +	I/O-3.3	PD 100k	2k21 PU (S0) when DDI3_DDC_AUX_SEL is high
C37	DDI3_CTRLCLK_AUX-	Multiplexed DDI3 Data Channel Clock & AUX -	I/O-3.3	PU 100k (S0)	2k21 PU (S0) when DDI3_DDC_AUX_SEL is high
C38	DDI3_DDC_AUX_SEL	DDI3 DDC/AUX Select	I-3.3	PD 1MEG	-
C39	DDI3_PAIR0+	DDI3 Pair 0 +	DP-O	-	-
C40	DDI3_PAIR0-	DDI3 Pair 0 -	DP-O	-	-
C41	GND	Power Ground	PWR GND	-	-
C42	DDI3_PAIR1+	DDI3 Pair 1 +	DP-O	-	-
C43	DDI3_PAIR1-	DDI3 Pair 1 -	DP-O	-	-
C44	DDI3_HPD	DDI3 Hotplug Detect	I-3.3	PD 100k	-
C45	RSVD	Reserved for future use	nc	-	-
C46	DDI3_PAIR2+	DDI3 Pair 2 +	DP-O	-	-
C47	DDI3_PAIR2-	DDI3 Pair 2 -	DP-O	-	-
C48	RSVD	Reserved for future use	nc	-	-
C49	DDI3_PAIR3+	DDI3 Pair 3 +	DP-O	-	-
C50	DDI3_PAIR3-	DDI3 Pair 3 -	DP-O	-	-
C51	GND	Power Ground	PWR GND	-	-
C52	PEG_RX0+	PCI Express Graphics Lane 0 Receive +	DP-I	-	-
C53	PEG_RX0-	PCI Express Graphics Lane 0 Receive -	DP-I	-	-
C54	TYPE0#	No Connect for TYPE 6 module	nc	-	-
C55	PEG_RX1+	PCI Express Graphics Lane 1 Receive +	DP-I	-	-
C56	PEG_RX1-	PCI Express Graphics Lane 1 Receive -	DP-I	-	-
C57	TYPE1#	No Connect for TYPE 6 module	nc	-	-
C58	PEG_RX2+	PCI Express Graphics Lane 2 Receive +	DP-I	-	-
C59	PEG_RX2-	PCI Express Graphics Lane 2 Receive -	DP-I	-	-
C60	GND	Power Ground	PWR GND	-	-
C61	PEG_RX3+	PCI Express Graphics Lane 3 Receive +	DP-I	-	-
C62	PEG_RX3-	PCI Express Graphics Lane 3 Receive -	DP-I	-	-
C63	RSVD	Reserved for future use	nc	-	-
C64	RSVD	Reserved for future use	nc	-	-
C65	PEG_RX4+	PCI Express Graphics Lane 4 Receive +	DP-I	-	-
C66	PEG_RX4-	PCI Express Graphics Lane 4 Receive -	DP-I	-	-
C67	RSVD	Reserved for future use	nc	-	-
C68	PEG_RX5+	PCI Express Graphics Lane 5 Receive +	DP-I	-	-

C69	PEG_RX5-	PCI Express Graphics Lane 5 Receive -	DP-I	-	-
C70	GND	Power Ground	PWR GND	-	-
C71	PEG_RX6+	PCI Express Graphics Lane 6 Receive +	DP-I	-	-
C72	PEG_RX6-	PCI Express Graphics Lane 6 Receive -	DP-I	-	-
C73	GND	Power Ground	PWR GND	-	-
C74	PEG_RX7+	PCI Express Graphics Lane 7 Receive +	DP-I	-	-
C75	PEG_RX7-	PCI Express Graphics Lane 7 Receive -	DP-I	-	-
C76	GND	Power Ground	nc	-	-
C77	RSVD	Reserved for future use	nc	-	-
C78	PEG_RX8+	PCI Express Graphics Lane 8 Receive +	DP-I	-	-
C79	PEG_RX8-	PCI Express Graphics Lane 8 Receive -	DP-I	-	-
C80	GND	Power Ground	PWR GND	-	-
C81	PEG_RX9+	PCI Express Graphics Lane 9 Receive +	DP-I	-	-
C82	PEG_RX9-	PCI Express Graphics Lane 9 Receive -	DP-I	-	-
C83	RSVD	Reserved for future use	nc	-	-
C84	GND	Power Ground	PWR GND	-	-
C85	PEG_RX10+	PCI Express Graphics Lane 10 Receive +	DP-I	-	-
C86	PEG_RX10-	PCI Express Graphics Lane 10 Receive -	DP-I	-	-
C87	GND	Power Ground	PWR GND	-	-
C88	PEG_RX11+	PCI Express Graphics Lane 11 Receive +	DP-I	-	-
C89	PEG_RX11-	PCI Express Graphics Lane 11 Receive -	DP-I	-	-
C90	GND	Power Ground	PWR GND	-	-
C91	PEG_RX12+	PCI Express Graphics Lane 12 Receive +	DP-I	-	-
C92	PEG_RX12-	PCI Express Graphics Lane 12 Receive -	DP-I	-	-
C93	GND	Power Ground	PWR GND	-	-
C94	PEG_RX13+	PCI Express Graphics Lane 13 Receive +	DP-I	-	-
C95	PEG_RX13-	PCI Express Graphics Lane 13 Receive -	DP-I	-	-
C96	GND	Power Ground	PWR GND	-	-
C97	RSVD	Reserved for future use	nc	-	-
C98	PEG_RX14+	PCI Express Graphics Lane 14 Receive +	DP-I	-	-
C99	PEG_RX14-	PCI Express Graphics Lane 14 Receive -	DP-I	-	-
C100	GND	Power Ground	PWR GND	-	-
C101	PEG_RX15+	PCI Express Graphics Lane 15 Receive +	DP-I	-	-
C102	PEG_RX15-	PCI Express Graphics Lane 15 Receive -	DP-I	-	-
C103	GND	Power Ground	PWR GND	-	-
C104	VCC_12V	Main Input Voltage	PWR 12V	-	-
C105	VCC_12V	Main Input Voltage	PWR 12V	-	-
C106	VCC_12V	Main Input Voltage	PWR 12V	-	-
C107	VCC_12V	Main Input Voltage	PWR 12V	-	-
C108	VCC_12V	Main Input Voltage	PWR 12V	-	-
C109	VCC_12V	Main Input Voltage	PWR 12V	-	-
C110	GND	Power Ground	PWR GND	-	-

Connector J1 Row D

Pin	Signal	Description	Type	Termination	Comment
D1	GND	Power Ground	PWR GND	-	-
D2	GND	Power Ground	PWR GND	-	-
D3	USB_SSTX0-	USB Super Speed Transmit Port 0 -	DP-O	-	-
D4	USB_SSTX0+	USB Super Speed Transmit Port 0 +	DP-O	-	-
D5	GND	Power Ground	PWR GND	-	-
D6	USB_SSTX1-	USB Super Speed Transmit Port 1 -	DP-O	-	-

D7	USB_SSTX1+	USB Super Speed Transmit Port 1 +	DP-O	-	-
D8	GND	Power Ground	PWR GND	-	-
D9	USB_SSTX2-	USB Super Speed Transmit Port 2 -	DP-O	-	-
D10	USB_SSTX2+	USB Super Speed Transmit Port 2+	DP-O	-	-
D11	GND	Power Ground	PWR GND	-	-
D12	USB_SSTX3-	USB Super Speed Transmit Port 3 -	DP-O	-	-
D13	USB_SSTX3+	USB Super Speed Transmit Port 3 +	DP-O	-	-
D14	GND	Power Ground	PWR GND	-	-
D15	DDI1_CTRLCLK_AUX+	Multiplexed DDI1 Data Channel Clock & AUX +	I/O-3.3	PD 100k	2k21 PU (S0) when DDI1_DDC_AUX_SEL is high
D16	DDI1_CTRLDATA_AUX-	Multiplexed DDI1 Data Channel Clock & AUX -	I/O-3.3	PU 100k (S0)	2k21 PU (S0) when DDI1_DDC_AUX_SEL is high
D17	RSVD	Reserved for future use	nc	-	-
D18	RSVD	Reserved for future use	nc	-	-
D19	PCIE_TX6+	PCI Express Lane 6 Transmit +	DP-O	-	-
D20	PCIE_TX6-	PCI Express Lane 6 Transmit -	DP-O	-	-
D21	GND	Power Ground	PWR GND	-	-
D22	PCIE_TX7+	PCI Express Lane 7 Transmit +	DP-O	-	-
D23	PCIE_TX7-	PCI Express Lane 7 Transmit -	DP-O	-	-
D24	RSVD	Reserved for future use	nc	-	-
D25	RSVD	Reserved for future use	nc	-	-
D26	DDI1_PAIR0+	DDI1 Pair 0 +	DP-O	-	-
D27	DDI1_PAIR0-	DDI1 Pair 0 -	DP-O	-	-
D28	RSVD	Reserved for future use	nc	-	-
D29	DDI1_PAIR1+	DDI1 Pair 1 +	DP-O	-	-
D30	DDI1_PAIR1-	DDI1 Pair 1 -	DP-O	-	-
D31	GND	Power Ground	PWR GND	-	-
D32	DDI1_PAIR2+	DDI1 Pair 2 +	DP-O	-	-
D33	DDI1_PAIR2-	DDI1 Pair 2 -	DP-O	-	-
D34	DDI1_DDC_AUX_SEL	DDI1 DDC/AUX Select	I-3.3	PD 1 MEG	-
D35	RSVD	Reserved for future use	nc	-	-
D36	DDI1_PAIR3+	DDI1 Pair 3 +	DP-O	-	-
D37	DDI1_PAIR3-	DDI1 Pair 3-	DP-O	-	-
D38	RSVD	Reserved for future use	nc	-	-
D39	DDI2_PAIR0+	DDI2 Pair 0 +	DP-O	-	-
D40	DDI2_PAIR0-	DDI2 Pair 0 -	DP-O	-	-
D41	GND	Power Ground	PWR GND	-	-
D42	DDI2_PAIR1+	DDI2 Pair 1 +	DP-O	-	-
D43	DDI2_PAIR1-	DDI2 Pair 1 -	DP-O	-	-
D44	DDI2_HPD	DDI2 Hotplug Detect	I-3.3	PD 100k	-
D45	RSVD	Reserved for future use	nc	-	-
D46	DDI2_PAIR2+	DDI2 Pair 2 +	DP-O	-	-
D47	DDI2_PAIR2-	DDI2 Pair 2 -	DP-O	-	-
D48	RSVD	Reserved for future use	nc	-	-
D49	DDI2_PAIR3+	DDI2 Pair 3 +	DP-O	-	-
D50	DDI2_PAIR3-	DDI2 Pair 3-	DP-O	-	-
D51	GND	Power Ground	PWR GND	-	-
D52	PEG_TX0+	PCI Express Graphics Lane 0 Transmit +	DP-O	-	-
D53	PEG_TX0-	PCI Express Graphics Lane 0 Transmit -	DP-O	-	-
D54	PEG_Lane_RV#	PCI Express Graphics Lane Reversal	I-3.3	PU 10k 3.3V (S0)	-
D55	PEG_TX1+	PCI Express Graphics Lane 1 Transmit +	DP-O	-	-

D56	PEG_TX1-	PCI Express Graphics Lane 1 Transmit -	DP-O	-	-
D57	TYPE2#	Connected to GND for TYPE 6 module	PWR GND	-	-
D58	PEG_TX2+	PCI Express Graphics Lane 2 Transmit +	DP-O	-	-
D59	PEG_TX2-	PCI Express Graphics Lane 2 Transmit -	DP-O	-	-
D60	GND	Power Ground	PWR GND	-	-
D61	PEG_TX3+	PCI Express Graphics Lane 3 Transmit +	DP-O	-	-
D62	PEG_TX3-	PCI Express Graphics Lane 3 Transmit -	DP-O	-	-
D63	RSVD	Reserved for future use	nc	-	-
D64	RSVD	Reserved for future use	nc	-	-
D65	PEG_TX4+	PCI Express Graphics Lane 4 Transmit +	DP-O	-	-
D66	PEG_TX4-	PCI Express Graphics Lane 4 Transmit -	DP-O	-	-
D67	GND	Power Ground	PWR GND	-	-
D68	PEG_TX5+	PCI Express Graphics Lane 5 Transmit +	DP-O	-	-
D69	PEG_TX5-	PCI Express Graphics Lane 5 Transmit -	DP-O	-	-
D70	GND	Power Ground	PWR GND	-	-
D71	PEG_TX6+	PCI Express Graphics Lane 6 Transmit +	DP-O	-	-
D72	PEG_TX6-	PCI Express Graphics Lane 6 Transmit -	DP-O	-	-
D73	GND	Power Ground	PWR GND	-	-
D74	PEG_TX7+	PCI Express Graphics Lane 7 Transmit +	DP-O	-	-
D75	PEG_TX7-	PCI Express Graphics Lane 7 Transmit -	DP-O	-	-
D76	GND	Power Ground	PWR GND	-	-
D77	RSVD	Reserved for future use	nc	-	-
D78	PEG_TX8+	PCI Express Graphics Lane 8 Transmit +	DP-O	-	-
D79	PEG_TX8-	PCI Express Graphics Lane 8 Transmit -	DP-O	-	-
D80	GND	Power Ground	PWR GND	-	-
D81	PEG_TX9+	PCI Express Graphics Lane 9 Transmit +	DP-O	-	-
D82	PEG_TX9-	PCI Express Graphics Lane 9 Transmit -	DP-O	-	-
D83	RSVD	Reserved for future use	nc	-	-
D84	GND	Power Ground	PWR GND	-	-
D85	PEG_TX10+	PCI Express Graphics Lane 10 Transmit +	DP-O	-	-
D86	PEG_TX10-	PCI Express Graphics Lane 10 Transmit -	DP-O	-	-
D87	GND	Power Ground	PWR GND	-	-
D88	PEG_TX11+	PCI Express Graphics Lane 11 Transmit +	DP-O	-	-
D89	PEG_TX11-	PCI Express Graphics Lane 11 Transmit -	DP-O	-	-
D90	GND	Power Ground	PWR GND	-	-
D91	PEG_TX12+	PCI Express Graphics Lane 12 Transmit +	DP-O	-	-
D92	PEG_TX12-	PCI Express Graphics Lane 12 Transmit -	DP-O	-	-
D93	GND	Power Ground	PWR GND	-	-
D94	PEG_TX13+	PCI Express Graphics Lane 13 Transmit +	DP-O	-	-
D95	PEG_TX13-	PCI Express Graphics Lane 13 Transmit -	DP-O	-	-
D96	GND	Power Ground	PWR GND	-	-
D97	RSVD	Reserved for future use	nc	-	-
D98	PEG_TX14+	PCI Express Graphics Lane 14 Transmit +	DP-O	-	-
D99	PEG_TX14-	PCI Express Graphics Lane 14 Transmit -	DP-O	-	-
D100	GND	Power Ground	PWR GND	-	-
D101	PEG_TX15+	PCI Express Graphics Lane 15 Transmit +	DP-O	-	-
D102	PEG_TX15-	PCI Express Graphics Lane 15 Transmit -	DP-O	-	-
D103	GND	Power Ground	PWR GND	-	-
D104	VCC_12V	Main Input Voltage	PWR 12V	-	-
D105	VCC_12V	Main Input Voltage	PWR 12V	-	-
D106	VCC_12V	Main Input Voltage	PWR 12V	-	-

D107	VCC_12V	Main Input Voltage	PWR 12V	-	-
D108	VCC_12V	Main Input Voltage	PWR 12V	-	-
D109	VCC_12V	Main Input Voltage	PWR 12V	-	-
D110	GND	Power Ground	PWR GND	-	-

Mechanical Specification

PCB Dimensions

- Basic - 125 mm x 95 mm

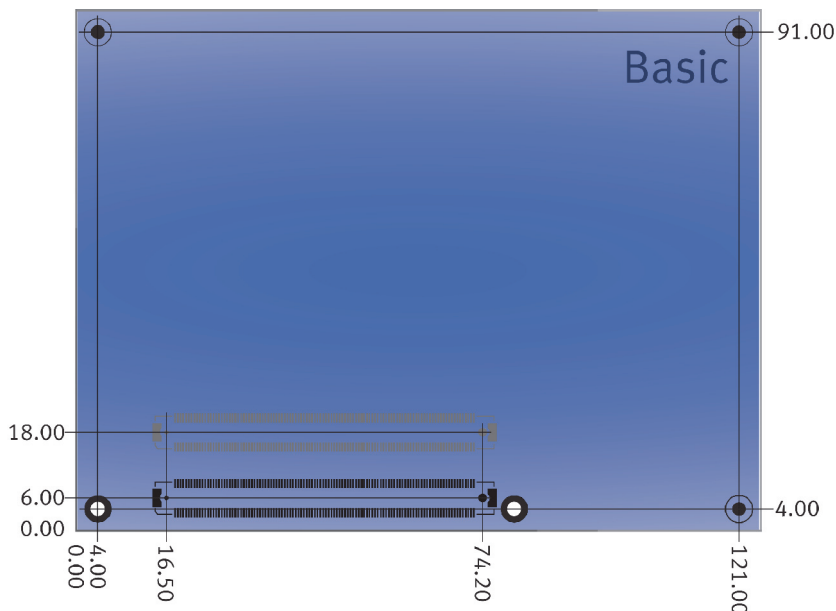

All dimensions are shown in millimeters.

- Two defined heights:
 - 18 mm (5 mm carrier connector)
 - 21 mm (8 mm carrier connector)

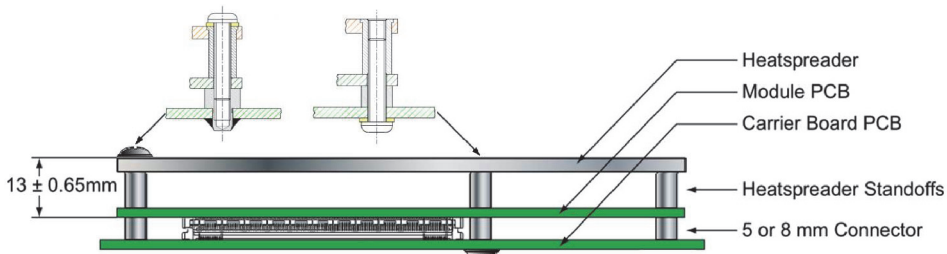

Cooling Solution

DATA MODUL provides an active cooling solution with fan and a passive cooling solution without fan.

Assembly Heatspreader Dimensions

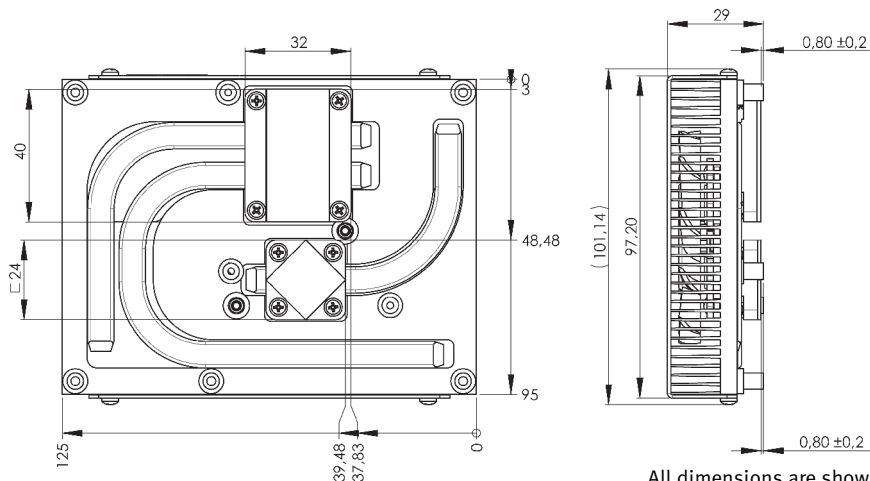

All dimensions are shown in millimeters.

Mechanical & Thermal Considerations

The eDM-COMB-SL6 is designed to operate within a temperature range of 0°C to 60°C.

An important factor for each system integration is the thermal design. The assembly heatspreader acts as thermal coupling device to the module. The assembly heatspreader is thermally coupled to the CPU and other heat generating components via a fan or heat pipe. Although the assembly heatspreader is the thermal interface where most of the heat generated by the module is dissipated, it is not be considered as a heatsink. It has been designed to be used as thermal interface between the module and the application thermal solution. The application specific thermal solution may use heatsinks with fans, and heat pipes.



Do not operate the eDM-COMB-SL6 without properly attached assembly heatspreader (cooling solution).

Standard Cooling Solution with Fan

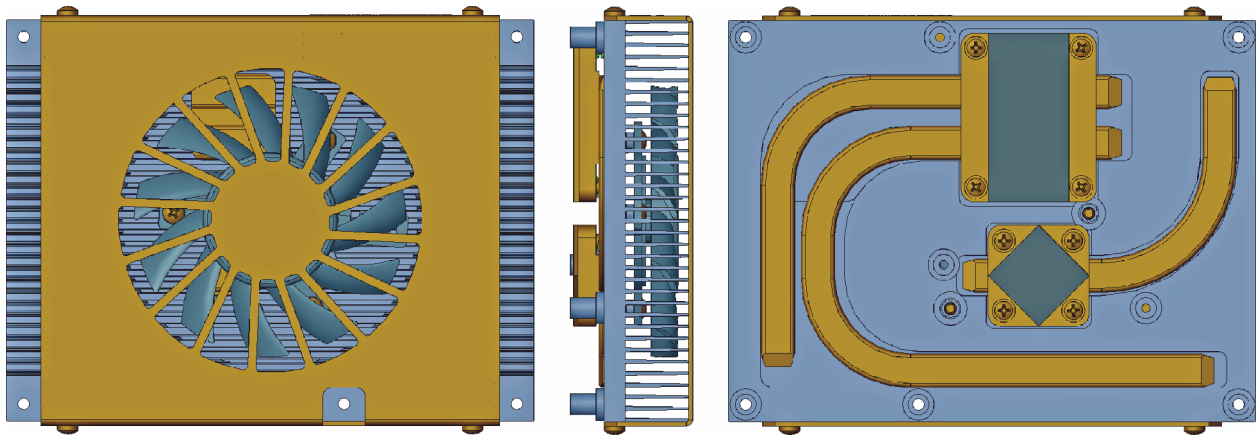

Standard Cooling Solution passive

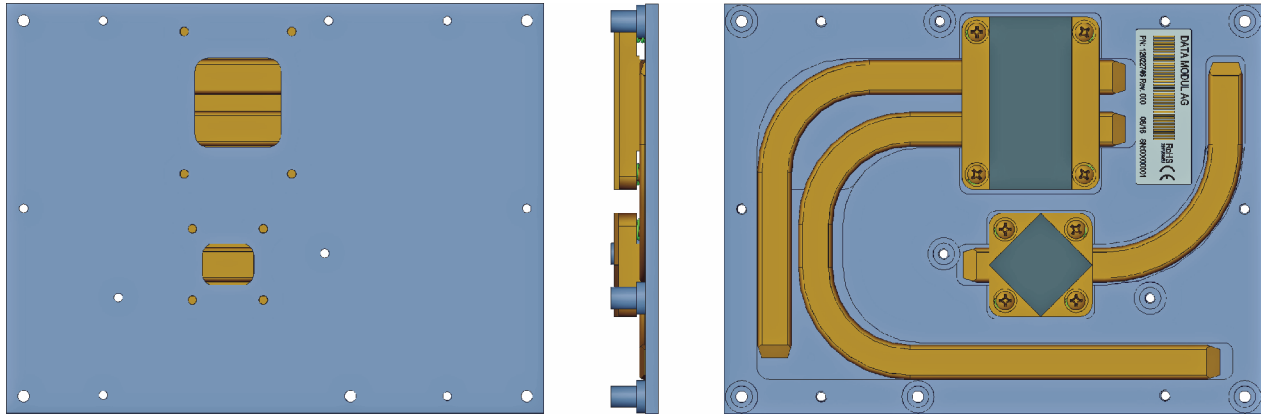

Standard Heatspreader

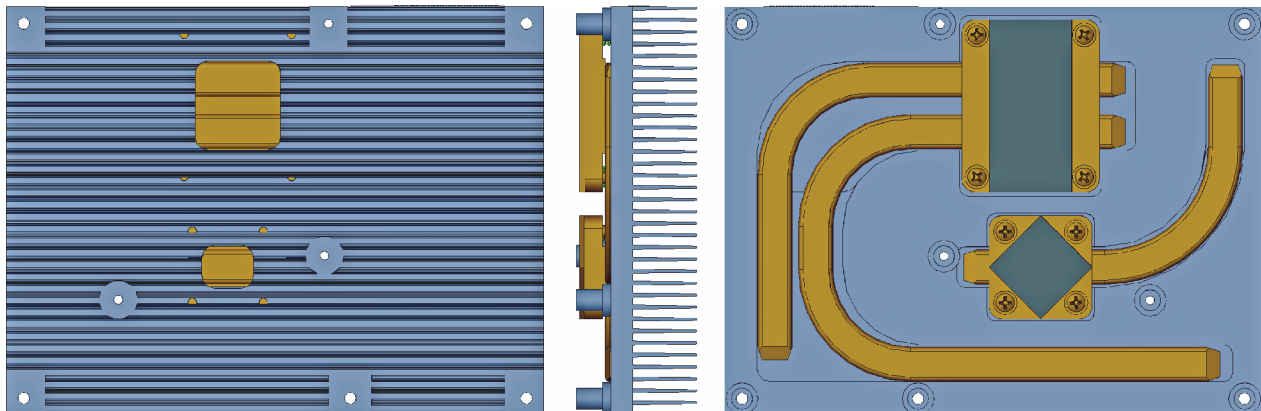

BIOS Setup

The purpose of this chapter is to describe the settings in the UEFI BIOS Setup program on this Computer on Module and to explain the procedure for updating the UEFI BIOS.

Terms & Abbreviations

Term	Description
ACPI	Advanced Configuration and Power Interface
AES	Advanced Encryption Standard
AFU	AMI Firmware Update
ASPM	Active State Power Management
BBS	BIOS Boot Specification
COM	Computer On Module
CRID	Compatible Revision ID
CSM	Compatibility Support Module
CTDP	Configurable TDP
DMI	Direct Memory Interface
DTS	Digital Thermal Sensor
DVMT	Dynamic Video Memory Technology
ECP	Enhanced Capabilities Port
EFP	External Flat Panel
EHCI	Enhanced Host Controller Interface
EIS	Enhanced Intel Speedstep
EPP	Enhanced Parallel Port
IGFX	Intel Graphics
IPv4/IPv6	Intel Protocol Version
KEK	Key Exchange Key
LBAR	Linear Base Address Register
LFP	Local Flat Panel
MRC	Memory Reference Code
NMI	Non-Maskable Interrupt
NVRAM	Non-Volatile Random-Access Memory
OPROM	Option ROM
OS	Operating System
PK	Platform Key
PME	Power Management Event
PWM	Pulse Width Modulation
PXE	Preboot Execution Environment
RAID	Redundant Array of Independent Disk
SCI	System Control Interrupt
SMI	System Management Interrupt
SO-DIMM	Small Outline Dual Inline Memory Module
SPP	Standard Parallel Port
TDP	Thermal Design Power
TOLUD	Top Of Lower Usable Memory
TXT	Trusted Execution Technology
VT-d	Virtualization Technology for Directed I/O
WDT	Watchdog Timeout
XHCI	eXtensible Host Controller Interface

BIOS Update Description

This COM is provided with an American Megatrends, Inc. Aptio V UEFI Firmware. Please use the AMI Firmware Update (AFU) utility suite for updating the BIOS. This is a scriptable command line tool, utilized for factory or field BIOS updates. It is available for DOS, Microsoft Windows®, Linux, FreeBSD and the UEFI shell.

Please contact your DATA MODUL support for accessing the tools.

The complete UEFI Firmware image for this eDM-COM Board consists of the following parts:

- Main BIOS: Responsible for main hardware initialization and feature interfaces during runtime.
- Boot Block: Minimal hardware initialization and provides recovery functionality.
- NVRAM: Stores configuration variables.
- Management Engine: Intel® ME firmware binary.
- GbE Region: Stores Gigabit-Ethernet configuration data.

For updating the complete 16MB firmware image with the UEFI version of AFU use following command:

- `afuefix64.efi newbiosfile.bin /P /B /N /ME /X.`

BIOS Setup Description

The UEFI Setup program allows users to modify the basic system configuration and save these settings to NVRAM.

To enter UEFI Setup, press DEL or ESC during POST.



To select a Boot Popup Menu, press F7 during POST. At End of Post a selection menu will show all available boot devices to choose from. UEFI Setup program can be entered from Boot Popup Menu as well.



Following is a description of the UEFI Setup pages.

Main

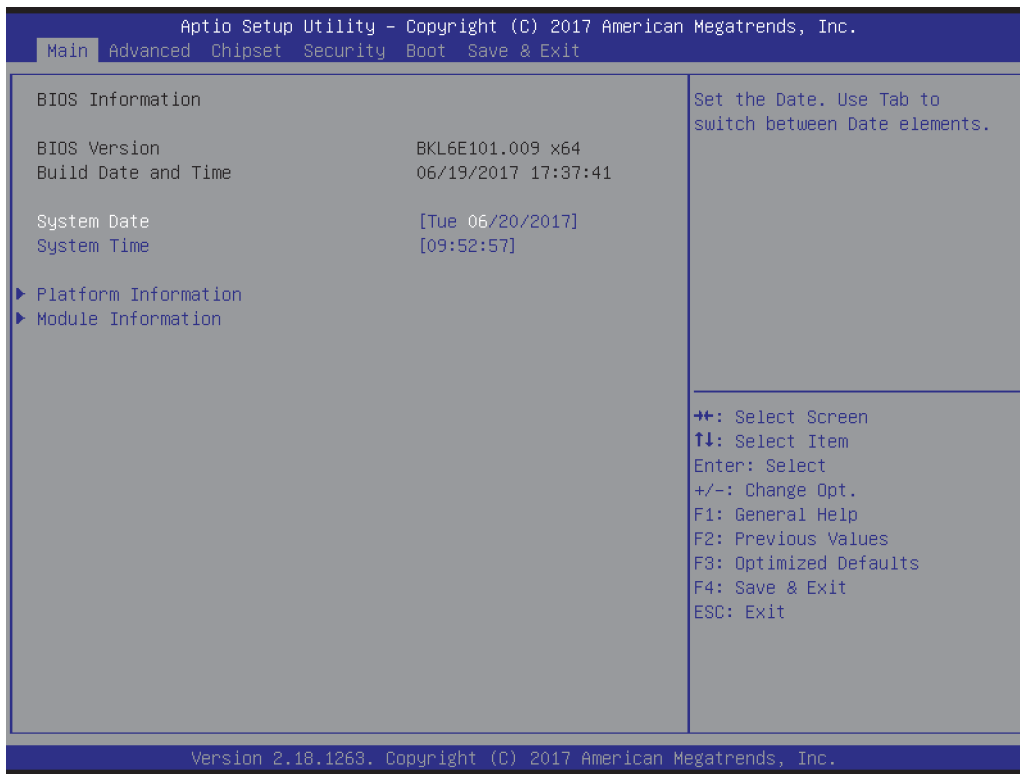

Parameter	Value	Comment
System Date	Day MM/DD/YYYY	Set the Date.
System Time	HH:MM:SS	Set the Time.
Platform Information	Submenu	Displays Platform Information.
Module Information	Submenu	Displays Module Information.

Platform Information

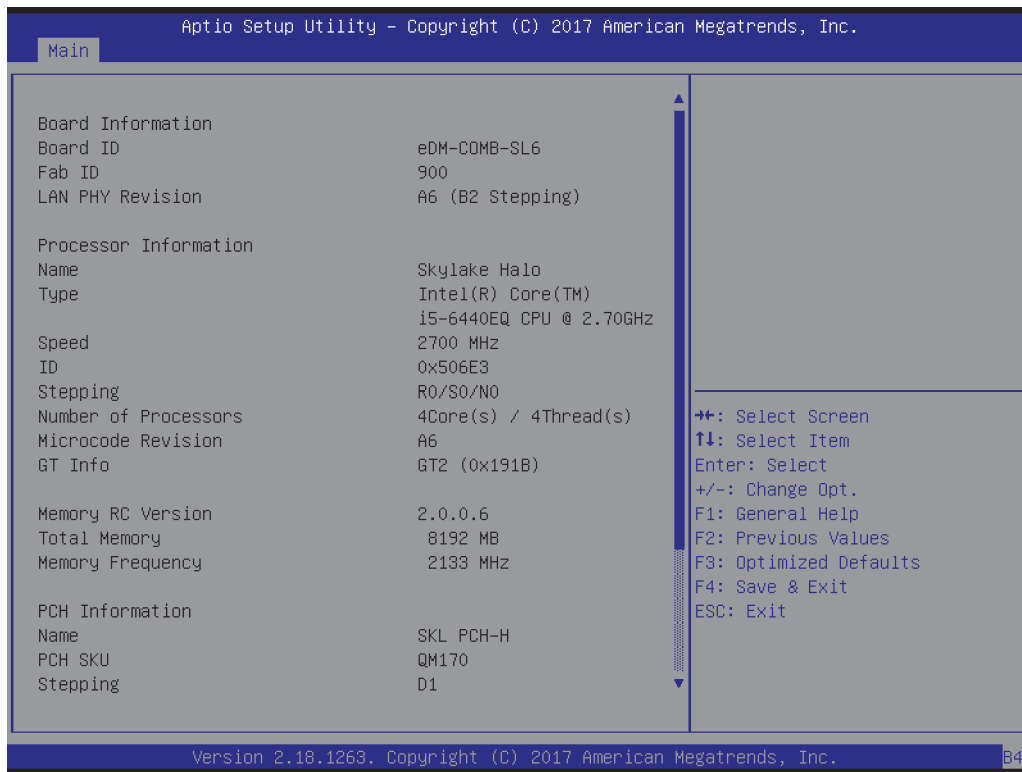

Module Information

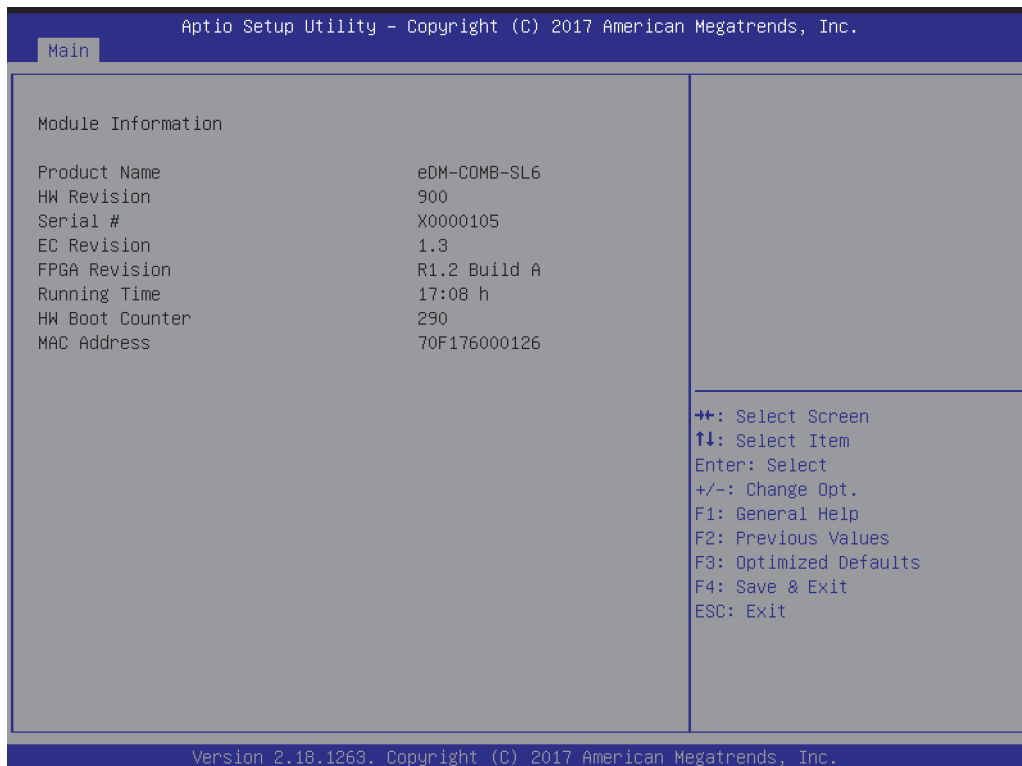

Advanced

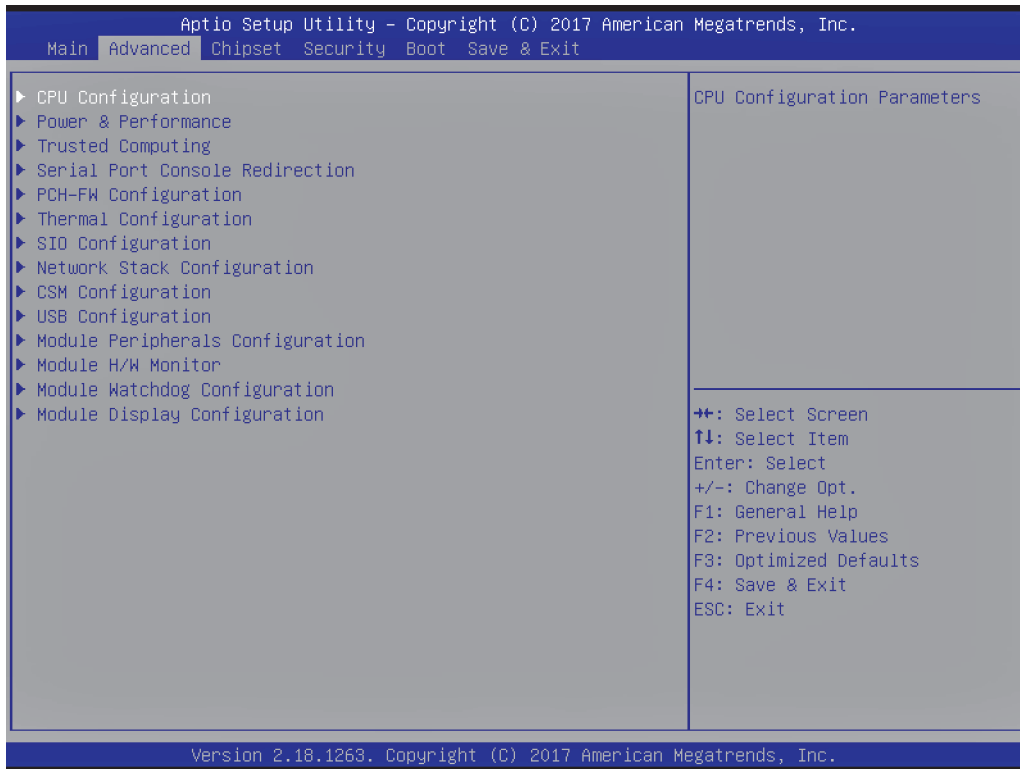

Parameter	Value	Comment
CPU Configuration	Submenu	CPU Configuration Parameters
Power & Performance	Submenu	Power & Performance Options
Trusted Computing	Submenu	Trusted Computing (TPM) Settings
Serial Port Console Redirection	Submenu	Serial Port Console Redirection Settings
PCH-FW Configuration	Submenu	Configure Management Engine Parameters
Thermal Configuration	Submenu	Thermal Configuration Parameters
SIO Configuration	Submenu	SuperIO Settings
Network Stack Configuration	Submenu	Network Stack Settings
CSM Configuration	Submenu	Compatibility Support Module Settings
USB Configuration	Submenu	USB Configuration Parameters
Module Peripherals Configuration	Submenu	Configure Module Peripherals
Module H/W Monitor	Submenu	Monitor hardware status
Module Watchdog Configuration	Submenu	Configure Watchdog
Module Display Configuration	Submenu	Configure Module Display options

CPU Configuration

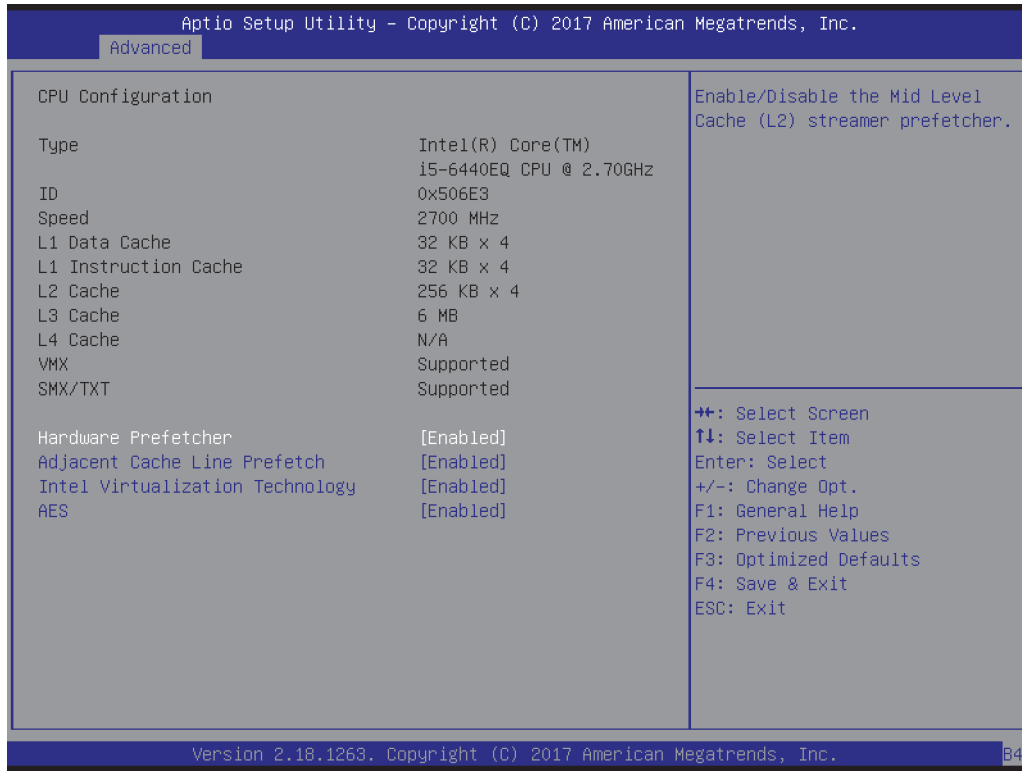

Parameter	Value	Comment
Hardware Prefetcher	Enabled Disabled	Enable/Disable the Mid Level Cache (L2) streamer prefetcher.
Adjacent Cache Line Prefetch	Enabled Disabled	Enable/Disable the Mid Level Cache (L2) prefetching of adjacent cache lines.
Intel Virtualization Technology	Enabled Disabled	When enabled, a VMM can utilize the additional hardware capabilities provided by Vanderpool Technology.
AES	Enabled Disabled	Enable/Disable CPU Advanced Encryption Standard instructions.

Power & Performance

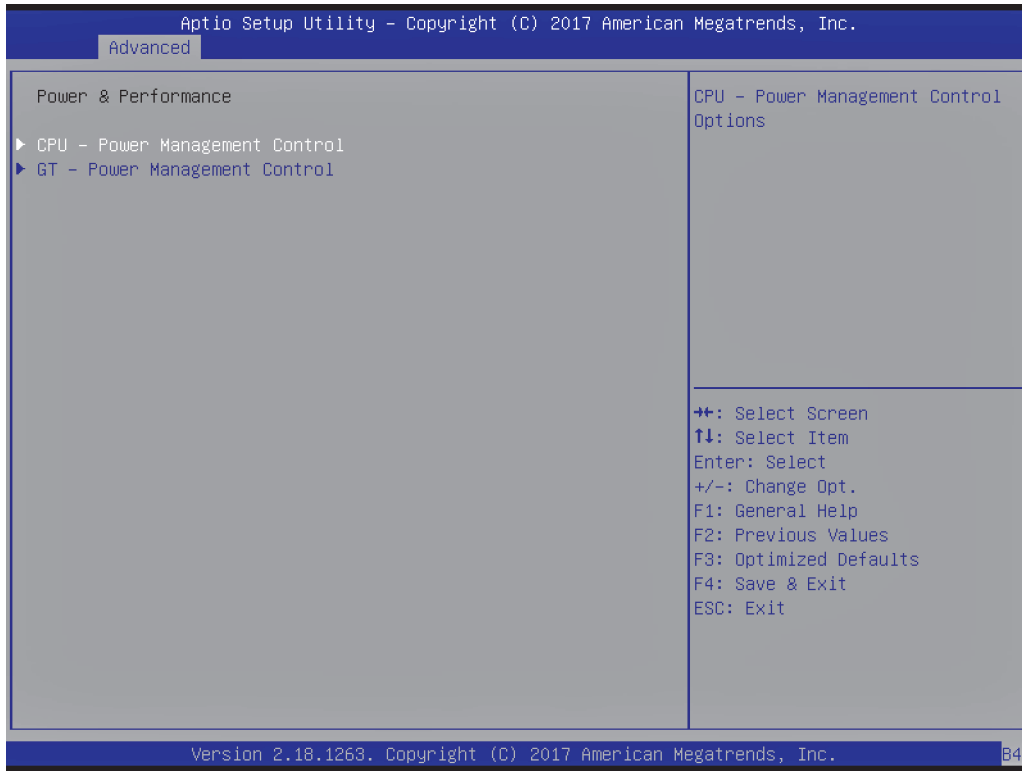

Parameter	Value	Comment
CPU – Power Management Control	Submenu	CPU – Power Management Control Options
GT – Power Management Control	Submenu	GT – Power Management Control Options

CPU - Power Management Control

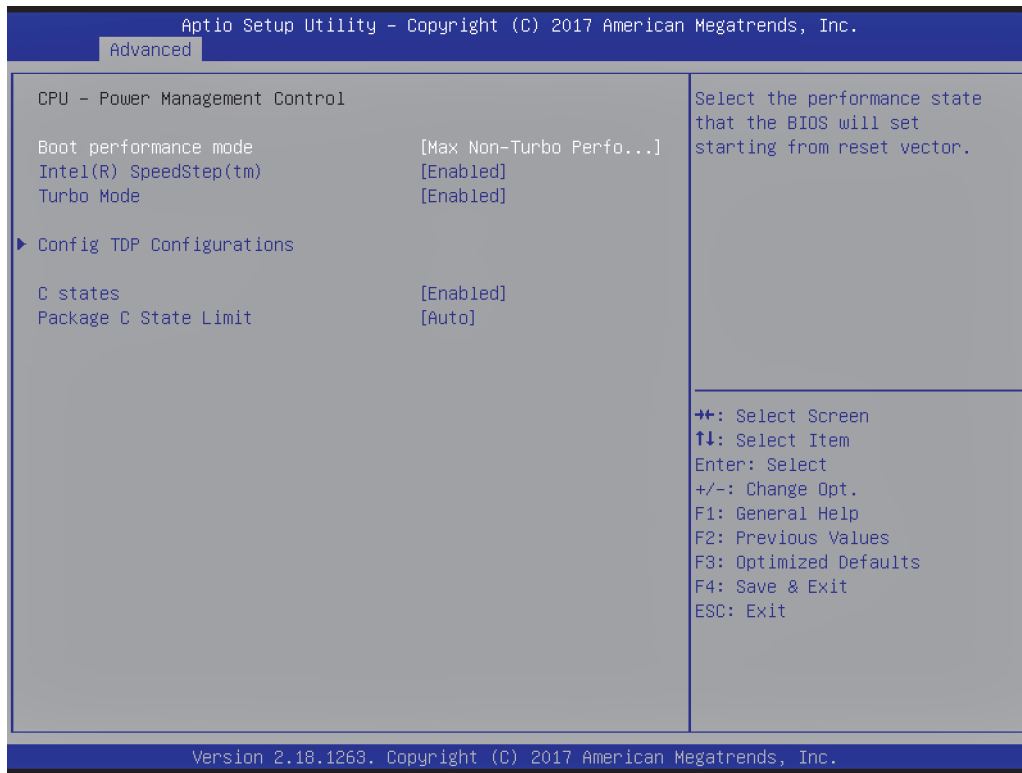

Parameter	Value	Comment
Boot performance mode	Max Non-Turbo Performance Max Battery Turbo Performance	Select the performance state that the BIOS will set starting from reset vector.
Intel(R) SpeedStep(tm)	Enabled Disabled	Enable/Disable Intel SpeedStep Technology.
Turbo Mode	Enabled Disabled	Enable/Disable Intel Turbo Boost Technology.
Config TDP Configurations	Submenu	Config TDP Configurations
C states	Enabled Disabled	Enable/Disable CPU Power Management. Allows CPU to go to C states when it's not 100% utilized.
Package C State Limit	Auto Cpu Default C10 C9 C8 C7S C7 C6 C3 C2 C0/C1	Maximum Package C State Limit Setting. Cpu Default: Leaves to Factory default value. Auto: Initializes to deepest available Package C State Limit.

Config TDP Configuration

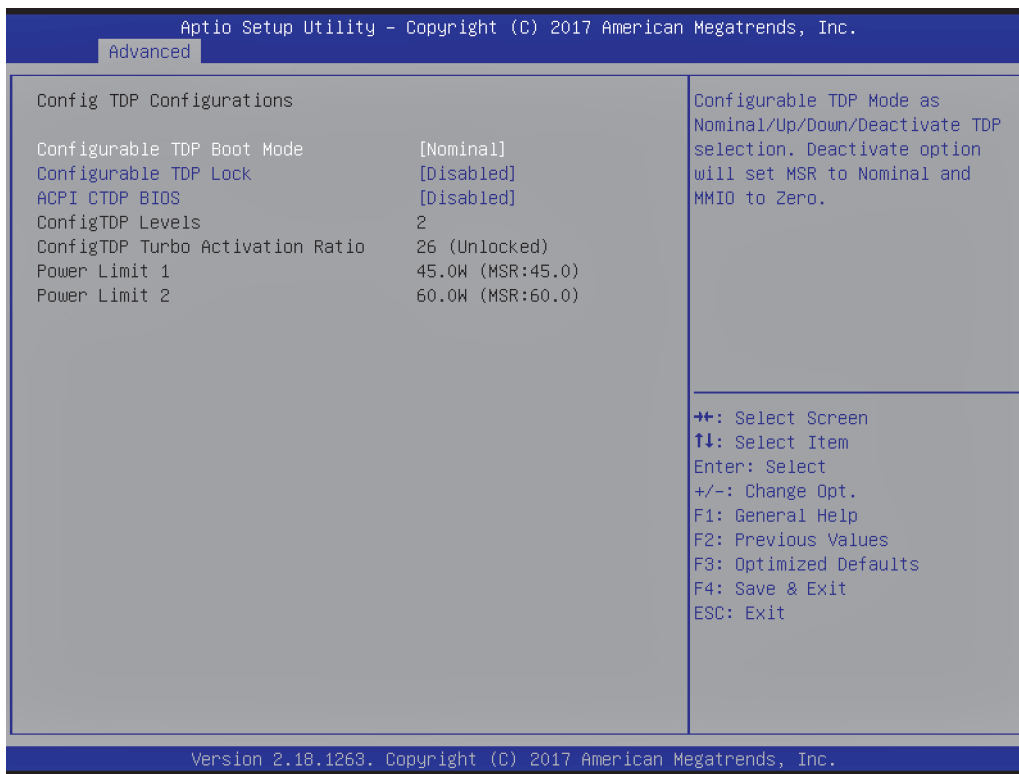

Parameter	Value	Comment
Configurable TDP Boot Mode	Nominal Down Up Deactivated	Configurable TDP Mode as Nominal/Up/Down/Deactivate TDP selection. Deactivate option will set MSR to Nominal and MMIO to Zero.
Configurable TDP Lock	Enabled Disabled	Configurable TDP Mode Lock sets the Lock bits on TURBO_ACTIVATION_RATIO and CONFIG_TDP_CONTROL. Note: When CTDp Lock is enabled Custom ConfigTDP Count will be forced to 1 and Custom ConfigTDP Boot Index will be forced to 0.
ACPI CTDp BIOS	Enabled Disabled	Enable/Disable ACPI Configurable TDP support (TableId CtdpB).

GT - Power Management Control

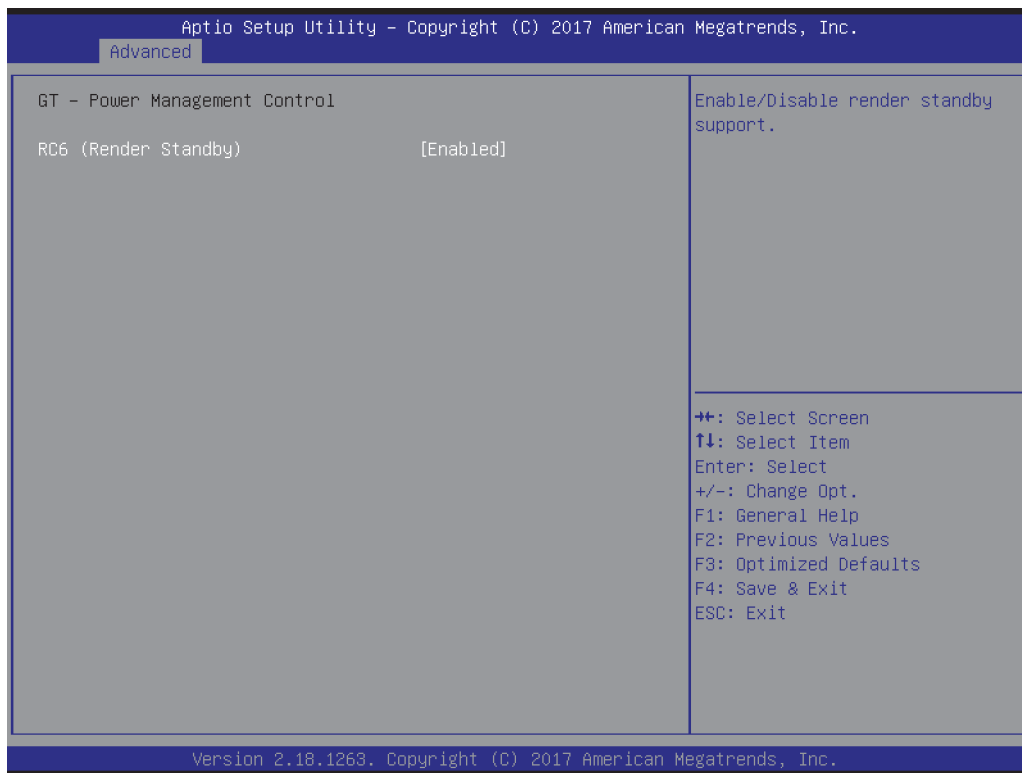

Parameter	Value	Comment
RC6 (Render Standby)	Enabled Disabled	Enable/Disable render standby support.

Trusted Computing

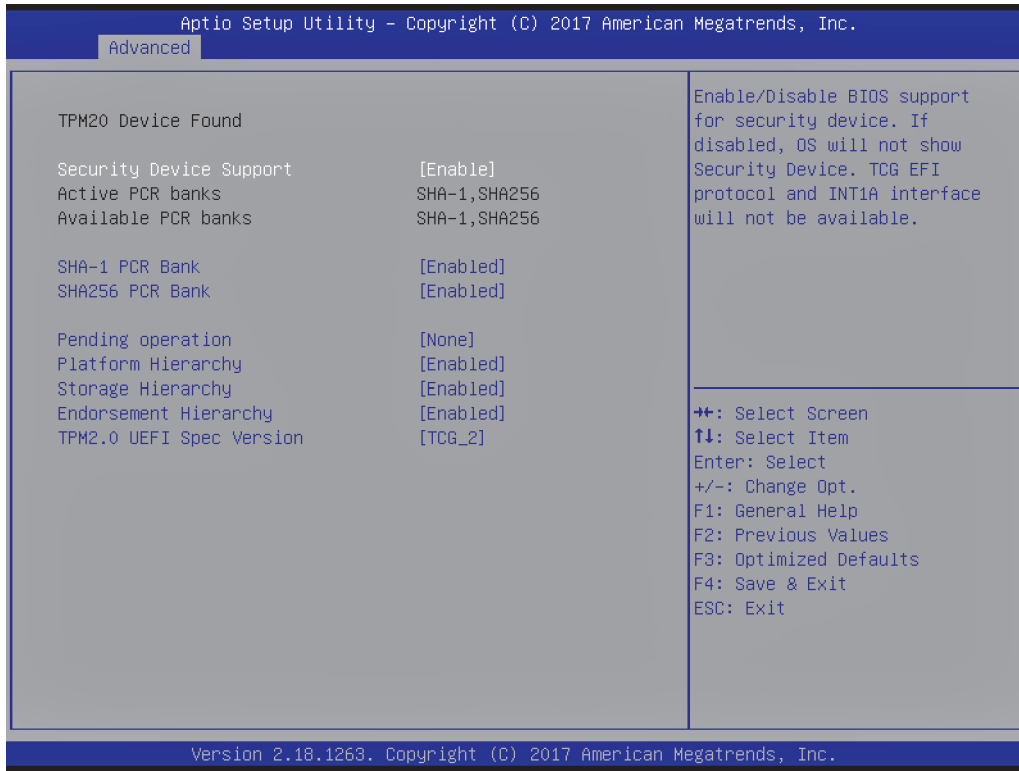

Parameter	Value	Comment
Security Device Support	Enabled Disabled	Enable/Disable BIOS support for security device. If disabled, OS will not show Security Device. TCG EFI protocol and INT1A interface will not be available.
SHA-1 PCR Bank	Enabled Disabled	Enable or Disable SHA-1 PCR Bank.
SHA256 PCR Bank	Enabled Disabled	Enable or Disable SHA256 PCR Bank.
Pending operation	None TPM Clear	Schedule an Operation for the Security Device. NOTE: Your Computer will reboot during restart in order to change State of Security Device.
Platform Hierarchy	Enabled Disabled	Enable or Disable Platform Hierarchy.
Storage Hierarchy	Enabled Disabled	Enable or Disable Storage Hierarchy.
Endorsement Hierarchy	Enabled Disabled	Enable or Disable Endorsement Hierarchy.
TPM2.0 UEFI Spec Version	TCG_1_2 TCG_2	Select the TCG2 Spec Version Support. TCG_1_2: the Compatible mode for Win8/Win10. TCG_2: Support new TCG2 protocol and event format for Win10 or later.

Serial Port Console Redirection

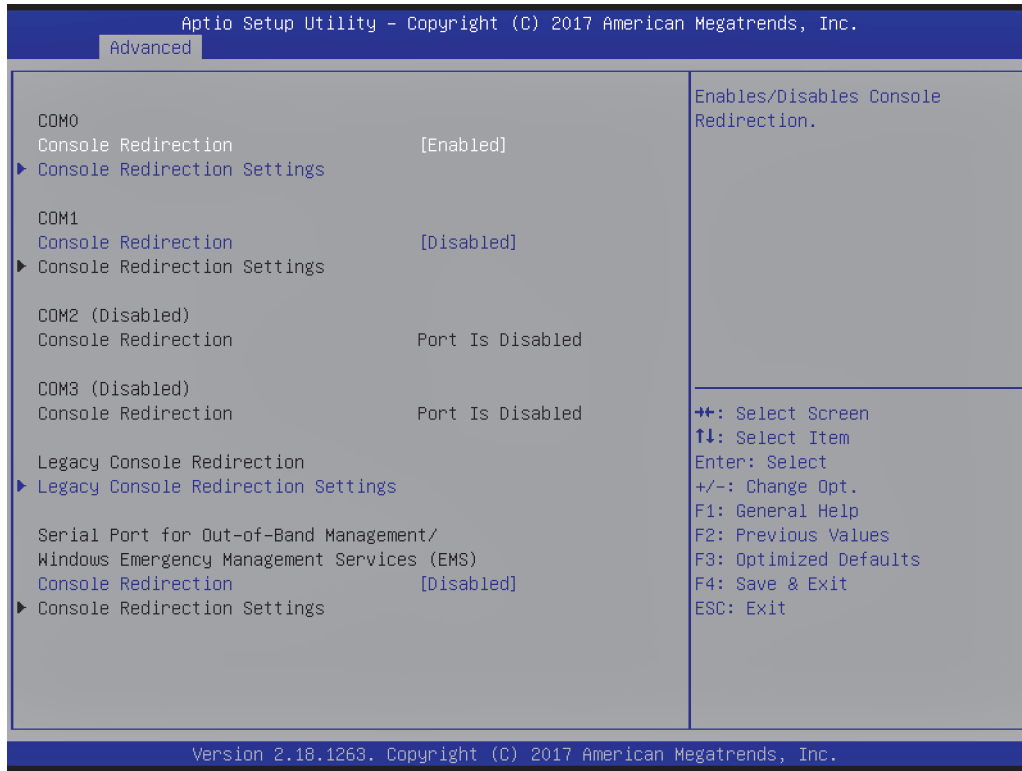

Parameter	Value	Comment
Console Redirection	Enabled Disabled	Enables/Disables Console Redirection.
Console Redirection Settings	Submenu	The settings specify how the host computer and the remote computer (which the user is using) will exchange data. Both computers should have the same or compatible settings.
Legacy Console Redirection Settings	Submenu	Configure Port for Legacy Console Redirection.

Console Redirection Settings

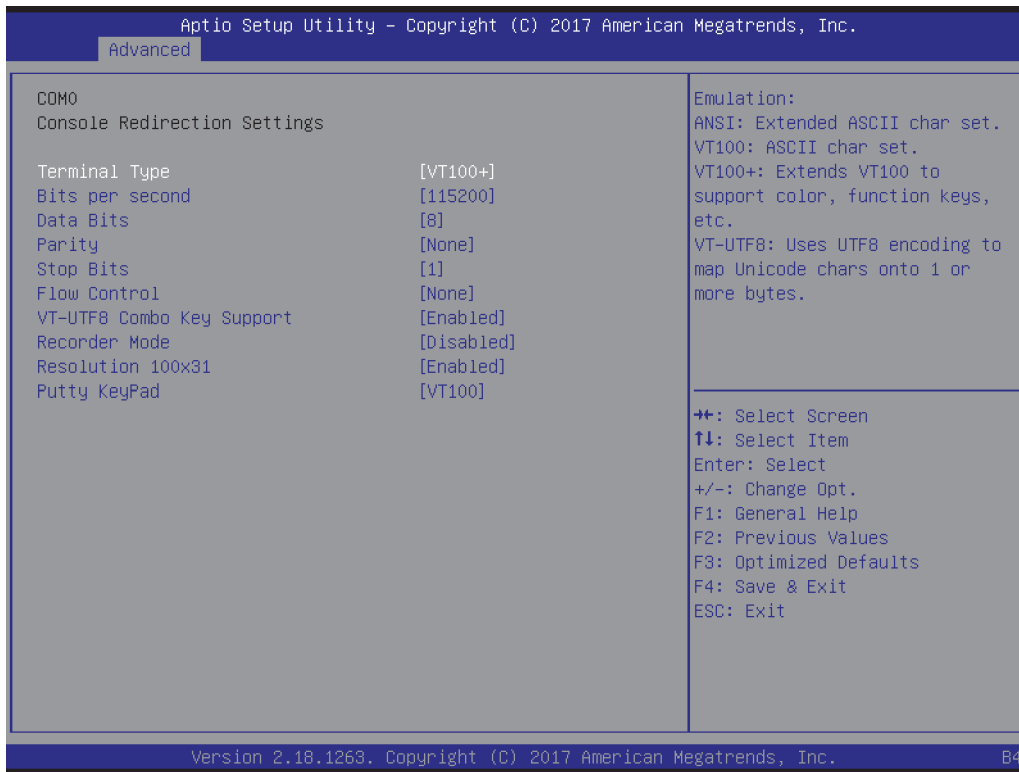

Parameter	Value	Comment
Terminal Type	VT100 VT100+ VT-UTF8 ANSI	Emulation: ANSI: Extended ASCII char set. VT100: ASCII char set. VT100+: Extends VT100 to support color, function keys, etc. VT-UTF8: Uses UTF8 encoding to map Unicode chars onto 1 or more bytes.
Bits per second	9600 19200 38400 57600 115200	Selects serial port transmission speed. The speed must be matched on the other side. Long or noisy lines may require lower speeds.
Data Bits	7 8	Configures the number of data bits. 8 is recommended to easily use the link for file transfer and non-English text transfer.
Parity	None Even Odd Mark Space	A parity bit can be sent with the data bits to detect some transmission errors. Even: parity bit is 0 if the num of 1's in the data bits is even. Odd: parity bit is 0 if num of 1's in the data bits is odd. Mark: parity bit is always 1. Space: Parity bit is always 0. Mark and Space Parity do not allow for error detection. They can be used as an additional data bit.
Stop Bits	1 2	Stop bits indicate the end of a serial data packet. (A start bit indicates the beginning). The standard setting is 1 stop bit. Communication with slow devices may require more than 1 stop bit.
Flow Control	None Hardware RTS/CTS	Flow control can prevent data loss from buffer overflow. When sending data, if the receiving buffers are full, a 'stop' signal can be sent to stop the data flow. Once the buffers are empty, a 'start' signal can be sent to re-start the flow. Hardware flow control uses two wires to send start/stop signals.
VT-UTF8 Combo Key Support	Enabled Disabled	Enable: VT-UTF8 Combination Key Support for ANSI/VT100 terminals.
Recorder Mode	Enabled Disabled	With this mode enabled, only text will be sent. This is to capture Terminal data.
Resolution 100x31	Enabled Disabled	Enables/Disables extended terminal resolution.

Parameter	Value	Comment
Putty KeyPad	VT100 LINUX XTERMR6 SCO ESCN VT400	Select FunctionKey and KeyPad on Putty.
Redirection After BIOS POST	Enabled Disabled	Enabled: Console Redirection is available for Legacy OS. Disabled: Legacy console redirection is disabled before booting to Legacy OS.

Legacy Console Redirection Settings

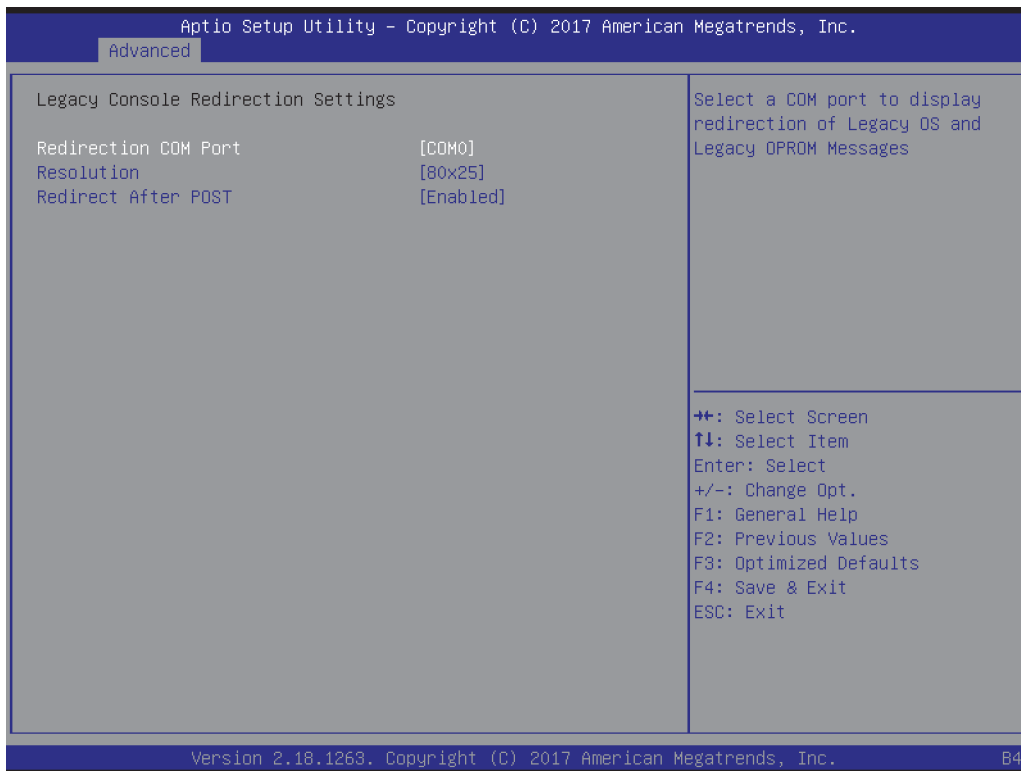

Parameter	Value	Comment
Redirection COM Port	COM0 COM1 COM2 COM3	Select a COM Port to use for Legacy OS and Legacy OPROM Console Redirection.
Resolution	80x24 80x25	On Legacy OS, the Number of Rows and Columns supported by redirection.
Redirection After POST	Enabled Disabled	Enabled: Console Redirection is available for Legacy OS. Disabled: Legacy console redirection is disabled before booting to Legacy OS.

Serial Port for Out-of-Band Management/Windows Emergency Management Services (EMS)

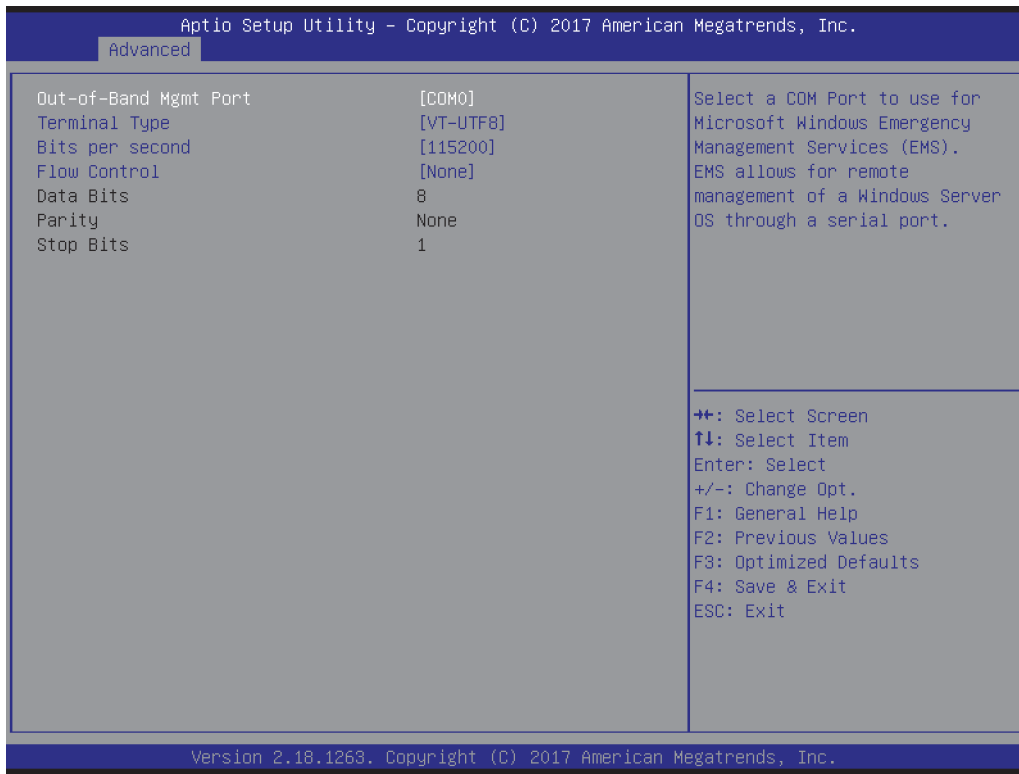

Parameter	Value	Comment
Out-Of-Band Mgmt Port	COM0 COM1 COM2 COM3	Select a COM Port to use for Microsoft Windows Emergency Management Services (EMS). EMS allows for remote management of a Windows Server OS through a serial port.
Terminal Type	VT100 VT100+ VT-UTF8 ANSI	VT-UTF8 is the preferred terminal type for out-of-band management. The next best choice is VT100+ and then VT100. See above, in Console Redirection Settings page, for more Help with Terminal Type/Emulation.
Bits per second	9600 19200 57600 115200	Selects serial port transmission speed. The speed must be matched on the other side. Long or noisy lines may require lower speeds.
Flow Control	None Hardware RTS/CTS Software Xon/Xoff	Flow control can prevent data loss from buffer overflow. When sending data, if the receiving buffers are full, a 'stop' signal can be sent to stop the data flow. Once the buffers are empty, a 'start' signal can be sent to re-start the flow. Hardware flow control uses two wires to send start/stop signals.

Thermal Configuration

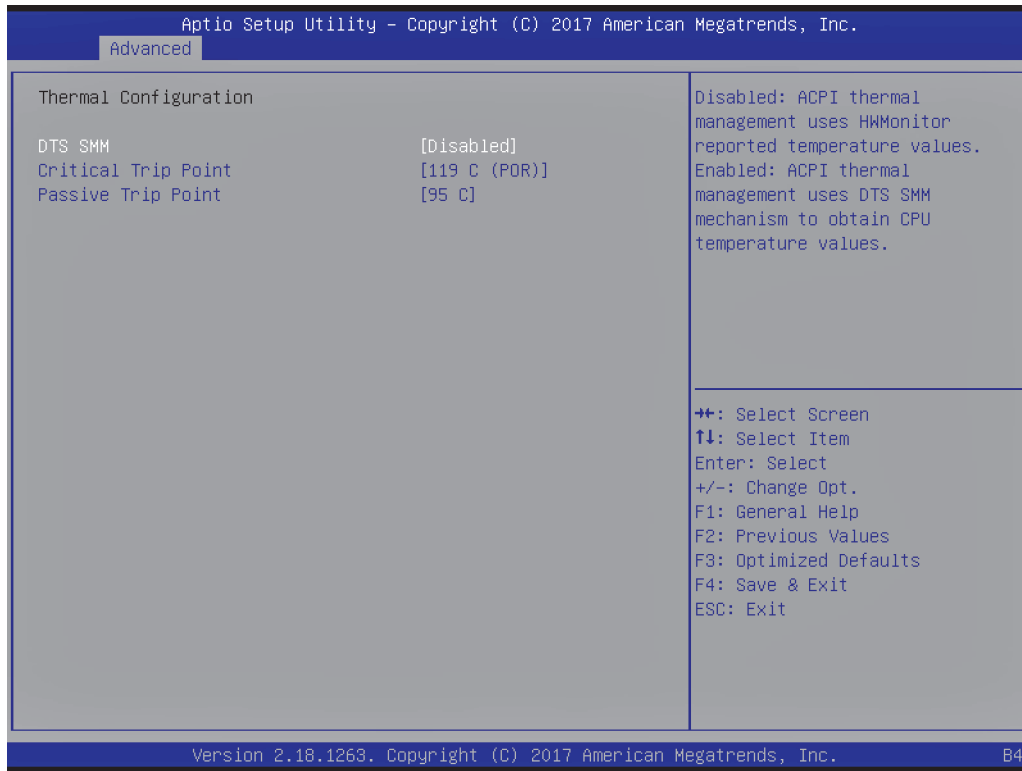

Parameter	Value	Comment
DTS SMM	Enabled Disabled	Disabled: ACPI thermal management uses HWMonitor reported temperature values. Enabled: ACPI thermal management uses DTS SMM mechanism to obtain CPU temperature values.
Critical Trip Point	127 C 119 C (POR) 111 C 103 C 100 C 95 C 87 C 79 C 71 C 63 C	This value controls the temperature of the ACPI Critical Trip Point - the point at which the OS will shut the system off. NOTE: 119C is the Plan Of Record (POR) for all Intel mobile processors.
Passive Trip Point	95 C 87 C 79 C 71 C 63 C 55 C 47 C 39 C Disabled	This value controls the temperature of the ACPI Passive Trip Point - the point at which the OS will begin throttling the processor.

SIO Configuration

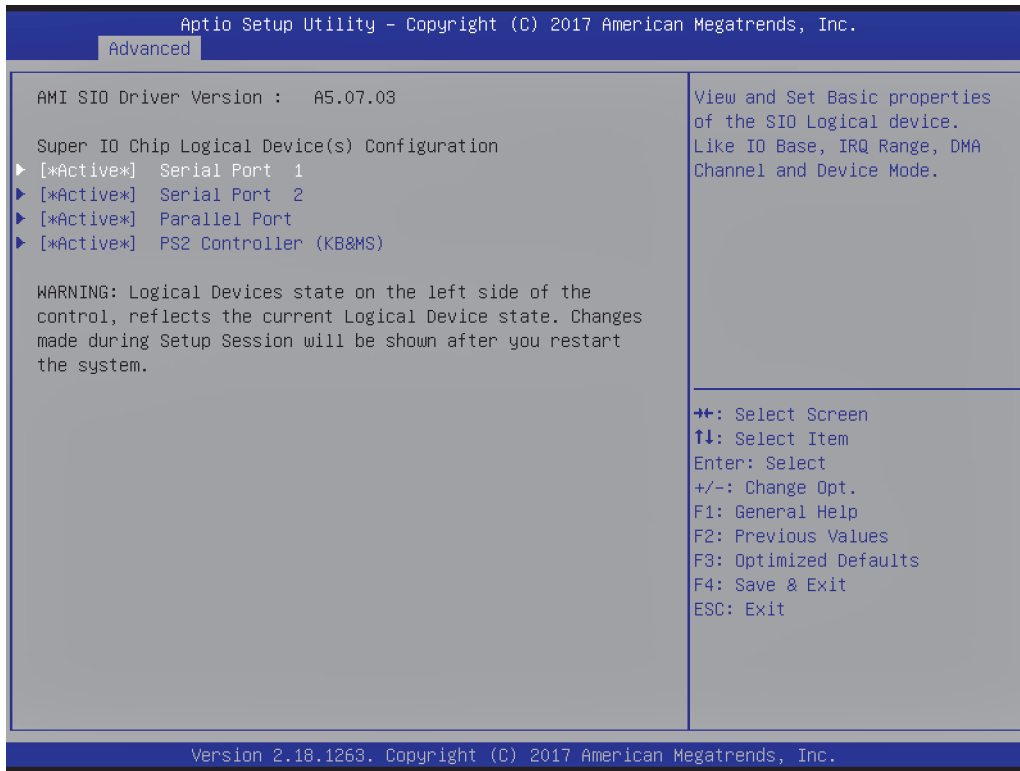

Parameter	Value	Comment
Serial Port 1	Submenu	View and set basic properties of the SIO logical device. Like IO base, IRQ range, DMA channel and device mode.
Serial Port 2	Submenu	
Parallel Port	Submenu	
PS2 Controller (KB&MS)	Submenu	

Serial Port 1 Configuration

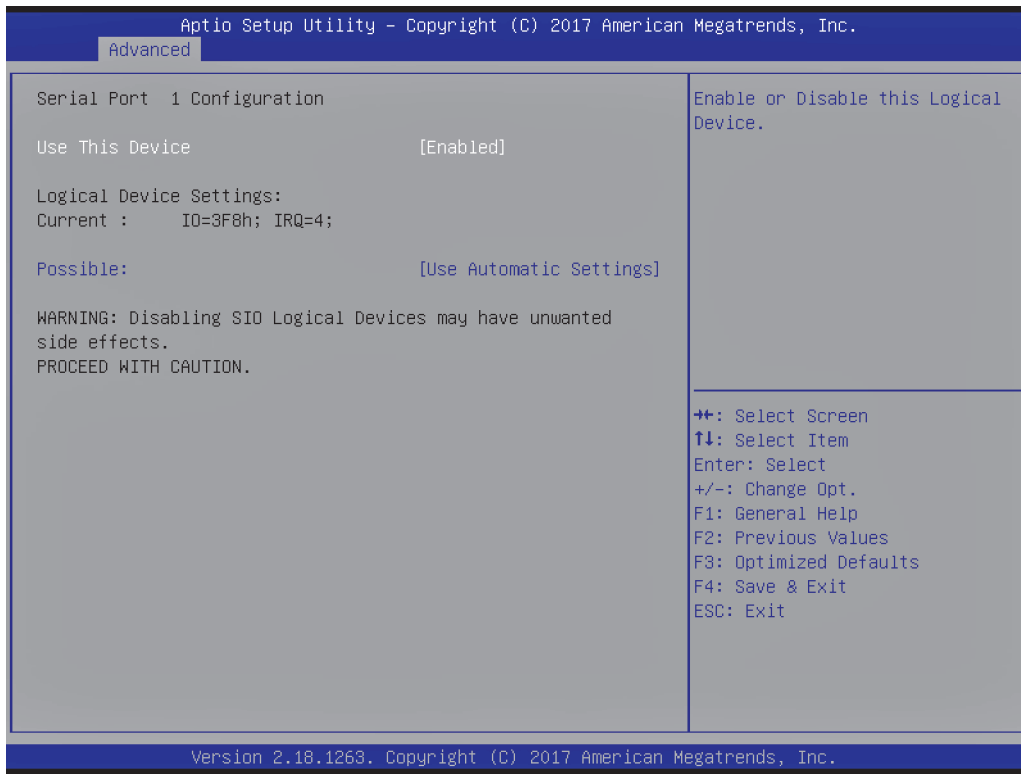

Parameter	Value	Comment
Use This Device	Enabled Disabled	Enable or Disable this Logical Device.
Possible	Use Automatic Settings IO=3F8h; IRQ=4 IO=2F8h IO=3E8h IO=2E8h IRQ=3,4,5,7,9,10,11,12	Configure Device's Resource settings. New settings will be reflected on This Setup Page after System restarts.

Serial Port 2 Configuration

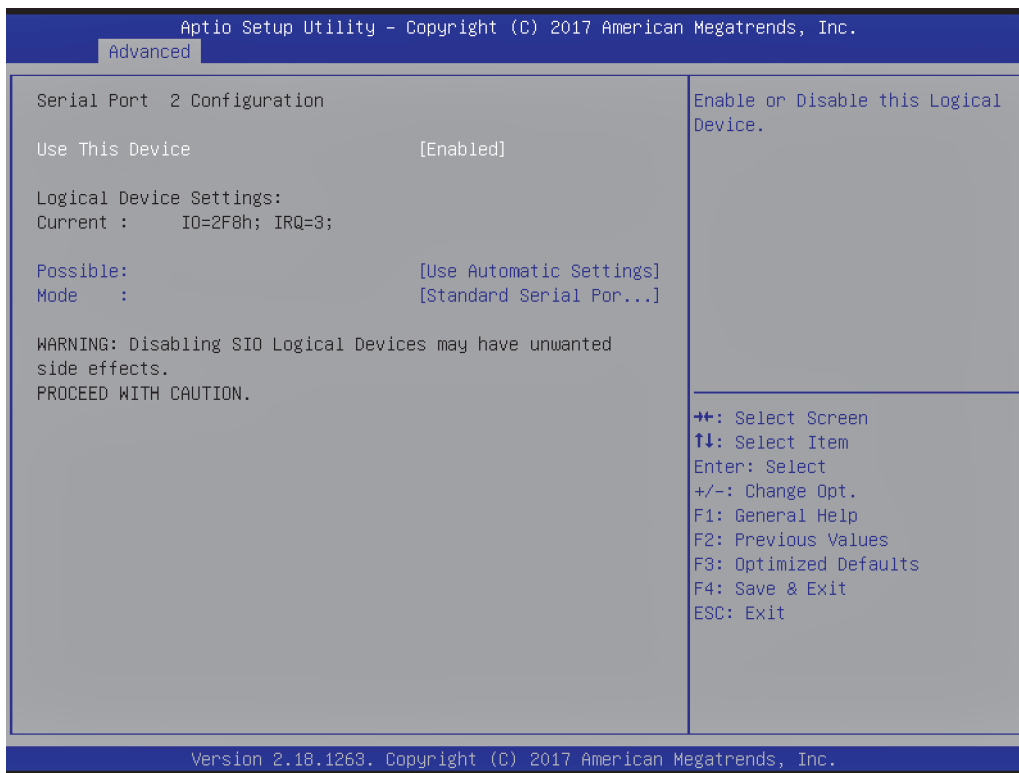

Parameter	Value	Comment
Use This Device	Enabled Disabled	Enable or Disable this Logical Device.
Possible	Use Automatic Settings IO=3F8h; IRQ=4 IO=2F8h IO=3E8h IO=2E8h IRQ=3,4,5,7,9,10,11,12	Configure Device's Resource settings. New settings will be reflected on This Setup Page after System restarts.
Mode	Standard Serial Port Mode IrDA Active pulse 1.6 μS IrDA Active pulse 3/16 bit time ASKIR Mode	Configure Standard or IrDA Mode of the Serial Port.

Parallel Port Configuration



Parameter	Value	Comment
Use This Device	Enabled Disabled	Enable or Disable this Logical Device.
Possible	Use Automatic Settings IO=378h; IRQ=5 IO=278h IO=3BCh IRQ=5,6,7,9,10,11,12	Configure Device's Resource settings. New settings will be reflected on This Setup Page after System restarts.
Mode	STD Printer Mode SPP Mode EPP-1.9 and SPP Mode EPP-1.7 and SPP Mode ECP Mode ECP and EPP 1.9 Mode ECP and EPP 1.7 Mode	Change Parallel Port mode. Some of the Modes required a DMA resource. After Mode changing, Reset the System to reflect actual device settings.

PS2 Controller (KB&MS) Configuration

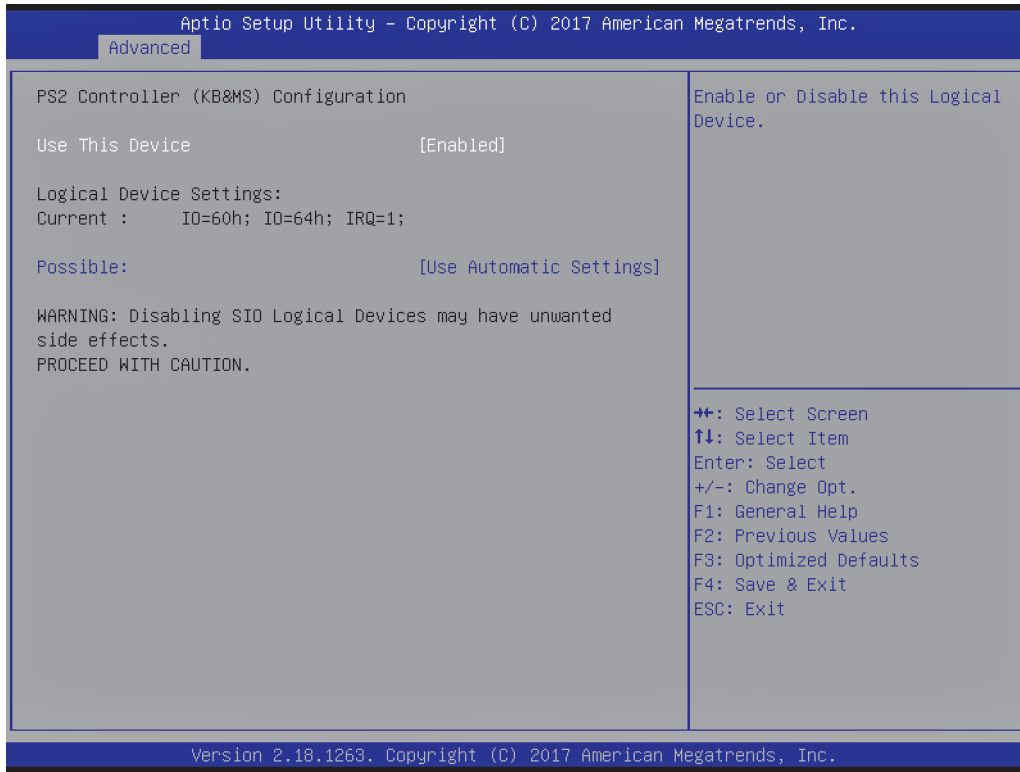

Parameter	Value	Comment
Use This Device	Enabled Disabled	Enable or Disable this Logical Device.
Possible	Use Automatic Settings IO=60h; IO=64h; IRQ=1	Configure Device's Resource settings. New settings will be reflected on this Setup Page after System restarts.

Network Stack Configuration

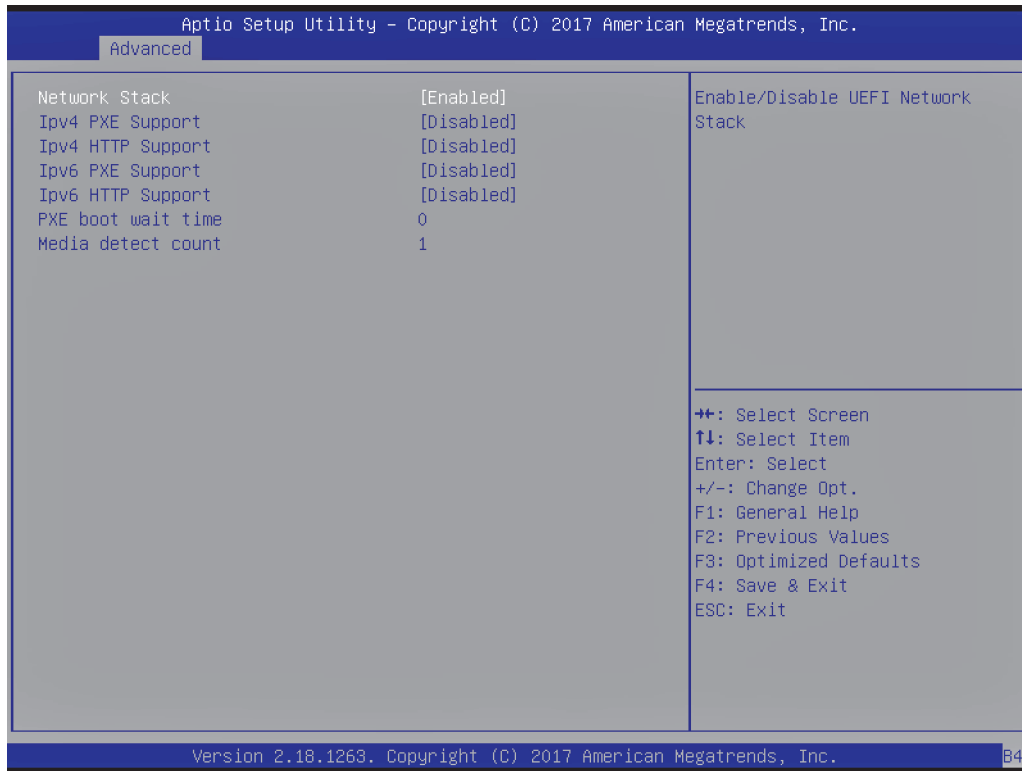

Parameter	Value	Comment
Network Stack	Enabled Disabled	Enable/Disable UEFI Network Stack.
Ipv4 PXE Support	Enabled Disabled	Enable Ipv4 PXE Boot Support. If disabled IPV4 PXE boot option will not be created.
Ipv4 HTTP Support	Enabled Disabled	Enable Ipv4 HTTP Boot Support. If disabled IPV4 HTTP boot option will not be created.
Ipv6 PXE Support	Enabled Disabled	Enable Ipv6 PXE Boot Support. If disabled IPV6 PXE boot option will not be created.
Ipv6 HTTP Support	Enabled Disabled	Enable Ipv6 HTTP Boot Support. If disabled IPV6 HTTP boot option will not be created.
PXE boot wait time	0 ... 5 (0 default)	Wait time to press ESC key to abort the PXE boot.
Media detect count	1 ... 50 (1 default)	Number of times presence of media will be checked.

Compatibility Support Module (CSM) Configuration

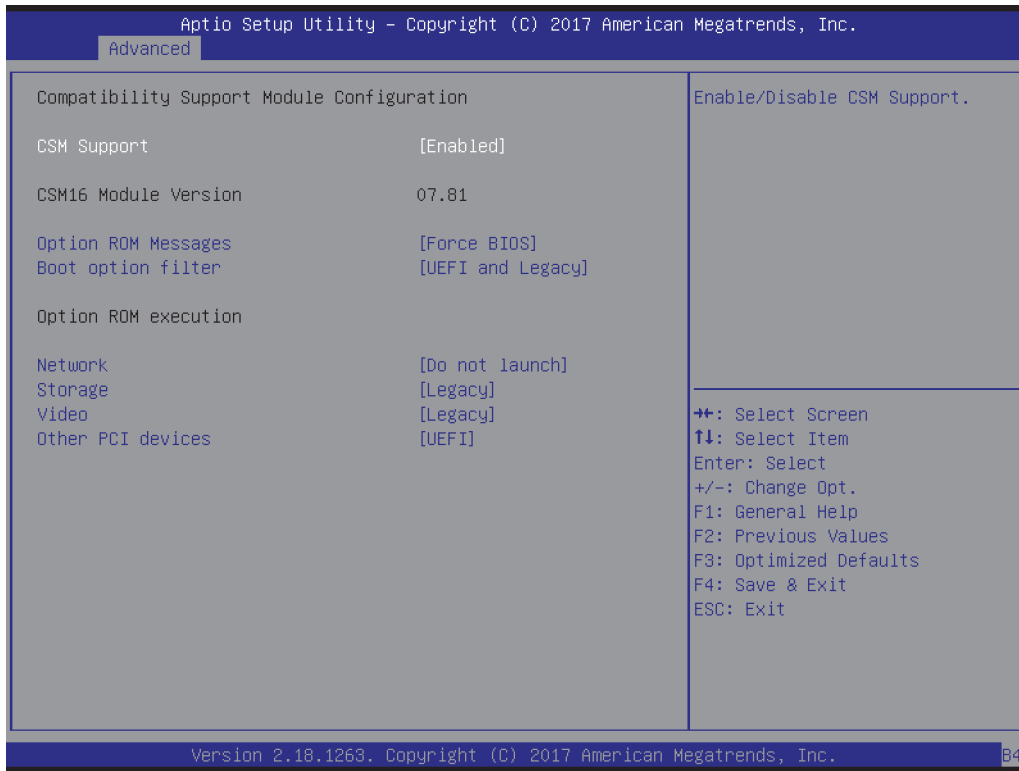

Parameter	Value	Comment
CSM Support	Enabled Disabled	Enable/Disable CSM Support.
Option ROM Messages	Force BIOS Keep Current	Force BIOS: Change display to text mode and show OpROM messages. Keep Current: Don't change display mode and suppress legacy OpROM messages.
Boot Option Filter	UEFI and Legacy Legacy only UEFI only	Configure available boot options.
Network	Do not launch UEFI Legacy	Controls the execution of UEFI and Legacy PXE OpROM.
Storage	Do not launch UEFI Legacy	Controls the execution of UEFI and Legacy Storage OpROM.
Video	Do not launch UEFI Legacy	Controls the execution of UEFI and Legacy Video OpROM.
Other PCI Devices	Do not launch UEFI Legacy	Determines OpROM execution policy for devices other than Network, Storage, or Video.

USB Configuration

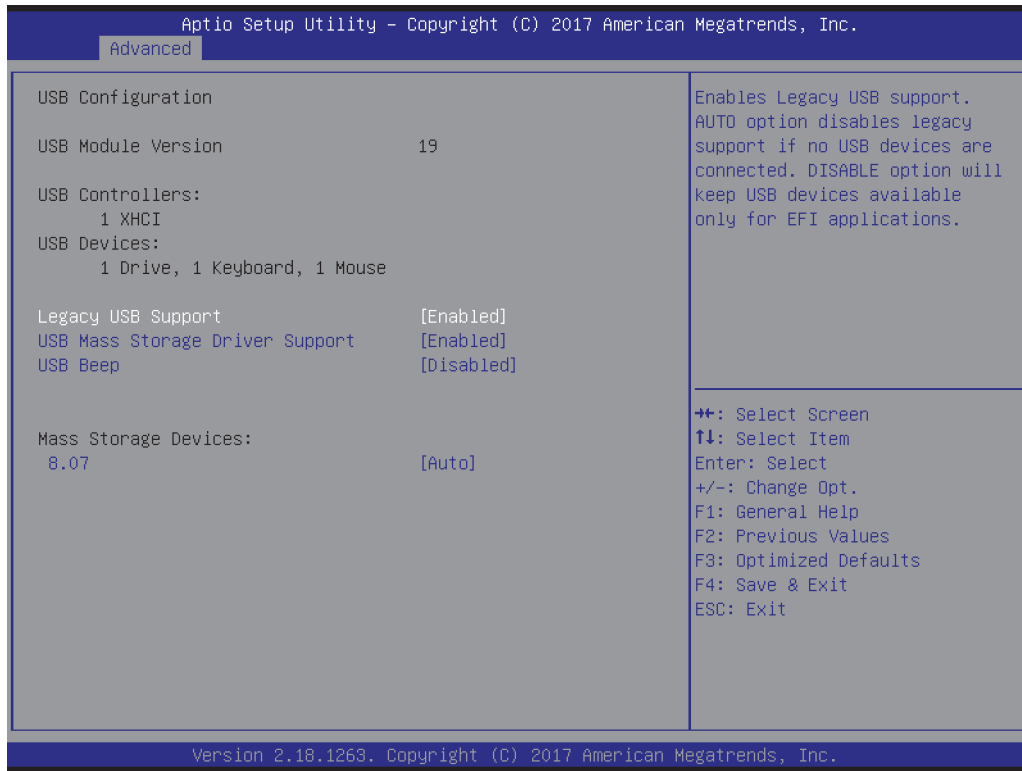

Parameter	Value	Comment
Legacy USB Support	Enabled Disabled Auto	Enables Legacy USB support. Auto: Disables legacy support if no USB devices are connected. Disabled: Keep USB devices available only for EFI applications.
USB Mass Storage Driver Support	Enabled Disabled	Enable/Disable USB Mass Storage Driver Support.
USB Beep	Enabled Disabled	Enable/Disable Beep on USB events.
Mass Storage Devices	Auto Floppy Forced FDD Hard Disk CD-ROM	Mass storage device emulation type. 'AUTO' enumerates devices according to their media format. Optical drives are emulated as 'CD-ROM', drives with no media information will be emulated according to a drive type.

Module Peripherals Configuration

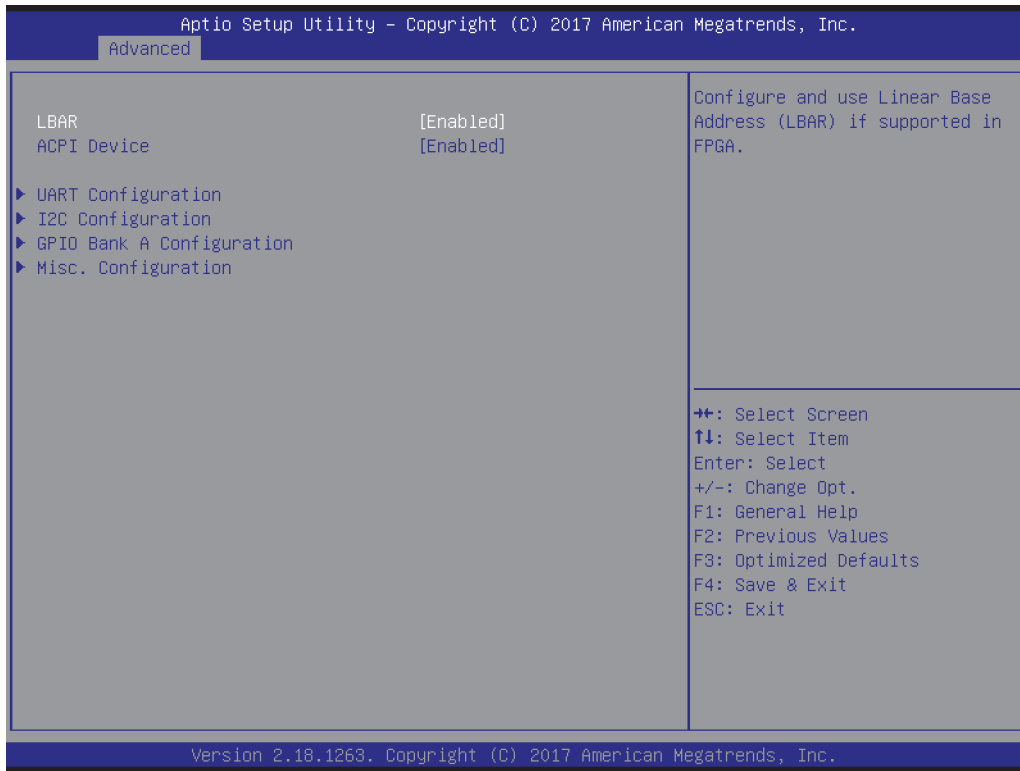

Parameter	Value	Comment
LBAR	Enabled Disabled	Configure and use Linear Base Address (LBAR) if supported in FPGA.
ACPI Devices	Enabled Disabled	Select how resources are reported to the OS via ACPI. Enabled: Separate device, may require Driver. Disabled: Motherboard Resource.
UART Configuration	Submenu	Configure integrated UARTs.
I2C Configuration	Submenu	Configure integrated I2C controllers.
GPIO Bank A Configuration	Submenu	Configure GPIO Bank A pins.
Misc. Configuration	Submenu	Miscellaneous Configuration

UART Configuration

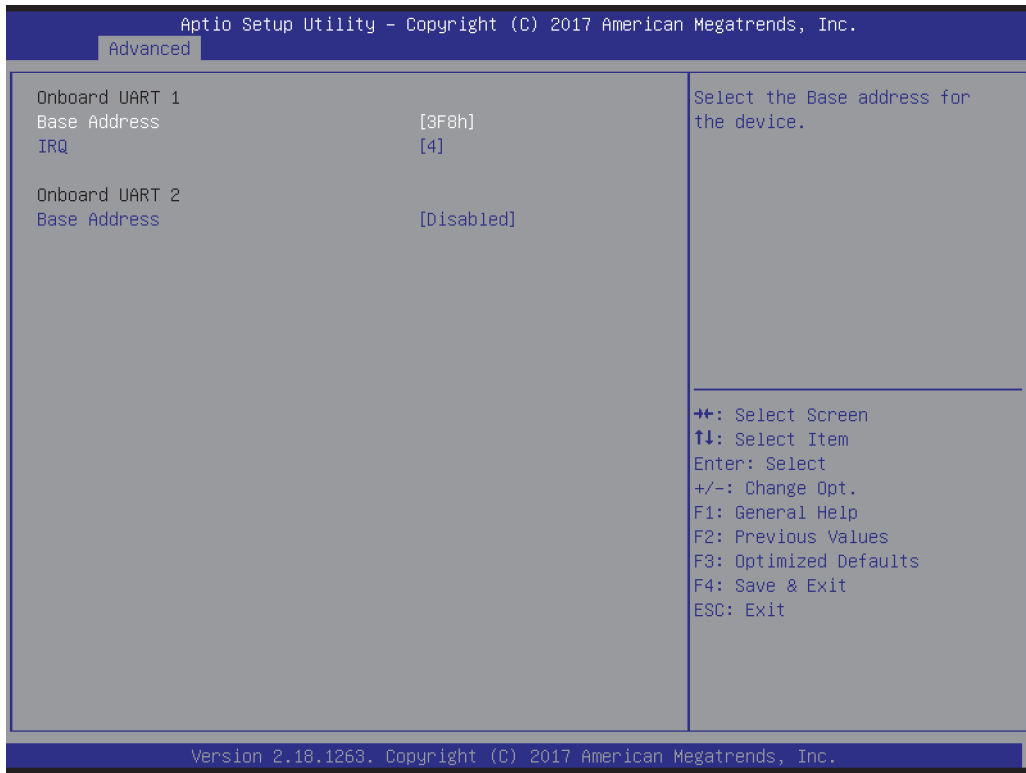

Parameter	Value	Comment
Base Address	Disabled 3F8h 2F8h 3E8h 2E8h	Select the Base address for the device.
IRQ	Disabled 3, 4, 5, 6, 7, 10, 11, 12, 14, 15	Select the IRQ for the device.

I2C Configuration

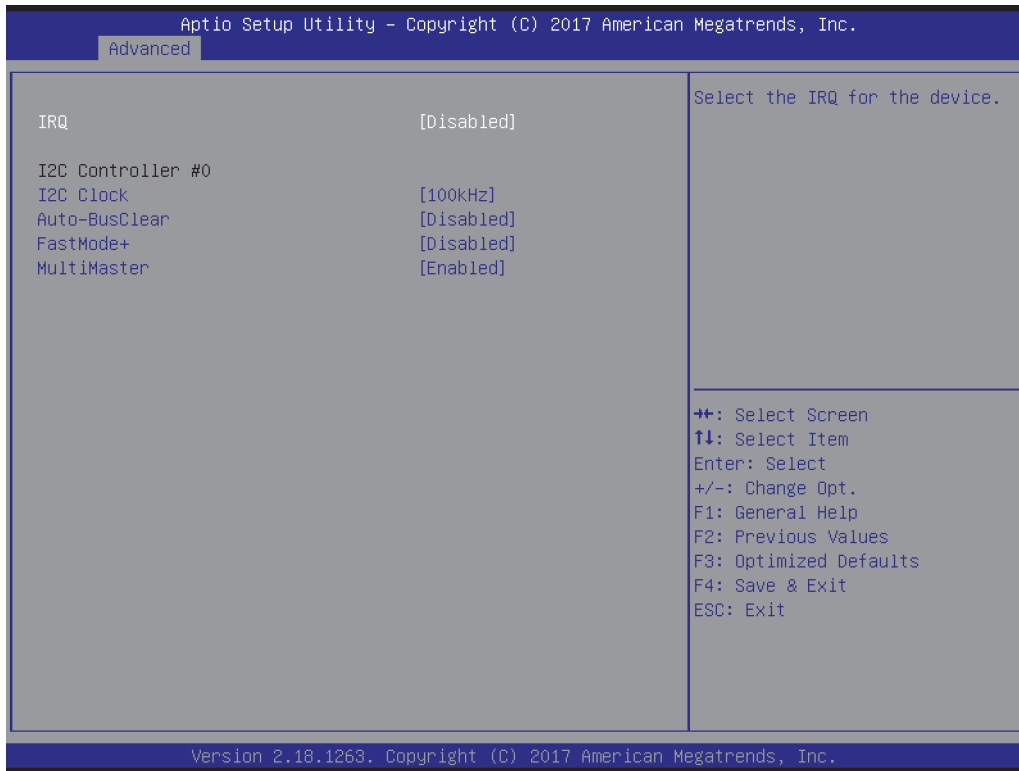

Parameter	Value	Comment
IRQ	Disabled 3, 4, 5, 6, 7, 10, 11, 12, 14, 15	Select the IRQ for the device.
I2C Clock	1kHz 10kHz 50kHz 100kHz 200kHz 400kHz 625kHz 800kHz	Select I2C Speed (OS driver may use different speed). Note: Depending on I2C controller, actual speed may be slightly below selected values.
Auto-BusClear	Disabled Automatic	If enabled, the I2C controller monitors the SDA line for conditions where the slave device blocks it and tries to recover the bus by pulsing the SCL line. Note: If enabled, the multi-master capability is no longer guaranteed!
FastMode+	Enabled Disabled	If enabled, the SCL line is switched from open drain to push-pull to allow for higher speeds. Note: If enabled, multi-master capability and Clock stretching functionality is no longer guaranteed!
MultiMaster	Enabled Disabled	If disabled, the I2C master will omit bus arbitration.

GPIO Configuration

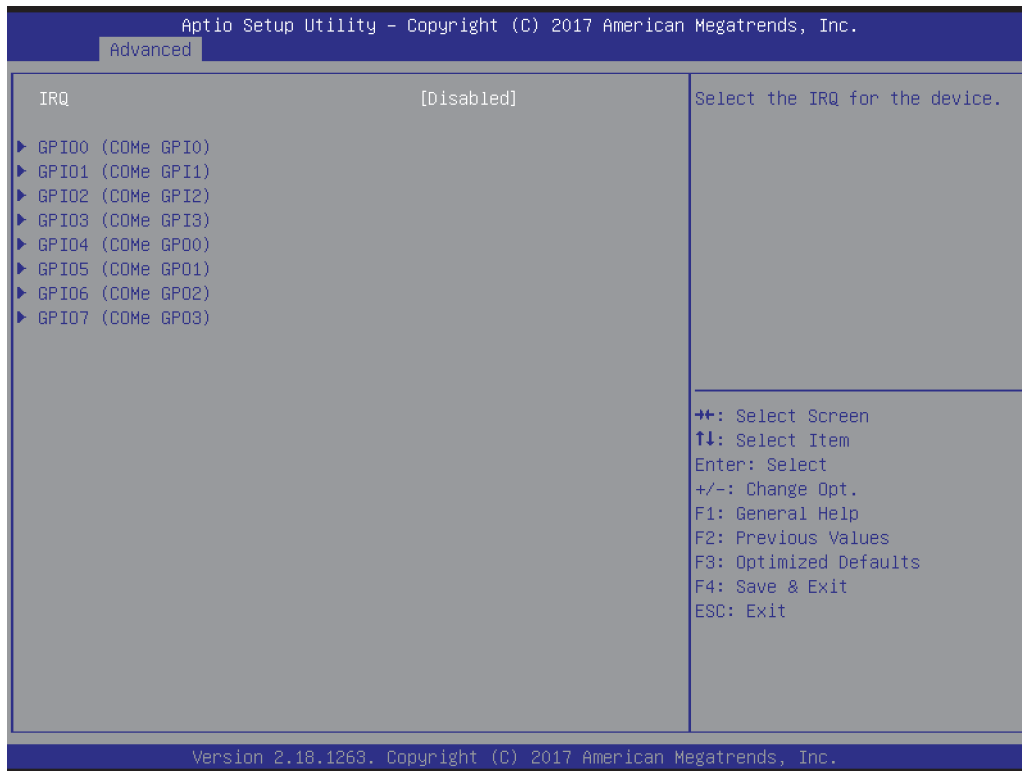

Parameter	Value	Comment
IRQ	Disabled 3, 4, 5, 6, 7, 10, 11, 12, 14, 15	Select the IRQ for the device.
GPIO0 (COMe GPIO)	Submenu	Configure GPIO Bank A pins.
GPIO1 (COMe GPI1)	Submenu	
GPIO2 (COMe GPI2)	Submenu	
GPIO3 (COMe GPI3)	Submenu	
GPIO4 (COMe GPO0)	Submenu	
GPIO5 (COMe GPO1)	Submenu	
GPIO6 (COMe GPO2)	Submenu	
GPIO7 (COMe GPO3)	Submenu	

GPI00 - GPIO2

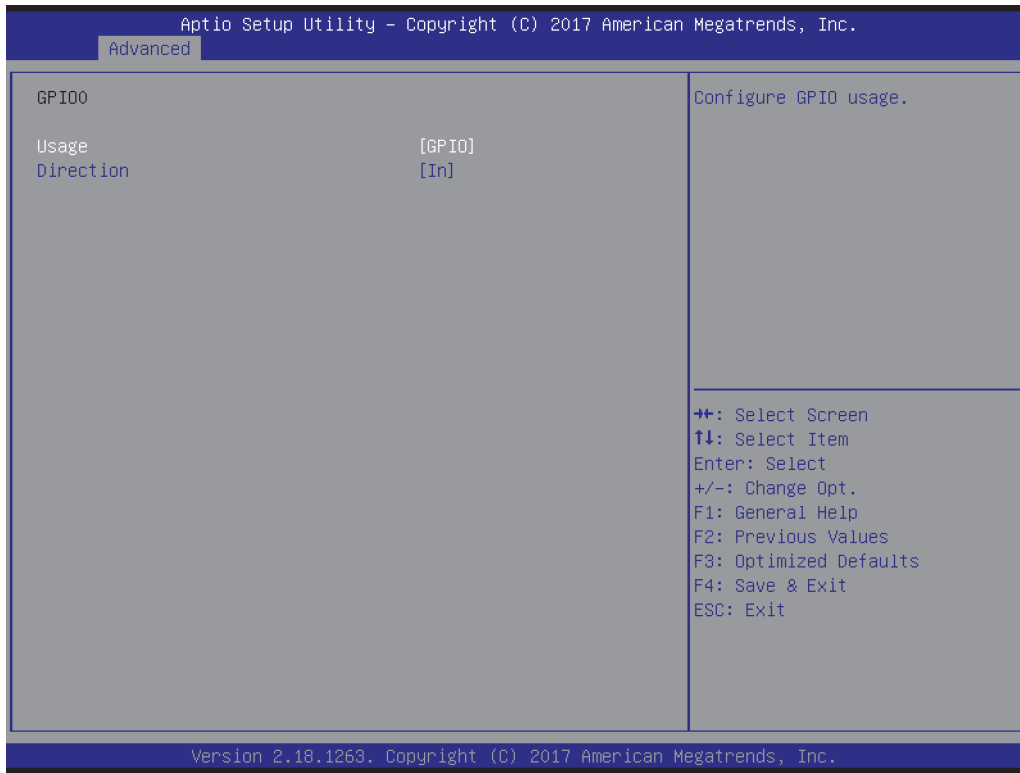

Parameter	Value	Comment
Usage	GPIO	Configure GPIO usage.
Direction	In (default for GPIO0-3) Out (default for GPIO5-7)	Configure GPIO direction.
Level	Low-Level High-Level	Configure GPIO initial level.

GPI03

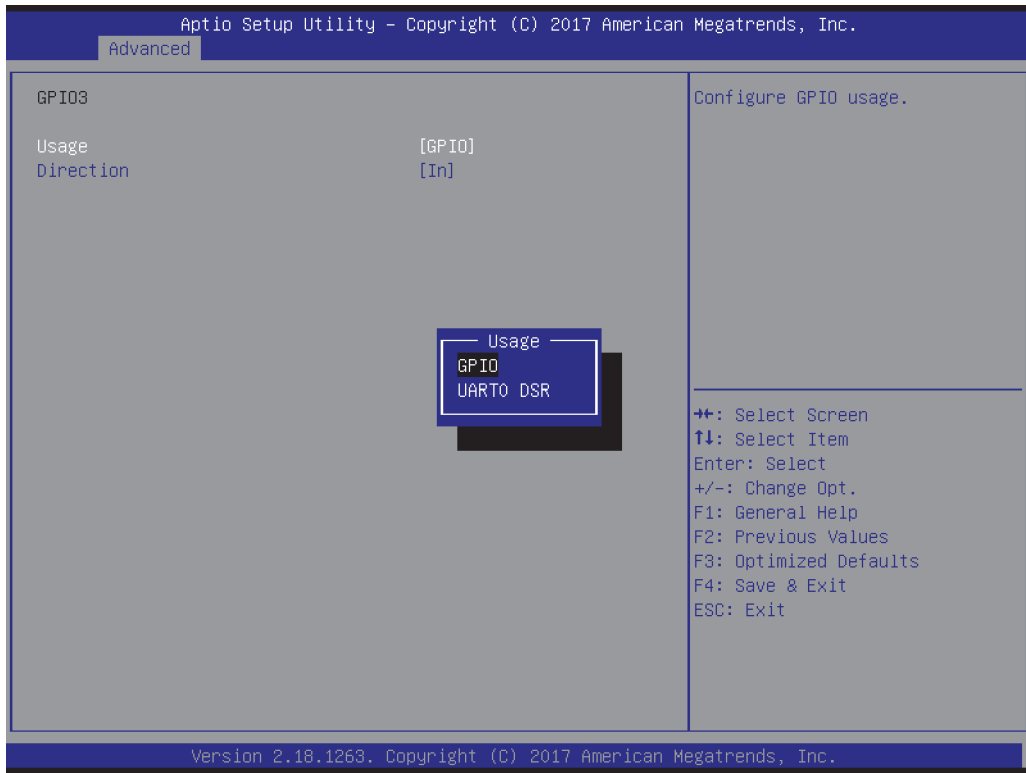

Parameter	Value	Comment
Usage	GPIO UART0 DSR	Configure GPIO usage.
Direction	In (default for GPIO0-3) Out (default for GPIO5-7)	Configure GPIO direction.
Level	Low-Level High-Level	Configure GPIO initial level.

GPI04

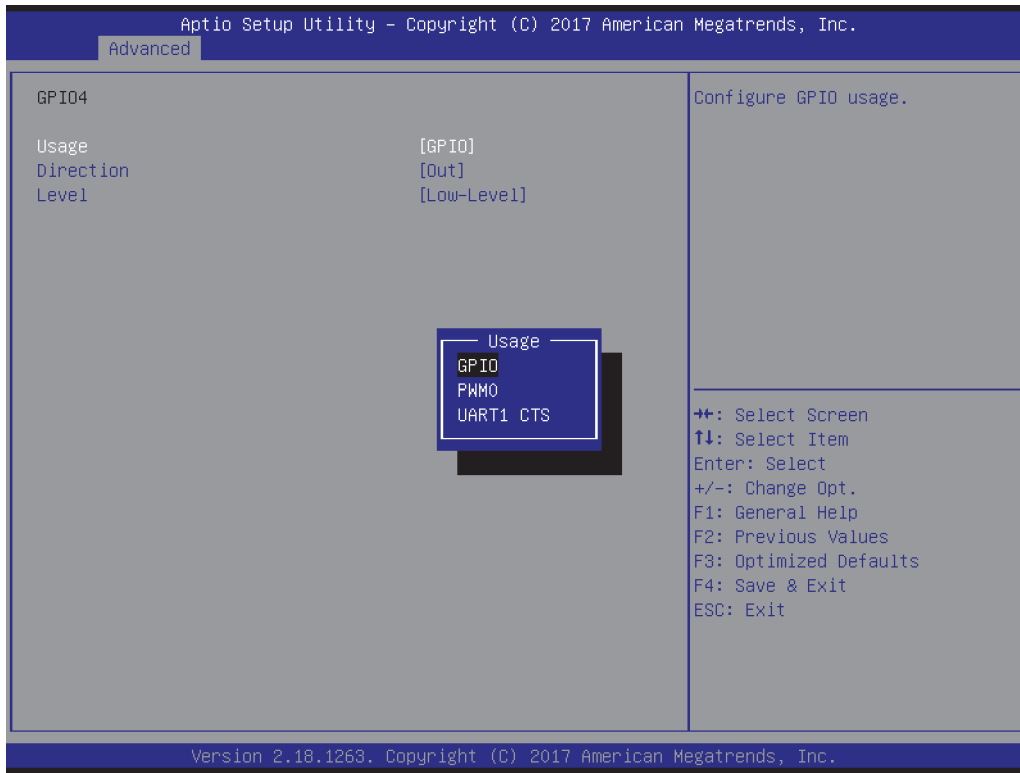

Parameter	Value	Comment
Usage	GPIO PWM0 UART1 CTS	Configure GPIO usage.
Direction	In (default for GPI00-3) Out (default for GPI05-7)	Configure GPIO direction.
Level	Low-Level High-Level	Configure GPIO initial level.

GPI06

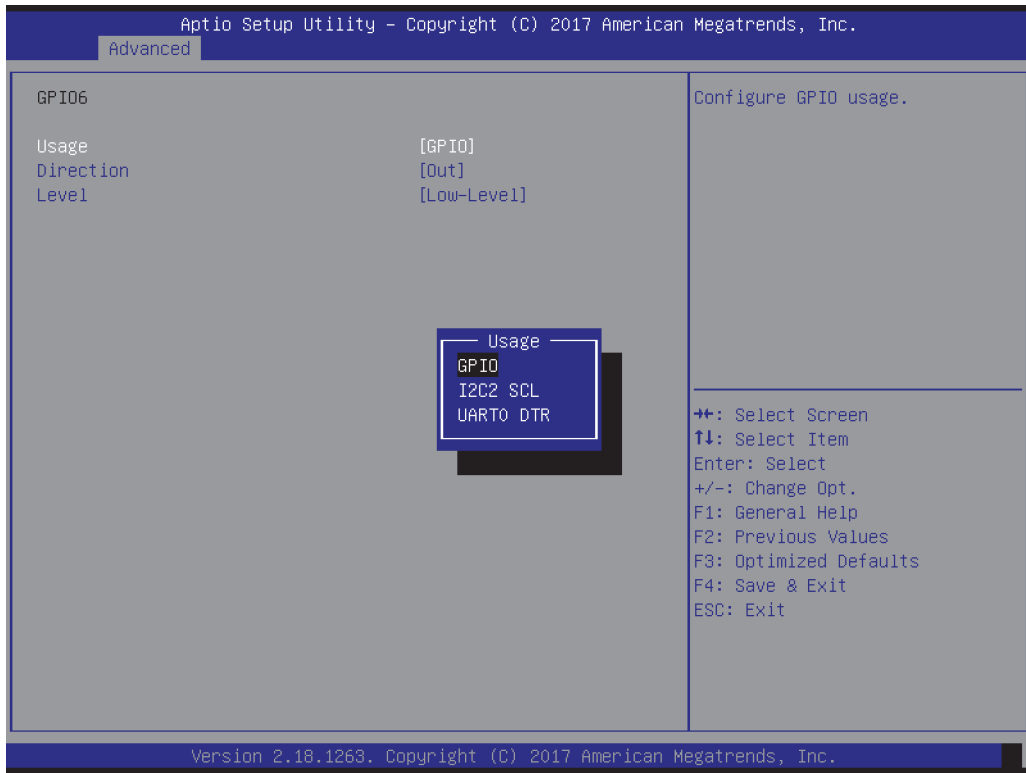

Parameter	Value	Comment
Usage	GPIO I2C2 UART0 DTR	Configure GPIO usage.
Direction	In (default for GPIO0-3) Out (default for GPIO5-7)	Configure GPIO direction.
Level	Low-Level High-Level	Configure GPIO initial level.

GPI07

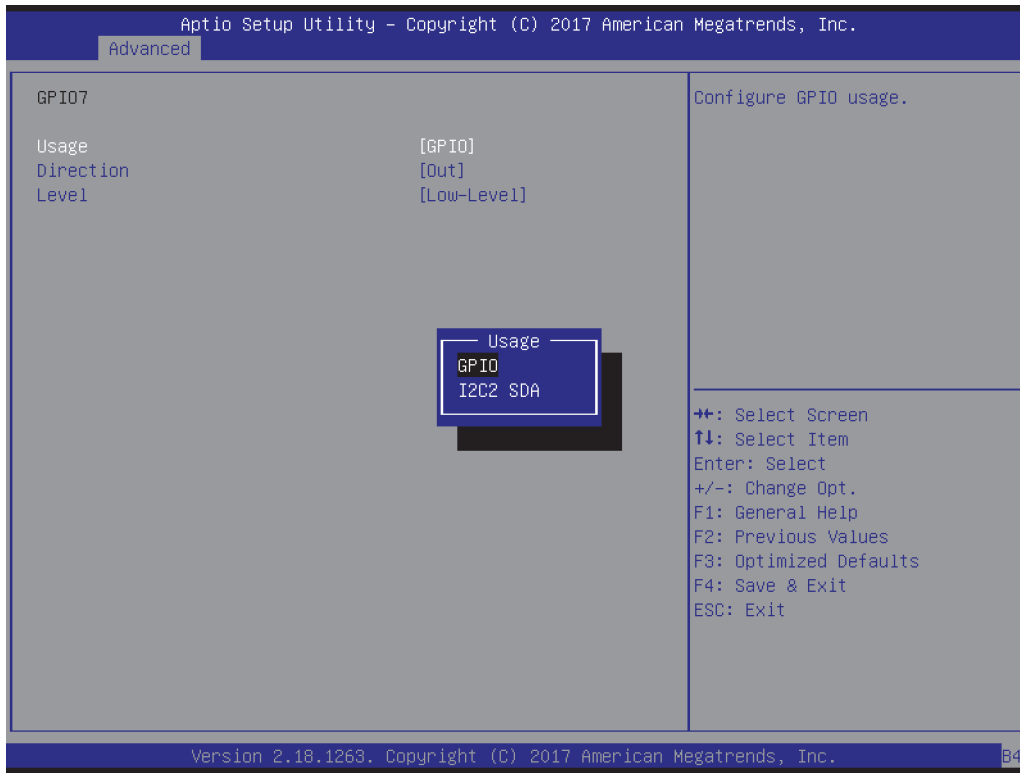

Parameter	Value	Comment
Usage	GPIO I2C2 SDA	Configure GPIO usage.
Direction	In (default for GPIO0-3) Out (default for GPIO5-7)	Configure GPIO direction.
Level	Low-Level High-Level	Configure GPIO initial level.

Misc. Configuration

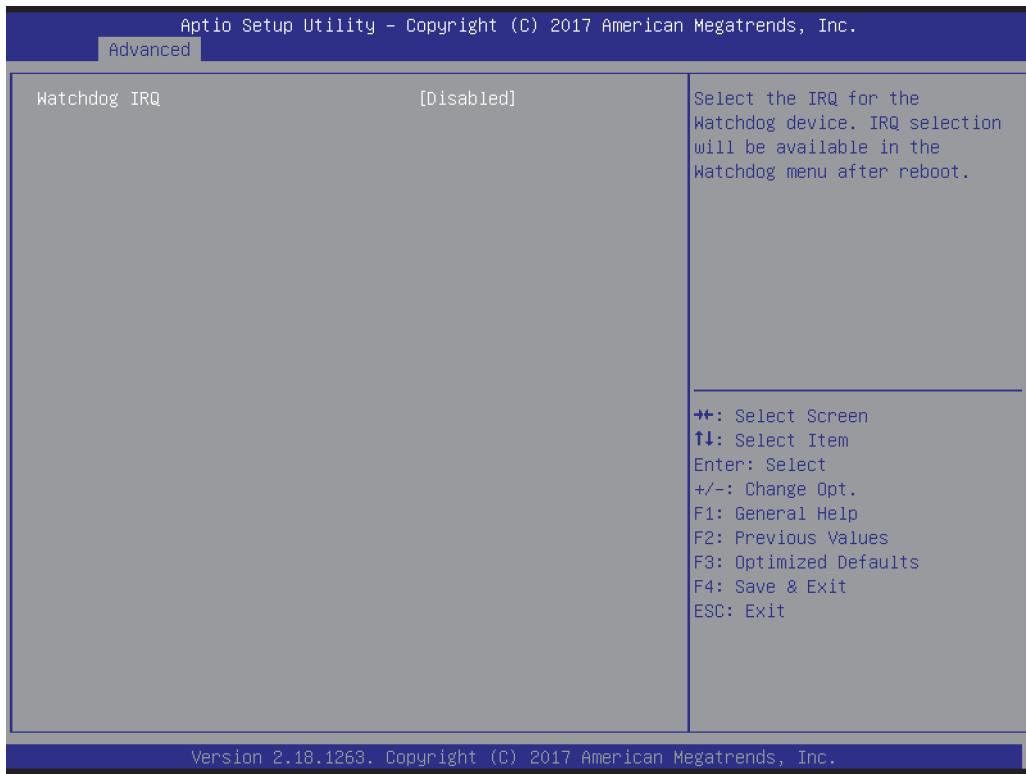

Parameter	Value	Comment
Watchdog IRQ	Disabled 3, 4, 5, 6, 7, 10, 11, 12, 14, 15	Select the IRQ for the Watchdog device. IRQ selection will be available in the Watchdog menu after reboot.

Module H/W Monitor

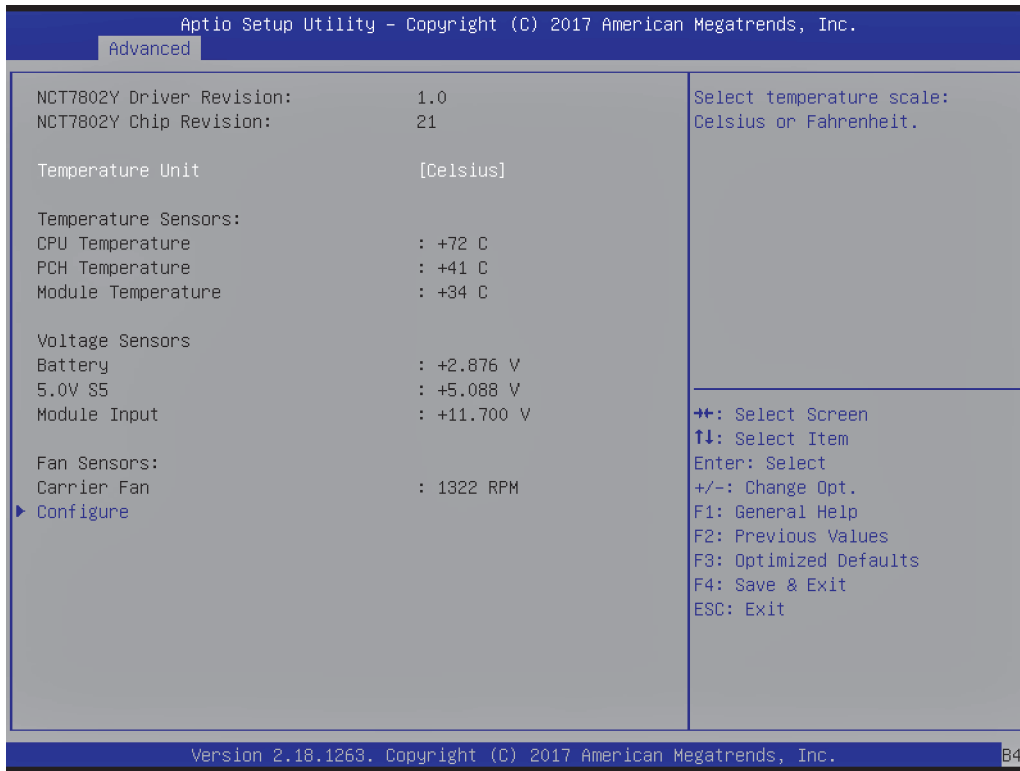

Parameter	Value	Comment
Temperature Unit	Celsius Fahrenheit	Select temperature scale: Celsius or Fahrenheit.
Configure Fan Sensors	Submenu	Configure Fan parameters.

Fan Configuration

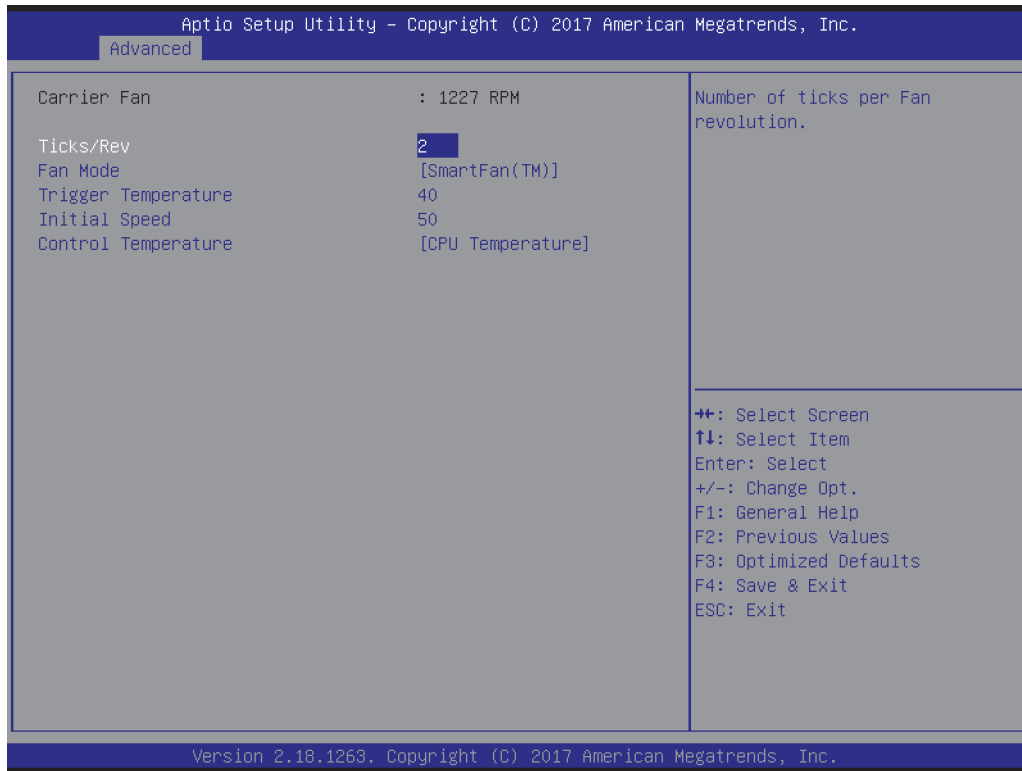

Parameter	Value	Comment
Ticks/Rev	1 ... 16 (2 default)	Number of ticks per Fan revolution.
Fan Mode	Off Manual SmartFan(TM)	Select Fan mode of operation.
Fan Speed	10 ... 100 (40 default)	Select fixed Fan Speed in %.
Trigger Temperature	Celsius: 20 ... 80 (40 default) Fahrenheit: 68 ... 176 (104 default)	Select the temperature at which the Fan starts spinning.
Initial Speed	10 ... 80 (50 default)	Initial Fan Speed in %.
Control Temperature	CPU Temperature PCH Temperature Module Temperature	Temperature to use.

Module Watchdog Configuration

Standard Mode



Parameter	Value	Comment
Watchdog	Disabled Standard Mode Window Mode	Enable/Disable Watchdog and select Mode.
Auto Reload	Enabled Disabled	Enable Auto Reload. If enabled, Timeout registers will be reloaded automatically after expiration.
Lock	Enabled Disabled	If enabled, the Watchdog registers will be locked and become read only after initialization.
Stage	Submenu	Configure Watchdog Stage.

Stage Configuration

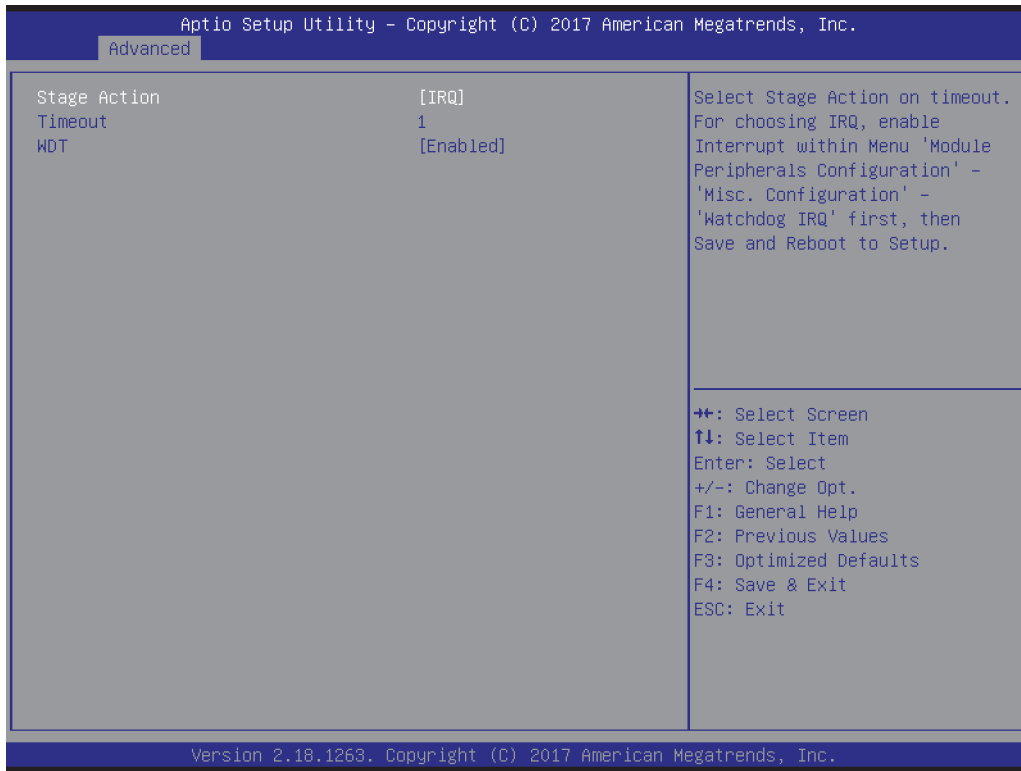

Parameter	Value	Comment
Stage Action	Disabled Delay None Reset NMI IRQ	Select Stage Action on timeout. For choosing IRQ, enable Interrupt within Menu 'Module Peripherals Configuration' – 'Misc. Configuration' – Watchdog IRQ' first, then Save and Reboot to Setup.
Timeout	1 ... 65535 (1 default)	Select the timeout value for the stage.
WDT#	Enabled Disabled	Assert WDT# signal to Baseboard.

Window Mode

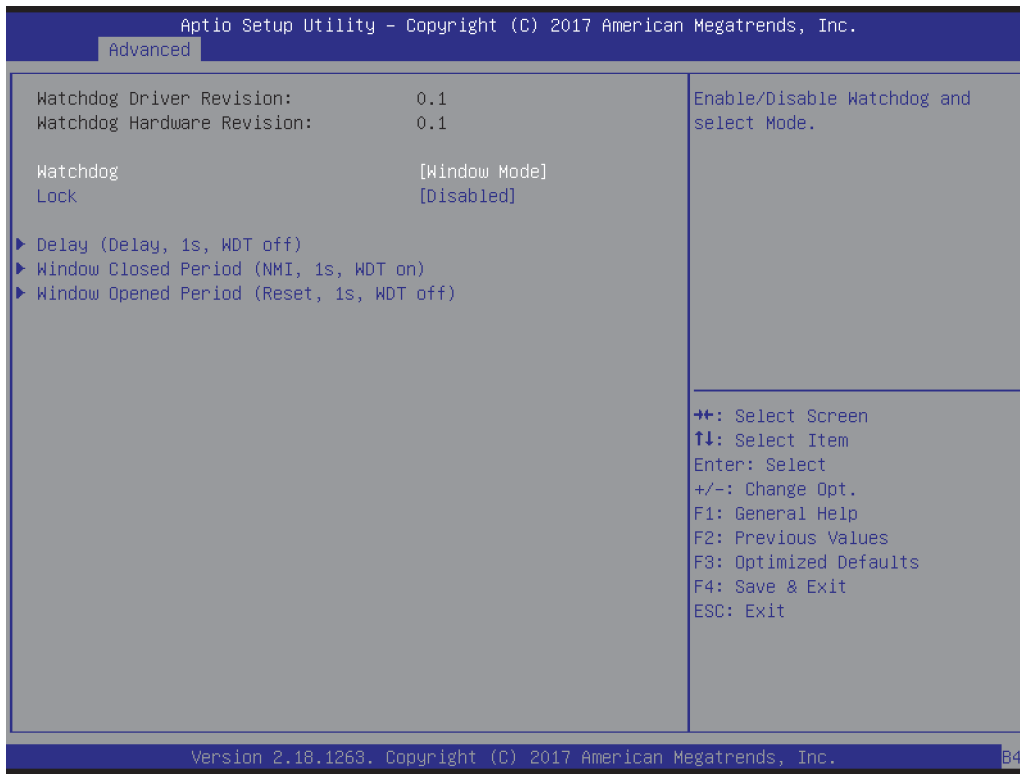

Parameter	Value	Comment
Watchdog	Disabled Standard Mode Window Mode	Enable/Disable Watchdog and select Mode.
Lock	Enabled Disabled	If enabled, the Watchdog registers will be locked and become read only after initialization.
Delay	Submenu	Enable/Disable Watchdog and select Mode.
Window Closed Period	Submenu	Trigger events during this period will be treated as error and cause the time-out event selected in the Window Open Stage.
Window Opened Period	Submenu	Trigger events during this period will reload the watchdog timer and transition the internal state machine to the Window Closed Stage.

Module Display Configuration



Parameter	Value	Comment
Primary IGFX Boot Display	Auto LFP EFP1 EFP2 EFP3 CRT	Select the Video Device which will be activated during POST. This has no effect if external graphics present. Secondary boot display selection will appear based on your selection. VGA modes will be supported only on primary display.
Secondary IGFX Boot Display	Disabled LFP EFP1 EFP2 EFP3 CRT	Select Secondary Display Device.
LFP Panel Type	Auto LVDS EEPROM Carrier EEPROM Module EEPROM 640x480 800x600 ...	Select LFP timings used by Internal Graphics Device. LVDS, Carrier and Module EEPROM timings are available if appropriate data is found.
LFP Fallback Type	Disabled 640x480 800x600 ...	Enable LFP with selected timings if auto detection fails.
Panel Color Depth	18 Bit 24 Bit VESA 24 Bit oLDI	Panel Color Depth for EDID 1.3 detection.
Panel Channel Count	Single Channel Dual Channel	Panel Channel Count for EDID detection.
Backlight Type	None PWM PWM Inverted	Select Backlight Inverter Type and Polarity.
Backlight Value	0 ... 100 (50 default)	Set Backlight Value in Percentage.
PWM Frequency	200 ... 40000 Hz (200 Hz default)	Set PWM Frequency in Hz.

Parameter	Value	Comment
Backlight On	Enabled At the End of Post	Configure if LVDS Backlight should be set when panel is powered, or inhibit until End Of Post.
Backlight OS Controlled	Enabled Disabled	Configure if PWM values can be overridden by OS Power Options.
LVDS Spread Spectrum	Disabled 0.5 % 1.0 % 1.5 % 2.0 % 2.5 %	Set LVDS Center Spreading.
EFP Type	HDMI/DVI DP w. HDMI/DVI Comp. DP only	Select the type of the EFP.

Chipset



Parameter	Value	Comment
System Agent (SA) Configuration	Submenu	System Agent (SA) Parameters (Graphics, Graphics Audio, DMI, PEG, Memory)
PCH-IO Configuration	Submenu	Platform Controller Hub Parameters

System Agent Configuration

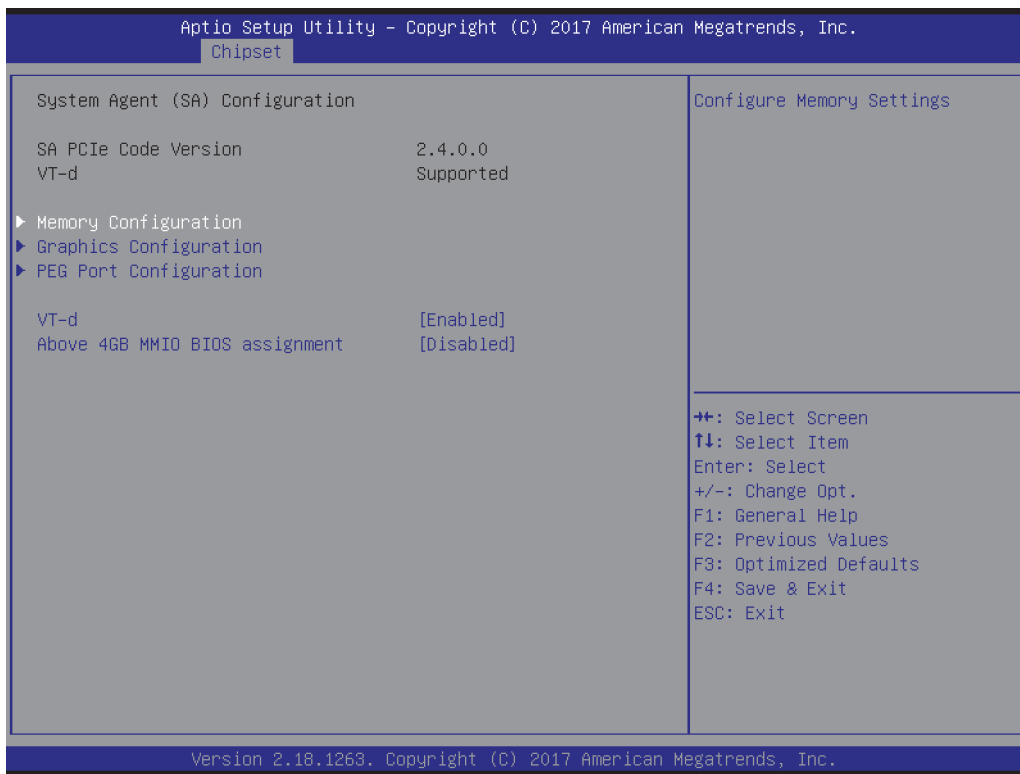

Parameter	Value	Comment
Memory Configuration	Submenu	Configure Memory Settings.
Graphics Configuration	Submenu	Configure Graphics Settings.
PEG Port Configuration	Submenu	Configure System Agent PCI Express Settings.
VT-d	Enabled Disabled	Enable/Disable VT-d function on System Agent. (Virtualization on Technology for Directed I/O)
Above 4GB MMIO BIOS assignment	Enabled Disabled	Enable/Disable above 4GB MemoryMappedIO BIOS assignment. This is disabled automatically when Aperture Size is set to 2048MB.

Memory Configuration

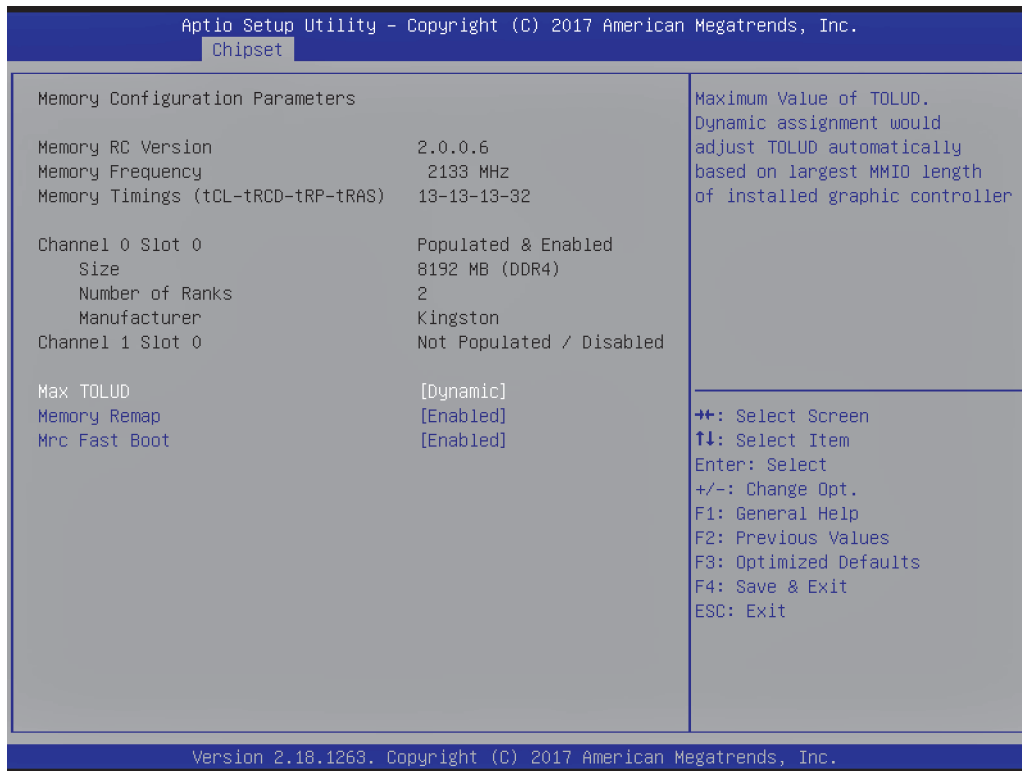

Parameter	Value	Comment
Max TOLUD	Dynamic 1 GB 1.25 GB 1.5 GB 1.75 GB 2 GB 2.25 GB 2.5 GB 2.75 GB 3 GB 3.25 GB 3.5 GB	Maximum Value of TOLUD. Dynamic assignment would adjust TOLUD automatically based on largest MMIO length of installed graphic controller.
Memory Remap	Enabled Disabled	Enable/Disable memory remap above 4GB.
MRC Fast Boot	Enabled Disabled	Enable/Disable MRC fast boot. Skips memory training if memory configuration not changed.

Graphics Configuration

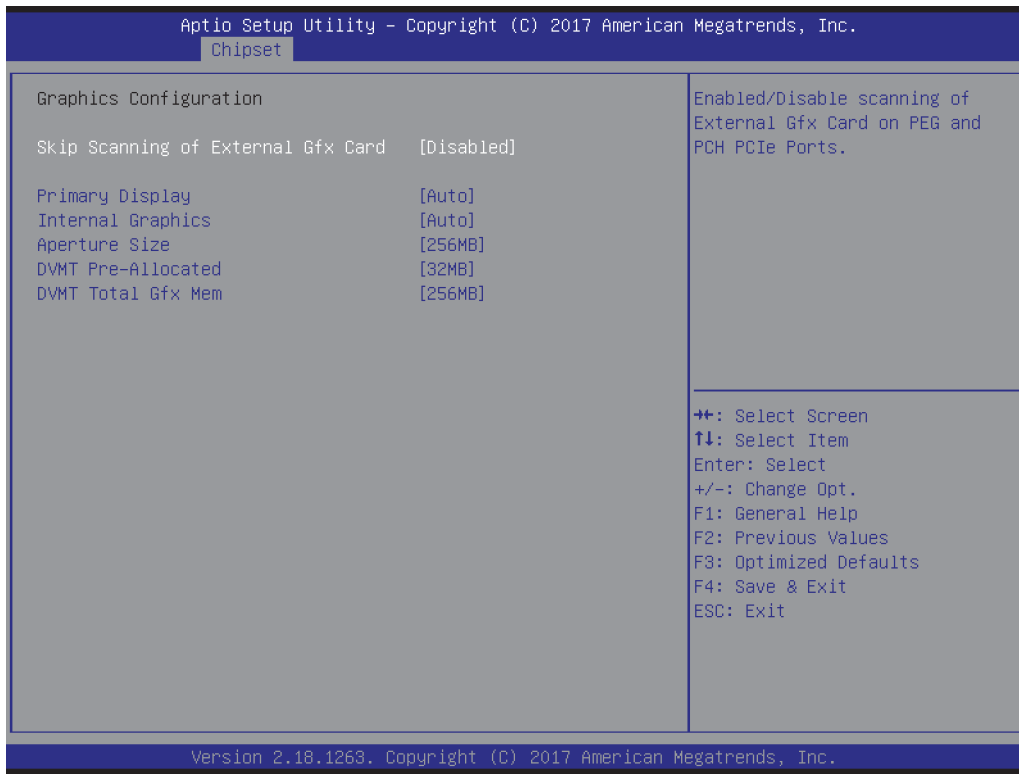

Parameter	Value	Comment
Skip Scanning of External Gfx Card	Enabled Disabled	Enabled/Disable scanning of External Gfx Card on PEG and PCH PCIe Ports.
Primary Display	Auto IGFX PEG PCIe	Select which of IGFX/PEG/PCIe Graphics Device should be Primary Display.
Internal Graphics	Auto Disabled Enabled	Keep IGFX enabled based on the setup options.
Aperture Size	128MB ... 2048MB (256MB default)	Select the Aperture Size. Note: Above 4GB MMIO BIOS assignment is automatically enabled when selecting 2048MB aperture. To use this feature, please disable CSM Support.
DVMT Pre-Allocated	0MB ... 64MB (32MB default)	Select DVMT (Dynamic Video Memory Technology) 5.0 Pre-Allocated (Fixed) Graphics Memory size used by the Internal Graphics Device.
DVMT Total Gfx Mem	128MB 256MB MAX	Select DVMT5.0 Total Graphic Memory size used by the Internal Graphics Device.

PEG Port Configuration

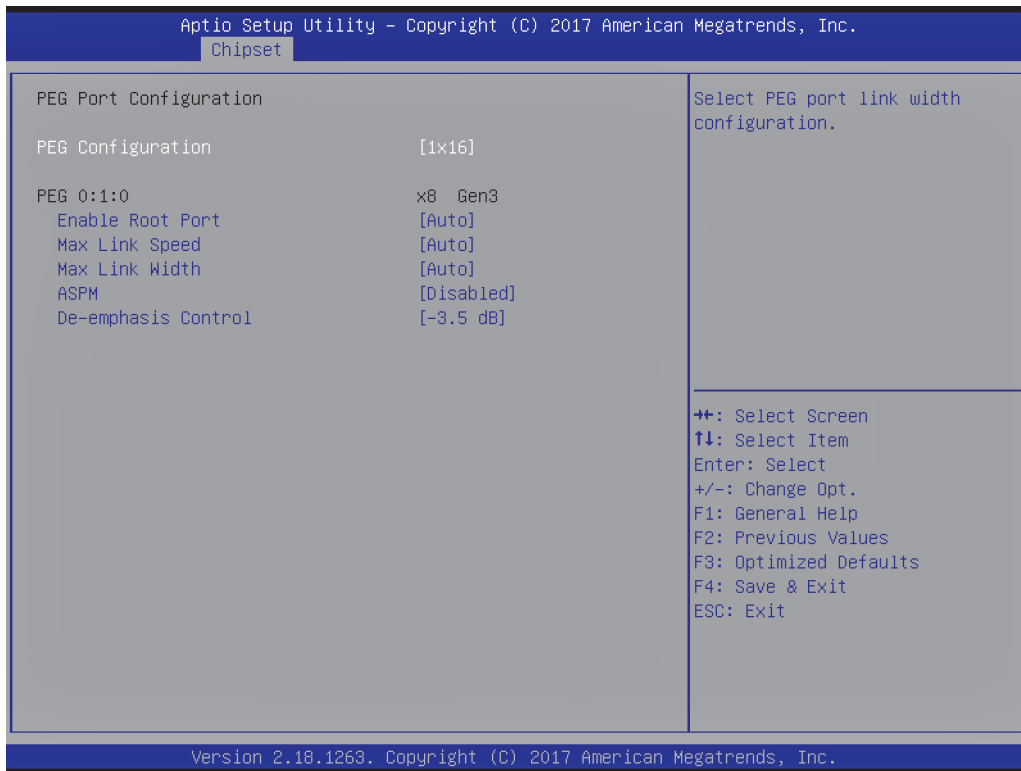

Parameter	Value	Comment
PEG Configuration	1x16 2x8 1x8 + 2x4	Select PEG port link width configuration.
Enable Root Port	Auto Disabled Enabled	Enable or Disable the Root Port.
Max Link Speed	Auto Gen1 Gen2 Gen3	Configure PEG Max Speed.
Max Link Width	Auto Force X1 Force X2 Force X4 Force X8	Force PEG link to retrain to X1/2/4/8.
ASPM	Disabled Auto ASPM L0s ASPM L1 ASPM L0sL1	Control ASPM support for the PEG Device. This has no effect if PEG is not the currently active device.
ASPM L0s	Root Port Only Endpoint Port Only Both Root and Endpoint Ports	Enable PCIe ASPM L0s.
De-emphasis Control	-6 dB -3.5 dB	Configure the De-emphasis control on PEG.

PCH-IO Configuration

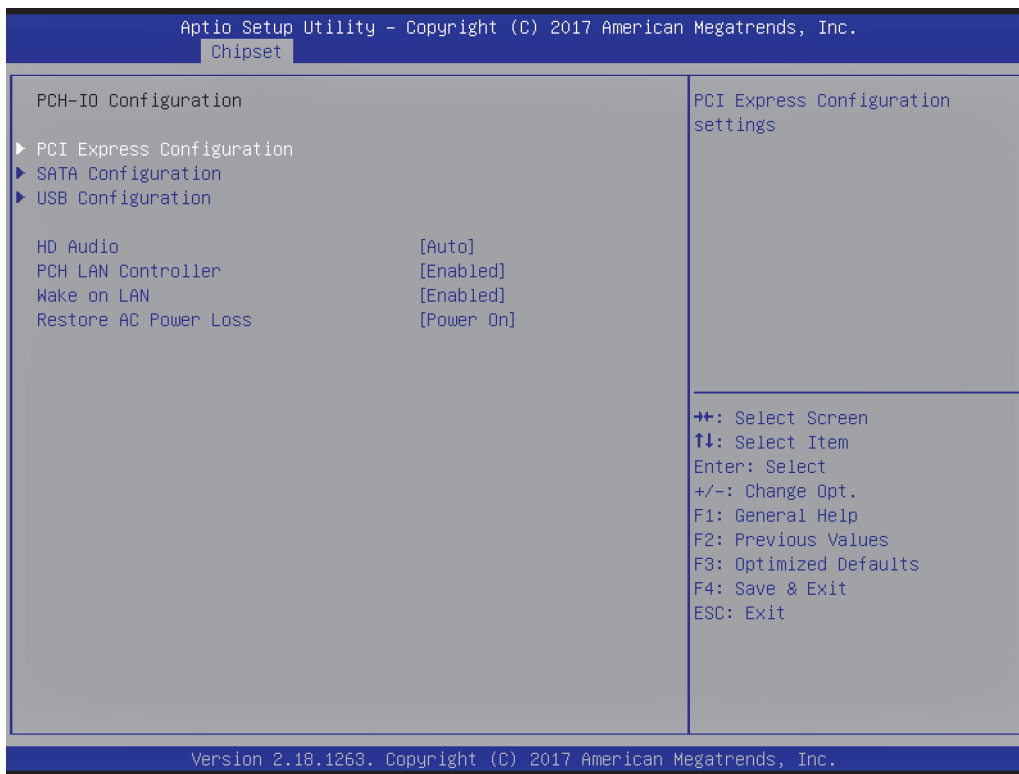

Parameter	Value	Comment
PCI Express Configuration	Submenu	PCI Express Configuration settings
SATA Configuration	Submenu	SATA Device Options settings
USB Configuration	Submenu	USB Configuration settings
HD Audio	Enabled Disabled Auto	Control Detection of the HD-Audio device. Disabled = HDA will be unconditionally disabled. Enabled = HDA will be unconditionally Enabled. Auto = HDA will be enabled if present, disabled otherwise.
PCH LAN Controller	Enabled Disabled	Enable/Disable onboard NIC.
Wake on LAN	Enabled Disabled	Enable/Disable integrated LAN to wake the system.
Restore AC Power Loss	Power Off Power On Last State	Select AC power state when power is re-applied after a power failure. Power Off and Last State need a RTC battery in the system.

PCI Express Configuration

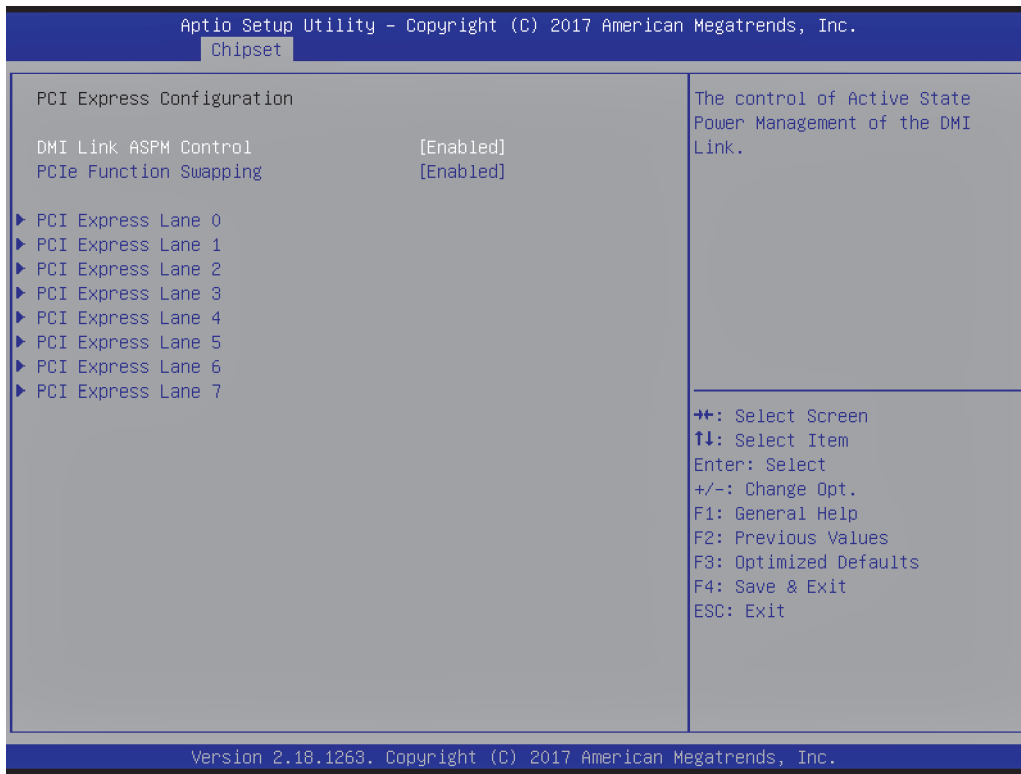

Parameter	Value	Comment
DMI Link ASPM Control	Enabled Disabled	The control of Active State Power Management of the DMI Link.
PCIe Function Swapping	Enabled Disabled	Enable/Disable PCI Express Root Port Function Swapping. When disabled and any function other than 0th is enabled, 0th will become visible.
PCI Express Lane	Submenu	PCI Express Root Port Settings.

PCI Express Lane

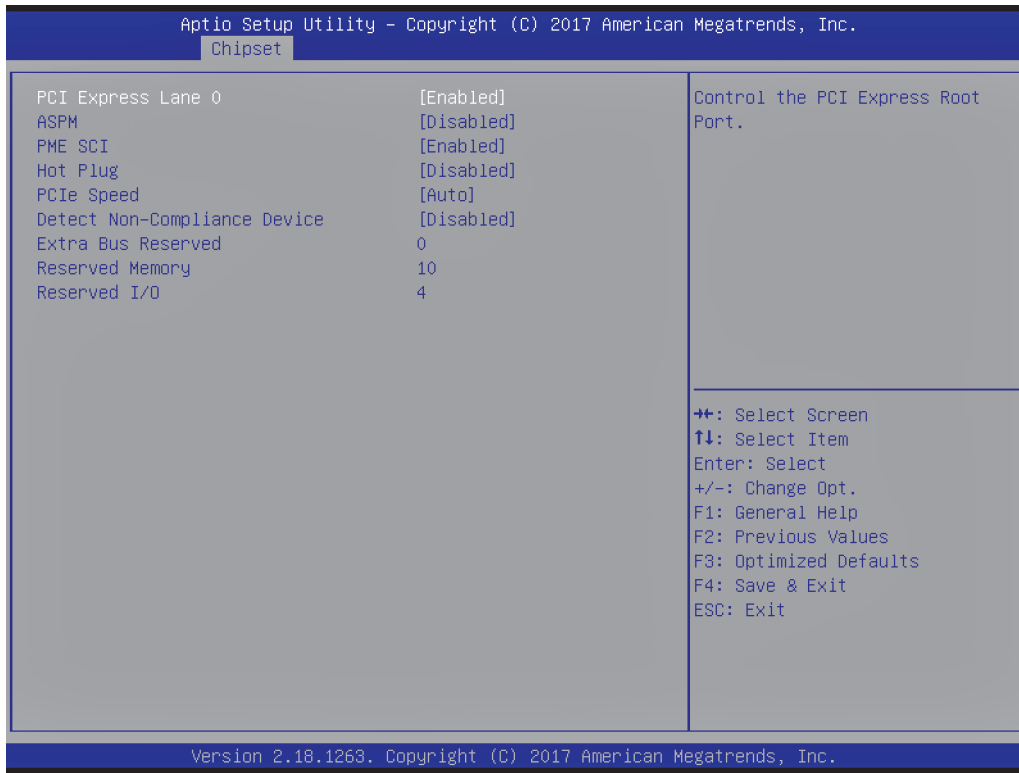

Parameter	Value	Comment
PCI Express Lane	Enabled Disabled	Control the PCI Express Root Port.
ASPM	Disabled L0s L1 L0sL1 Auto	Set the ASPM Level: Force all links to appropriate ASPM state, or Auto negotiate ASPM configuration or Disable ASPM.
PME SCI	Enabled Disabled	Enable/Disable PCI Express Power management System Control Interrupt.
Hot Plug	Enabled Disabled	Enable/Disable PCI Express Hot Plug.
PCIe Speed	Auto Gen1 Gen2	Select PCI Express Port speed.
Detect Non-Compliance Device	Enabled Disabled	Detect Non-Compliance PCI Express Devices.
Extra Bus Reserved	0 ... 7 (0 default)	Reserve extra bus (0 ... 7) for bridges behind this Root Bridge.
Reserved Memory	1 ... 20 (10 default)	Reserved memory (1 ... 20MB) for this Root Bridge.
Reserved I/O	4 ... 20 (4 default)	Reserved I/O (4kB/8kB/12kB/16kB/20kB) Range for this Root Bridge.

SATA Configuration

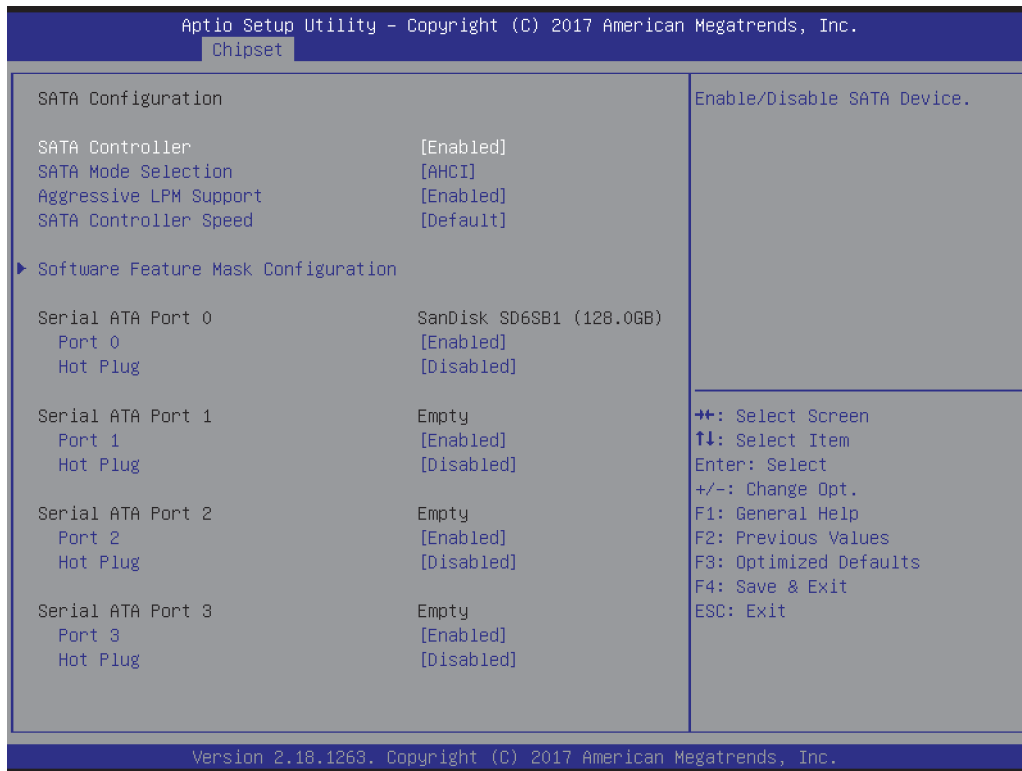

Parameter	Value	Comment
SATA Controller	Enabled Disabled	Enable/Disable SATA Device.
SATA Mode Selection	AHCI Intel RST	Determines how SATA controller operate.
Aggressive LPM Support	Enabled Disabled	Enable PCH to aggressively enter link power state.
SATA Controller Speed	Default Gen1 Gen2 Gen3	Default configures controller speed to max supported speed of connected devices. Other values limit speed to according value. Gen1: 1GB/s, Gen2: 3Gb/s, Gen3: 6Hb/s
Software Feature Mask Configuration	Submenu	Configure RAID and Smart Response Technology features.
SATA Port	Enabled Disabled	Enable/Disable SATA Port.
Hot Plug	Enabled Disabled	Designates this port as Hot Pluggable.

Software Feature Mask Configuration

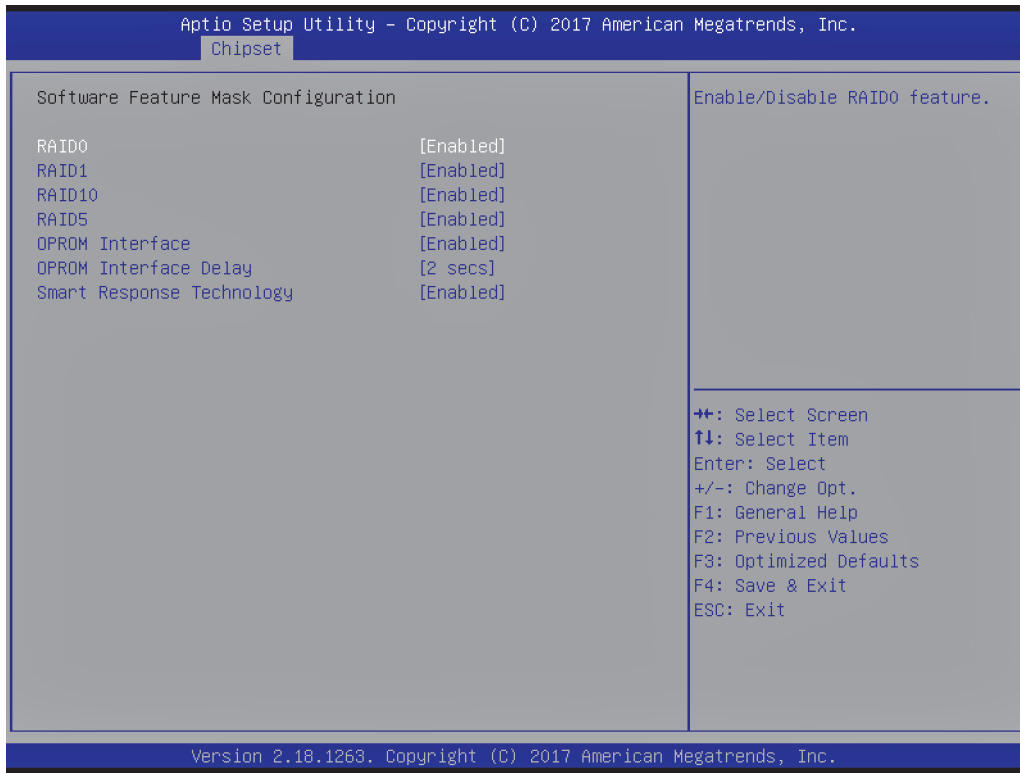

Parameter	Value	Comment
RAID0	Enabled Disabled	Enable/Disable RAID0 feature.
RAID1	Enabled Disabled	Enable/Disable RAID1 feature.
RAID10	Enabled Disabled	Enable/Disable RAID10 feature.
RAID5	Enabled Disabled	Enable/Disable RAID5 feature.
OPROM Interface	Enabled Disabled	If enabled, the OPROM User Interface is shown. Otherwise, no OPROM banner or information will be displayed if all disks and RAID volumes are normal.
OPROM Interface Delay	2 Seconds 4 Seconds 6 Seconds 8 Seconds	Select the delay time of the OPROM Splash Screen in a normal status.
Smart Response Technology	Enabled Disabled	Enable/Disable Smart Response Technology.

USB Configuration

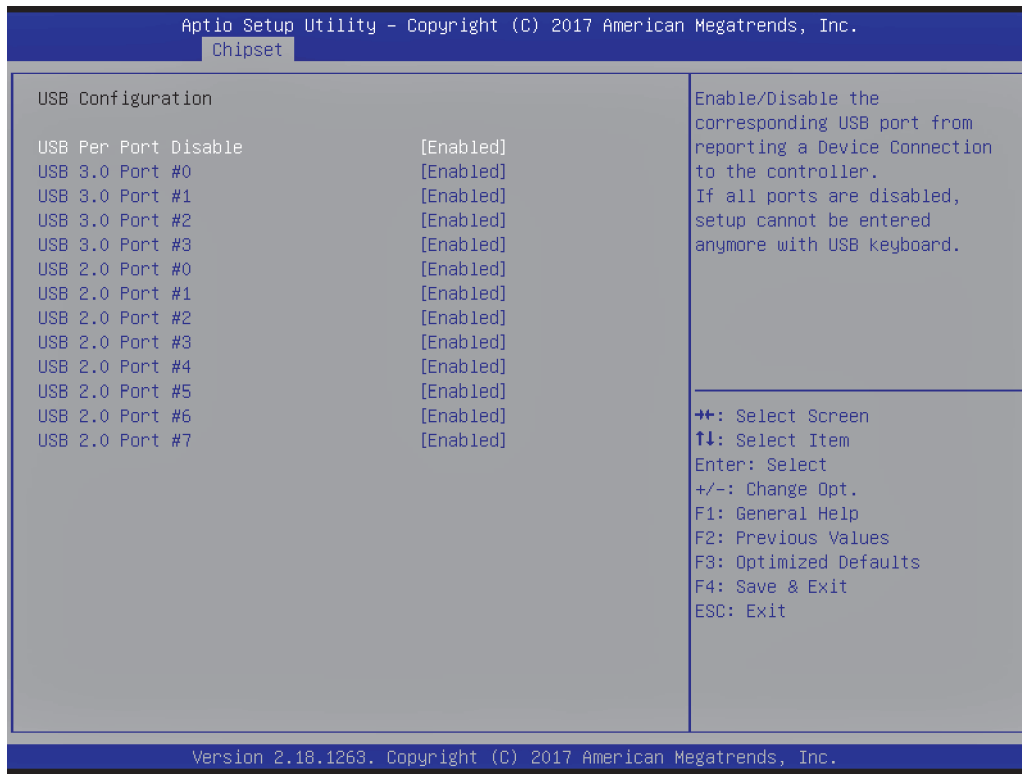

Parameter	Value	Comment
USB Per-Port Disable	Enabled Disabled	Enable/Disable the corresponding USB port from reporting a Device Connection to the controller. If all ports are disabled, setup cannot be entered anymore with USB keyboard.
USB Port	Enabled Disabled	Enable/Disable USB Port.

Security



Parameter	Value	Comment
Administrator Password		Set Administrator Password.
User Password		Set User Password.
User Password Policy	Setup Boot Boot + Setup	Setup: Password is necessary to enter Setup. Boot: Password is needed for starting system. If Administrator Password is also active, Setup can only be entered with Administrator Password. Boot+Setup: Password needed during POST, enter setup with User Password possible.
HDD Security	Submenu	HDD Security Configuration for selected drive.
Secure Boot	Submenu	Customizable Secure Boot settings

HDD Security Configuration

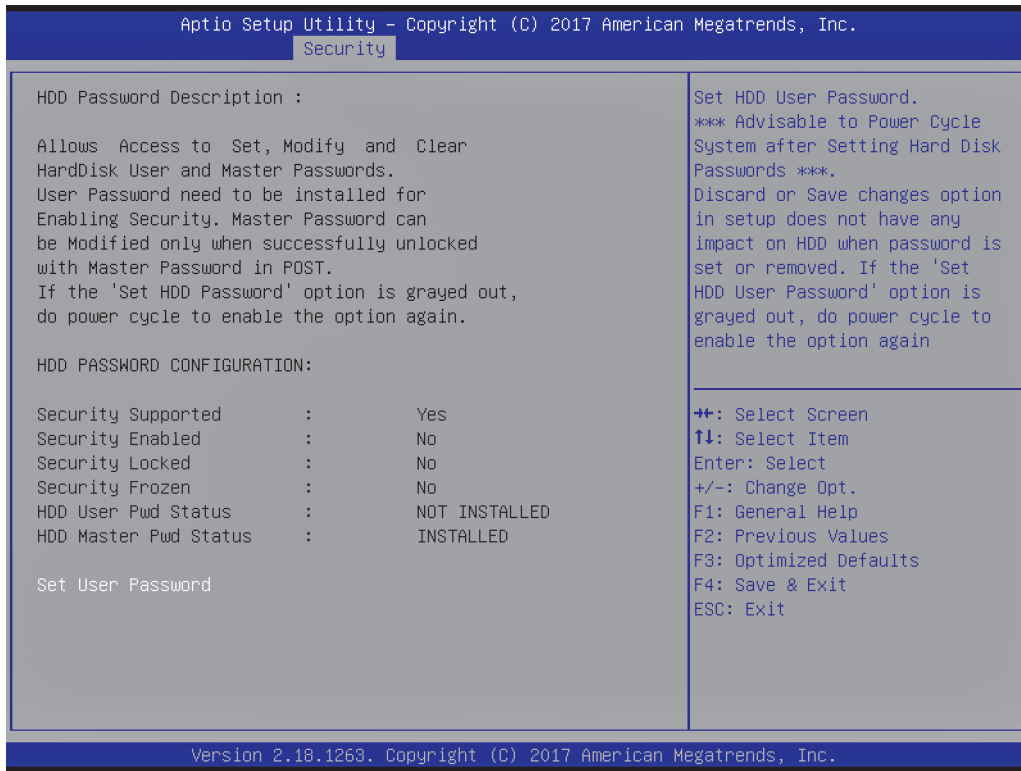

Parameter	Value	Comment
Set User Password		Set HDD User Password.

Secure Boot Configuration

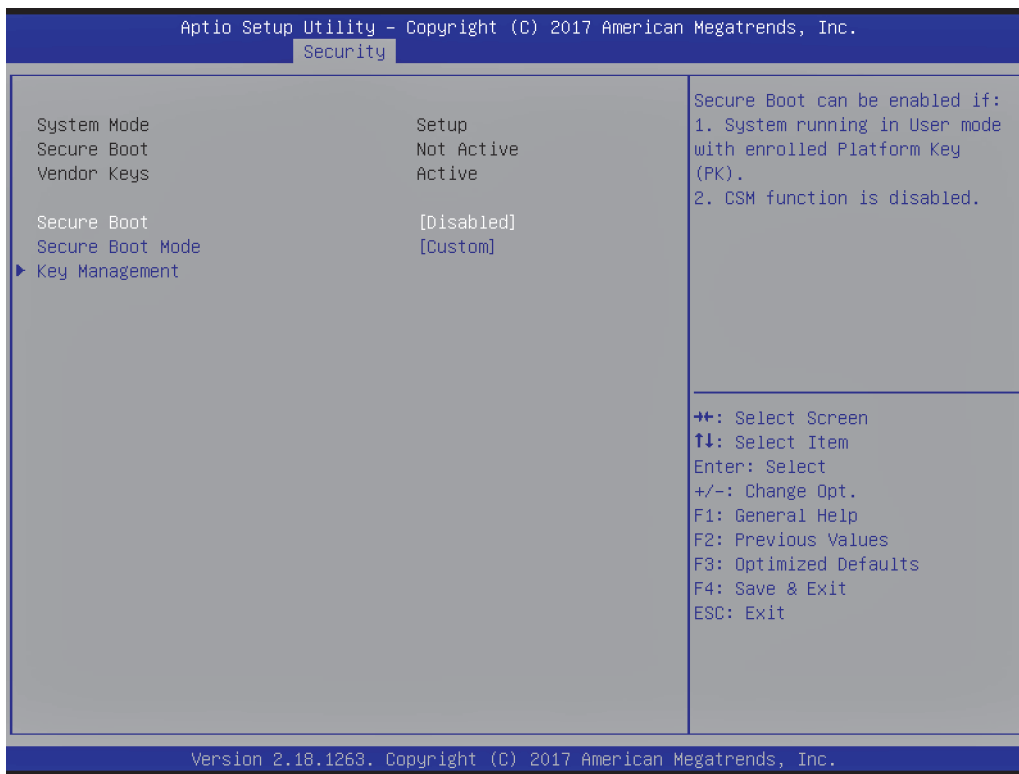

Parameter	Value	Comment
Secure Boot	Enabled Disabled	Secure Boot can be enabled if: 1. System running in User mode with enrolled Platform Key(PK). 2. CSM function is disabled.
Secure Boot Mode	Standard Custom	Secure Boot mode selector: In Custom mode Secure Boot Variables can be configured without authentication.
Key Management	Submenu	Enables expert users to modify Secure Boot Policy variables without full authentication.

Key Management

Note: Default Secure Boot Keys PK and KEK should updated by OEM PK and KEK Keys.

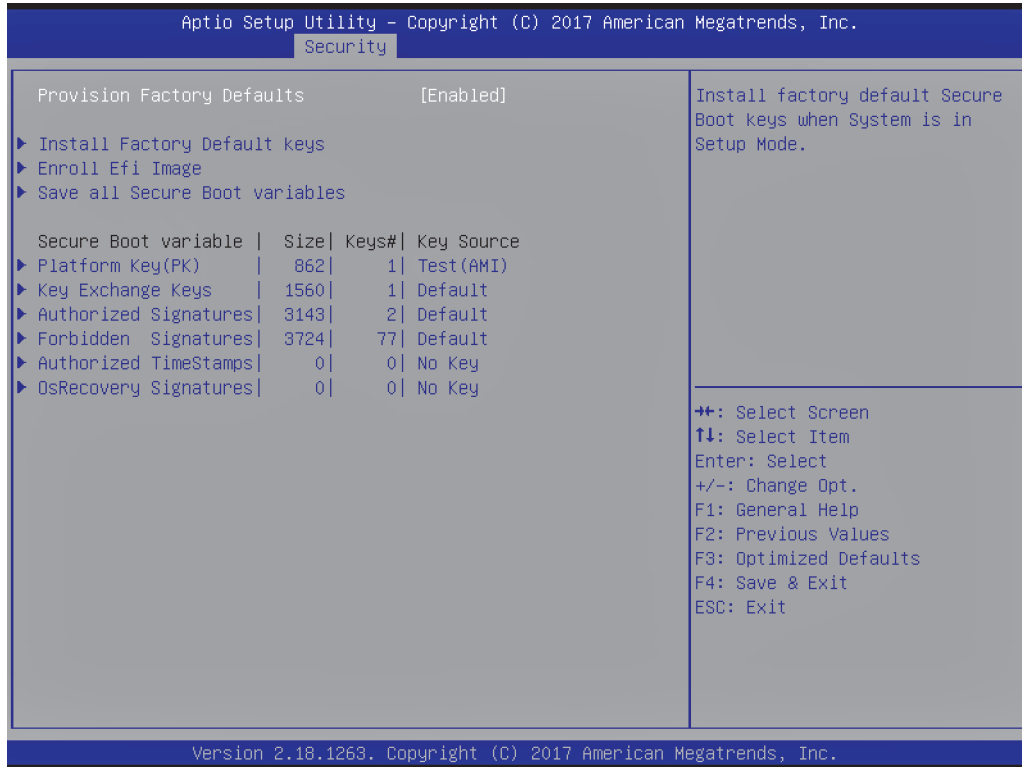

Parameter	Value	Comment
Provision Factory Default keys	Enabled Disabled	Install factory default Secure Boot keys when System is in Setup Mode.
Reset to Setup Mode	Function Key	Force System to Setup Mode - clear all Secure Boot Variables.
Install Factory Default keys	Function Key	Force System to User Mode - install all Factory Default keys.
Save all Secure Boot variables	Function Key	Save NVRAM content of all Secure Boot policy variables to the files (EFI_SIGNATURE_LIST data format) in root folder on a target file system device.
Platform Key (PK)	Function Key	Enroll Factory Defaults or load certificates from a file: 1. Public Key Certificate in: a)EFI_SIGNATURE_LIST b)EFI_CERT_X509 (DER encoded) c)EFI_CERT_RSA2048 (bin) d)EFI_CERT_SHA256 (bin) 2. Authenticated UEFI Variable 3. EFI PE/COFF Image (SHA256) Key source: Default, External, Mixed, Test
Key Exchange Keys	Function Key	
Authorized Signatures	Function Key	
Forbidden Signatures	Function Key	
Authorized TimeStamps	Function Key	
OsRecovery Signatures	Function Key	

Boot

Device Based

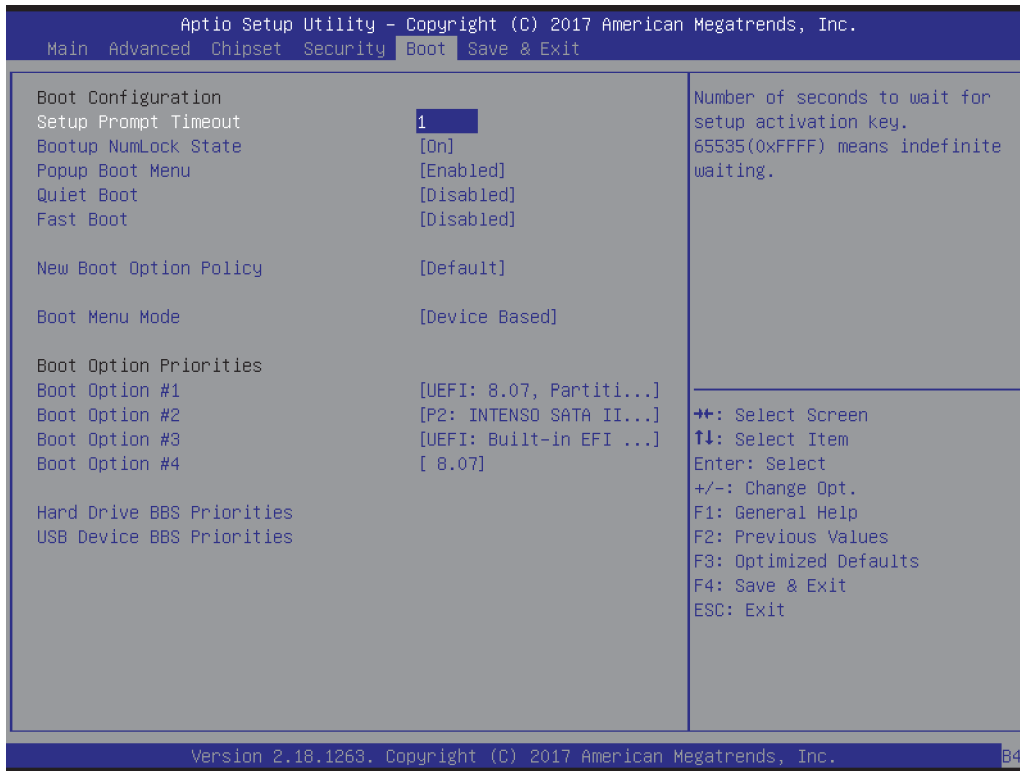

Parameter	Value	Comment
Setup Prompt Timeout	1 ... 65535 (1 default)	Number of seconds to wait for setup activation key. 65535(0xFFFF) means indefinite waiting.
Bootup NumLock State	On Off	Select the keyboard NumLock state.
Popup Boot Menu	Enabled Disabled	Enable/Disable Popup Boot Menu.
Quiet Boot	Enabled Disabled	Enables or Disables Quiet Boot option.
Fast Boot	Enabled Disabled	Enables/Disables boot with initialization of a minimal set of devices required to launch active boot option.
SATA Support	Last Boot HDD Only All Sata Devices	Select if only last HDD booted or all SATA HDD should be initialized.
VGA Support	Auto EFI Driver	If Auto, only install Legacy OpROM with Legacy OS. Logo would NOT be shown during post. Efi driver will still be installed with EFI OS.
USB Support	Disabled Full Initial Partial Initial	If Disabled, all USB devices will NOT be available until OS boot. If Partial Initial, USB Mass Storage and specific USB port/device will NOT be available before OS boot. If Enabled, all USB devices will be available in OS and Post.
PS2 Device Support	Enabled Disabled	If Disabled, PS2 devices will be skipped.
Network Stack Driver Support	Enabled Disabled	If Disabled, Network Stack Driver will be skipped.
Redirection Support	Enabled Disabled	If Disabled, Redirection function will be disabled.
New Boot Option Policy	Default Place First Place Last	Controls the placement of newly detected UEFI boot options.
Boot Menu Mode	Device Based Port Based	Device: Choose Boot Option by Device, Port: Choose Boot Option by Type. Need to reset and enter setup again for changes.

Parameter	Value	Comment
Boot Option Priorities	Depends on recognized device	Sets the boot order. Priority of devices from same type can be selected in BBS priority menus.
Hard Drive BBS Priorities	Submenu	Set the order of the legacy devices in this group. Content depend on recognized devices.
USB Device BBS Priorities	Submenu	Set the order of the legacy devices in this group. Content depend on recognized devices.

Port Based

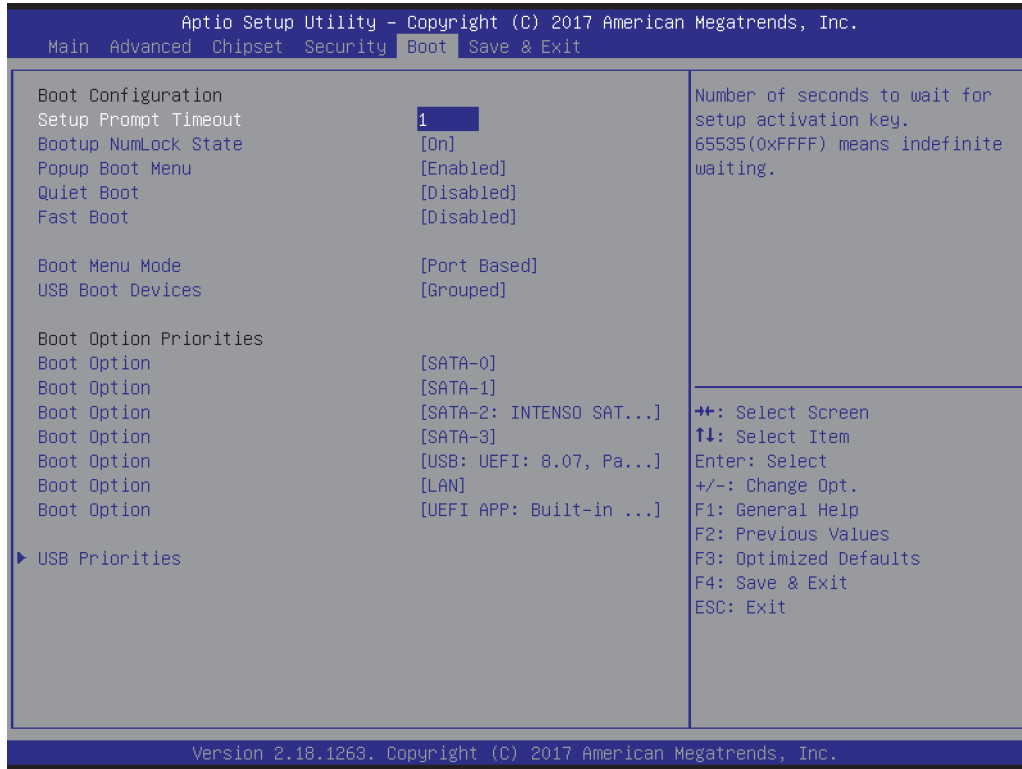

Parameter	Value	Comment
USB Boot Devices	Grouped By Port	Show all USB Boot Devices in one group or show all USB Ports.
Boot Option Priorities	Depends on recognized device	Sets the boot order. Priority of devices from same type can be selected in Priority Submenus.
USB Priorities	Submenu	Set the order of the devices in this group. Content depend on recognized devices.

Save & Exit

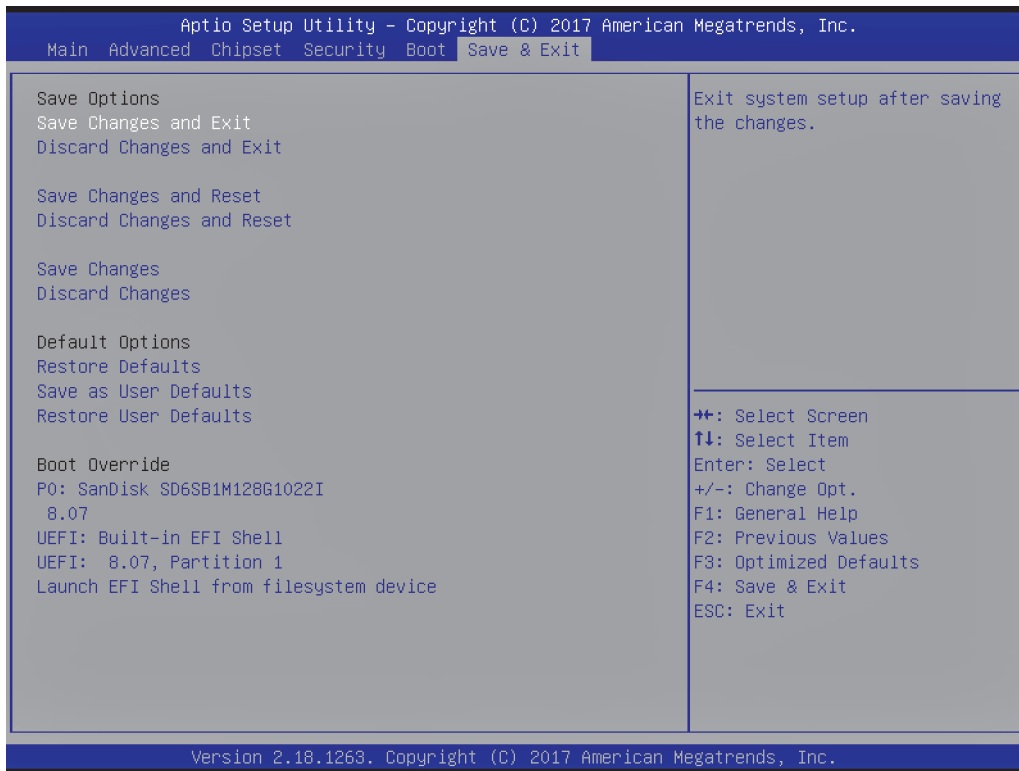

Parameter	Value	Comment
Save Changes and Exit	Function Key	Exit system setup after saving the changes.
Discard Changes and Exit	Function Key	Exit system setup without saving any changes.
Save Changes and Reset	Function Key	Reset the system after saving the changes.
Discard Changes and Reset	Function Key	Reset system setup without saving any changes.
Save Changes	Function Key	Save Changes done so far to any of the setup options.
Discard Changes	Function Key	Discard Changes done so far to any of the setup options.
Restore Defaults	Function Key	Restore/Load Default values for all the setup options.
Save as User Defaults	Function Key	Save the changes done so far as User Defaults.
Restore User Defaults	Function Key	Restore the User Defaults to all the setup options.
Boot Override	Depends on recognized device	Boots to selected device.
Launch EFI Shell from filesystem device	Function Key	Attempts to Launch EFI Shell application (Shell.efi) from one of the available filesystem devices.

This page intentionally left blank.



Headquarters:

DATA MODUL AG

Landsberger Str. 322
DE-80687 Munich - Germany
Phone: +49-89-56017-0
Fax: +49-89-56017-119
www.data-modul.com

Logistics, Production & Services:

DATA MODUL Weikersheim GmbH

Lindenstrasse 8
DE-97990 Weikersheim - Germany
Phone: +49-7934-101-0
Fax: +49-7934-101-101

Subsidiaries & Sales Offices:

Germany – Hamburg
Germany – Duesseldorf
Denmark
Dubai
Finland/Baltic
France
Italy
Singapore
Spain
Switzerland
UK
USA

DATA MODUL's worldwide offices

can be found on our website:
[www.data-modul.com/eu/sm/
contact-us/offices.html](http://www.data-modul.com/eu/sm/contact-us/offices.html)

