

eMotionUHD-II

Product Specification

This document might be changed without prior notice

12030612 eMotionUHD-II (Industrial)

12032701 eMotionUHD-II-G (Gaming)

Revision: 006

Date: 2024-02-12

Revision History

Rev.	Date	Author	Modifications
000	14.02.2018	R. Muhler	Initial revision
001	19.02.2018	M. Schmidt	Features added TCON Voltage +5V, +10V, +12V
002	26.04.2018	R. Muhler	Changed revision of IPC-A-610 to actual status
002	13.08.2018	R. Muhler	Only optical improvements, no changes
003	02.10.2018	R. Muhler	Pin X12-37 is now connected to D1-G20 (Chapter 4.6.1, 4.6.2) Molex-reference added for X7, X8.
004	24.01.2019	R. Muhler	Safety standards actualized, UL-requirements for PCB added (Chapter 7.3 and 9.2)
005	05.02.2021	R. Muhler	Correction on page 8: Jack plug for audio-out is 3.5mm (not 2.5mm)
006	12.02.2024	R. Muhler	Changes at DP and eDP descriptions

Table of contents

1. Preamble.....	6
1.1. <i>Purpose of this document</i>	6
1.2. <i>Abbreviations</i>	6
1.3. <i>Additional Documentation</i>	6
2. Product Description	7
2.1. <i>Functional description of the eMotionUHD-II</i>	7
2.2. <i>Background for development of eMotionUHD-II</i>	7
2.3. <i>Versions of eMotionUHD-II</i>	7
2.4. <i>Features of emotionUHD-II</i>	8
3. Outline Dimensions of eMotionUHD-II	9
3.1. <i>Drawing of PCB</i>	9
3.2. <i>Dimensions of PCB</i>	10
3.3. <i>Connector Panel</i>	10
3.4. <i>Connector Positions</i>	11
4. Connectors on eMotionUHD-II	12
4.1. <i>Power Input</i>	12
4.1.1 X1, Power Input (High Current Connector)	12
4.1.2 X2, Power Input (DC Jack).....	12
4.1.3 X3, Power Input (Internal Power)	13
4.2. <i>X4, External Load Switch and Analog Poti</i>	13
4.3. <i>Backlight Connector</i>	14
4.3.1 X5, Backlight Connector 1.....	14
4.3.1 X6, Backlight Connector 2.....	14
4.4. <i>Display-Port (DP1.2 compliant)</i>	15
4.4.1 X7, DP-1	15
4.4.2 X8, DP-2	16
4.5. <i>HDMI-Port</i>	17
4.5.1 X9, HDMI-1	17
4.5.2 X10, HDMI-2	18
4.5.3 X11, HDMI-1 internal (optional)	19
4.6. <i>Display Connector</i>	20
4.6.1 X12, VBO out.....	20
4.6.2 X12, eDP out	22
4.6.3 X13, LVDS-output (optional)	24
4.7. <i>X14, Brightness Keys and external ON-Signal (optional)</i>	25
4.8. <i>X15, uC CAN and LED-Control (optional)</i>	25
4.9. <i>X16, Buzzer (optional)</i>	25
4.10. <i>X17, USB Link-Select (optional)</i>	26

- 4.11. X18, STM32 Debug & ISP Header (optional)26
- 4.12. X19, STM32 Boot Select Jumper (optional).....26
- 4.13. X20, PWM Fan (option).....26
- 4.14. X21, System-Bus (I2C 3V3 Level).....27
- 4.15. X22, System-Bus (I2C 5V Level).....27
- 4.16. X23, RS232 uC UART (optional)27
- 4.17. X24, RS232 Scaler UART28
- 4.18. X25, USB Firmware update.....28
- 4.19. X26, USB Communication (optional)28
- 4.20. X27, TCON Voltage selection jumper (optional)29
- 4.21. X28, Signal Routing for VBO / eDP output29
- 4.22. X35, Signal Routing for VBO / eDP output29
- 4.23. X29, OSD-Keyboard-Connector.....30
- 4.24. X30, Analog Audio Line-Out L/R30
- 4.25. X31, Digital Audio Out.....31
- 4.26. X32, Backlight-Dimming-Level select31
- 4.27. X33, Backlight-Enable-Level Select32
- 4.28. X34, Backlight-Enable-Polarity Select.....32
- 4.29. X42, TCON power33
- 5. Technical Details34**
 - 5.1. Block Diagram.....34
 - 5.2. Supply Voltages and Current Consumption35
 - 5.3. TCON Voltage35
 - 5.4. Input and Output Signals.....36
 - 5.4.1 DP Input36
 - 5.4.2 HDMI Input36
 - 5.4.3 Vx1 Output36
 - 5.4.4 eDP Output.....36
- 6. Optional Features for Ship Displays37**
 - 6.1. Fan Speed Control37
 - 6.2. External Brightness Key.....37
 - 6.3. External Brightness Poti37
 - 6.4. External ON/OFF Signal37
 - 6.5. Internal Buzzer37
 - 6.6. External Buzzer.....37
 - 6.7. USB-Link-Select37
 - 6.8. Data Modul Backlight Inverter37
 - 6.9. ALC Sensor.....37
 - 6.10. RS23237
- 7 Qualification.....38**

- 7.1 Environmental conditions38
- 7.2 EMI-Standards38
 - 7.2.1 EMC/EMI-Standards38
- 7.3 Safety38
- 7.4 Shock and Vibration.....39
- 7.5 Reliability, MTBF39
- 8 Warranty, Quality and Environmentalism39**
 - 8.1 Warranty39
 - 8.2 Quality.....39
 - 8.3 Environmentalism39
- 9 Label and PCB markings40**
 - 9.1 Label and Material Number40
 - 9.2 Marking of PCB40

1. Preamble

1.1. Purpose of this document

In this document the technical parameters, the electrical connections and the mechanical dimensions of the DATA MODUL scaler board eMotionUHD-II are described.

The eMotionUHD-II scaler board can drive panels up to UHD solution (i.e. 3840 x 2160 @60Hz).

1.2. Abbreviations

UHD	ULTRA HIGH DEFINITION
I²C	INTER-IC
EDP	EMBEDDED DISPLAY PORT
EMI	ELECTRO MAGNETIC INTERFERENCE
EMC	ELECTRO MAGNETIC COMPATIBILITY
EN	EUROPEAN NORM
ESD	ELECTRO STATIC DISCHARGE
UL	UNDERWRITER LAB
PCB	PRINTED CIRCUIT BOARD
SMT	SURFACE MOUNT TECHNOLOGY
ROHS	RESTRICTION FOR THE USE OF HAZARDOUS SUBSTANCES
NC	NOT CONNECTED
TBD	TO BE DEFINED
TMDS	TRANSITION MINIMIZED DIFFERENTIAL SIGNALING
DVI	DIGITAL VIDEO INTERFACE
DP	DISPLAY PORT
EDP	EMBEDDED DISPLAY PORT
RBR	REDUCED BIT RATE (1.62 GBIT/S PER LANE)
HBR	HIGH BIT RATE (2.7 GBIT/S PER LANE)
HBR2	HIGH BIT RATE 2 (5.4 GBIT/S PER LANE)
HDMI	HIGH DEFINITION MULTIMEDIA INTERFACE
OSD	ON SCREEN DISPLAY
DPMS	DISPLAY POWER MANAGEMENT SYSTEM
VESA	VIDEO ELECTRONICS STANDARDS ASSOCIATION
DDC / CI	DISPLAY DATA CHANNEL / COMANND INTERFACE
USB	UNIVERSAL SERIAL BUS
UART	UNIVERSAL ASYNCHRONOUS RECEIVER TRANSMITTER
VBO	V-BY-ONE

1.3. Additional Documentation

TBD

2. Product Description

2.1. *Functional description of the eMotionUHD-II*

The eMotionUHD-II is a LCD controller board for industrial applications. By using the latest generation of suitable scaler-ICs the eMotionUHD-II board can be used to drive VBO-, eDP- and LVDS-panels.

The eMotionUHD-II can be controlled by OSD board as well as by IR remote. An additional control by RS232 and DDC/CI is possible.

2.2. *Background for development of eMotionUHD-II*

As market leader for visual solutions DATA MODUL offers amongst others interface cards for driving large size TFTs. As the market trends more and more to higher resolutions for the TFTs DATA MODUL eMotionUHD-II was designed to have a suitable LCD-controller for this market segment.

2.3. *Versions of eMotionUHD-II*

The eMotionUHD-II board is available in 2 versions which can be ordered by a different article number

12030612	eMotionUHD-II (Industrial)
12032701	eMotionUHD-II (Gaming)

The eMotionUHD-II (Gaming) is an assembly version of the eMotionUHD-II (Industrial). Some functions and connectors are not implemented or mounted. Connectors marked as optional are just assembled the eMotionUHD-II (industrial).

For details of additional features see chapter 6.

2.4. Features of emotionUHD-II

Scaler	NT68394G from Novatek
Input resolution	Up to UHD (4096x2160@60Hz)
Output resolution	FHD to UHD
Colors	24bit/30bit (1,07Bil.)
Power supply	Single power supply +24V DC
Backlight support	PWM dimming / analogue dimming (0...3.3V)
EMI	Onboard EMI filtering circuit Support SSC for reduce EMI (SSC = spread spectrum)
Operating temperature	0°C ...60°C
Inputs	2 x DisplayPort 1.2 support HDCP 1.4 (Compliance V1.2) and HDCP 2.2 2 x HDMI 2.0 support HDCP 1.4 (Compliance V1.2) and HDCP 2.2
Panel voltage	5.0V, 10.0, 12.0V (selectable with jumpers)
Backlight support	Analog & PWM dimming
Output	V-by-One (8 lanes) eDP: 2x eDP V1.4 PHY and 2x eDP V1.4 link, every eDP PHY/link support 1,2 or 4 lanes; supported link rate RBR, HBR, HBR2; AUX CH 1 Mbps Resolution up to 4096x2160@60Hz
LVDS output	JEIDA or VESA mapping with 6/8/10-bit Up to 1920 x 1200 on separate output connector
Picture in Picture	All combinations of all inputs can be displayed
Power safe mode	VESA DPMS compatible
DDC CI	Support of DDC/CI
Remote control	- RS232 remote control - 5 key OSD Keyboard - IR control by RECS80
Software update	- RS232 - DDC/CI-interface of HDMI-inputs (using USB-ISP board) - USB-port
Audio input	Integrated in DisplayPort- or HDMI-video-stream
Audio output	- Digital I ² S on separate output connector - Stereo line out on 3.5mm jack plug on connector panel
Temperature control	Onboard temperature sensor

3. Outline Dimensions of eMotionUHD-II

3.1. Drawing of PCB

Top view of eMotionUHD-II

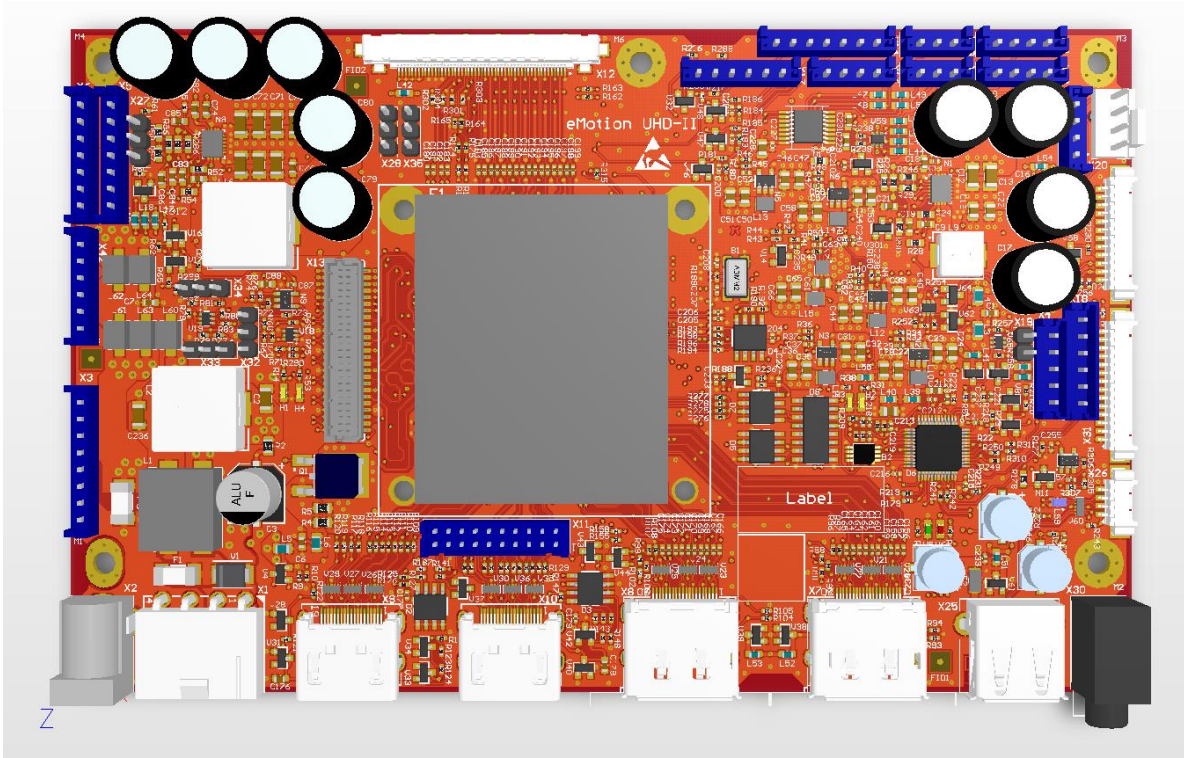

Bottom view of eMotionUHD-II

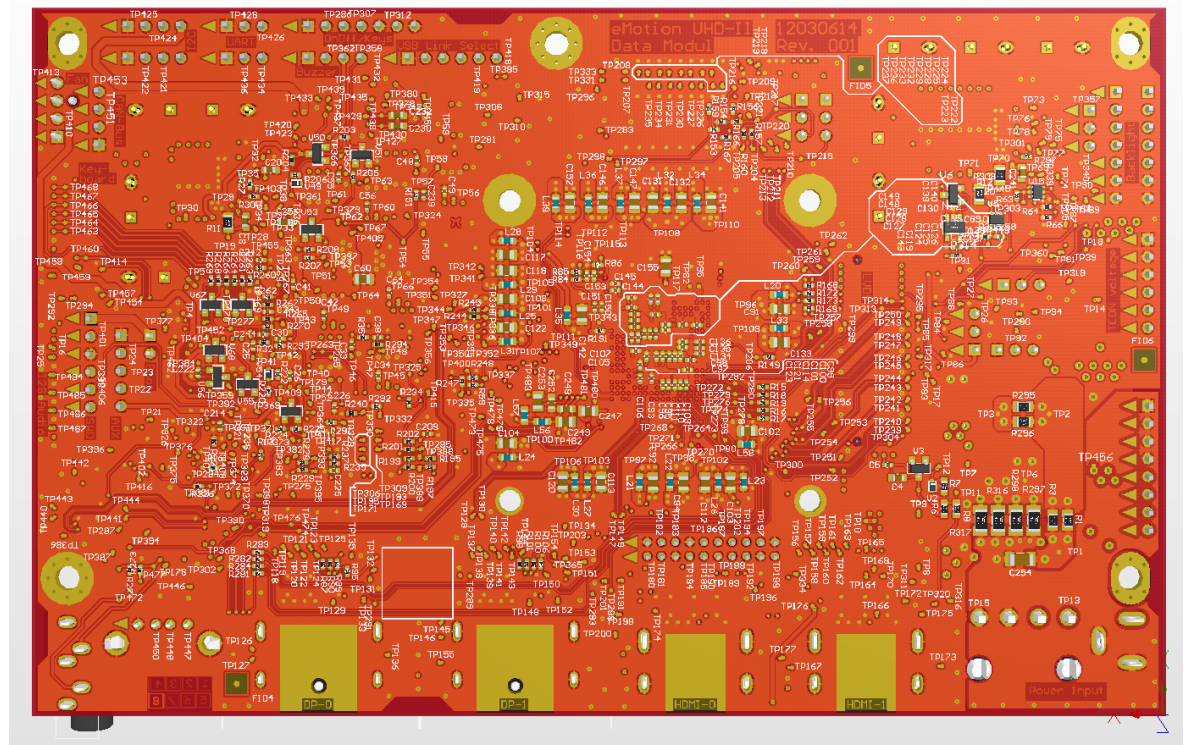

3.2. Dimensions of PCB

The dimensions of the eMotionUHD-II board are 100mm x 160mm.

It has 5 mounting holes M3

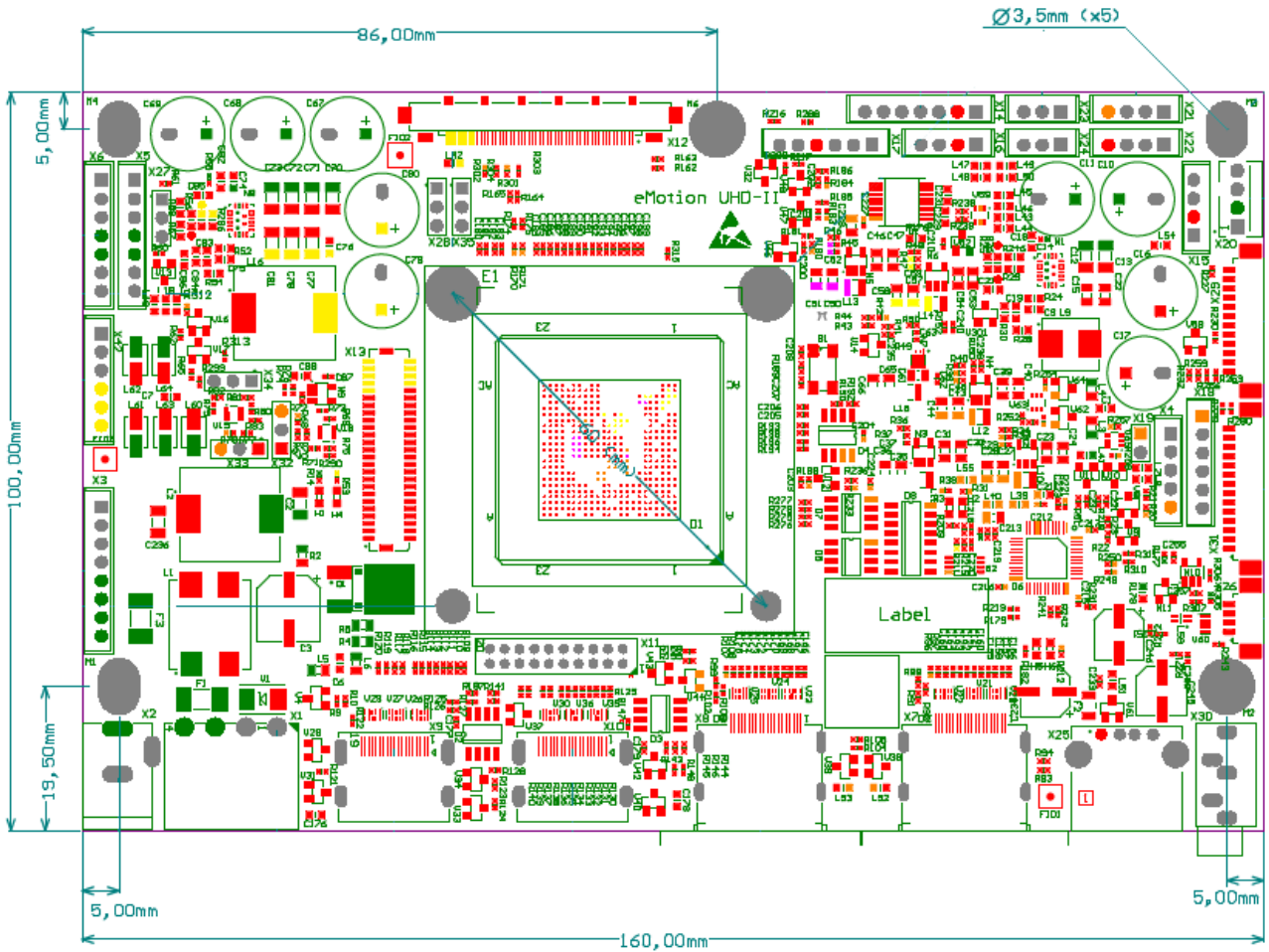

A drawing with detailed positions of all connectors is shown on next page

3.3. Connector Panel

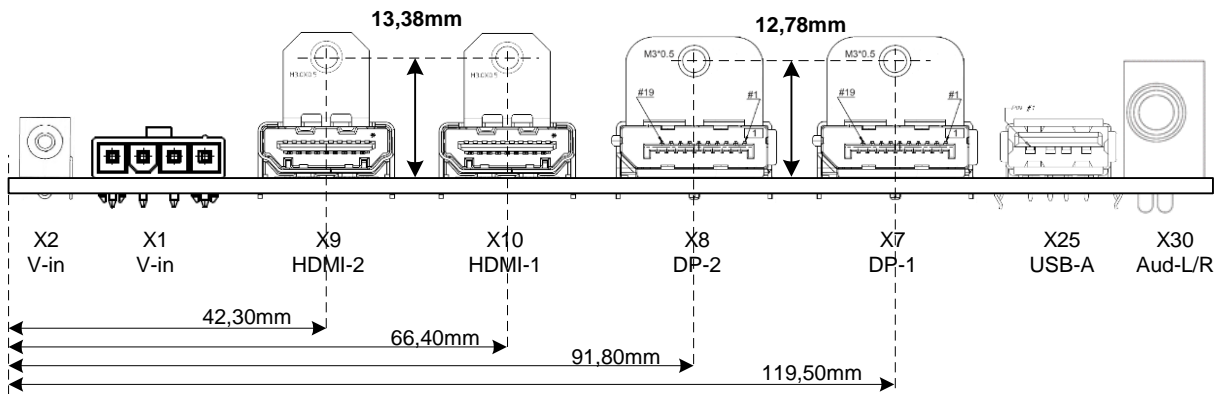

3.4. Connector Positions

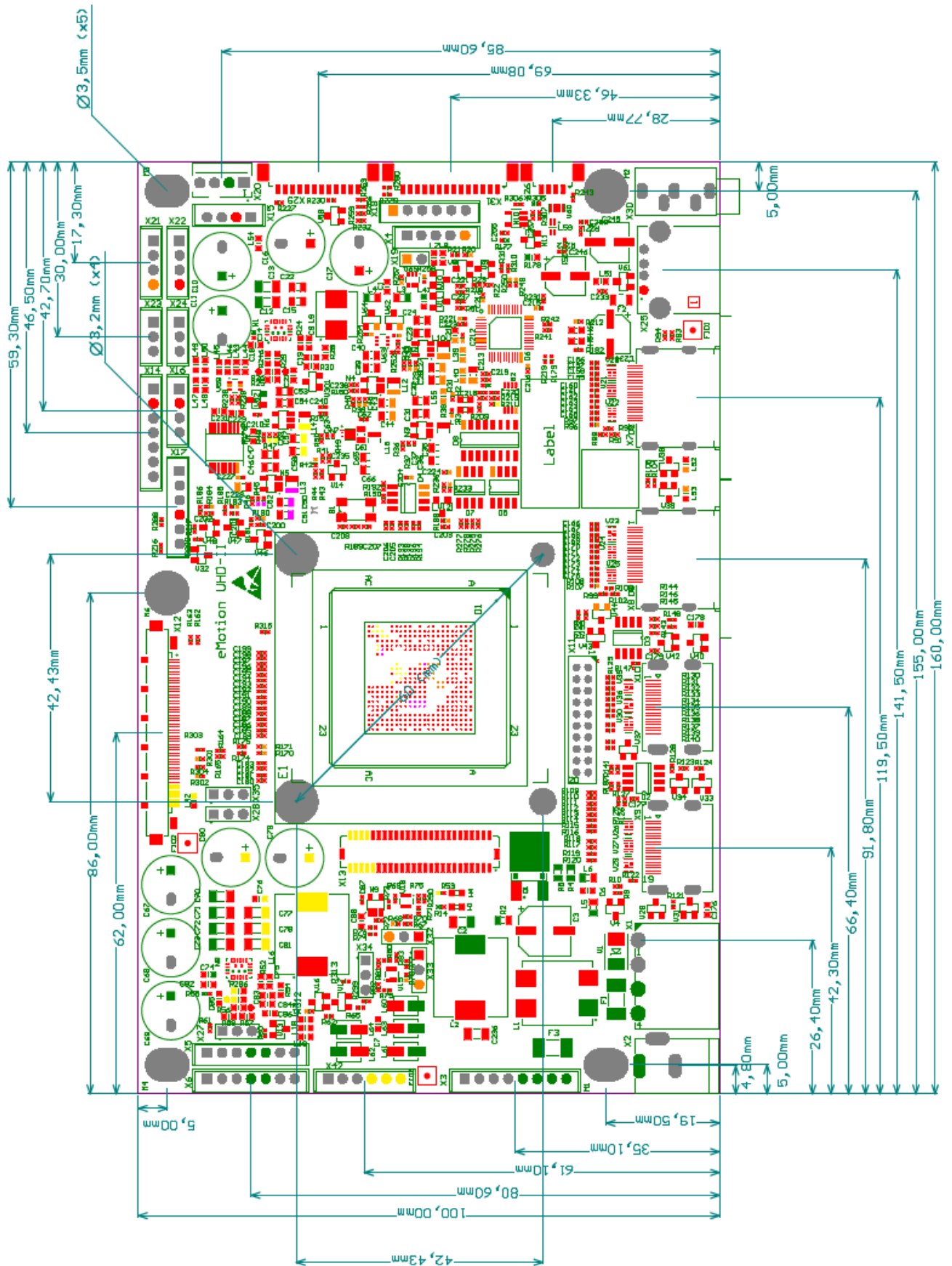

4. Connectors on eMotionUHD-II

The designator of each connector is visible on the silkscreen of eMotionUHD-II board. Connectors marked as option are not assembled on the emotionUHD-II (Gaming)

4.1. Power Input

For supply voltage input of eMotionUHD-II there are 3 different connectors implemented. X1 and X2 are placed at the connectors panel and X3 is placed for connecting supply voltage from inside of the monitor.

4.1.1 X1, Power Input (High Current Connector)

Type: Molex-Ref.-No: 0039303045

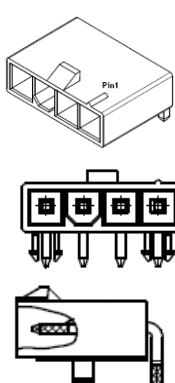
Pin arrangement	Pin	Signal	I/O	Description
 <p>Top- Front-, Side-View</p>	1	GND	I/O	GND
	2	GND	I/O	GND
	3	+Vin	I	+24V/4A*
	4	+Vin	I	+24V/4A*
				* 4A per pin / max. 8A on connector

4.1.2 X2, Power Input (DC Jack)

Type: W+P Products, W+P-No.: 649-2-2.5-20-5A

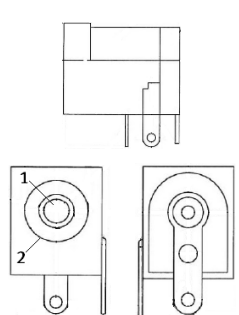
Pin arrangement	Pin	Signal	I/O	Description
 <p>Side-, Front-, Rear-View</p>	1	+Vin	I	+24V/5A
	2	GND	I/O	GND
	3	GND	I/O	GND

4.1.3 X3, Power Input (Internal Power)

Type: JST-Ref.-No. S8B-EH

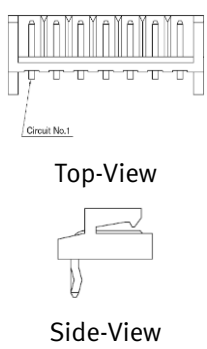
Pin arrangement	Pin	Signal	I/O	Description
 <p>Top-View</p> <p>Side-View</p>	1	GND		GND
	2	GND		GND
	3	GND		GND
	4	GND		GND
	5	+Vin		+24V DC / max. 3A per pin
	6	+Vin		+24V DC / max. 3A per pin
	7	+Vin		+24V DC / max. 3A per pin
	8	+Vin		+24V DC / max. 3A per pin

4.2. X4, External Load Switch and Analog Poti

This connector can be used to switch an external load switch (e.g. for TCON- or backlight-supply) or to drive an external buzzer.

Type: JST-Ref.-No. B5B-EH

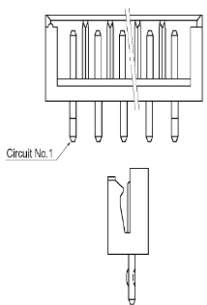
Pin arrangement	Pin	Signal	I/O	Description
	1	GND		GND
	2	AUX_LOAD_SWITCH_ADC2	0	ADC2 IN / ex. Buzzer detect
	3	AUX_LOAD_SWITCH_ADC1		ADC1 IN / ex. Buzzer enable
	4	AUX_LOAD_SWITCH_EN		AUX_LOAD_SWITCH_EN
	5	+3V3_STBY		+3V3

4.3. Backlight Connector

For driving the backlight inverter there are 2 connectors on eMotionUHD-II. Both connectors are routed in parallel. Both connectors should be used, if the driving current for backlight inverter is too high for one connector.

Maximum output current for backlight operating voltage is limited by fuse to 8A!

4.3.1 X5, Backlight Connector 1

Type: JST-Ref.-No. B7B-EH

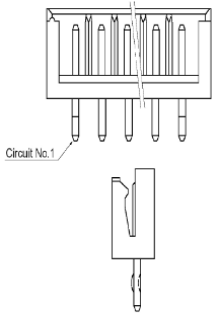
Pin arrangement	Pin	Signal	I/O	Description
	1	ADIM*	O	Analog dimming voltage*
	2	PWM*	O	PWM diming output*
	3	EN**	O	ON/OFF **
	4	VDD***	O	Operating voltage +24V***
	5	VDD***	O	Operating voltage +24V***
	6	GND	I/O	GND
	7	GND	I/O	GND

4.3.1 X6, Backlight Connector 2

Type: JST-Ref.-No. B7B-EH

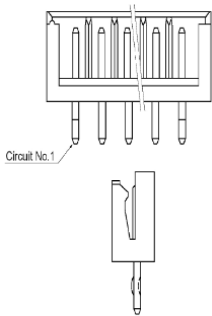
Pin arrangement	Pin	Signal	I/O	Description
	1	ADIM*	O	Analog dimming voltage*
	2	PWM*	O	PWM diming output*
	3	EN**	O	ON/OFF **
	4	VDD***	O	Operating voltage +24V***
	5	VDD***	O	Operating voltage +24V***
	6	GND	I/O	GND
	7	GND	I/O	GND

*: range of ADIM-signal and level of PWM-signal can be set by jumper on X32

** : level and polarity of EN-signal can be set by jumpers on X33, X34

***: max. current per pin is 3A, for all pins together 8A must not be exceeded

4.4. Display-Port (DP1.2 compliant)

The eMotionUHD-II has 2 DisplayPort inputs. Both inputs are DP1.2 compatible.

4.4.1 X7, DP-1

Type: Nexus: 3662-FA-R (Molex reference: 47272-1004)

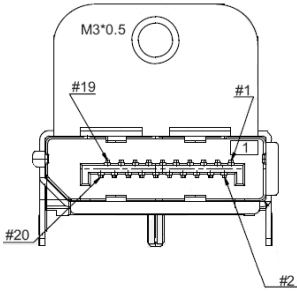
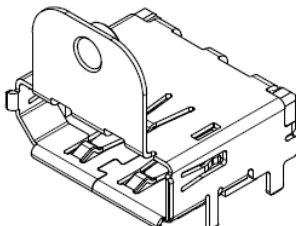
Pin arrangement	Pin	Signal	I/O	Description
 <p>Front-View</p> 	1	ML_L3N	I	Main Link Ch. 3 Differential Input negative
	2	GND		GND
	3	ML_L3P	I	Main Link Ch. 3 Differential Input positive
	4	ML_L2N	I	Main Link Ch. 2 Differential Input negative
	5	GND		GND
	6	ML_L2P	I	Main Link Ch. 2 Differential Input positive
	7	ML_L1N	I	Main Link Ch. 1 Differential Input negative
	8	GND		GND
	9	ML_LN1P	I	Main Link Ch. 1 Differential Input positive
	10	ML_LN0N	I	Main Link Ch. 0 Differential Input negative
	11	GND		GND
	12	ML_LN0P	I	Main Link Ch. 0 Differential Input positive
	13	Config 1	O	Config Pin1, connect to GND with 1M
	14	Config 2	O	Config Pin2, connect to GND with 1M
	15	AUXP	I	Auxiliary Ch. Differential Input positive
	16	GND		GND
	17	AUXN	I	Auxiliary Ch. Differential Input negative
	18	HPD	I/O	Hot Plug Detect
	19	POR	I/O	Connect to GND
	20	PO	O	Not Connected to internal circuits

4.4.2 X8, DP-2

Type: Nexus: 3662-FA-R (Molex reference: 47272-1004)

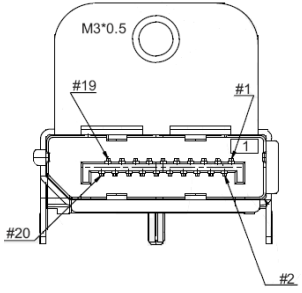
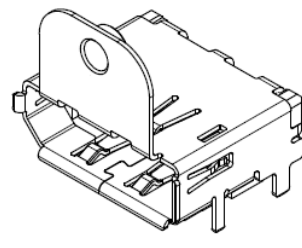
Pin arrangement	Pin	Signal	I/O	Description
 <p>Front-View</p> 	1	ML_L3N	I	Main Link Ch. 3 Differential Input negative
	2	GND		GND
	3	ML_L3P	I	Main Link Ch. 3 Differential Input positive
	4	ML_L2N	I	Main Link Ch. 2 Differential Input negative
	5	GND		GND
	6	ML_L2P	I	Main Link Ch. 2 Differential Input positive
	7	ML_L1N	I	Main Link Ch. 1 Differential Input negative
	8	GND		GND
	9	ML_LN1P	I	Main Link Ch. 1 Differential Input positive
	10	ML_LN0N	I	Main Link Ch. 0 Differential Input negative
	11	GND		GND
	12	ML_LN0P	I	Main Link Ch. 0 Differential Input positive
	13	Config 1	O	Config Pin1, connect to GND with 1M
	14	Config 2	O	Config Pin2, connect to GND with 1M
	15	AUXP	I	Auxiliary Ch. Differential Input positive
	16	GND		GND
	17	AUXN	I	Auxiliary Ch. Differential Input negative
	18	HPD	I/O	Hot Plug Detect
	19	POR	I/O	Connect to GND
	20	PO	O	Not Connected to internal circuits

4.5. HDMI-Port

The eMotionUHD-II has 2 HDMI inputs. Both inputs are HDMI 2.0 compatible

4.5.1 X9, HDMI-1

Type: W&P 8800-19-2-2-1-70, Molex-Ref.-No. 47151-0002

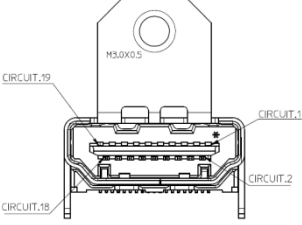
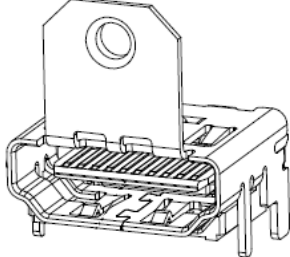
Pin arrangement	Pin	Signal	I/O	Description
 <p>Front-View</p> 	1	RX2+	In	TMDS Data2+
	2	GND		TMDS Data2 Shield
	3	RX2-	In	TMDS Data2-
	4	RX1+	In	TMDS Data1+
	5	GND		TMDS Data1 Shield
	6	RX1-	In	TMDS Data1-
	7	RX0+	In	TMDS Data0+
	8	GND		TMDS Data0 Shield
	9	RX0-	In	TMDS Data0-
	10	RXC+	In	TMDS Data-Clock+
	11	GND		TMDS Data-Clock Shield
	12	RXC-	In	TMDS Data-Clock-
	13	CEC		CEC
	14	NC		No internal Connection
	15	DSCL	In	I2C-Clock, +5V level
	16	DSDA	I/O	I2C-Data, +5V level
	17	GND		DDC/CEC-GND
	18	HDMIHOT	In	+5V Power
	19	HOTPLUG	Out	Hot Plug Detect Signal

4.5.2 X10, HDMI-2

Type: W&P 8800-19-2-2-1-70, Molex-Ref.-No. 47151-0002

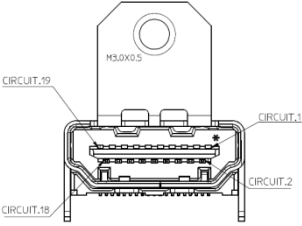
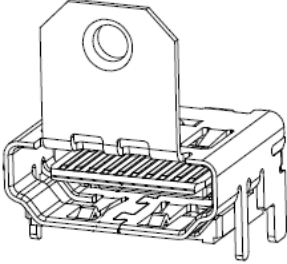
Pin arrangement	Pin	Signal	I/O	Description
 <p>Front-View</p> 	1	RX2+	In	TMDS Data2+
	2	GND		TMDS Data2 Shield
	3	RX2-	In	TMDS Data2-
	4	RX1+	In	TMDS Data1+
	5	GND		TMDS Data1 Shield
	6	RX1-	In	TMDS Data1-
	7	RX0+	In	TMDS Data0+
	8	GND		TMDS Data0 Shield
	9	RX0-	In	TMDS Data0-
	10	RXC+	In	TMDS Data-Clock+
	11	GND		TMDS Data-Clock Shield
	12	RXC-	In	TMDS Data-Clock-
	13	CEC		CEC
	14	NC		No internal Connection
	15	DSCL	In	I2C-Clock, +5V level
	16	DSDA	I/O	I2C-Data, +5V level
	17	GND		DDC/CEC-GND
	18	HDMIHOT	In	+5V Power
	19	HOTPLUG	Out	Hot Plug Detect Signal

4.5.3 X11, HDMI-1 internal (optional)

This connector is for internal wiring of HDMI-signals. It is routed in parallel to X10 and is only an option. In case of mounting X11 connector X10 will not be mounted.

Type: JST B20B-PHDSS

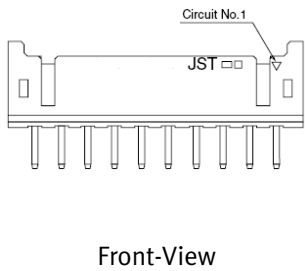
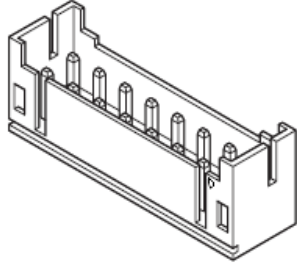
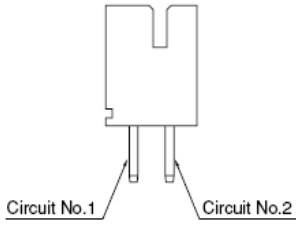
Pin arrangement	Pin	Signal	I/O	Description
  	1	RX2+	In	TMDS Data2+
	2	GND		TMDS Data2 Shield
	3	RX2-	In	TMDS Data2-
	4	RX1+	In	TMDS Data1+
	5	GND		TMDS Data1 Shield
	6	RX1-	In	TMDS Data1-
	7	RX0+	In	TMDS Data0+
	8	GND		TMDS Data0 Shield
	9	RX0-	In	TMDS Data0-
	10	RXC+	In	TMDS Data-Clock+
	11	DET		TMDS Data-Clock Shield
	12	RXC-	In	TMDS Data-Clock-
	13	CEC		CEC
	14	NC		No internal Connection
	15	DSCL	In	I2C-Clock, +5V level
	16	DSDA	I/O	I2C-Data, +5V level
	17	GND		DDC/CEC-GND
	18	HDMIHOT	In	+5V Power
	19	HOTPLUG	Out	Hot Plug Detect Signal
	20	Shield		

4.6. Display Connector

This connector is used for driving TFTs with V-by-One- or eDP-input on TCON-board. The type of output signal (V-by-One or eDP) can be configured by firmware. Additionally, the jumpers on X28, X35 have to be considered.

For driving TFTs with LVDS-input a separate connector is available (X13).

4.6.1 X12, VBO out

The pinning of X12 matches with V-by-One displays from LGD, AUO and InnoLux. A 51pin-FFC-cable can be used to drive these TFTs.

Type: JAE FI-RE51S-HF

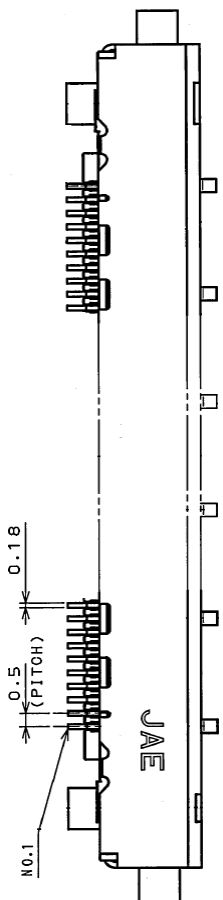
Pin arrangement	Pin	Signal	I/O	Description
 <p>Top-View</p>	1	GND		GND
	2	VTX_TX7P	O	V-by-One data lane7 positive
	3	VTX_TX7N	O	V-by-One data lane7 negative
	4	GND		GND
	5	VTX_TX6P	O	V-by-One data lane6 positive
	6	VTX_TX6N	O	V-by-One data lane6 negative
	7	GND		GND
	8	VTX_TX5P	O	V-by-One data lane5 positive
	9	VTX_TX5N	O	V-by-One data lane5 negative
	10	GND		GND
	11	VTX_TX4P	O	V-by-One data lane4 positive
	12	VTX_TX4N	O	V-by-One data lane4 negative
	13	GND		GND
	14	VTX_TX3P	O	V-by-One data lane3 positive
	15	VTX_TX3N	O	V-by-One data lane3 negative
	16	GND		GND
	17	VTX_TX2P	O	V-by-One data lane2 positive
	18	VTX_TX2N	O	V-by-One data lane2 negative
	19	GND		GND
	20	VTX_TX1P	O	V-by-One data lane1 positive
	21	VTX_TX1N	O	V-by-One data lane1 negative
	22	GND		GND
	23	VTX_TX0P	O	V-by-One data lane0 positive
	24	VTX_TX0N	O	V-by-One data lane0 negative
	25	GND		GND
	26	VTX_PLL_LOCK	O	VTX PLL Lock
	27	VTX_HPD	I	VTX Hot Plug Detection
	28	NC / GND		NC (default) / GND (assembly option)

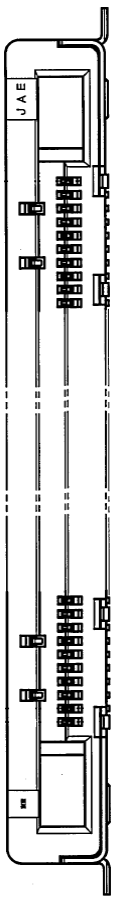
 <p>Side-View</p>	29	GPIO / NC	I/O	GPIO (default) Transistor switch / NC (assembly option)
	30	LD_EN	0	Local dimming enable (transistor switch)
	31	NC		NC
	32	NC		NC
	33	SCL / NC	0	I2C serial clock / NC (assembly option)
	34	SCA / NC	I/O	I2C serial data / NC (assembly option)
	35	LDC_ONOFF	0	LCD On/Off-signal
	36	NC		NC
	37	NC		NC
	38	GND / NC (option)		GND / NC (option)
	39	GND		GND
	40	GND		GND
	41	GND		GND
	42	GND		GND
	43	NC		
	44	+V_TCON	0	Panel Power (12V, 10V, 5V)
	45	+V_TCON	0	Panel Power (12V, 10V, 5V)
	46	+V_TCON	0	Panel Power (12V, 10V, 5V)
	47	+V_TCON	0	Panel Power (12V, 10V, 5V)
	48	+V_TCON	0	Panel Power (12V, 10V, 5V)
49	+V_TCON	0	Panel Power (12V, 10V, 5V)	
50	+V_TCON	0	Panel Power (12V, 10V, 5V)	
51	+V_TCON	0	Panel Power (12V, 10V, 5V)	

4.6.2 X12, eDP out

For connecting a TFT with eDP-input a cable with single wires has to be used, whereupon wires with the positive and negative signal of a lane have to be twisted. The scaler firmware has to configure to the correct type of output signals.

Type: JAE FI-RE51S-HF

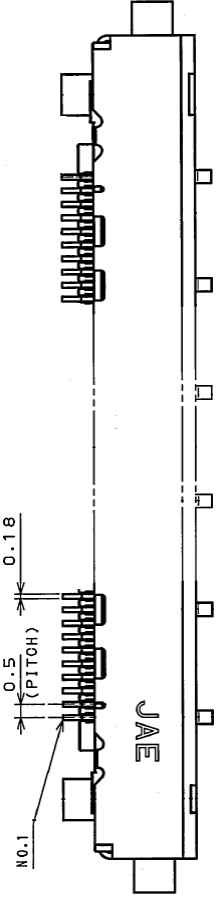
Pin arrangement	Pin	Signal	I/O	Description
 <p>Top-View</p>	1	GND		GND
	2	VTX_TX7P	O	2 nd eDP-Phy data lane3 positive
	3	VTX_TX7N	O	2 nd eDP-Phy data lane3 negative
	4	GND		GND
	5	VTX_TX6P	O	2 nd eDP-Phy data lane2 positive
	6	VTX_TX6N	O	2 nd eDP-Phy data lane2 negative
	7	GND		GND
	8	VTX_TX5P	O	2 nd eDP-Phy data lane1 positive
	9	VTX_TX5N	O	2 nd eDP-Phy data lane1 negative
	10	GND		GND
	11	VTX_TX4P	O	2 nd eDP-Phy data lane0 positive
	12	VTX_TX4N	O	2 nd eDP-Phy data lane0 negative
	13	GND		GND
	14	VTX_TX3P	O	1 st eDP-Phy data lane3 positive
	15	VTX_TX3N	O	1 st eDP-Phy data lane3 negative
	16	GND		GND
	17	VTX_TX2P	O	1 st eDP-Phy data lane2 positive
	18	VTX_TX2N	O	1 st eDP-Phy data lane2 negative
	19	GND		GND
	20	VTX_TX1P	O	1 st eDP-Phy data lane1 positive
	21	VTX_TX1N	O	1 st eDP-Phy data lane1 negative
	22	GND		GND
	23	VTX_TX0P	O	1 st eDP-Phy data lane0 positive
	24	VTX_TX0N	O	1 st eDP-Phy data lane0 negative
	25	GND		GND
	26	VTX_PLL_LOCK	O	DP 2nd Hot Plug Detection
	27	VTX_HPDP	I	DP 1st Hot Plug Detection
	28	NC / GND		NC (default) / GND (assembly option)
	29	GPIO / NC	I/O	GPIO (default) Transistor switch / NC (assembly option)
	30	LD_EN	O	Local dimming enable (transistor switch)

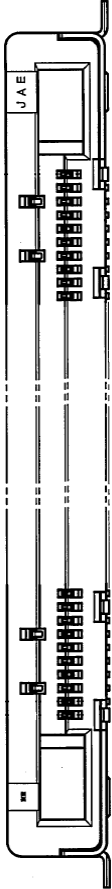
 <p>Side-View</p>	31	AUX_CH_P_2	I/O	2nd AUX channel positive
	32	AUX_CH_N_2	I/O	2nd AUX channel negative
	33	SCL	0	I2C serial clock
	34	SCA	I/O	I2C serial data
	35	AUX_CH_P_1	I/O	1st AUX channel positive
	36	AUX_CH_N_1	I/O	1st AUX channel negative
	37	LDC_ONOFF	0	LCD On/Off-signal
	38	GND / NC (option)		GND / NC (option)
	39	GND		GND
	40	GND		GND
	41	GND		GND
	42	GND		GND
	43	N.C.		
	44	+V_TCON	0	Panel Power (12V, 10V, 5V)
	45	+V_TCON	0	Panel Power (12V, 10V, 5V)
	46	+V_TCON	0	Panel Power (12V, 10V, 5V)
	47	+V_TCON	0	Panel Power (12V, 10V, 5V)
	48	+V_TCON	0	Panel Power (12V, 10V, 5V)
	49	+V_TCON	0	Panel Power (12V, 10V, 5V)
	50	+V_TCON	0	Panel Power (12V, 10V, 5V)
	51	+V_TCON	0	Panel Power (12V, 10V, 5V)

4.6.3 X13, LVDS-output (optional)

Type: DF20G-50DP-1 from Hirose (or equivalent)

Pin arrangement	Pin	Signal	I/O	Description
<p>Top-View</p> <p>Side-View</p>	1	LVDS_GPIO2	I/O	Digital in/out (3V3 or 0V)
	2	LVDS_GPIO1	I/O	Digital in/out (3V3 or 0V)
	3	LVDS.TXA0_N	0	TXA0 negative
	4	LVDS.TXB0_N	0	TXB0 negative
	5	LVDS.TXA0_P	0	TXA0 positive
	6	LVDS.TXB0_P	0	TXB0 positive
	7	GND		GND
	8	GND		GND
	9	LVDS.TXA1_N	0	TXA1 negative
	10	LVDS.TXB1_N	0	TXB1 negative
	11	LVDS.TXA1_P	0	TXA1 positive
	12	LVDS.TXB1_P	0	TXB1 positive
	13	GND		GND
	14	GND		GND
	15	LVDS.TXA2_N	0	TXA2 negative
	16	LVDS.TXB2_N	0	TXB2 negative
	17	LVDS.TXA2_P	0	TXA2 positive
	18	LVDS.TXB2_P	0	TXB2 positive
	19	GND		GND
	20	GND		GND
	21	LVDS.TXAC_N	0	TXA clock negative
	22	LVDS.TXBC_N	0	TXB clock negative
	23	LVDS.TXAC_P	0	TXA clock positive
	24	LVDS.TXBC_P	0	TXB clock positive
	25	GND		GND
	26	GND		GND
	27	LVDS.TXA3_N	0	TXA3 negative
	28	LVDS.TXB3_N	0	TXB3 negative
	29	LVDS.TXA3_P	0	TXA3 positive
	30	LVDS.TXB3_P	0	TXB3 positive
	31	GND		GND
	32	GND		GND
	33	LVDS.TXA4_N	0	TXA4 negative
	34	LVDS.TXB4_N	0	TXB4 negative
	35	LVDS.TXA4_P	0	TXA4 positive
	36	LVDS.TXB4_P	0	TXB4 positive
	37	LVDS_GPIO4	I/O	Digital in/out (3V3 or 0V)
	38	LVDS_GPIO5	I/O	Digital in/out (3V3 or 0V)
	39	LVDS_GPIO3	I/O	Digital in/out (3V3 or 0V)
	40	VTX_SDA	I/O	I2C-DATA (3V3-Level)
	41	+V_TCON*	0	Panel Power (12V, 10V, 5V)
	42	VTX_SCL	0	I2C-CLOCK (3V3-Level)
	43	+V_TCON*	0	Panel Power (12V, 10V, 5V)
	44	+V_TCON*	0	Panel Power (12V, 10V, 5V)
	45	+V_TCON*	0	Panel Power (12V, 10V, 5V)
	46	+V_TCON*	0	Panel Power (12V, 10V, 5V)
	47	+V_TCON*	0	Panel Power (12V, 10V, 5V)
	48	+V_TCON*	0	Panel Power (12V, 10V, 5V)
	49	+V_TCON*	0	Panel Power (12V, 10V, 5V)
	50	+V_TCON*	0	Panel Power (12V, 10V, 5V)

*: max 1A per pin @ AWG28 wire; 0.7A @ AWG32 wire

4.7. X14, Brightness Keys and external ON-Signal (optional)

Optional for ship display applications. Brightness Key 1/2 for external keys, ON-OFF-CTRL for switching off the display.

Type: JST-Ref.-No. B7B-EH

Pin arrangement	Pin	Signal	I/O	Description
	1	GND		GND
	2	+5V	P	+5V
	3	ON-OFF-CTRL	I	External ON / OFF CTRL
	4	Brightness Key1	I	Brightness Key1
	5	GND		GND
	6	Brightness Key2	I	Brightness Key2
	7	GND		GND

4.8. X15, uC CAN and LED-Control (optional)

This connector can be configured as CAN-interface or for driving external LEDs.

Type: JST-Ref.-No. B4B-EH

Pin arrangement	Pin	Signal	I/O	Description
	1	GND		GND
	2	+5V	P	+5V
	3	CAN RX	I	CAN RX / LED1-Out
	4	CAN TX	O	CAN TX/ LED2-Out

4.9. X16, Buzzer (optional)

Optional for ship display applications. Internal buzzer-signals are connected to microcontroller STM32F072.

Type: JST-Ref.-No. B4B-EH

Pin arrangement	Pin	Signal	I/O	Description
	1	GND		GND
	2	+5V	P	+5V
	3	BUZZER_POWER_OUT	O	+24V switched (max 100mA)
	4	BUZZER_PWM_OUT	O	PWM Out (+5V Level)

4.10. X17, USB Link-Select (optional)

Connector for USB-Link-Select Board.

Type: JST-Ref.-No. B4B-EH

Pin arrangement	Pin	Signal	I/O	Description
	1	GND		GND
	2	I2C-SCL	P	I2C-SCL (5V Level)
	3	I2C-SDA	O	I2C-SDA (5V Level)
	4	+5V	I/O	+5V
	5	USB-Link-Out	O	USB-Link-Out (+5V Level)
	6	USB-Link-IO	I/O	GPIO (+3V3 Level)

4.11. X18, STM32 Debug & ISP Header (optional)

Only for debugging and software update. Not assembled in MP.

Type: JST-Ref.-No. B6B-EH

Pin arrangement	Pin	Signal	I/O	Description
	1	+3V3	P	+3V3
	2	SWCLK	O	SWCLK (DEGUB) /GPIO
	3	GND	I/O	GND
	4	SWDIO	O	SWDIO (DEBUG) / GPIO
	5	RESET	I/O	uC Reset#
	6	NC		

4.12. X19, STM32 Boot Select Jumper (optional)

X19 is only for debugging and software development purposes, will not be assembled in MP.

4.13. X20, PWM Fan (option)

For connection of PWM-fan. (+12V, +24V optional)

Type: Molex 4pin 47053-1000 / 2,54mm (2170-0136-1041)

Pin arrangement	Pin	Signal	I/O	Description
	1	GND		GND
	2	+V_FanPower	Out	Fan Power (+12V / max 500mA)
	3	FAN_Tacho	In	Tacho signal
	4	FAN_PWM#	Out	PWM fan speed control

4.14. X21, System-Bus (I2C 3V3 Level)

Systembus (I2C/ 3V3 Level) for external components

Type: JST-Ref.-No. B4B-EH

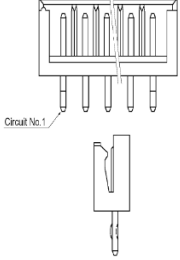
Pin arrangement	Pin	Signal	I/O	Description
	1	GND		GND
	2	I2C-SCL	P	I2C-SCL (3V3 Level)
	3	I2C-SDA	O	I2C-SDA (3V3 Level)
	4	+3V3	I/O	+3V3

4.15. X22, System-Bus (I2C 5V Level)

Systembus (I2C/ 5V Level) for external components

Type: JST-Ref.-No. B4B-EH

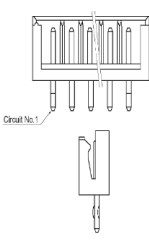
Pin arrangement	Pin	Signal	I/O	Description
	1	GND		GND
	2	I2C-SCL	P	I2C-SCL (5V Level)
	3	I2C-SDA	O	I2C-SDA (5V Level)
	4	+5V	I/O	+5V

4.16. X23, RS232 uC UART (optional)

RS232- interface for communication with uC

Type: JST-Ref.-No. B3B-EH

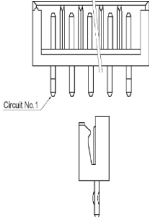
Pin arrangement	Pin	Signal	I/O	Description
	1	GND	P	GND
	2	TXD	O	Transmit Data
	3	RXD	I	Receive Data

4.17. X24, RS232 Scaler UART

RS232-interface for communication with Novatek scaler

Type: JST-Ref.-No. B3B-EH

Pin arrangement	Pin	Signal	I/O	Description
	1	GND	P	GND
	2	TXD	O	Transmit Data
	3	RXD	I	Receive Data

4.18. X25, USB Firmware update

Connector for update of firmware for Novatek-scaler. Update from USB-stick possible.

Type: USB type A receptacle, THT angled from TE Connectivity: 292303-1

Pin arrangement	Pin	Signal	I/O	Description
	1	VBUS	P	VBUS (+5V / 200mA)
	2	D-	IO	Data -
	3	D+	IO	Data +
	4	GND	IO	GND

4.19. X26, USB Communication (optional)

USB for communication with onboard μ C.

Type 53261-0471 by Molex, SMT Side entry type, 4pin, pitch 1.25mm

Pin arrangement	Pin	Signal	I/O	Description
<p>Top View</p>	1	ID	O	ID
	2	D-	IO	Data -
	3	D+	IO	Data +
	4	GND	O	GND

4.20. X27, TCON Voltage selection jumper (optional)

+V_TCON voltage can be selected by placing a jumper on X27.

Jumper on 1-2: +V_TCON = +12V

Jumper on 2-3: +V_TCON = +10V

No jumper: +V_TCON = +5V

Type: SL 11/124-03G by Fischer-Elektronik or equivalent

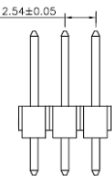
Pin arrangement	Pin	Signal	I/O	Description
	1	GND		GND
	2			
	3			

4.21. X28, Signal Routing for VBO / eDP output

As V-by-One- and eDP-signals for driving the TFT are both connected to X12 it is necessary to multiplex 2 signals depending on the type of signal.

The multiplexing of one signal is described in this chapter, the multiplexing of the other signal is described in the next chapter.

When a TFT with V-by-One input is connected to X12 the signal VTX.HPD should be connected to X12-27, when a TFT with eDP input is connected, the signal EDP-HPD0 should be connected to X12-27.

This multiplexing is realized by jumper connector X28.

For V-by-One signals place jumper on X28 2-3, for eDP signals place jumper on X28 1-2

Type: SL 11/124-03G by Fischer-Elektronik or equivalent

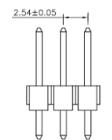
Pin arrangement	Pin	Signal	I/O	Description
	1	EDP_HPDP0_JP		1-2: for eDP signals
	2	X12-27		
	3	VTX_HPDP_JP		2-3: for VBO signals

4.22. X35, Signal Routing for VBO / eDP output

With X35 the second signal which is mentioned in the former chapter can be multiplexed.

When a TFT with V-by-One input is connected to X12 the signal VTX.PLLLOCK should be connected to X12-26, when a TFT with eDP input is connected, the signal EDP-HPD1 should be connected to X12-26.

This multiplexing is realized by jumper connector X35.

For V-by-One signals place jumper on X35 2-3, for eDP signals place jumper on X35 1-2

Type: SL 11/124-03G by Fischer-Elektronik or equivalent

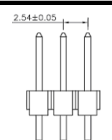
Pin arrangement	Pin	Signal	I/O	Description
	1	EDP_HPDP0_JP		1-2: for eDP signals
	2	X12-26		
	3	VTX_HPDP_JP		2-3: for VBO signals

4.23. X29, OSD-Keyboard-Connector

Type 53261-1271 by Molex, SMT Side entry type, 12pin, pitch 1.25mm

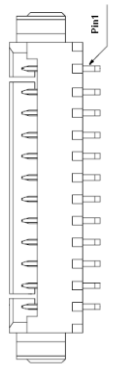
Connector	Pin	Signal-Name	I/O	Note
 <p>Top view</p>	1	LED1	O	LED Green
	2	LED2	O	LED RED
	3	IR	I	IR remote
	4	+5V	O	+5V
	5	GND		GND
	6	SW3	I	Button3 (UP / PLUS)
	7	SW2	I	Button2 (DOWN / MINUS)
	8	SW4	I	Button4 (SELECT / DOWN)
	9	SW6	I	Button6 (POWER)
	10	SW1	I	Button1 (MENU)
	11	SW5	I	Button5 (N.C. / UP)
	12	GND		GND

4.24. X30, Analog Audio Line-Out L/R

Audio Jack 3,5mm 3pin black

Type: CUI: SJ1-3535NG

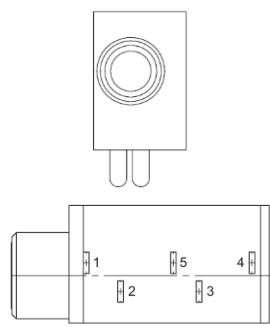
Pin arrangement	Pin	Signal	I/O	Description
	1	GND		GND
	2	LINE_OUT_L	O	Line out left
	3	LINE_OUT_R	O	Line out right
	4	NC		
	5	NC		

Pin assignment for mating connector:

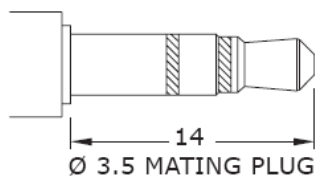

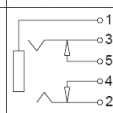
Model No.	SJ1-3535NG
Schematic	
PIN	
1	sleeve
2	tip
3	ring
4	tip switch
5	ring switch

4.25. X31, Digital Audio Out

Type: 53261-1471 by Molex, SMT Side entry type, 14pin, pitch 1.25mm

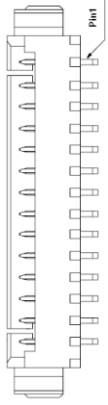
Pin arrangement	Pin	Signal	I/O	Description
 <p>Top view</p>	1	GND		GND
	2	5V		Power
	3	I2S_WS	0	I2S Word Select
	4	GND		GND
	5	I2S_Data	0	I2S Data
	6	GND		GND
	7	I2S_BCLK	0	I2S Clock
	8	GND		GND
	9	I2S_MCLK	0	I2S MCLK
	10	GND		GND
	11	MUTE	0	MUTE
	12	AUDIO_GPIO	I/O	GPIO
	13	I2C SDA	I/O	I2C SDA (3V3 level)
	14	I2C SCL	0	I2C SCL (3V3 level)

4.26. X32, Backlight-Dimming-Level select

The range of the analog dimming voltage and the signal high level of the digital PWM signal can be selected with the jumper on X32.

Jumper on X32	Range of signal ADIM (Analog Dimming) on X6-1, X7-1	High Level of signal PWM (Digital Dimming) on X6-2, X7-2
1-2	0V – 5.0V	High Level: 5.0V
2-3	0V – 3.3V	High Level: 3.3V

Type: SL 11/124-03G by Fischer-Elektronik or equivalent

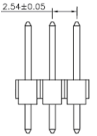
Pin arrangement	Pin	Signal	I/O	Description
	1	+5V		
	2	X32-2		
	3	+3V3_STBY		

4.27. X33, Backlight-Enable-Level Select

The level of the backlight-enable signal EN can be selected with the jumper on X33.

Jumper on X33	High Level of EN signal (X6-3, X7-3)
1-2	0V – 5.0V
2-3	0V – 3.3V

Type: SL 11/124-03G by Fischer-Elektronik or equivalent

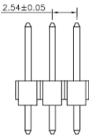
Pin arrangement	Pin	Signal	I/O	Description
	1	+5V		
	2	X33-2		
	3	+3V3_STBY		

4.28. X34, Backlight-Enable-Polarity Select

The polarity of the signal EN (for backlight enabling) can be set to active high or active low with the jumper on X34.

Jumper on X34	Polarity of EN-Signal
1-2	High Active
2-3	Low Active

Type: SL 11/124-03G by Fischer-Elektronik or equivalent

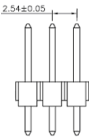
Pin arrangement	Pin	Signal	I/O	Description
	1	EN		
	2			
	3			

4.29. X42, TCON power

TCON supply voltage for high current TCON boards: In addition to pins 44 – 50 of X12, this connector can be used to drive high current TCON board or TCON boards which have a separate power supply input connector.

(These TCON board have normally a TCON voltage of +12V, so this voltage is mentioned below)

Type: JST-Ref.-No. B6B-EH

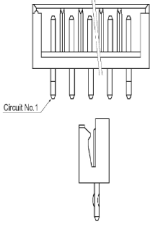
Pin arrangement	Pin	Signal	I/O	Description
	1	GND		GND
	2	GND		GND
	3	GND		GND
	4	+V_TCON		TCON Power (+5V/ +10V/ +12V)*
	5	+V_TCON		TCON Power (+5V/ +10V/ +12V)*
	6	+V_TCON		TCON Power (+5V/ +10V/ +12V)*

* maximum 6A in total for all pins is available. Voltage can be adjusted by jumper on X27 or by firmware.

5. Technical Details

5.1. Block Diagram

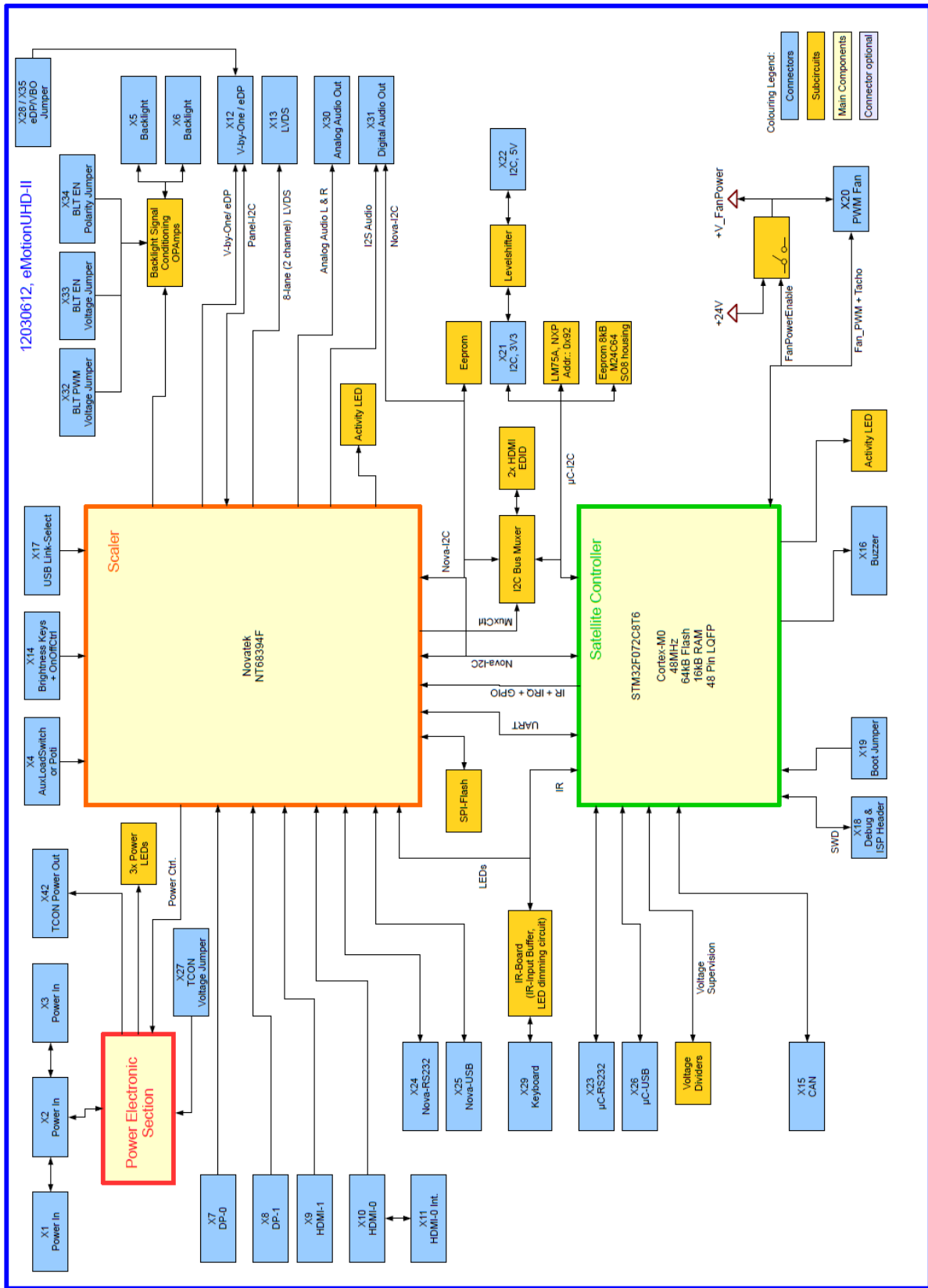

Design with Novatek NT68394G

5.2. Supply Voltages and Current Consumption

The eMotionUHD-II is developed for 24V DC input voltage. The backlight supply voltage is always equivalent to the DC input voltage of the eMotionUHD-II. The board is designed for a single power supply. All other supply voltages are generated on the eMotionUHD-II.

Note: The backlight inverter must fit to the input voltage, if it is not a separate board/circuit is necessary.

Board	Supply voltage	Regulation	Ripple & noise	Onboard current consumption	
				Operating*	Stand-By / Power-Off
12030612	+24V	+/-10%	0.3V	250mA max.	25mA max.
12032701	+24V	+/-10%	0.3V	220mA max.	15mA max.

*: no input signal connected

5.3. TCON Voltage

TCON voltage is selectable by firmware or by using jumper on X7 when firmware feature is disabled. 3 different voltages are selectable. Max current for the TCON is 6A.

TCON Voltage	Nominal value	Max Current	Ripple & noise	Comment
+12V	12V	6A	0.1V	Jumper on X27: 1-2
+10V	10V	6A	0.1V	Jumper on X27: 2-3
+5V	5V	6A	0.1V	No jumper on X27

5.4. Input and Output Signals

5.4.1 DP Input

According to DisplayPort V1.2a. (4Kx2K@60),

DP input supports:

- RBR/HBR/HBR2 with 1,2 or 4 lanes
- AUX CH 1 Mbps
- HDCP 1.4 (Compliance V1.2) and HDCP 2.2
- HPD out

5.4.2 HDMI Input

PARAMETER	MIN	TYP	MAX	UNIT	Remark
Termination Supply Voltage AV _{CC}	3,135	3.3	3,465	V	
Differential Input Voltage	150		1200	mV	
Input Common Mode Voltage	AV _{CC} -300		AV _{CC} -37	mV	
Input Clock frequency	20		165	MHz	

5.4.3 Vx1 Output

- Support 8 lane Vx1 (Vx1_TX0~Vx1_TX7) output for UHD displays
- Support 3/4 byte mode, support 24/30bit, RGB444
- Vx1 output max. transmission rate 3.7Gbps, min. is 1.2Gbps
- Support SSC for reduce EMI

5.4.4 eDP Output

- Support 2 eDP V1.4 phy and 2 eDP V1.4 link
- Every eDP phy/link supports 1,2 or 4 lanes
- Full link training and fast link training, link rate RBR, HBR, HBR2
- AUX CH 1 Mbps; SSC for reduce EMI

6. Optional Features for Ship Displays

Optional features for ship display applications are available for eMotionUHD-II. Some of that features can be realized with a special firmware for the scaler IC and for some features a separate microcontroller is implemented on eMotionUHD-II.

The variant with a separate microcontroller has the ERP # 12030612 (see chapter 2.2).

Following features for ship display applications are available for the eMotionUHD-II.

6.1. Fan Speed Control

On X20 a PWM fan can be connected. The microcontroller measures the temperature from the onboard temperature sensor and regulates the fan speed.

6.2. External Brightness Key

The feature “External Brightness Keys“ is realized by the connector pins X14-4 and X14-6. The functionality is implemented in the firmware of the scaler IC NT68394.

6.3. External Brightness Poti

On X4-2 or X4-3 analog voltages can be generated by an external connected potentiometer. The microcontroller can evaluate the voltage level and control the backlight brightness according to that value.

6.4. External ON/OFF Signal

The feature “External ON/OFF Signal“ is realized by the connector pin X14-3. The functionality is implemented in the firmware of the scaler IC NT68394.

6.5. Internal Buzzer

The feature “Internal Buzzer“ is realized by the connector X16. The signals on this connector are destined to drive a 24V-buzzer. The buzzer is switched on by X16-3 (BUZZER_POWER_OUT). Additionally, there is a 5V-level PWM-output signal on X16-4. The functionality is implemented in the firmware of the microcontroller.

6.6. External Buzzer

The feature “External Buzzer“ is realized by the connector X4. An external buzzer can be detected and enabled when it is connected to X4. The functionality is implemented in the firmware of the microcontroller.

6.7. USB-Link-Select

The feature “USB-Link-Select“ is realized by the connector pin X17. The functionality is implemented in the firmware of the scaler IC NT68394.

6.8. Data Modul Backlight Inverter

DATA MODUL has developed a wide range LED backlight inverter. This inverter is controlled by I²C-bus which is connected to X17. This functionality is implemented in the firmware of the scaler IC NT68394.

6.9. ALC Sensor

An ambient light sensor can be connected to X21 or X22 (I²C-bus with 3V3- or 5V-level). Based on the measurements the backlight brightness can be controlled. This functionality is implemented in the firmware of the scaler IC NT68394.

6.10. RS232

The RS232-interface for the microcontroller is implemented on X23, the RS232-interface of the scaler IC is implemented on X24. Protocol for microcontroller is t.b.d.

7 Qualification

7.1 Environmental conditions

Parameter	Min	Max
Operating temperature	0°C	+60°C
Storage temperature	-20°C	+80°C
Relative humidity	TBD	80%
Tolerable air-pressure		708 hPa (approx. Altitude 3000m)

7.2 EMI-Standards

7.2.1 EMC/EMI-Standards

Designed to meet EMC (Electro-Magnetic Compatibility): Immunity for industrial environments, according to EN 61000-6-2:

Description	Requirements	Test parameter	Criteria
Electrostatic discharge immunity test	EN 61000-4-2	±4kV contact discharge, ±8kV air discharge	criteria B
Radiated, radio frequency, electromagnetic field immunity test	EN 61000-4-3	80-1000MHz 10V/m, 1,4-2GHz 3V/m 2-2,7GHz 1V/m 80% AM (1kHz)	criteria A
Electrical fast transient/burst immunity test	EN 61000-4-4	±1kV on I/O lines	criteria B
Immunity to conducted disturbance, induced by radio-frequency fields	EN 61000-4-6	0,15 – 80 MHz 10V _{rms} 80% AM (1kHz)	criteria A

Note: To ensure that the board meets the standard mentioned above, an adequate shielding cover must be added. Alternatively the housing of the monitor must act as shielding cover (e.g. aluminium enclosure).

7.3 Safety

- Designed to meet: IEC 62368-1
- Designed to meet UL 62368-1
- PCB is manufactured to meet UL94V-0 and 130°C operating temperature max. UL-sign and E-file-no. are visible on PCB, see chapter 9.2

7.4 Shock and Vibration

MECHANICAL STRESS

Shock:	20G, 11ms, half sine (x/y direction)
	15G, 11ms, half sine (z direction)
Vibration:	1.2G, 10 – 55Hz, sinus
Sweep:	1 minute/octave
Amplitude:	0.35mmp-p (x-direction)
	0.35mmp-p (y direction)
	0.175mmp-p (z-direction)
Time :	30 minutes
Standard:	Conform to EN60605

7.5 Reliability, MTBF

- min. 500.000h at Ta = 40°C, determined according to Telcordia SR-332

8 Warranty, Quality and Environmentalism

8.1 Warranty

- Manufacturer warranty: 12 months after delivery

8.2 Quality

The producing process of the board is aligned with the guideline according to the DIN ISO 9001 certification.

Workmanship standard: IPC-A-610F Class2

8.3 Environmentalism

The list of used materials is based on the parts list, which is available at DATA MODUL ERP-system

The PCB is produced under lead free soldering conditions.

All components are produced according to European RoHS (RoHS-1 = 2002/95/EU, RoHS-2 = 2011/65/EU) and REACH (2006/1907/EU) regulations. The board is designed and manufactured to meet ISO 14001.

The packing complies to directive 1994/62/EU.

9 Label and PCB markings

9.1 Label and Material Number

The following points are visible on the label of the eMotionUHD-II board.

- Material number
- Serial- and Revision-number
- Manufacturing date

9.2 Marking of PCB

The following points are visible on the PCB of the eMotionUHD-II board.

- DATA MODUL Logo
- UL-Sign on PCB
- E-File-No. of PCB manufacturer

DATA MODUL Aktiengesellschaft

Landsberger Str. 322
80687 Munich, Germany
Tel. +49-89-5 60 17-0
Fax +49-89-5 60 17-119
www.data-modul.com

Logistics, Production & Services:

DATA MODUL Weikersheim GmbH
Lindenstrasse 8
DE-97990 Weikersheim - Germany
Phone: +49-7934-101-0
Fax: +49-7934-101-101

DATA MODUL's worldwide offices

can be found on our website:
www.data-modul.com/eu/contact-worldwide.html

