



SPECIFICATION

easy // TOUCH
DISPLAY

eTD070W2105-POA-E (12039377)

7.0" - WVGA - COF

Version: 1.3

Date: 20.01.2020

Note: This specification is subject to change without prior notice

www.data-modul.com

Contents

1. SPECIFICATIONS	3
1.1 Features	3
1.2 Mechanical Specifications	3
1.3 Absolute Maximum Ratings	4
1.4 DC Electrical Characteristics	4
1.5 Optical Characteristics	5
1.6 Backlight Characteristics	8
1.7 Touch Panel Characteristics	9
1.8 Touch Performance	9
2. MODULE STRUCTURE	10
2.1 Counter Drawing	10
2.1.1 LCM Mechanical Diagram	10
2.1.2 Block Diagram	10
2.2 Interface Pin Description	11
2.3 Touch Panel Description	13
2.3.1 Block Diagram	13
2.3.2 I2C Operation	13
2.3.3 USB Operation	14
2.4 TFT LCM Timing Characteristics	14
3. QUALITY ASSURANCE SYSTEM	18
3.1 Quality Assurance Flow Chart	18
3.2 Inspection Specification	20
4. RELIABILITY TEST	27
4.1 Reliability Test Condition	27
5. PRECAUTION RELATING PRODUCT HANDLING	28
5.1 SAFETY	28
5.2 HANDLING	28
5.3 STORAGE	28
5.4 TERMS OF WARRANTY	28

1. SPECIFICATIONS

1.1 Features

Item	Standard Value
Display Resolution	800 * 3 (RGB) * 480 Dots
LCD Type	a-Si TFT , Normally white, Transmissive type
Screen size(inch)	7.0 inch
Viewing Direction	6 O'clock (Gray scale Inversion)*1
	12 O'clock (*2)
Surface treatment	Anti-Glare (LCD)
	Clear(T/P)
Color configuration	RGB Vertical Strip
Backlight Type	White LED B/L
Weight	191g
Interface	24 Bits RGB interface
ROHS	THIS PRODUCT CONFORMS THE ROHS OF PTC Detail information please refer website : http://www.powertip.com.tw/news_detail.php?Key=1&cID=1

Note:

*1. For saturated color display content (eg. pure-red, pure-green, pure-blue or pure-colors - combinations).

*2. "For display content based upon multicolor images eg. photos, RGB defined user interfaces"

1.2 Mechanical Specifications

Item	Standard Value	Unit
Outline Dimension	182.74(W) * 114.58 (L) *5.37 (H)	mm

LCD panel

Item	Standard Value	Unit
Active Area	154.08 (W) * 85.92 (L)	mm

Note: For detailed information, please refer to LCM drawing.

1.3 Absolute Maximum Ratings

Module

Item	Symbol	Condition	Min.	Max.	Unit
Power Supply for TFT Panel	VDD	GND=0V	-0.3	+5.0	V
Power Supply for Backlight Unit	VCC	GND=0V	-0.3	+20.0	V
Operating Temperature	T _{OP}	-	-20	+70	°C
Storage Temperature	T _{ST}	-	-30	+80	°C

The absolute maximum rating values of this product are not allowed to be exceeded at any times. Should a module be used with any of the absolute maximum ratings exceeded, the characteristics of the module may not be recovered, or in an extreme case, the module may be permanently destroyed.

1.4 DC Electrical Characteristics

Module

GND = 0V, Ta = 25°C

Item	Symbol	Condition	Min.	Typ.	Max.	Unit
Power Supply for Backlight Unit	VCC	GND=0V	5	12	18	V
Input Voltage for TFT Panel	V _{IH}	GND=0V	0.7VDD	-	VDD	V
	V _{IL}	GND=0V	0	-	0.3VDD	V
Supply Current for TFT Panel	IDD	IDD@VDD=3.3V	-	110	165	mA
Supply Current for Backlight Unit	ICC	ICC@VCC=5V	-	650	780	mA
Input Voltage for PWM Signal	VPH	GND=0V	1.2	-	-	V
	VPL	GND=0V	-	-	0.4	V
Dimming Clock Rate	fP	GND=0V	5	-	100	KHz

1.5 Optical Characteristics

TFT LCD Module

VDD = 3.3 V, Ta=25°C

Item	Symbol	Condition	Min.	Typ.	Max.	unit	
Response time	Tr+Tf	-	-	25	38	ms	
Viewing angle	Top	$\theta Y+$	CR \geq 10	-	60	-	Deg.
	Bottom	$\theta Y-$		-	60	-	
	Left	$\theta X-$		-	60	-	
	Right	$\theta X+$		-	60	-	
Contrast ratio	CR	-	500	600	-		
Color of CIE Coordinate (With B/L)	White	X	IF=140mA	0.25	0.30	0.35	-
		Y		0.27	0.32	0.37	
	Red	X		0.52	0.57	0.62	
		Y		0.28	0.33	0.38	
	Green	X		0.29	0.34	0.39	
		Y		0.55	0.60	0.65	
	Blue	X		0.10	0.15	0.20	
		Y		0.02	0.07	0.12	
Average Brightness Pattern=white display (With B/L)*1	IV	IF=140mA	680	850	-	cd/m ²	
Uniformity (With B/L)*2	ΔB	-	70	-	-	%	

Note 1:

*1 : $\Delta B = B(\text{min}) / B(\text{max}) * 100\%$

*2 : Measurement Condition for Optical Characteristics:

a : Environment: $25 \pm 5^\circ \text{C} / 60 \pm 20\% \text{R.H}$ · no wind · dark room below 10 Lux at typical lamp current and typical operating frequency.

B : Measurement Distance: $500 \pm 50 \text{ mm}$ · ($\theta = 0^\circ$)

c : Equipment: TOPCON BM-7 fast · (field 1°) · after 10 minutes operation.

D : The uncertainty of the C.I.E coordinate measurement ± 0.01 · Average Brightness $\pm 4\%$

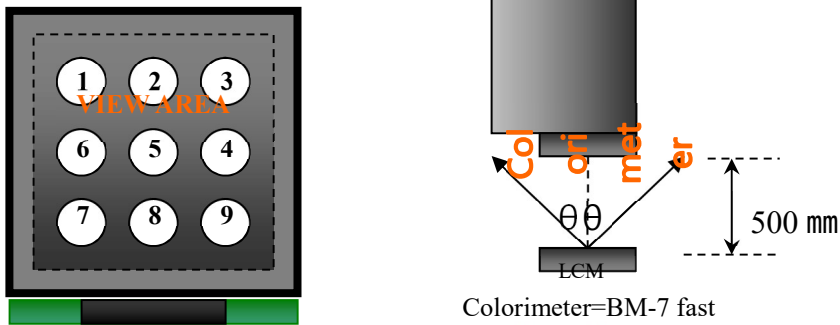

To be measured at the center area of panel with a viewing cone of 1° by Topcon luminance meter BM-7, after 10 minutes operation (module)

Note2: Definition of response time:

The output signals of photo detector are measured when the input signals are changed from "black" to "white"(falling time) and from "white" to "black"(rising time), respectively. The response time is defined as the time interval between the 10% and 90% of Amplitudes.

Refer to figure as below:
Normally White

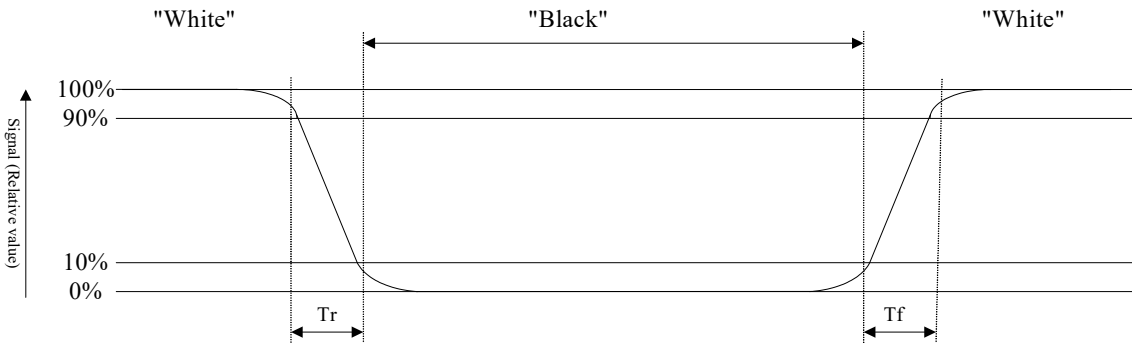

Normally Black

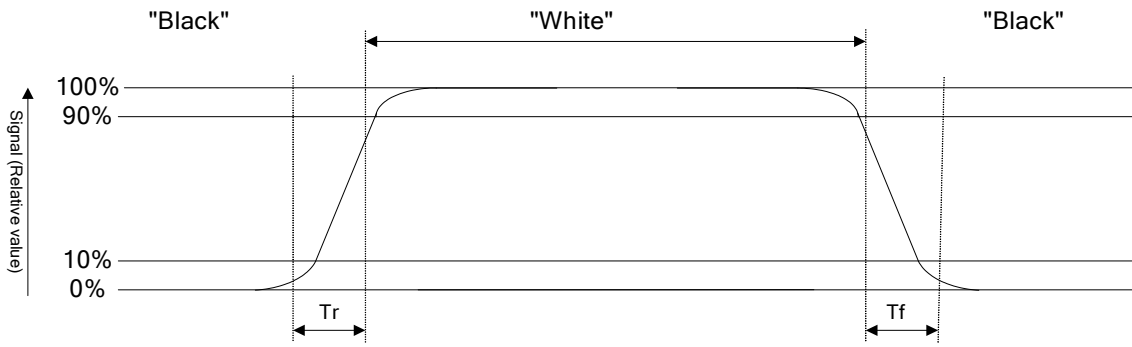

Note3: Definition of contrast ratio:

Contrast ratio is calculated with the following formula

$$\text{Contrast ratio (CR)} = \frac{\text{Photo detector output when LCD is at "White" state}}{\text{Photo detector output when LCD is at "Black" state}}$$

Note4: Definition of viewing angle:

Refer to figure as below:

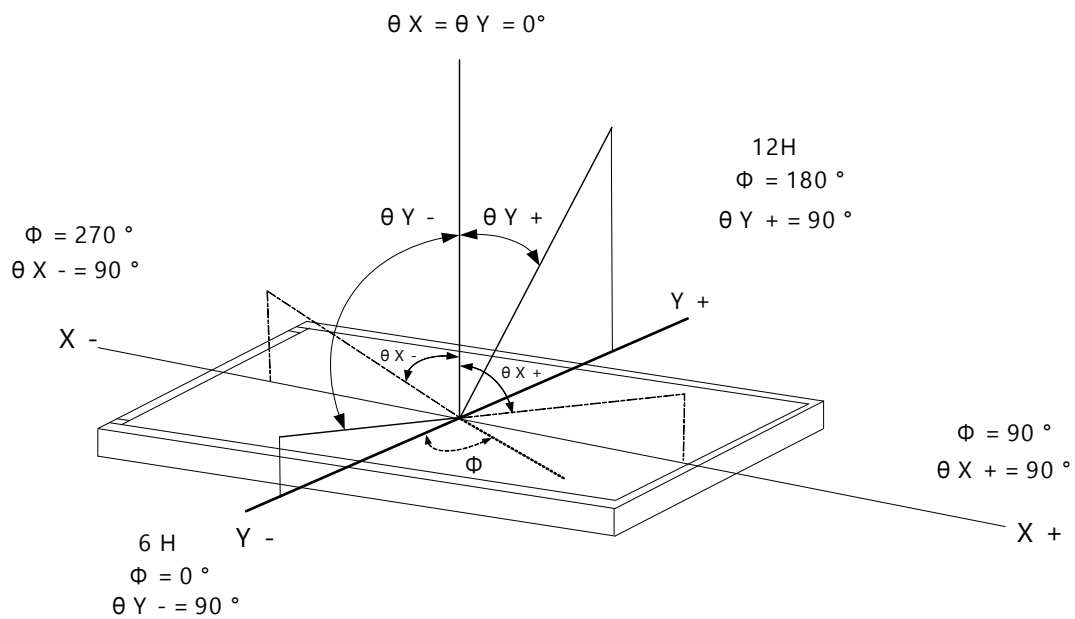

1.6 Backlight Characteristics

Maximum Ratings

Item	Symbol	Min.	Max.	Unit	Remark
LED Forward Current	I_F		35	mA	One LED
LED Reverse Voltage	V_R		10	V	

Electrical / Optical Characteristics

Item	Symbol	Min.	Typ.	Max.	Unit	Remark
LED Voltage	V_L	14.7	18.0	19.2	V	Note1
LED Current	I_L	-	140	-	mA	-
LED life time	-	50000	-	-	Hr	Note2

Note 1: The LED Supply Voltage is defined by the number of LED at $T_a=25\text{ }^\circ\text{C}$ and $I_L=140\text{ mA}$.

Note 2: The "LED life time" is defined as the module brightness decrease to 50% original brightness at $T_a=25\text{ }^\circ\text{C}$ and $I_L=140\text{ mA}$. The LED life time could be decreased if operating I_L is larger than 140mA.

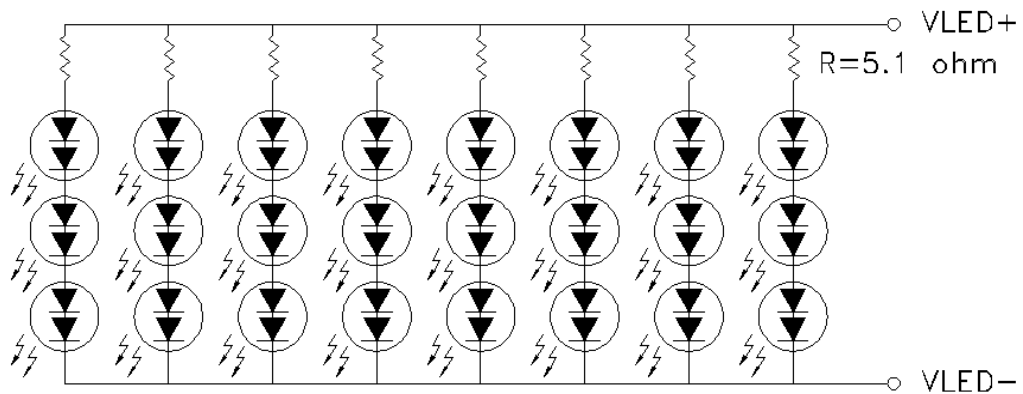

1.7 Touch Panel Characteristics Features

Item	Standard Value
Touch Panel Size	7"
Touch type	Projective Capacitive Touch Panel
Input Method	Finger / 10 Points touch
Output Interface	I ² C / USB
IC	ILI2511
I ² C Address	0x41(7bit)

Mechanical Specifications

Item	Standard Value	Unit
Viewing Area	154.88 (W) * 86.72 (L)	mm
Number of sensing channel	30(RX)*17(TX)	

Absolute Maximum Ratings

Item	Symbol	Condition	Min.	Max.	Unit
Supply voltage	TPVDD	Ta = 25°C	-0.3	+6.0	V
Operating Temperature	T _{OP}	Ta = 25°C	-10	+60	°C
Storage Temperature	T _{ST}	Ta = 25°C	-20	+70	°C

DC Electrical Characteristics

Item	Symbol	Condition	Min.	Typ.	Max.	Unit
Power Supply Voltage	TPVDD	Ta = 25°C	3.5		6.0	V

1.8 Touch Performance

This touch device offers operation with 10 fingers simultaneously. It is intended for indoor use in industrial applications.

This module is designed to have single touch functionality when operating with freshwater. It is not designed to have functionality when operating with saltwater. Ghost touches may occur and operation might not be possible.

The module is designed to have limited functionality when operating with thin gloves.

2. MODULE STRUCTURE

2.1 Counter Drawing

2.1.1 LCM Mechanical Diagram

* See Appendix

2.1.2 Block Diagram

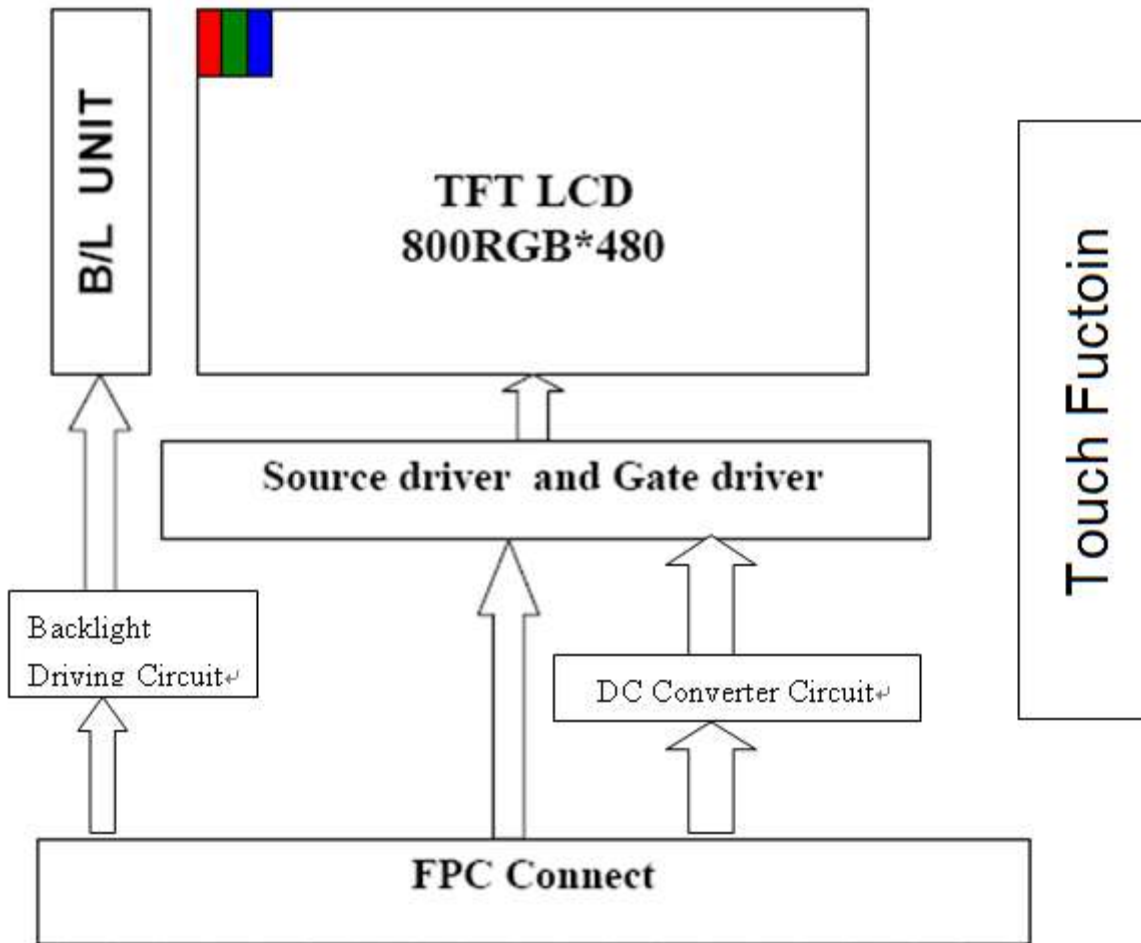

2.2 Interface Pin Description

TFT LCM Interface

Pin #	Name	DESCRIPTION
1	GND	Power Ground.
2	VDD	Power for Digital Circuit.
3	VDD	Power for Digital Circuit.
4	VCC	Power For LED backlight.
5	VCC	Power For LED backlight.
6	PWM	Shutdown & Dimming control input for backlight. Do not allow this pin to float. "Hi" =100%, "Low" = 0%.
7	GND	Power Ground.
8	R0	Red Data.
9	R1	Red Data.
10	R2	Red Data.
11	R3	Red Data.
12	GND	Power Ground.
13	R4	Red Data.
14	R5	Red Data.
15	R6	Red Data.
16	R7	Red Data.
17	GND	Power Ground.
18	G0	Green Data.
19	G1	Green Data.
20	G2	Green Data.
21	G3	Green Data.
22	GND	Power Ground.
23	G4	Green Data.
24	G5	Green Data.
25	G6	Green Data.
26	G7	Green Data.
27	GND	Power Ground.
28	B0	Blue Data.
29	B1	Blue Data.

Pin	Name	DESCRIPTION
30	B2	Blue Data.
31	B3	Blue Data.
32	GND	Power Ground.
33	B4	Blue Data.
34	B5	Blue Data.
35	B6	Blue Data.
36	B7	Blue Data.
37	GND	Power Ground.
38	HS	Line synchronization signal. Horizontal Sync Input.
39	VS	Frame synchronization signal. Vertical Sync Input.
40	GND	Power Ground.
41	DE	Display enable pin from controller. Data Input Enable.
42	GND	Power Ground.
43	DCLK	Sample clock. Data will be latched at the falling edge of DCLK.
44	GND	Power Ground.
45	CS(NC) / ID1	No Function./ ID[4:1]These pins select LCM type.
46	SDIN(NC) / ID2	No Function./ ID[4:1]These pins select LCM type.
47	SCK(NC) / ID3	No Function . / ID[4:1]These pins select LCM type.
48	DISPLAY CONTROL / ID4	Display Enable(Hi Active)./ ID[4:1]These pins select LCM type.
49	/RESET	Global Reset(Low Active).
50	GND	Power Ground.

Capacitive Touch Panel (CTP) Interface

Pin	Name	DESCRIPTION
1	TPVDD	Power supply for touch panel
2	I2C_CHG	Interrupt
3	I2C_SDA	Serial data line
4	I2C_SCL	Serial clock line
5	Reset	Reset
6	USB_D_N	D-
7	USB_D_P	D+
8	NC	NC
9	NC	NC
10	GND	GND

2.3 Touch Panel Description

The touch panel can be operated either via I2C or via USB. A list of supported operating system is given in the following table. For drivers listed in the table, please contact your regional Data Modul sales contact.

A recommended connector for the touch tail is OMRON XF2M-1015-1A.

For easy design-in, Data Modul can provide additionally an adaptor for I2C and USB connection (incl. corresponding USB cable). Please contact your regional Data Modul sales contact for further details.

System	Interface	Function	Driver Version	Document
Windows 10 Windows 8 Embedded 8.1 Industry Embedded 8.1 Pro Embedded 8 Standard	USB	Multi Touch	Windows In-Box Driver	N/A
Windows 7 Windows Embedded 7 Embedded Enterprise 7 Embedded Standard 7 Embedded POSReady7	USB	Multi Touch	Windows In-Box Driver	N/A
Linux 2.6.36 Upward	USB	Multi Touch	Linux In-Box Driver	N/A
Linux 2.6.36 Upward	I2C	Multi Touch	ilitek_limv5_7_0_0	ILITEK_LINUX_I2C_DRIVER_CHS_V0.0.6
RTOS	I2C	Depends on system	NA	Please contact your Data Modul Sales Representative I

2.3.1 Block Diagram

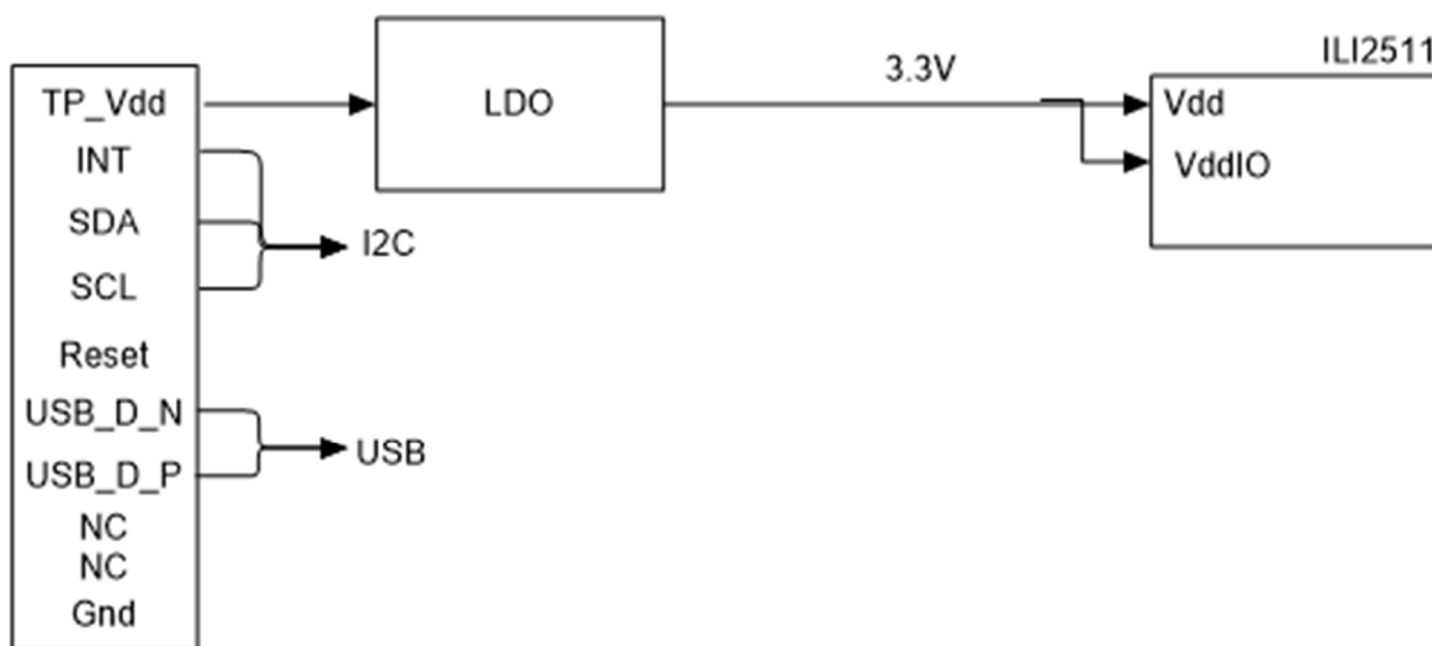

2.3.2 I2C Operation

TP_VDD, I2C_CHG, I2C_SDA, I2C_SCL and RESET lines are needed for I2C operation. External pull up resistors on SDA and SCL lines are required (recommendation 4.7kΩ). On INT as well as Reset line, there is no additional pull up resistors required. Please note that VddIO voltage is always 3.3V since this voltage is derived from the LDO on the flex tail.

For detailed documentation on the software integration of I2C, please contact your regional Data Modul sales contact.

2.3.3 USB Operation

TP_VDD, USB_D_N and USB_D_P are needed for USB operation. The TP will work with most Windows version out of the box using built-in drivers (HIDUSB driver) as well as with Linux. Please note that Data Module offers the easyAnalyzer, a visualization and evaluation software, for Windows as well as x86 Linux systems. Please contact your regional Data Modul sales contact for further details.

2.4 TFT LCM Timing Characteristics

2.4.1 Signal AC Characteristics

DE Mode (MODE='1')

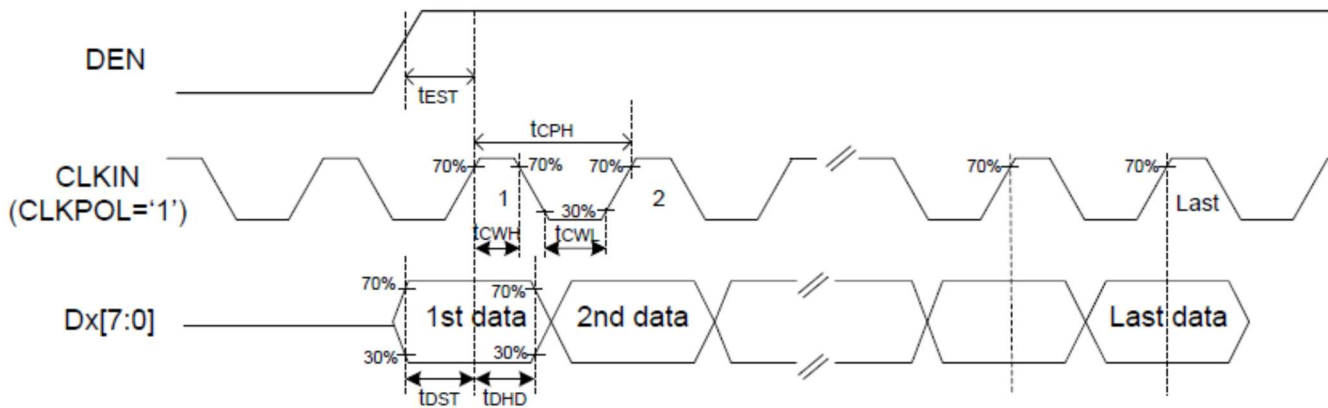

SYNC Mode (MODE='0')

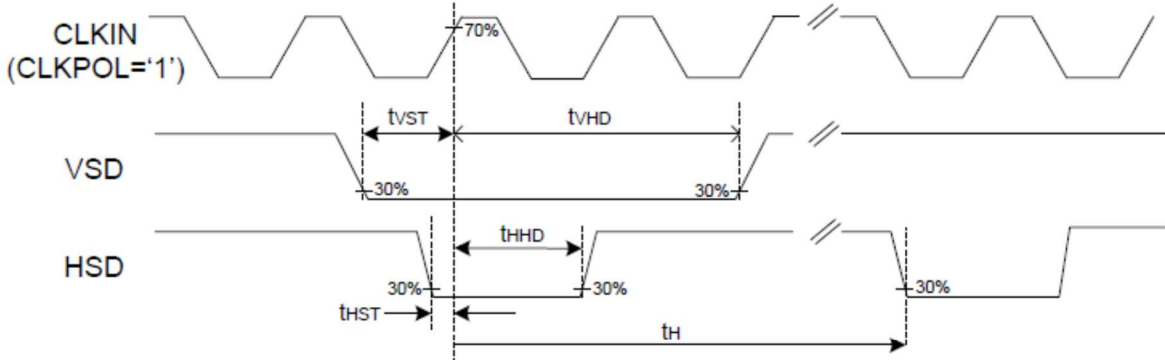

Source Output timing Diagram (Cascade)

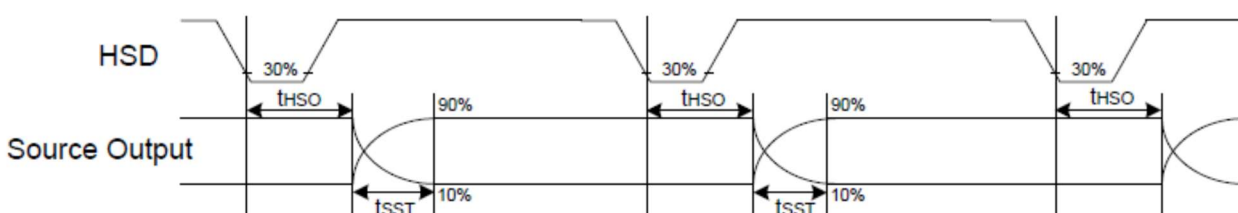

Vertical Timing Diagram of SYNC Mode (Dual Gate)

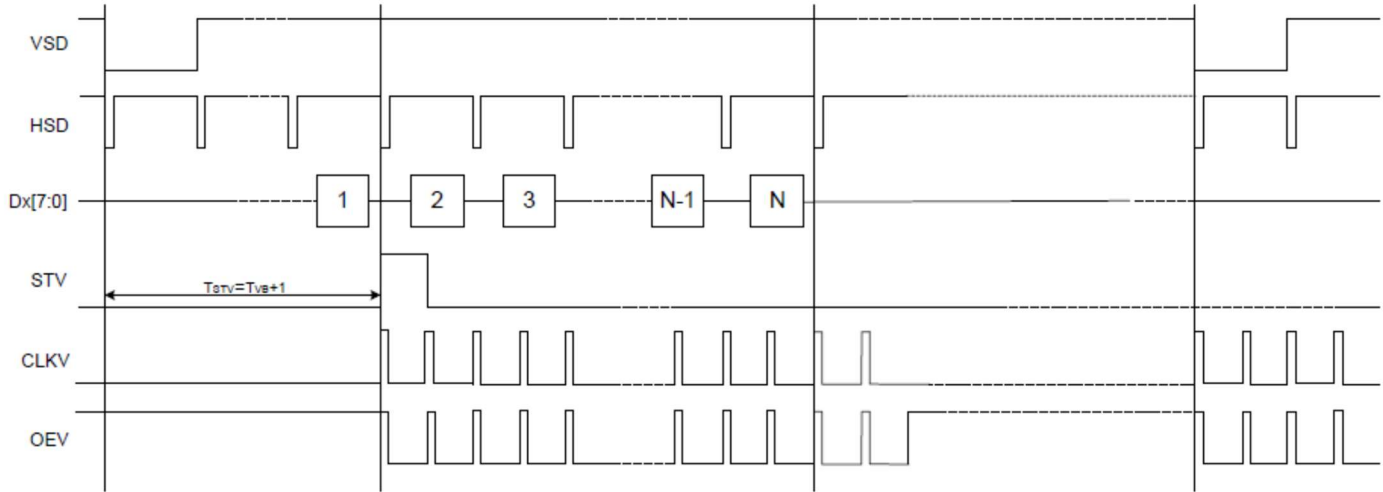

Vertical Timing Diagram of DE Mode (Dual Gate)

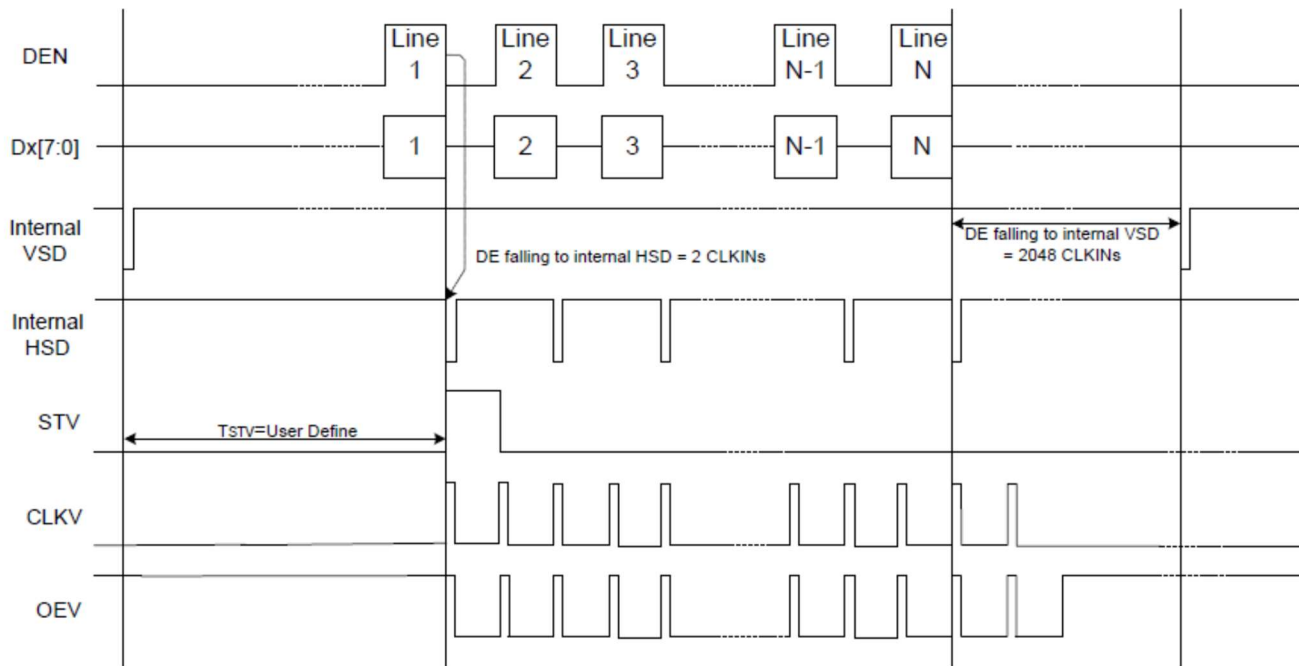

Gate Output Timing Diagram (Dual Gate)

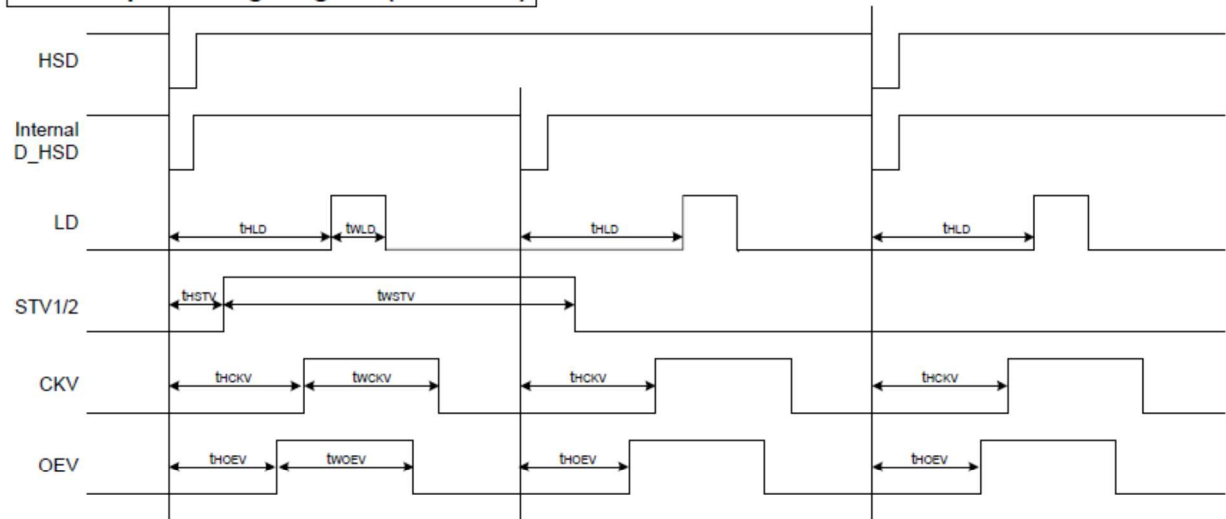

Parameter	Symbol	Spec			Unit	Conditions
		Min.	Typ.	Max.		
VDD Power ON slew rate	t_{POR}	--	--	20	ms	0V ~ 0.9VDD
RSTB pulse width	t_{RST}	10	--	--	us	CLKIN=50MHz
CLKIN cycle time	t_{CPH}	20	--	--	ns	
CLKIN pulse duty	t_{CWH}	40	50	60	%	
VSD setup time	t_{VST}	8	--	--	ns	
VSD hold time	t_{VHD}	8	--	--	ns	
HSD setup time	t_{HST}	8	--	--	ns	
HSD hold time	t_{HHD}	8	--	--	ns	
Data setup time	t_{DST}	8	--	--	ns	D0[7:0], D1[7:0], D2[7:0] to CLKIN
Data hold time	t_{DHD}	8	--	--	ns	D0[7:0], D1[7:0], D2[7:0] to CLKIN
DE setup time	t_{EST}	8	--	--	ns	
DE hold time	t_{EHD}	8	--	--	ns	
Output stable time	t_{SST}	--	--	6	us	10% to 90% target voltage. CL=120pF, R=10KΩ
CLKIN frequency	f_{CLK}	--	40	50	MHz	VDD=3.0 ~ 3.6V
CLKIN cycle time	t_{CLK}	20	25	--	ns	
CLKIN pulse duty	t_{CWH}	40	50	60	%	T_{CLK}
Time from HSD to Source output	t_{HSO}	--	20	--	CLKIN	
Time from HSD to LD	t_{HLD}	--	20	--	CLKIN	Note (2)
Time from HSD to STV	t_{HSTV}	--	2	--	CLKIN	
Time from HSD to CKV	t_{HCKV}	--	20	--	CLKIN	
Time from HSD to OEV	t_{HOEV}	--	4	--	CLKIN	
LD pulse width	t_{WLD}	--	10	--	CLKIN	Note (2)
CKV pulse width	t_{WCKV}	--	66	--	CLKIN	
OEV pulse width	t_{WOEV}	--	74	--	CLKIN	

Note: (1) VDD=3.0 ~ 3.6V, VDDA=6.5~13.5V, DGND=AGND=0V, Ta=-20~+85 °C

(2) The contents of the data register are transferred to the latch circuit at the rising edge of LD. Then the gray scale voltage is output from the device at the falling edge of LD.

(3) Output loading condition :

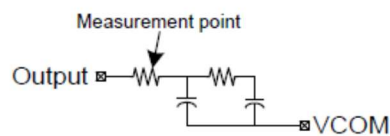

2.4.2 Input Timing Setting

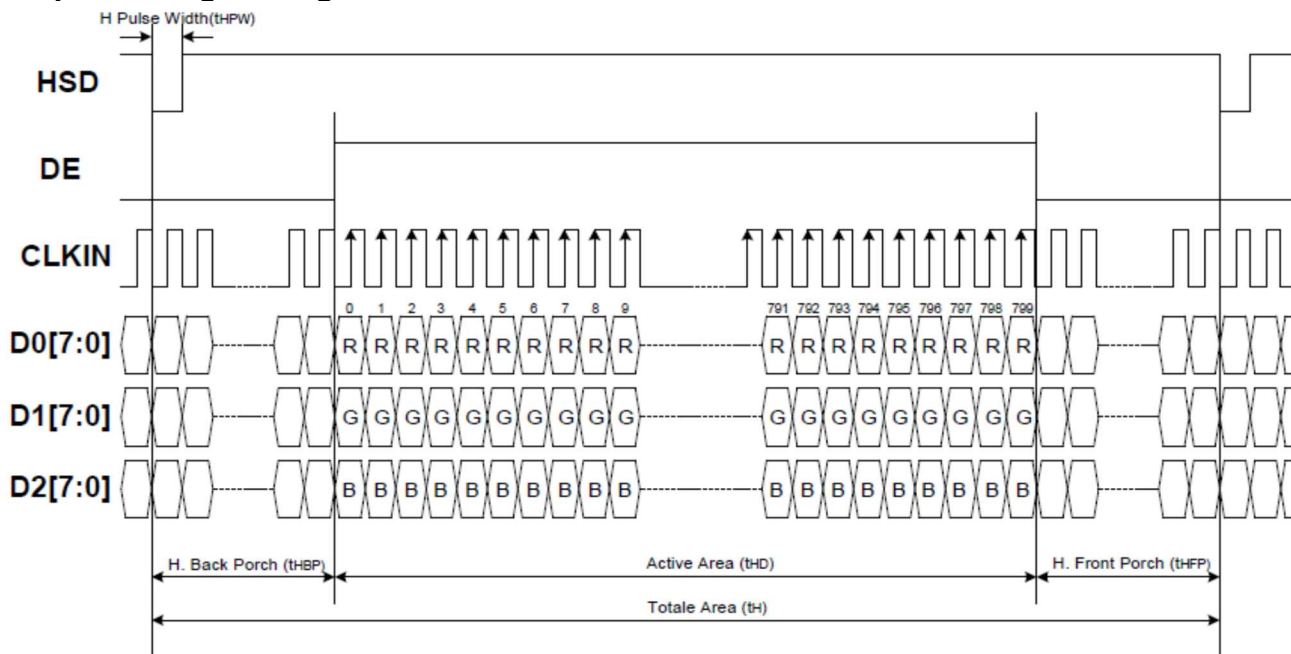

Horizontal Input Timing						
Parameter	Symbol	Value			Unit	
		Min.	Typ.	Max.		
Horizontal display area	t _{HD}	--	800	--	CLKIN	
CLKIN frequency	f _{CLK}	--	33.3	50	MHz	
1 Horizontal line period	t _H	862	1056	1200	CLKIN	
HSD pulse width	Min.	--	1	--	CLKIN	
	Typ.	--	--	--	CLKIN	
	Max.	--	40	--	CLKIN	
HSD back porch	SYNC	t _{HBP}	46	46	CLKIN	
HSD front porch	SYNC	t _{HFP}	16	210	354	CLKIN

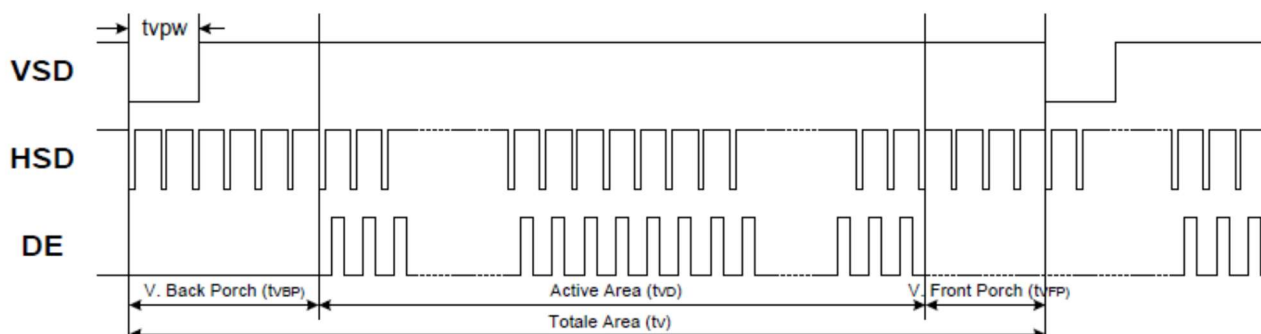

Vertical Input Timing					
Parameter	Symbol	Value			Unit
		Min.	Typ.	Max.	
Vertical display area	t _{VD}	--	480	--	HSD
VSD period time	t _V	510	525	650	HSD
VSD pulse width	t _{VPW}	1	--	20	HSD
VSD back porch	t _{VBP}	23	23	23	HSD
VSD front porch	t _{VFP}	7	22	147	HSD

3. QUALITY ASSURANCE SYSTEM

3.1 Quality Assurance Flow Chart

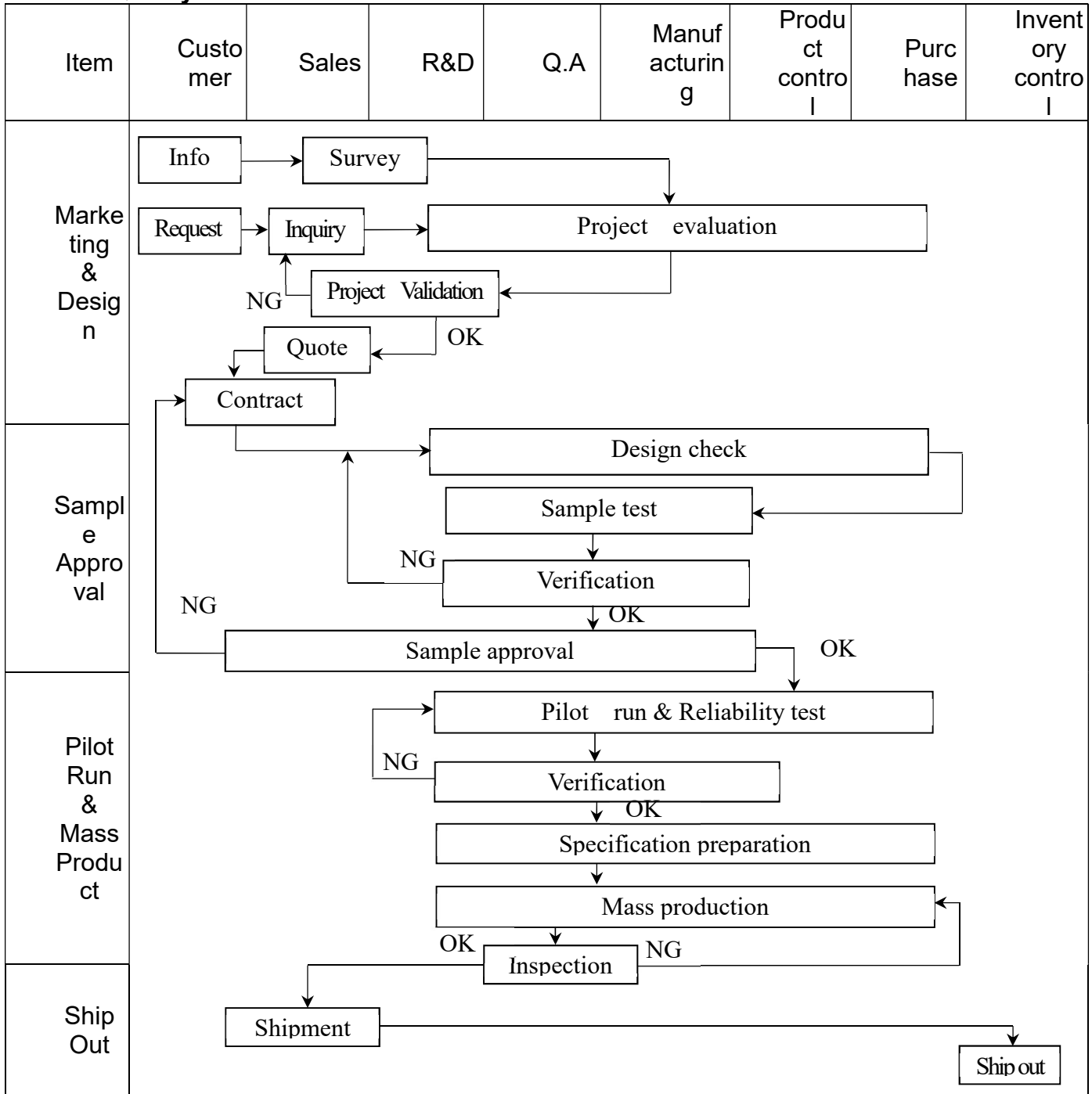

Item	Customer	Sales	R&D	Q.A	Manufacturing	Product control	Purchase	Inventory control
Sales Service	<pre> graph TD Info[Info] --> Claim[Claim] Claim --> Failure[Failure analysis] Failure --> Report[Analysis report] Failure --> Action[Corrective action] Action --> Tracking[Tracking] </pre>							
Q.A Activity	1. ISO 9001 Maintenance Activities 3. Equipment calibration 5. Standardization Management				2. Process improvement proposal 4. Education And Training Activities			

3.2 Inspection Specification

◆Scope : The document shall be applied to TFT-LCD Module for 3.5" ~15" (Ver.B01).

◆Inspection Standard : MIL-STD-105E Table Normal Inspection Single Sampling Level II .

◆Equipment : Gauge 、 MIL-STD 、 Powertip Tester 、 Sample

◆Defect Level : Major Defect AQL : 0.4 ; Minor Defect AQL : 1.5

◆OUT Going Defect Level : Sampling.

◆Standard of the product appearance test :

a. Manner of appearance test :

(1). The test best be under 20W×2 fluorescent light(about 300lux ~500lux)

， and distance of view must be at 30~40 cm.

(2). The test direction is base on about around 45° of vertical line.

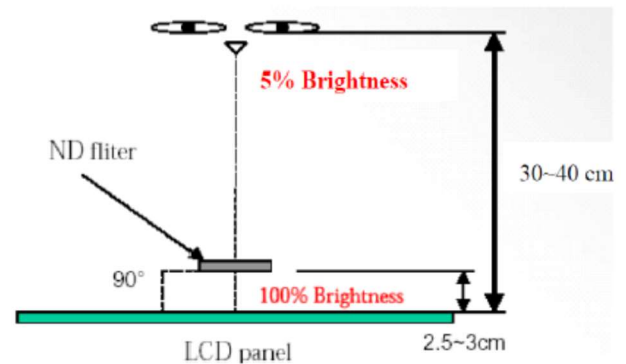
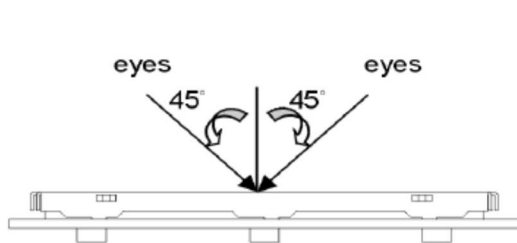

(3). Definition of area.

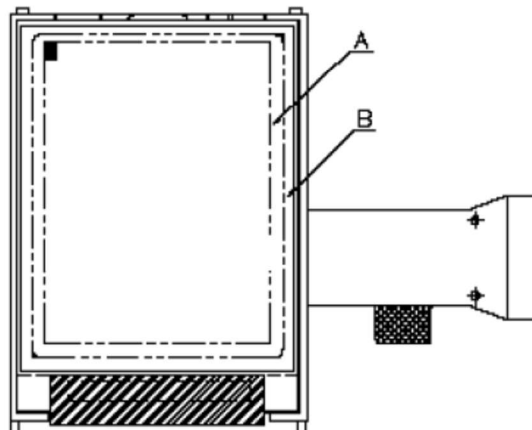

A area : viewing area

B area : Outside of viewing area

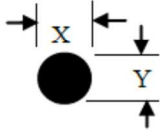
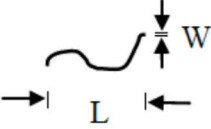

(4). Standard of inspection : (Unit : mm)

NO	Item	Criterion	Level												
01	Product condition	1. 1 The part number is inconsistent with work order of production.	Major												
		1. 2 Mixed product types.	Major												
		1. 3 Assembled in inverse direction.	Major												
02	Quantity	2. 1 The quantity is inconsistent with work order of production.	Major												
03	Outline dimension	3. 1 Product dimension and structure must conform to structure diagram.	Major												
04	Electrical Testing	4. 1 Missing line character and icon.	Major												
		4. 2 No function or no display.	Major												
		4. 3 Display malfunction.	Major												
		4. 4 LCD viewing angle defect.	Major												
		4. 5 Current consumption exceeds product specifications.	Major												
		4. 6 Mura can not be seen through 5% ND filter at 50% Gray screen , should be judged by the viewing angle of 90 degree.	Minor												
05	Dot defect (Bright dot 、 Dark dot) On -display	<table border="1" style="margin-left: auto; margin-right: auto;"> <thead> <tr> <th></th> <th>Item</th> <th>Acceptance (Q'ty)</th> </tr> </thead> <tbody> <tr> <td rowspan="4" style="text-align: center; vertical-align: middle;">Dot Defect</td> <td style="text-align: center;">Bright Dot</td> <td style="text-align: center;">≤ 4</td> </tr> <tr> <td style="text-align: center;">Dark Dot</td> <td style="text-align: center;">≤ 5</td> </tr> <tr> <td style="text-align: center;">Joint Dot</td> <td style="text-align: center;">≤ 3</td> </tr> <tr> <td style="text-align: center;">Total</td> <td style="text-align: center;">≤ 7</td> </tr> </tbody> </table>		Item	Acceptance (Q'ty)	Dot Defect	Bright Dot	≤ 4	Dark Dot	≤ 5	Joint Dot	≤ 3	Total	≤ 7	Minor
			Item	Acceptance (Q'ty)											
Dot Defect	Bright Dot	≤ 4													
	Dark Dot	≤ 5													
	Joint Dot	≤ 3													
	Total	≤ 7													
5. 1 Inspection pattern : full white , full black , Red , Green and blue screens. 5. 2 It is defined as dot defect if defect area $> 1/2$ dot. 5. 3 The distance between two dot defect ≥ 5 mm. 5. 4 Bright dot that can not be seen through 5% ND filter.															

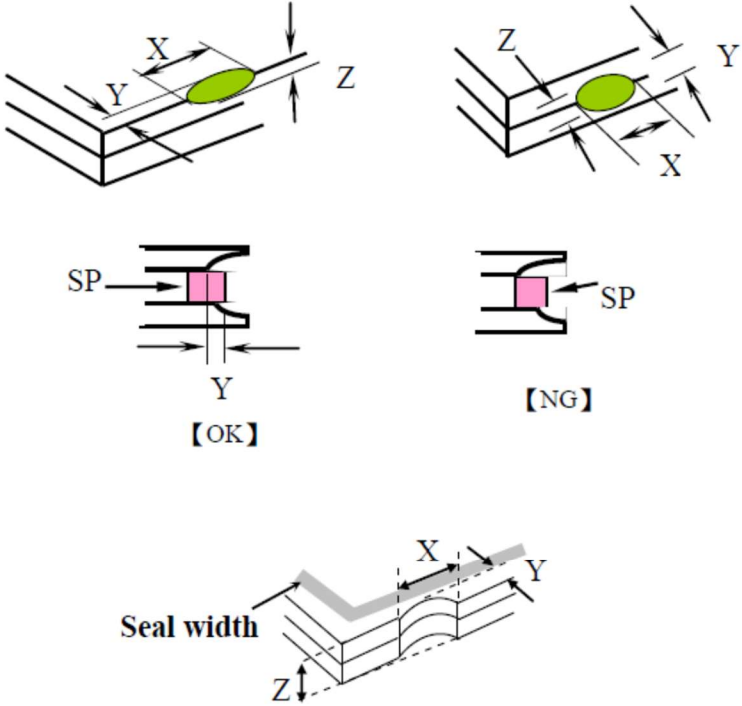
NO	Item	Criterion	Level																																																							
06	<p>Black or white dot、scratch、contamination</p> <p>Round type</p>  <p>$\Phi = (x + y) / 2$</p> <p>Line type</p> 	<p>6.1 Round type (Non-display or display) :</p> <table border="1" data-bbox="523 315 1278 589"> <thead> <tr> <th rowspan="2">Dimension (diameter : Φ)</th> <th colspan="2">Acceptance (Q'ty)</th> </tr> <tr> <th>A area</th> <th>B area</th> </tr> </thead> <tbody> <tr> <td>$\Phi \leq 0.25$</td> <td colspan="2">Ignore</td> </tr> <tr> <td>$0.25 < \Phi \leq 0.50$</td> <td>5</td> <td rowspan="3">Ignore</td> </tr> <tr> <td>$\Phi > 0.50$</td> <td>0</td> </tr> <tr> <td>Total</td> <td>5</td> </tr> </tbody> </table> <p>6.2 Line type(Non-display or display) :</p> <table border="1" data-bbox="448 701 1353 1227"> <thead> <tr> <th rowspan="2">module size</th> <th rowspan="2">Length (L)</th> <th rowspan="2">Width (W)</th> <th colspan="2">Acceptance (Q'ty)</th> </tr> <tr> <th>A area</th> <th>B area</th> </tr> </thead> <tbody> <tr> <td rowspan="5">3.5" to less 9"</td> <td>---</td> <td>$W \leq 0.03$</td> <td>Ignore</td> <td rowspan="5">Ignore</td> </tr> <tr> <td>$L \leq 10.0$</td> <td>$0.03 < W \leq 0.05$</td> <td>4</td> </tr> <tr> <td>$L \leq 5.0$</td> <td>$0.05 < W \leq 0.10$</td> <td>2</td> </tr> <tr> <td>---</td> <td>$W > 0.10$</td> <td>As round type</td> </tr> <tr> <td colspan="3">Total</td> <td>5</td> </tr> <tr> <td rowspan="4">9" to 15"</td> <td>---</td> <td>$W \leq 0.05$</td> <td>Ignore</td> <td rowspan="4">Ignore</td> </tr> <tr> <td>$L \leq 10.0$</td> <td>$0.05 < W \leq 0.10$</td> <td>5</td> </tr> <tr> <td>---</td> <td>$W > 0.10$</td> <td>As round type</td> </tr> <tr> <td colspan="3">Total</td> <td>5</td> </tr> </tbody> </table>	Dimension (diameter : Φ)	Acceptance (Q'ty)		A area	B area	$\Phi \leq 0.25$	Ignore		$0.25 < \Phi \leq 0.50$	5	Ignore	$\Phi > 0.50$	0	Total	5	module size	Length (L)	Width (W)	Acceptance (Q'ty)		A area	B area	3.5" to less 9"	---	$W \leq 0.03$	Ignore	Ignore	$L \leq 10.0$	$0.03 < W \leq 0.05$	4	$L \leq 5.0$	$0.05 < W \leq 0.10$	2	---	$W > 0.10$	As round type	Total			5	9" to 15"	---	$W \leq 0.05$	Ignore	Ignore	$L \leq 10.0$	$0.05 < W \leq 0.10$	5	---	$W > 0.10$	As round type	Total			5	Minor
Dimension (diameter : Φ)	Acceptance (Q'ty)																																																									
	A area	B area																																																								
$\Phi \leq 0.25$	Ignore																																																									
$0.25 < \Phi \leq 0.50$	5	Ignore																																																								
$\Phi > 0.50$	0																																																									
Total	5																																																									
module size	Length (L)	Width (W)	Acceptance (Q'ty)																																																							
			A area	B area																																																						
3.5" to less 9"	---	$W \leq 0.03$	Ignore	Ignore																																																						
	$L \leq 10.0$	$0.03 < W \leq 0.05$	4																																																							
	$L \leq 5.0$	$0.05 < W \leq 0.10$	2																																																							
	---	$W > 0.10$	As round type																																																							
	Total				5																																																					
9" to 15"	---	$W \leq 0.05$	Ignore	Ignore																																																						
	$L \leq 10.0$	$0.05 < W \leq 0.10$	5																																																							
	---	$W > 0.10$	As round type																																																							
	Total				5																																																					
07	Polarizer Bubble	<table border="1" data-bbox="491 1361 1313 1771"> <thead> <tr> <th rowspan="2">Dimension (diameter : Φ)</th> <th colspan="2">Acceptance (Q'ty)</th> </tr> <tr> <th>A area</th> <th>B area</th> </tr> </thead> <tbody> <tr> <td>$\Phi \leq 0.25$</td> <td colspan="2">Ignore</td> </tr> <tr> <td>$0.25 < \Phi \leq 0.50$</td> <td>4</td> <td rowspan="4">Ignore</td> </tr> <tr> <td>$0.50 < \Phi \leq 0.80$</td> <td>1</td> </tr> <tr> <td>$\Phi > 0.80$</td> <td>0</td> </tr> <tr> <td>Total</td> <td>5</td> </tr> </tbody> </table>	Dimension (diameter : Φ)	Acceptance (Q'ty)		A area	B area	$\Phi \leq 0.25$	Ignore		$0.25 < \Phi \leq 0.50$	4	Ignore	$0.50 < \Phi \leq 0.80$	1	$\Phi > 0.80$	0	Total	5	Minor																																						
Dimension (diameter : Φ)	Acceptance (Q'ty)																																																									
	A area	B area																																																								
$\Phi \leq 0.25$	Ignore																																																									
$0.25 < \Phi \leq 0.50$	4	Ignore																																																								
$0.50 < \Phi \leq 0.80$	1																																																									
$\Phi > 0.80$	0																																																									
Total	5																																																									

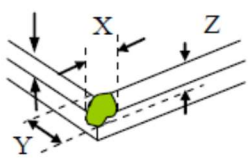
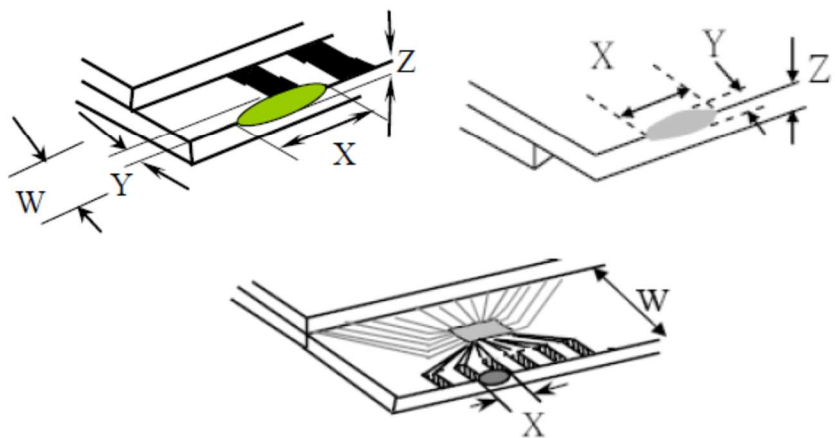
NO	Item	Criterion	Level						
08	The crack of glass	<p>Symbols :</p> <p>X : The length of crack Z : The thickness of crack t : The thickness of glass</p> <p>Y : The width of crack. W : terminal length a : LCD side length</p>	Minor						
		<p>8.1 General glass chip :</p> <p>8.1.1 Chip on panel surface and crack between panels:</p>  <table border="1" data-bbox="555 1438 1343 1720"> <thead> <tr> <th>X</th> <th>Y</th> <th>Z</th> </tr> </thead> <tbody> <tr> <td>$\leq a$</td> <td>Crack can't enter viewing area</td> <td>$\leq 1/2 t$</td> </tr> <tr> <td>$\leq a$</td> <td>Crack can't exceed the half of SP width.</td> <td>$1/2 t < Z \leq 2 t$</td> </tr> </tbody> </table>		X	Y	Z	$\leq a$	Crack can't enter viewing area	$\leq 1/2 t$
X	Y	Z							
$\leq a$	Crack can't enter viewing area	$\leq 1/2 t$							
$\leq a$	Crack can't exceed the half of SP width.	$1/2 t < Z \leq 2 t$							

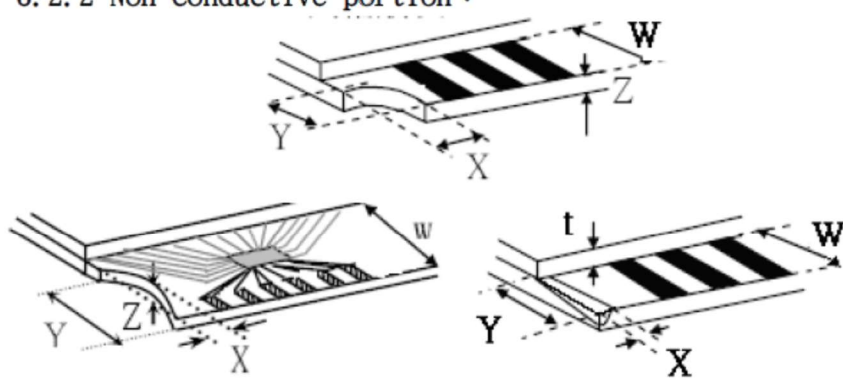
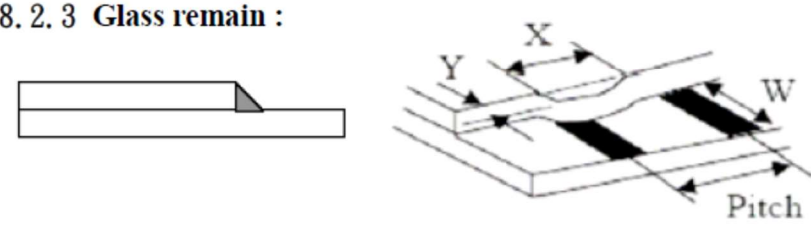
NO	Item	Criterion	Level												
08	The crack of glass	<p>Symbols :</p> <p>X : The length of crack Y : The width of crack. Z : The thickness of crack W : terminal length t : The thickness of glass a : LCD side length</p>	Minor												
		<p>8.1.2 Corner crack :</p>  <table border="1" data-bbox="518 660 1321 952"> <thead> <tr> <th>X</th> <th>Y</th> <th>Z</th> </tr> </thead> <tbody> <tr> <td>$\leq 1/5 a$</td> <td>Crack can't enter viewing area</td> <td>$Z \leq 1/2 t$</td> </tr> <tr> <td>$\leq 1/5 a$</td> <td>Crack can't exceed the half of SP width.</td> <td>$1/2 t < Z \leq 2 t$</td> </tr> </tbody> </table>		X	Y	Z	$\leq 1/5 a$	Crack can't enter viewing area	$Z \leq 1/2 t$	$\leq 1/5 a$	Crack can't exceed the half of SP width.	$1/2 t < Z \leq 2 t$			
X	Y	Z													
$\leq 1/5 a$	Crack can't enter viewing area	$Z \leq 1/2 t$													
$\leq 1/5 a$	Crack can't exceed the half of SP width.	$1/2 t < Z \leq 2 t$													
		<p>8.2 Protrusion over terminal :</p> <p>8.2.1 Chip on electrode pad :</p>  <table border="1" data-bbox="555 1579 1332 1747"> <thead> <tr> <th></th> <th>X</th> <th>Y</th> <th>Z</th> </tr> </thead> <tbody> <tr> <td>Front</td> <td>$\leq a$</td> <td>$\leq 1/2 W$</td> <td>$\leq t$</td> </tr> <tr> <td>Back</td> <td>$\leq a$</td> <td>$\leq W$</td> <td>$\leq 1/2 t$</td> </tr> </tbody> </table>		X	Y	Z	Front	$\leq a$	$\leq 1/2 W$	$\leq t$	Back	$\leq a$	$\leq W$	$\leq 1/2 t$	
	X	Y	Z												
Front	$\leq a$	$\leq 1/2 W$	$\leq t$												
Back	$\leq a$	$\leq W$	$\leq 1/2 t$												

NO	Item	Criterion	Level												
08	The crack of glass	<p>Symbols :</p> <p>X : The length of crack Y : The width of crack. Z : The thickness of crack W : terminal length t : The thickness of glass a : LCD side length</p> <p>8.2.2 Non-conductive portion :</p>  <table border="1" data-bbox="638 828 1244 963"> <thead> <tr> <th>X</th> <th>Y</th> <th>Z</th> </tr> </thead> <tbody> <tr> <td>$\leq 1/3 a$</td> <td>$\leq W$</td> <td>$\leq t$</td> </tr> </tbody> </table> <p>⊙ If the chipped area touches the ITO terminal, over 2/3 of the ITO must remain and be inspected according to electrode terminal specifications.</p> <p>8.2.3 Glass remain :</p>  <table border="1" data-bbox="558 1366 1228 1500"> <thead> <tr> <th>X</th> <th>Y</th> <th>Z</th> </tr> </thead> <tbody> <tr> <td>$\leq a$</td> <td>$\leq 1/3 W$</td> <td>$\leq t$</td> </tr> </tbody> </table> <p>8.2.4 Cracking</p>  <p style="text-align: center;">Not Allowed</p>	X	Y	Z	$\leq 1/3 a$	$\leq W$	$\leq t$	X	Y	Z	$\leq a$	$\leq 1/3 W$	$\leq t$	Minor
X	Y	Z													
$\leq 1/3 a$	$\leq W$	$\leq t$													
X	Y	Z													
$\leq a$	$\leq 1/3 W$	$\leq t$													

NO	Item	Criterion	Level
09	Backlight elements	9.1 Backlight can't work normally.	Major
		9.2 Backlight doesn't light or color is wrong.	Major
		9.3 Illumination source flickers when lit.	Major
10	General appearance	10.1 Pin type、quantity、dimension must match type in structure diagram.	Major
		10.2 No short circuits in components on PCB or FPC .	Major
		10.3 Parts on PCB or FPC must be the same as on the production characteristic chart .There should be no wrong parts , missing parts or excess parts.	Major
		10.4 Product packaging must the same as specified on packaging specification sheet.	Minor
		10.5 The folding and peeled off in polarizer are not acceptable.	Minor
		10.6 The PCB or FPC between B/L assembled distance(PCB or FPC) is ≤ 1.5 mm.	Minor

4. RELIABILITY TEST

4.1 Reliability Test Condition

NO.	TEST ITEM	TEST CONDITION												
1	High Temperature Storage Test	Keep in 80 ±5°C 240 hrs												
2	Low Temperature Storage Test	Keep in -30 ±5°C 240 hrs												
3	High Temperature / High Humidity Storage Test	Keep in 60 °C / 90% R.H duration for 240 hrs (Excluding the polarizer)												
4	Temperature Cycling Storage Test	$ \begin{array}{cccc} -30^{\circ}\text{C} & \rightarrow & +25^{\circ}\text{C} & \rightarrow & 80^{\circ}\text{C} & \rightarrow & +25^{\circ}\text{C} \\ (30\text{mins}) & & (5\text{mins}) & & (30\text{mins}) & & (5\text{mins}) \\ \leftarrow & & & & & & \rightarrow \\ & & & & & & 20 \text{ Cycle} \end{array} $												
5	ESD Test	Air Discharge: Apply 2 KV with 5 times Discharge for each polarity +/-	Contact Discharge: Apply 250 V with 5 times discharge for each polarity +/-											
		1. Temperature ambience : 15°C ~ 35°C 2. Humidity relative : 30% ~ 60% 3. Energy Storage Capacitance(Cs+Cd) : 150pF±10% 4. Discharge Resistance(Rd) : 330Ω±10% 5. Discharge, mode of operation : Single Discharge (time between successive discharges at least 1 sec) (Tolerance if the output voltage indication : ±5%)												
6	Vibration Test (Packaged)	1. Sine wave 10 ~ 55 Hz frequency (1 min/sweep) 2. The amplitude of vibration : 1.5 mm 3. Each direction (X、Y、Z) duration for 2 Hrs												
7	Drop Test (Packaged)	Drop	<table border="1"> <thead> <tr> <th>Packing Weight (Kg)</th> <th>Drop Height (cm)</th> </tr> </thead> <tbody> <tr> <td>0 ~ 45.4</td> <td>122</td> </tr> <tr> <td>45.4 ~ 90.8</td> <td>76</td> </tr> <tr> <td>90.8 ~ 454</td> <td>61</td> </tr> <tr> <td>Over 454</td> <td>46</td> </tr> </tbody> </table>		Packing Weight (Kg)	Drop Height (cm)	0 ~ 45.4	122	45.4 ~ 90.8	76	90.8 ~ 454	61	Over 454	46
			Packing Weight (Kg)	Drop Height (cm)										
			0 ~ 45.4	122										
			45.4 ~ 90.8	76										
			90.8 ~ 454	61										
Over 454	46													
Direction : ※1 corner / 3 edges / 6 sides each 1time														

◎Result Evaluation Criteria :

Under the display quality test conditions with normal operations with normal operation state. Do not change these conditions as such changes may affect practical display function.

(Normal operation state)

Temperature : +20~30°C

Humidity : 50~70%

Atmospheric pressure : 86~106Kpa

5. PRECAUTION RELATING PRODUCT HANDLING

5.1 SAFETY

- 5.1.1 If the LCD panel breaks , be careful not to get the liquid crystal to touch your skin.
- 5.1.2 If the liquid crystal touches your skin or clothes , please wash it off immediately by using soap and water.

5.2 HANDLING

- 5.2.1 Avoid any strong mechanical shock which can break the glass.
- 5.2.2 Avoid static electricity which can damage the CMOS LSI—When working with the module , be sure to ground your body and any electrical equipment you may be using.
- 5.2.3 Do not remove the panel or frame from the module.
- 5.2.4 The polarizing plate of the display is very fragile. So , please handle it very carefully ,do not touch , push or rub the exposed polarizing with anything harder than an HB pencil lead (glass , tweezers , etc.)
- 5.2.5 Do not wipe the polarizing plate with a dry cloth , as it may easily scratch the surface of plate.
- 5.2.6 Do not touch the display area with bare hands , this will stain the display area.
- 5.2.7 Do not use ketonics solvent & aromatic solvent. Use with a soft cloth soaked with a cleaning naphtha solvent.
- 5.2.8 To control temperature and time of soldering is $320\pm 10^{\circ}\text{C}$ and 3-5 sec.
- 5.2.9 To avoid liquid (include organic solvent) stained on LCM .

5.3 STORAGE

- 5.3.1 Store the panel or module in a dark place where the temperature is $25^{\circ}\text{C} \pm 5^{\circ}\text{C}$ and the humidity is below 65% RH.
- 5.3.2 Do not place the module near organics solvents or corrosive gases.
- 5.3.3 Do not crush , shake , or jolt the module.

5.4 TERMS OF WARRANTY

- 5.4.1 Applicable warrant period
The period is within thirteen months since the date of shipping out under normal using and storage conditions.
- 5.4.2 Unaccepted responsibility
This product has been manufactured to your company's specification as a part for use in your company's general electronic products. It is guaranteed to perform according to delivery specifications. For any other use apart from general electronic equipment , we cannot take responsibility if the product is used in nuclear power control equipment , aerospace equipment , fire and security systems or any other applications in which there is a direct risk to human life and where extremely high levels of reliability are required.

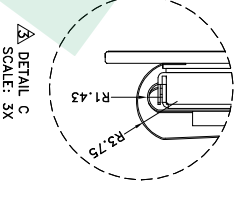
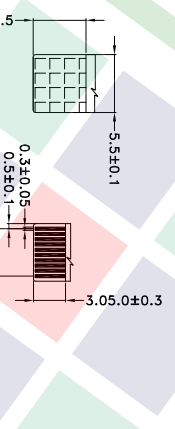
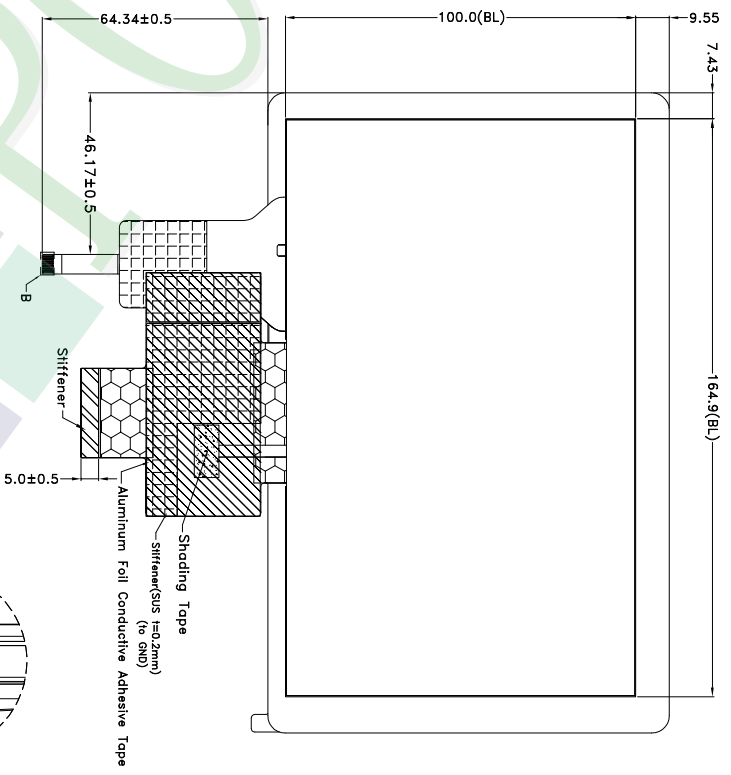
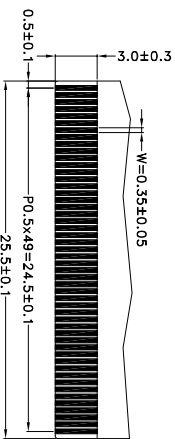
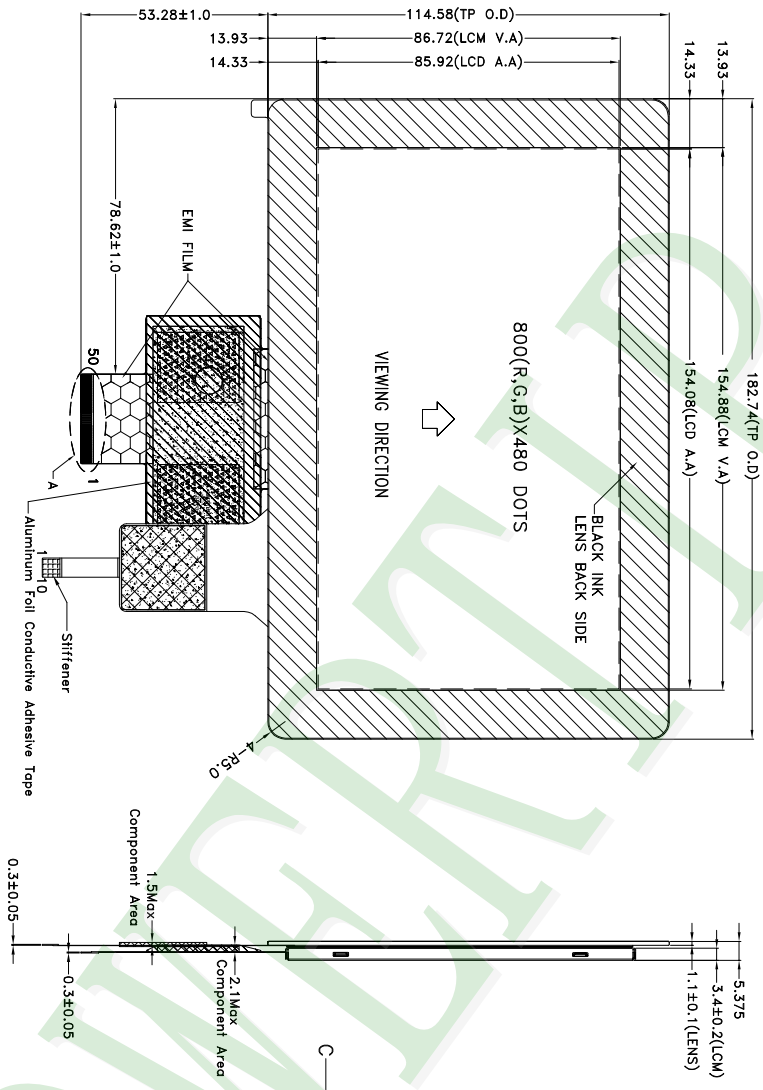

NOTES:
 1.LCD TYPE: TFT LCD
 2.LCD DISPLAY: POSITIVE/TRANSMISSIVE
 3.The tolerance unless classified ±0.3mm
 4.LCM suggested connector: "HIROSE FH12A-50S-0.5H OR EQUIVALENT"
 Δ5.1/P suggested connector: "HIROSE FH34SRJ-10S-0.5SH(50) OR EQUIVALENT"

007			
006			
005			
004			
003	Add the FPC bending radius & modify T/P suggested connector	Kevin	2020/05/20
002	MODIFY DRAWING	Kevin	2019/09/30
001	NEW DRAWING	Kevin	2019/09/25
REV	REV BY	REVISER	DATE

PART NO:	PH800480T013-IHC30
DRAWING NAME:	LMD-PH800480T013-IHC30
TITLE:	LCD MODULE DRAWING

Design	Kevin	Surface	7. Precision Level
Check	Stone	Material	1 ~ 4
Approve	Oliver	Thickness	4 ~ 16
		Quantity	16 ~ 63
			63 ~ 250
			250 ~ 1000

久正光電股份有限公司
 POWER TIP TECHNOLOGY CORPORATION



ALL TECHNOLOGIES. ALL COMPETENCIES. ONE SPECIALIST.



DATA MODUL AG
Landsberger Straße 322
DE-80687 Munich
Phone: +49-89-56017-0

DATA MODUL WEIKERSHEIM GMBH
Lindenstraße 8
DE-97990 Weikersheim
Phone: +49-7934-101-0



More information and worldwide locations can
be found at

www.data-modul.com